

National Testing Agency

Question Paper Name: Digital Design through Arduino
Subject Name: Digital Design through Arduino
Creation Date: 2019-03-30 13:12:42
Duration: 180
Total Marks: 100
Display Marks: Yes

Digital Design through Arduino

Group Number : 1
Group Id : 90958210
Group Maximum Duration : 0
Group Minimum Duration : 120
Revisit allowed for view? : No
Revisit allowed for edit? : No
Break time: 0
Group Marks: 100

Digital Design through Arduino

Section Id : 90958210
Section Number : 1
Section type : Online
Mandatory or Optional: Mandatory
Number of Questions: 100
Number of Questions to be attempted: 100
Section Marks: 100
Display Number Panel: Yes
Group All Questions: No

Sub-Section Number: 1
Sub-Section Id: 90958210
Question Shuffling Allowed : Yes

Question Number : 1 Question Type : MCQ Option Shuffling : No Display Question Number : Yes Single Line Question Option : No Option Orientation : Vertical

Correct Marks : 1 Wrong Marks : 0

Microcontroller Present in Arduino Uno

- ATmega382
- ATmega326
- ATmega328
- Atmega378

Options :

1. A
2. B
3. C
4. D

Question Number : 2 Question Type : MCQ Option Shuffling : No Display Question Number : Yes Single Line Question Option : No Option Orientation : Vertical

Correct Marks : 1 Wrong Marks : 0

Which of the following is the correct command to read digital data into Arduino

- a. `digitalRead(pin, Variable);`
- b. `digitalRead(Variable, pin);`
- c. `digitalread(pin);`
- d. None of the above

Options :

1. A
2. B
3. C
4. D

Question Number : 3 Question Type : MCQ Option Shuffling : No Display Question Number : Yes Single Line Question Option : No Option Orientation : Vertical

Correct Marks : 1 Wrong Marks : 0

Which of the following is correct

- a. `void setup()` is used to set the pin modes only
- b. `void setup()` function will run multiple times, after each power up or reset of the Arduino board.
- c. `void setup()` is used for initialize variable, pin modes, libraries.
- d. `void setup()` is used for initializing pin modes and serial monitor only

Options :

1. A
2. B
3. C
4. D

Question Number : 4 Question Type : MCQ Option Shuffling : No Display Question Number : Yes Single Line Question Option : No Option Orientation : Vertical

Correct Marks : 1 Wrong Marks : 0

ATmega microcontroller can execute how many instructions per second

- a. 1.6 billion instructions per second
- b. 16 million instructions per second
- c. 6 million instructions per second
- d. 1 billion instructions per second

Options :

- 1. A
- 2. B
- 3. C
- 4. D

Question Number : 5 Question Type : MCQ Option Shuffling : No Display Question Number : Yes Single Line Question Option : No Option Orientation : Vertical

Correct Marks : 1 Wrong Marks : 0

In 16X2 LCD Display, the meaning of 16X2 is

- a. It can print 16 lines and 2 characters
- b. It can print upto 32 characters
- c. It can print 16 characters and 2 lines
- d. Both b and C

Options :

- 1. A
- 2. B
- 3. C
- 4. D

Question Number : 6 Question Type : MCQ Option Shuffling : No Display Question Number : Yes Single Line Question Option : No Option Orientation : Vertical

Correct Marks : 1 Wrong Marks : 0

Display Decoder IC is

- a. 7744
- b. 7474
- c. 7484
- d. 7447

Options :

- 1. A
- 2. B
- 3. C
- 4. D

Question Number : 7 Question Type : MCQ Option Shuffling : No Display Question Number : Yes Single Line Question Option : No Option Orientation : Vertical

Correct Marks : 1 Wrong Marks : 0

D flip flop IC is

- a. 7744
- b. 7844
- c. 7474
- d. 7484

Options :

- 1. A
- 2. B
- 3. C
- 4. D

Question Number : 8 Question Type : MCQ Option Shuffling : No Display Question Number : Yes Single Line Question Option : No Option Orientation : Vertical

Correct Marks : 1 Wrong Marks : 0

Vectored interrupts interrupt the normal flow by:

- a. Taking the program flow to follow the vector table
- b. Taking the program flow to a subroutine function.
- c. Stopping the program flow
- d. None of these

Options :

- 1. A
- 2. B
- 3. C
- 4. D

Question Number : 9 Question Type : MCQ Option Shuffling : No Display Question Number : Yes Single Line Question Option : No Option Orientation : Vertical

Correct Marks : 1 Wrong Marks : 0

Which one of the following is direct addressing mode?

- a. `mov 64H, #40H`
- b. `mov 40H, a`
- c. `mov a, b`
- d. None of these

Options :

1. A
2. B
3. C
4. D

Question Number : 10 Question Type : MCQ Option Shuffling : No Display Question Number : Yes Single Line Question Option : No Option Orientation : Vertical

Correct Marks : 1 Wrong Marks : 0

How does a processor store the address of the next instruction while performing a subroutine?

- a. Pushes the address to stack memory
- b. Pops the address from the stack memory
- c. Stores it in a temporary variable
- d. None of these

Options :

1. A
2. B
3. C
4. D

Question Number : 11 Question Type : MCQ Option Shuffling : No Display Question Number : Yes Single Line Question Option : No Option Orientation : Vertical

Correct Marks : 1 Wrong Marks : 0

In assembly language, how is an ASCII characters stored as?

- a. Hexadecimal
- b. Binary
- c. Octal
- d. None of these

Options :

1. A
2. B
3. C
4. D

Question Number : 12 Question Type : MCQ Option Shuffling : No Display Question Number : Yes Single Line Question Option : No Option Orientation : Vertical

Correct Marks : 1 Wrong Marks : 0

Accumulator performs the following role in the processor architecture:

- a. Stores the variable on which the operation is currently being performed.
- b. Useful for shift operations.
- c. Affects the flags and hence can be used as a control for other purposes.
- d. All of these.

Options :

1. A
2. B
3. C
4. D

Question Number : 13 Question Type : MCQ Option Shuffling : No Display Question Number : Yes Single Line Question Option : No Option Orientation : Vertical

Correct Marks : 1 Wrong Marks : 0

The data size of a nibble is ___ bits.

- a. 4
- b. 8
- c. 32
- d. None of these

Options :

1. A
2. B
3. C
4. D

Question Number : 14 Question Type : MCQ Option Shuffling : No Display Question Number : Yes Single Line Question Option : No Option Orientation : Vertical

Correct Marks : 1 Wrong Marks : 0

The purpose of ORIGIN directive is to:

- a. Specifies the memory location from where the program will be stored.
- b. Specifies the data location which the program will use.
- c. Specifies the stack position
- d. None of these

Options :

1. A
2. B
3. C
4. D

Question Number : 15 Question Type : MCQ Option Shuffling : No Display Question Number : Yes Single Line Question Option : No Option Orientation : Vertical

Correct Marks : 1 Wrong Marks : 0

Overflow during a signed addition or subtraction happens when the two numbers have:

- a. Same signs
- b. Opposite signs
- c. Never happens in addition or subtraction
- d. When added or subtracted from zero

Options :

1. A
2. B
3. C
4. D

Question Number : 16 Question Type : MCQ Option Shuffling : No Display Question Number : Yes Single Line Question Option : No Option Orientation : Vertical

Correct Marks : 1 Wrong Marks : 0

If the peripheral address of the Timer register is 0x7f202000 and the base peripheral address is 0x7f000000, what will be the offset required?

- a. 0x00202000
- b. 0x7f200000
- c. 0x7f002000
- d. None of these

Options :

1. A
2. B
3. C
4. D

Question Number : 17 Question Type : MCQ Option Shuffling : No Display Question Number : Yes Single Line Question Option : No Option Orientation : Vertical

Correct Marks : 1 Wrong Marks : 0

Evaluate the output of the following:

```
ldi STACK, #40H
```

```
mvi a, #40H
```

```
push a
```

```
mvi b, #20H
```

```
push b
```

```
pop a
```

```
pop b
```

- a. a=40H, b=20H
- b. a=20H, b=40H
- c. a=40H, b=40H
- d. None of these

Options :

1. A
2. B
3. C
4. D

Question Number : 18 Question Type : MCQ Option Shuffling : No Display Question Number : Yes Single Line Question Option : No Option Orientation : Vertical

Correct Marks : 1 Wrong Marks : 0

What would be the final value in 'a' after performing the following operations?

```
mvi a, #40H
```

```
lsl a
```

- a. 20H
- b. 80H
- c. 10H
- d. None of these

Options :

- 1. A
- 2. B
- 3. C
- 4. D

Question Number : 19 Question Type : MCQ Option Shuffling : No Display Question Number : Yes Single Line Question Option : No Option Orientation : Vertical

Correct Marks : 1 Wrong Marks : 0

What would be decimal equivalent of the following input $Y = 00001000 \ll 2$?

- a. 16
- b. 32
- c. 8
- d. None of these

Options :

- 1. A
- 2. B
- 3. C
- 4. D

Question Number : 20 Question Type : MCQ Option Shuffling : No Display Question Number : Yes Single Line Question Option : No Option Orientation : Vertical

Correct Marks : 1 Wrong Marks : 0

If the input is $A=01111010$ and the output is $Y=01010010$, what masking operation can be performed?

- a. $Y=A$ and 11010011
- b. $=A$ and 11110000
- c. $Y=A$ or 00110001
- d. $Y=A$ exor 11111100

Options :

- 1. A
- 2. B
- 3. C
- 4. D

Question Number : 21 Question Type : MCQ Option Shuffling : No Display Question Number : Yes Single Line Question Option : No Option Orientation : Vertical

Correct Marks : 1 Wrong Marks : 0

How many address lines would be required to decipher 65536 memory locations?

- a. 16
- b. 15
- c. 32
- d. 31

Options :

- 1. A
- 2. B
- 3. C
- 4. D

Question Number : 22 Question Type : MCQ Option Shuffling : No Display Question Number : Yes Single Line Question Option : No Option Orientation : Vertical

Correct Marks : 1 Wrong Marks : 0

To run a program 10 times what would be the parameter for the counter variable?

- a. 10H
- b. 05H
- c. 0AH
- d. None of these

Options :

- 1. A
- 2. B

3. C

4. D

Question Number : 23 Question Type : MCQ Option Shuffling : No Display Question Number : Yes Single Line Question Option : No Option Orientation : Vertical

Correct Marks : 1 Wrong Marks : 0

If the opcode in the following instruction takes 2 bytes to store in the memory, then the complete instruction will take how much memory bytes?

RET #1600H

a. 4

b. 2

c. 16

d. 8

Options :

1. A

2. B

3. C

4. D

Question Number : 24 Question Type : MCQ Option Shuffling : No Display Question Number : Yes Single Line Question Option : No Option Orientation : Vertical

Correct Marks : 1 Wrong Marks : 0

If an 8-bit instruction takes 4 clock cycles for complete operation, how many clock cycles will it take for 4 such instructions?

a. 16

b. 32

c. 4

d. 8

Options :

1. A

2. B

3. C

4. D

Question Number : 25 Question Type : MCQ Option Shuffling : No Display Question Number : Yes Single Line Question Option : No Option Orientation : Vertical

Correct Marks : 1 Wrong Marks : 0

Output of following will be

EXOR #11001111B, #00001111B

- a. 11000000
- b. 00001111
- c. 11111111
- d. None of these

Options :

- 1. A
- 2. B
- 3. C
- 4. D

Question Number : 26 Question Type : MCQ Option Shuffling : No Display Question Number : Yes Single Line Question Option : No Option Orientation : Vertical

Correct Marks : 1 Wrong Marks : 0

What is the total number of pins in atmega328p IC ?

- a. 14
- b. 16
- c. 28
- d. 20

Options :

- 1. A
- 2. B
- 3. C
- 4. D

Question Number : 27 Question Type : MCQ Option Shuffling : No Display Question Number : Yes Single Line Question Option : No Option Orientation : Vertical

Correct Marks : 1 Wrong Marks : 0

To which port does the in built led pin is connected in atmega 328p.?

- a. PORT A
- b. PORT B
- c. PORT C
- d. PORT D

Options :

- 1. A
- 2. B

- 3. C
- 4. D

Question Number : 28 Question Type : MCQ Option Shuffling : No Display Question Number : Yes Single Line Question Option : No Option Orientation : Vertical

Correct Marks : 1 Wrong Marks : 0

What is the name of direction register in atmega 328p

- a. DRGT
- b. DDRx
- c. DDRT
- d. Data

Options :

- 1. A
- 2. B
- 3. C
- 4. D

Question Number : 29 Question Type : MCQ Option Shuffling : No Display Question Number : Yes Single Line Question Option : No Option Orientation : Vertical

Correct Marks : 1 Wrong Marks : 0

How many registers does each port have ?

- a. 1
- b. 2
- c. 3
- d. 4

Options :

- 1. A
- 2. B
- 3. C
- 4. D

Question Number : 30 Question Type : MCQ Option Shuffling : No Display Question Number : Yes Single Line Question Option : No Option Orientation : Vertical

Correct Marks : 1 Wrong Marks : 0

What does the direction 1 symbolises ?

- a. INPUT
- b. OUTPUT
- c. Both
- d. None

Options :

- 1. A
- 2. B
- 3. C
- 4. D

Question Number : 31 Question Type : MCQ Option Shuffling : No Display Question Number : Yes Single Line Question Option : No Option Orientation : Vertical

Correct Marks : 1 Wrong Marks : 0

What does 0 symbolises on data direction register.?

- a. INPUT
- b. OUTPUT
- c. Both
- d. None

Options :

- 1. A
- 2. B
- 3. C
- 4. D

Question Number : 32 Question Type : MCQ Option Shuffling : No Display Question Number : Yes Single Line Question Option : No Option Orientation : Vertical

Correct Marks : 1 Wrong Marks : 0

How to declare 1st pin in port B as input pin.?

- a. `DDRB 0b00000010`
- b. `DDRB 0b11111101`
- c. `DDRD 0b00000010`
- d. `DDRC 0b11111101`

Options :

- 1. A
- 2. B
- 3. C

4. D

Question Number : 33 Question Type : MCQ Option Shuffling : No Display Question Number : Yes Single Line Question Option : No Option Orientation : Vertical

Correct Marks : 1 Wrong Marks : 0

How to declare 1,4,7th pin port D as input pin.?

- a. DDRD 0b01110110
- b. DDRD 0b10001001
- c. DDRC 0b10011101
- d. DDRD 0b01101101

Options :

- 1. A
- 2. B
- 3. C
- 4. D

Question Number : 34 Question Type : MCQ Option Shuffling : No Display Question Number : Yes Single Line Question Option : No Option Orientation : Vertical

Correct Marks : 1 Wrong Marks : 0

Name the IC present in arduino board?

- a. Atmega 320
- b. Atmega 328
- c. Atmega 322
- d. Atmega 330

Options :

- 1. A
- 2. B
- 3. C
- 4. D

Question Number : 35 Question Type : MCQ Option Shuffling : No Display Question Number : Yes Single Line Question Option : No Option Orientation : Vertical

Correct Marks : 1 Wrong Marks : 0

Into how many port does the pins of atmega328p are divided ?

- a. 1
- b. 2
- c. 3
- d. 4

Options :

1. A
2. B
3. C
4. D

Question Number : 36 Question Type : MCQ Option Shuffling : No Display Question Number : Yes Single Line Question Option : No Option Orientation : Vertical

Correct Marks : 1 Wrong Marks : 0

Which port in atmega328p is configured as analog pins?

- a. PORT A
- b. PORT B
- c. PORT C
- d. PORT D

Options :

1. A
2. B
3. C
4. D

Question Number : 37 Question Type : MCQ Option Shuffling : No Display Question Number : Yes Single Line Question Option : No Option Orientation : Vertical

Correct Marks : 1 Wrong Marks : 0

Assume that an LED is placed on the 7th pin of port D and is declared as output pin. What is the value of PORTD register value to turn on the LED.

- a. 0b00000000
- b. 0b10000000
- c. 0b01000000
- d. 0b11111111

Options :

1. A
2. B
3. C
4. D

Question Number : 38 Question Type : MCQ Option Shuffling : No Display Question Number : Yes Single Line Question Option : No Option Orientation : Vertical

Correct Marks : 1 Wrong Marks : 0

Name the header file for the Embedded C programming ?

- a. Avr.h
- b. avr/io.h
- c. Io.h
- d. Avrio.h

Options :

- 1. A
- 2. B
- 3. C
- 4. D

Question Number : 39 Question Type : MCQ Option Shuffling : No Display Question Number : Yes Single Line Question Option : No Option Orientation : Vertical

Correct Marks : 1 Wrong Marks : 0

Name the header file for using delay in the Embedded C programming ?

- a. avr/delay.h
- b. avrdelay.h
- c. Delay.h
- d. avr/delay

Options :

- 1. A
- 2. B
- 3. C
- 4. D

Question Number : 40 Question Type : MCQ Option Shuffling : No Display Question Number : Yes Single Line Question Option : No Option Orientation : Vertical

Correct Marks : 1 Wrong Marks : 0

How to provide a delay in embedded C ?

- a. delay_ms(1000);
- b. _delayms(1000);
- c. _delay(1000);
- d. _delay_ms(1000);

Options :

- 1. A
- 2. B
- 3. C
- 4. D

Question Number : 41 Question Type : MCQ Option Shuffling : No Display Question Number : Yes Single Line Question Option : No Option Orientation : Vertical

Correct Marks : 1 Wrong Marks : 0

How to provide a delay of 7 seconds in embedded C ?

- a. `_delay_ms(7000);`
- b. `_delayms(7);`
- c. `_delay(7000);`
- d. `delay_ms(7);`

Options :

- 1. A
- 2. B
- 3. C
- 4. D

Question Number : 42 Question Type : MCQ Option Shuffling : No Display Question Number : Yes Single Line Question Option : No Option Orientation : Vertical

Correct Marks : 1 Wrong Marks : 0

What is the extension for embedded c programming?

- a. `.c`
- b. `.embdd c`
- c. `.cpp`
- d. `.embc`

Options :

- 1. A
- 2. B
- 3. C
- 4. D

Question Number : 43 Question Type : MCQ Option Shuffling : No Display Question Number : Yes Single Line Question Option : No Option Orientation : Vertical

Correct Marks : 1 Wrong Marks : 0

Which of the following is a sensor.?

- a. PIR
- b. Relay
- c. Servo motor
- d. DC motor

Options :

1. A
2. B
3. C
4. D

Question Number : 44 Question Type : MCQ Option Shuffling : No Display Question Number : Yes Single Line Question Option : No Option Orientation : Vertical

Correct Marks : 1 Wrong Marks : 0

Which of the following is a actuator.?

- a. PIR
- b. LDR
- c. Relay
- d. HC-SR04

Options :

1. A
2. B
3. C
4. D

Question Number : 45 Question Type : MCQ Option Shuffling : No Display Question Number : Yes Single Line Question Option : No Option Orientation : Vertical

Correct Marks : 1 Wrong Marks : 0

What is the phenomenon on which LDR works

- a. Photo-resistivity
- b. Photosensitivity
- c. Photo-conductivity
- d. Photoelasticity

Options :

1. A
2. B
3. C
4. D

Question Number : 46 Question Type : MCQ Option Shuffling : No Display Question Number : Yes Single Line Question Option : No Option Orientation : Vertical

Correct Marks : 1 Wrong Marks : 0

What is the phenomenon on which HC-SR04 works ?

- a. Sonar
- b. Radar
- c. Photo-Conductivity
- d. Photo Elasticity

Options :

- 1. A
- 2. B
- 3. C
- 4. D

Question Number : 47 Question Type : MCQ Option Shuffling : No Display Question Number : Yes Single Line Question Option : No Option Orientation : Vertical

Correct Marks : 1 Wrong Marks : 0

Why are the two potentiometers provided in PIR sensor ?

- a. To adjust brightness and delay
- b. To adjust delay and range
- c. To adjust delay and timing
- d. To adjust delay and distance

Options :

- 1. A
- 2. B
- 3. C
- 4. D

Question Number : 48 Question Type : MCQ Option Shuffling : No Display Question Number : Yes Single Line Question Option : No Option Orientation : Vertical

Correct Marks : 1 Wrong Marks : 0

What are the two types of switches in relay?

- a. Normally open
- b. Normally closed
- c. Both a and b
- d. Switch

Options :

- 1. A
- 2. B
- 3. C

4. D

Question Number : 49 Question Type : MCQ Option Shuffling : No Display Question Number : Yes Single Line Question Option : No Option Orientation : Vertical

Correct Marks : 1 Wrong Marks : 0

Servo motor is _____ actuator

- a. Rotary actuator
- b. Linear actuator
- c. Bilinear actuator
- d. Mechanical actuator

Options :

- 1. A
- 2. B
- 3. C
- 4. D

Question Number : 50 Question Type : MCQ Option Shuffling : No Display Question Number : Yes Single Line Question Option : No Option Orientation : Vertical

Correct Marks : 1 Wrong Marks : 0

Which of the following statements is correct ?

- a. actuators and sensors are forms of transducers
- b. sensors are forms of transducers
- c. Actuators are forms of transducers
- d. None of these

Options :

- 1. A
- 2. B
- 3. C
- 4. D

Question Number : 51 Question Type : MCQ Option Shuffling : No Display Question Number : Yes Single Line Question Option : No Option Orientation : Vertical

Correct Marks : 1 Wrong Marks : 0

LDR is abbreviated for?

- a. Light Diode Resistor
- b. Linear Dependent Resistor
- c. Light Dependent Resistor
- d. Lense Dependent Resistance

Options :

1. A
2. B
3. C
4. D

Question Number : 52 Question Type : MCQ Option Shuffling : No Display Question Number : Yes Single Line Question Option : No Option Orientation : Vertical

Correct Marks : 1 Wrong Marks : 0

PIR stands for

- a. Passive Infrared
- b. Positive Infrared
- c. Position infrared
- d. Point infrared

Options :

1. A
2. B
3. C
4. D

Question Number : 53 Question Type : MCQ Option Shuffling : No Display Question Number : Yes Single Line Question Option : No Option Orientation : Vertical

Correct Marks : 1 Wrong Marks : 0

What is the extension of an arduino file

- a. .c
- b. .cpp
- c. .py
- d. .ino

Options :

1. A
2. B
3. C
4. D

Question Number : 54 Question Type : MCQ Option Shuffling : No Display Question Number : Yes Single Line Question Option : No Option Orientation : Vertical

Correct Marks : 1 Wrong Marks : 0

Which of the following statement is true ?

- a. We cannot control the speed of servo motor
- b. We can control the speed of servo motor
- c. Both a and b
- d. None of these

Options :

- 1. A
- 2. B
- 3. C
- 4. D

Question Number : 55 Question Type : MCQ Option Shuffling : No Display Question Number : Yes Single Line Question Option : No Option Orientation : Vertical

Correct Marks : 1 Wrong Marks : 0

Realy is _____ switch

- a. Electro-mechanical
- b. Electro-magnetic
- c. Magnetic
- d. Electrical

Options :

- 1. A
- 2. B
- 3. C
- 4. D

Question Number : 56 Question Type : MCQ Option Shuffling : No Display Question Number : Yes Single Line Question Option : No Option Orientation : Vertical

Correct Marks : 1 Wrong Marks : 0

Ultrasonic sensor has _____

- a. Transmitter
- b. Receiver
- c. Both a and b
- d. None of the above.

Options :

- 1. A
- 2. B
- 3. C
- 4. D

Question Number : 57 Question Type : MCQ Option Shuffling : No Display Question Number : Yes Single Line Question Option : No Option Orientation : Vertical

Correct Marks : 1 Wrong Marks : 0

Which are the two pins HC-SR04

- a. Trig
- b. Echo
- c. Both a and b
- d. None

Options :

- 1. A
- 2. B
- 3. C
- 4. D

Question Number : 58 Question Type : MCQ Option Shuffling : No Display Question Number : Yes Single Line Question Option : No Option Orientation : Vertical

Correct Marks : 1 Wrong Marks : 0

How many pins are present in PIR sensor ?

- a. 1
- b. 2
- c. 3
- d. 4

Options :

- 1. A
- 2. B
- 3. C
- 4. D

Question Number : 59 Question Type : MCQ Option Shuffling : No Display Question Number : Yes Single Line Question Option : No Option Orientation : Vertical

Correct Marks : 1 Wrong Marks : 0

Which of the following is a an actuator. ?

- a. Rack and pinion
- b. Thermometer
- c. PIR
- d. None of the above

Options :

- 1. A

2. B
3. C
4. D

Question Number : 60 Question Type : MCQ Option Shuffling : No Display Question Number : Yes Single Line Question Option : No Option Orientation : Vertical

Correct Marks : 1 Wrong Marks : 0

What is the baud rate for the serial communication in arduino ?

- a. 9200
- b. 6558
- c. 9600
- d. 9700

Options :

1. A
2. B
3. C
4. D

Question Number : 61 Question Type : MCQ Option Shuffling : No Display Question Number : Yes Single Line Question Option : No Option Orientation : Vertical

Correct Marks : 1 Wrong Marks : 0

What is the command to print "Hello" in arduino serial monitor ?

- a. `serial.print("Hello");`
- b. `serial.println("Hello");`
- c. `Serial.print("Hello");`
- d. `serial.print>Hello);`

Options :

1. A
2. B
3. C
4. D

Question Number : 62 Question Type : MCQ Option Shuffling : No Display Question Number : Yes Single Line Question Option : No Option Orientation : Vertical

Correct Marks : 1 Wrong Marks : 0

Port B is _____ port

- a. INPUT port
- b. OUTPUT port
- c. Analog port
- d. DIgital port

Options :

- 1. A
- 2. B
- 3. C
- 4. D

Question Number : 63 Question Type : MCQ Option Shuffling : No Display Question Number : Yes Single Line Question Option : No Option Orientation : Vertical

Correct Marks : 1 Wrong Marks : 0

Name the pin in arduino board which is connected to inbuilt LED?

- a. D13
- b. D5
- c. D9
- d. D0

Options :

- 1. A
- 2. B
- 3. C
- 4. D

Question Number : 64 Question Type : MCQ Option Shuffling : No Display Question Number : Yes Single Line Question Option : No Option Orientation : Vertical

Correct Marks : 1 Wrong Marks : 0

Please find the equivalent boolean expression in the Arduino Code for the boolean expression $XY + XZ' + YZ$

- a. $(X \& \& Y) \parallel (Y \& \& Z)$
- b. $(X \& \& !Z) \parallel (Y \& \& X)$
- c. $(Y \& \& Z) \parallel (X \& \& !Z)$
- d. $(X \& \& Y) \parallel (X \& \& !Z) \parallel Z$

Options :

- 1. A
- 2. B
- 3. C

4. D

Question Number : 65 Question Type : MCQ Option Shuffling : No Display Question Number : Yes Single Line Question Option : No Option Orientation : Vertical

Correct Marks : 1 Wrong Marks : 0

For 3 input logic circuit shown below, the output Z can be expressed as

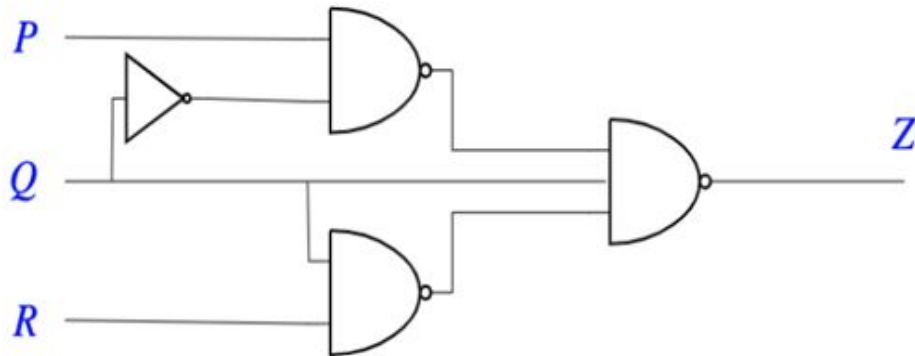

- a. $Q \parallel !R$
- b. $(P \& \& !Q) \parallel R$
- c. $!Q \parallel R$
- d. $P \parallel !Q \parallel R$

Options :

- 1. A
- 2. B
- 3. C
- 4. D

Question Number : 66 Question Type : MCQ Option Shuffling : No Display Question Number : Yes Single Line Question Option : No Option Orientation : Vertical

Correct Marks : 1 Wrong Marks : 0

The output expression for the Karnaugh map shown below is

		BC			
		00	01	11	10
A	0	1	0	0	1
	1	1	1	1	1

- a. $A \parallel !B$
- b. $A \parallel !C$
- c. $!A \parallel !C$
- d. $!A \parallel C$

Options :

- 1. A
- 2. B
- 3. C
- 4. D

Question Number : 67 Question Type : MCQ Option Shuffling : No Display Question Number : Yes Single Line Question Option : No Option Orientation : Vertical

Correct Marks : 1 Wrong Marks : 0

In the following Circuit, X is given by

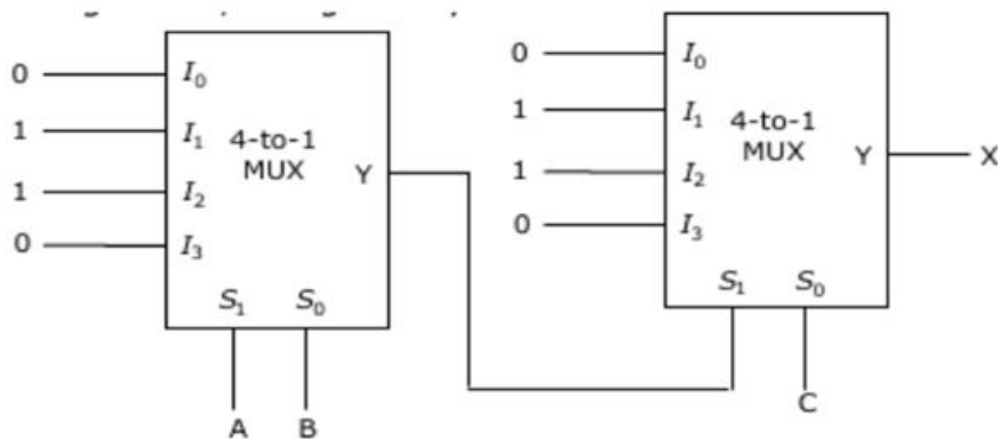

- a. $X = (A \& \& !B) \parallel (!A \& \& B \& \& !C) \parallel (!A \& \& !B \& \& C) \parallel (A \& \& B \& \& C)$
- b. $X = (A \& \& B) \parallel (B \& \& C) \parallel (A \& \& C)$
- c. Both a and b
- d. None of the above

Options :

- 1. A

2. B
3. C
4. D

Question Number : 68 Question Type : MCQ Option Shuffling : No Display Question Number : Yes Single Line Question Option : No Option Orientation : Vertical

Correct Marks : 1 Wrong Marks : 0

Logic equation in C language for the following circuit is

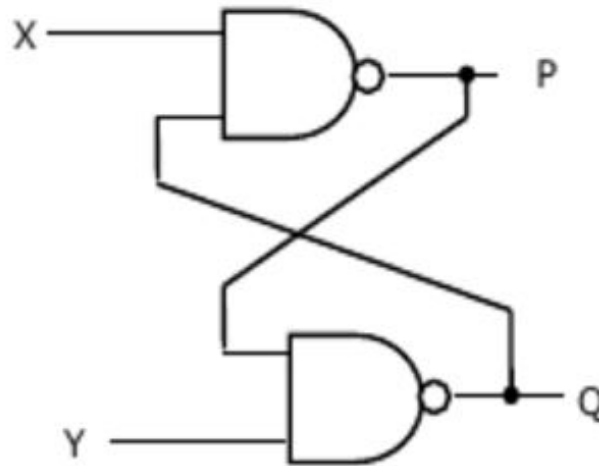

- a. $P = !(QX) + !(PY);$
- b. $P = !(QX); Q = !(PY);$
- c. $P = !(Q\&\&X), Q = !(P\&Y)$
- d. $P = !(Q\&\&X); Q = !(P\&\&Y);$

Options :

1. A
2. B
3. C
4. D

Question Number : 69 Question Type : MCQ Option Shuffling : No Display Question Number : Yes Single Line Question Option : No Option Orientation : Vertical

Correct Marks : 1 Wrong Marks : 0

What is need to use arduino for digital design ?

- a. It is easy to program compared to FPGA boards.
- b. Digital circuit designed on arduino is more efficient then compared to FPGA.
- c. As arduino is cheaper compared to FPGA and get a flavor of verilog programming.
- d. None of the above

Options :

1. A

2. B
3. C
4. D

Question Number : 70 Question Type : MCQ Option Shuffling : No Display Question Number : Yes Single Line Question Option : No Option Orientation : Vertical

Correct Marks : 1 Wrong Marks : 0

What does LOW sends on the Arduino pin?

- a. 1V
- b. 0V
- c. 0.7V
- d. None

Options :

1. A
2. B
3. C
4. D

Question Number : 71 Question Type : MCQ Option Shuffling : No Display Question Number : Yes Single Line Question Option : No Option Orientation : Vertical

Correct Marks : 1 Wrong Marks : 0

How to declare 9th pin as output pin in arduino ?

- a. `pinmode(9,OUTPUT);`
- b. `pinMode(9,OUTPUT);`
- c. `pin.mode(9,OUTPUT);`
- d. `pin.Mode(9,OUTPUT);`

Options :

1. A
2. B
3. C
4. D

Question Number : 72 Question Type : MCQ Option Shuffling : No Display Question Number : Yes Single Line Question Option : No Option Orientation : Vertical

Correct Marks : 1 Wrong Marks : 0

What does PWM stand for?

- a. Pulse Wear Modulating
- b. Pulse Width Modulating
- c. Pulse Width Modulation
- d. Pulse Wide Memory

Options :

- 1. A
- 2. B
- 3. C
- 4. D

Question Number : 73 Question Type : MCQ Option Shuffling : No Display Question Number : Yes Single Line Question Option : No Option Orientation : Vertical

Correct Marks : 1 Wrong Marks : 0

How are the pulses from the signal line converted into voltage inside a servo motor?

- a. Due to charging and discharging of internal capacitors
- b. Due to digital to analog converter
- c. Due to comparator
- d. Due to operational amplifier

Options :

- 1. A
- 2. B
- 3. C
- 4. D

Question Number : 74 Question Type : MCQ Option Shuffling : No Display Question Number : Yes Single Line Question Option : No Option Orientation : Vertical

Correct Marks : 1 Wrong Marks : 0

What provides the feedback signal to the motor in servo mechanism?

- a. An operational amplifier(comparator)
- b. A transistor
- c. A diode
- d. A capacitor

Options :

- 1. A
- 2. B
- 3. C
- 4. D

Question Number : 75 Question Type : MCQ Option Shuffling : No Display Question Number : Yes Single Line Question Option : No Option Orientation : Vertical

Correct Marks : 1 Wrong Marks : 0

What acts like an position sensor in the servo mechanism?

- a. Voltage converter
- b. Gearset
- c. Potentiometer
- d. DAC

Options :

- 1. A
- 2. B
- 3. C
- 4. D

Question Number : 76 Question Type : MCQ Option Shuffling : No Display Question Number : Yes Single Line Question Option : No Option Orientation : Vertical

Correct Marks : 1 Wrong Marks : 0

How many millisecond pulse has to be sent to the servo motor for it to turn to 75 degrees?

- a. 1.4
- b. 1.6
- c. 2
- d. 1

Options :

- 1. A
- 2. B
- 3. C
- 4. D

Question Number : 77 Question Type : MCQ Option Shuffling : No Display Question Number : Yes Single Line Question Option : No Option Orientation : Vertical

Correct Marks : 1 Wrong Marks : 0

What is duty cycle ?

- a. The percentage of time the pulse is high to the period.
- b. The percentage of time the triangle wave is high to the square wave.
- c. It is the proportion to the no of on times in the successive time intervals.
- d. It is a number between 0 and 255

Options :

- 1. A

2. B
3. C
4. D

Question Number : 78 Question Type : MCQ Option Shuffling : No Display Question Number : Yes Single Line Question Option : No Option Orientation : Vertical

Correct Marks : 1 Wrong Marks : 0

What is the duty cycle of a pure square wave?

- a. 50%
- b. 35%
- c. 45%
- d. 10%

Options :

1. A
2. B
3. C
4. D

Question Number : 79 Question Type : MCQ Option Shuffling : No Display Question Number : Yes Single Line Question Option : No Option Orientation : Vertical

Correct Marks : 1 Wrong Marks : 0

What predefined function is used to modulate the pulse widths ?

- a. analogWrite()
- b. digitalWrite()
- c. map()
- d. tone()

Options :

1. A
2. B
3. C
4. D

Question Number : 80 Question Type : MCQ Option Shuffling : No Display Question Number : Yes Single Line Question Option : No Option Orientation : Vertical

Correct Marks : 1 Wrong Marks : 0

How many parameters does the function analogWrite take?

- a. 5
- b. 6
- c. 1
- d. 2

Options :

- 1. A
- 2. B
- 3. C
- 4. D

Question Number : 81 Question Type : MCQ Option Shuffling : No Display Question Number : Yes Single Line Question Option : No Option Orientation : Vertical

Correct Marks : 1 Wrong Marks : 0

What is the resolution of the arduino pwm enabled pins to produce pulses?

- a. 10 bit
- b. 5 bit
- c. 8 bit
- d. 12 bit

Options :

- 1. A
- 2. B
- 3. C
- 4. D

Question Number : 82 Question Type : MCQ Option Shuffling : No Display Question Number : Yes Single Line Question Option : No Option Orientation : Vertical

Correct Marks : 1 Wrong Marks : 0

What are the range of values does the second parameter of analogWrite takes?

- a. 0-255
- b. 0 - 1023
- c. 1-256
- d. 0-511

Options :

- 1. A
- 2. B
- 3. C
- 4. D

Question Number : 83 Question Type : MCQ Option Shuffling : No Display Question Number : Yes Single Line Question Option : No Option Orientation : Vertical

Correct Marks : 1 Wrong Marks : 0

Writing 127 to arduino using analogWrite outputs a pulse of what duty cycle?

- a. 50%
- b. 76%
- c. 25%
- d. 10%

Options :

- 1. A
- 2. B
- 3. C
- 4. D

Question Number : 84 Question Type : MCQ Option Shuffling : No Display Question Number : Yes Single Line Question Option : No Option Orientation : Vertical

Correct Marks : 1 Wrong Marks : 0

What color is coded for the signal line of Servo?

- a. Red
- b. Orange
- c. Black
- d. Brown

Options :

- 1. A
- 2. B
- 3. C
- 4. D

Question Number : 85 Question Type : MCQ Option Shuffling : No Display Question Number : Yes Single Line Question Option : No Option Orientation : Vertical

Correct Marks : 1 Wrong Marks : 0

What is the limitation with using arduino board to supply the power to Servo?

- a. Draws more current and could damage the arduino board
- b. Voltage level isn't appropriate
- c. Servo can't be run with arduino
- d. Servo can turn abruptly

Options :

- 1. A
- 2. B
- 3. C
- 4. D

Question Number : 86 Question Type : MCQ Option Shuffling : No Display Question Number : Yes Single Line Question Option : No Option Orientation : Vertical

Correct Marks : 1 Wrong Marks : 0

What IC is used to externally supply power to Servo?

- a. 7809
- b. 7760
- c. 7812
- d. 7805

Options :

- 1. A
- 2. B
- 3. C
- 4. D

Question Number : 87 Question Type : MCQ Option Shuffling : No Display Question Number : Yes Single Line Question Option : No Option Orientation : Vertical

Correct Marks : 1 Wrong Marks : 0

How many PWM enabled pins are there in the arduino board ?

- a. 2
- b. 4
- c. 5
- d. 6

Options :

- 1. A

- 2. B
- 3. C
- 4. D

Question Number : 88 Question Type : MCQ Option Shuffling : No Display Question Number : Yes Single Line Question Option : No Option Orientation : Vertical

Correct Marks : 1 Wrong Marks : 0

What PWM pins become unusable after including the servo library?

- a. 9,10
- b. 11,12
- c. 13,14
- d. 2,3

Options :

- 1. A
- 2. B
- 3. C
- 4. D

Question Number : 89 Question Type : MCQ Option Shuffling : No Display Question Number : Yes Single Line Question Option : No Option Orientation : Vertical

Correct Marks : 1 Wrong Marks : 0

What library that must be added to run Servo motor?

- a. servo.h
- b. math.h
- c. servomotor.h
- d. Motor.h

Options :

- 1. A
- 2. B
- 3. C
- 4. D

Question Number : 90 Question Type : MCQ Option Shuffling : No Display Question Number : Yes Single Line Question Option : No Option Orientation : Vertical

Correct Marks : 1 Wrong Marks : 0

What transistor was used to vary the speed of DC motor ?

- a. npn-2221
- b. npn-2222
- c. npn-2442
- d. npn-2228

Options :

- 1. A
- 2. B
- 3. C
- 4. D

Question Number : 91 Question Type : MCQ Option Shuffling : No Display Question Number : Yes Single Line Question Option : No Option Orientation : Vertical

Correct Marks : 1 Wrong Marks : 0

How to change the orientation of the motor rotation?

- a. changing terminals of input
- b. changing the motor setup
- c. use h bridge ic.
- d. use a transistor

Options :

- 1. A
- 2. B
- 3. C
- 4. D

Question Number : 92 Question Type : MCQ Option Shuffling : No Display Question Number : Yes Single Line Question Option : No Option Orientation : Vertical

Correct Marks : 1 Wrong Marks : 0

What IC is used as a h-bridge IC?

- a. L293D
- b. L100N
- c. L4094N
- d. L74133

Options :

- 1. A
- 2. B
- 3. C

4. D

Question Number : 93 Question Type : MCQ Option Shuffling : No Display Question Number : Yes Single Line Question Option : No Option Orientation : Vertical

Correct Marks : 1 Wrong Marks : 0

How many pin IC is L293D?

- a. 8
- b. 12
- c. 16
- d. 24

Options :

- 1. A
- 2. B
- 3. C
- 4. D

Question Number : 94 Question Type : MCQ Option Shuffling : No Display Question Number : Yes Single Line Question Option : No Option Orientation : Vertical

Correct Marks : 1 Wrong Marks : 0

To what pins of arduino do the control terminals of L293D be connected ?

- a. any PWM enabled pin
- b. any digital pin
- c. Tx and Rx of arduino
- d. VCC and GND

Options :

- 1. A
- 2. B
- 3. C
- 4. D

Question Number : 95 Question Type : MCQ Option Shuffling : No Display Question Number : Yes Single Line Question Option : No Option Orientation : Vertical

Correct Marks : 1 Wrong Marks : 0

To what pins of arduino should the enable pins of L293D be connected?

- a. any digital pins
- b. any PWM pins
- c. any supply pins
- d. not to connect to arduino

Options :

- 1. A

2. B
3. C
4. D

Question Number : 96 Question Type : MCQ Option Shuffling : No Display Question Number : Yes Single Line Question Option : No Option Orientation : Vertical

Correct Marks : 1 Wrong Marks : 0

Which of the following subjects, that can be learnt using Arduino

- a. Digital Design and Control Systems.
- b. Signal Processing and Communication.
- c. Both a and b
- d. None of the above

Options :

1. A
2. B
3. C
4. D

Question Number : 97 Question Type : MCQ Option Shuffling : No Display Question Number : Yes Single Line Question Option : No Option Orientation : Vertical

Correct Marks : 1 Wrong Marks : 0

Programming language that can be used with Arduino

- a. C Language
- b. Wiring C
- c. Assembly
- d. All the above

Options :

1. A
2. B
3. C
4. D

Question Number : 98 Question Type : MCQ Option Shuffling : No Display Question Number : Yes Single Line Question Option : No Option Orientation : Vertical

Correct Marks : 1 Wrong Marks : 0

Raspberry pi is a

- a. Micro controller
- b. Microprocessor
- c. Single Board Computer
- d. None of the above

Options :

- 1. A
- 2. B
- 3. C
- 4. D

Question Number : 99 Question Type : MCQ Option Shuffling : No Display Question Number : Yes Single Line Question Option : No Option Orientation : Vertical

Correct Marks : 1 Wrong Marks : 0

Number of GPIO pins present in Raspberry Pi ?

- a. 10
- b. 20
- c. 30
- d. 40

Options :

- 1. A
- 2. B
- 3. C
- 4. D

Question Number : 100 Question Type : MCQ Option Shuffling : No Display Question Number : Yes Single Line Question Option : No Option Orientation : Vertical

Correct Marks : 1 Wrong Marks : 0

Command used to install VNC Server in Pi

- a. `sudo apt-get install vnc4server`
- b. `sudo apt install vnc4server`
- c. `sudo apt-get install vncserver`
- d. Both a and b

Options :

- 1. A
- 2. B
- 3. C

