

nta

Question Paper Name :	B TECH EO 26th Feb 2021 Shift 2
Subject Name :	B TECH EO
Creation Date :	2021-02-25 13:56:18
Duration :	180
Number of Questions :	90
Total Marks :	300
Display Marks:	Yes

B TECH EO

Group Number :	1
Group Id :	708191236
Group Maximum Duration :	0
Group Minimum Duration :	180
Show Attended Group? :	No
Edit Attended Group? :	No
Break time :	0
Group Marks :	300
Is this Group for Examiner? :	No

Physics Section A

Section Id :	708191994
Section Number :	1
Section type :	Online

Mandatory or Optional :	Mandatory
Number of Questions :	20
Number of Questions to be attempted :	20
Section Marks :	80
Mark As Answered Required? :	Yes
Sub-Section Number :	1
Sub-Section Id :	7081911274
Question Shuffling Allowed :	Yes

Question Number : 1 Question Id : 70819121814 Question Type : MCQ Option Shuffling : Yes Is Question Mandatory : No

Correct Marks : 4 Wrong Marks : 1

A radioactive sample is undergoing α decay. At any time t_1 , its activity is A and another time t_2 , the activity is $\frac{A}{5}$. What is the average life time for the sample ?

Options :

70819170591. $\frac{\ln 5}{t_2 - t_1}$

70819170592. $\frac{\ln(t_2 + t_1)}{2}$

70819170593. $\frac{t_2 - t_1}{\ln 5}$

70819170594. $\frac{t_1 - t_2}{\ln 5}$

Question Number : 1 Question Id : 70819121814 Question Type : MCQ Option Shuffling : Yes Is Question Mandatory : No

Correct Marks : 4 Wrong Marks : 1

ଗୋଟିଏ ତେଜସ୍ୱିୟ ନମୁନାର α ରଶ୍ମି କ୍ଷୟ ହେଉଅଛି । କୌଣସି ସମୟ t_1 ରେ ଏହାର ଅନୁଜ୍ଞାପନ A ଅଟେ ଏବଂ ଅନ୍ୟ ଏକ ସମୟ t_2 ରେ ଅନୁଜ୍ଞାପନ $\frac{A}{5}$ ହୁଏ । ନମୁନାଟି ପାଇଁ ହାରାହାରି ଆୟୁ କେତେ ଅଟେ ?

Options :

70819170591. $\frac{\ln 5}{t_2 - t_1}$

70819170592. $\frac{\ln(t_2 + t_1)}{2}$

70819170593. $\frac{t_2 - t_1}{\ln 5}$

70819170594. $\frac{t_1 - t_2}{\ln 5}$

Question Number : 2 Question Id : 70819121815 Question Type : MCQ Option Shuffling : Yes Is

Question Mandatory : No

Correct Marks : 4 Wrong Marks : 1

Given below are two statements : one is labeled as Assertion A and the other is labeled as Reason R.

Assertion A : For a simple microscope, the angular size of the object equals the angular size of the image.

Reason R : Magnification is achieved as the small object can be kept much closer to the eye than 25 cm and hence it subtends a large angle.

In the light of the above statements, choose the most appropriate answer from the options given below :

Options :

70819170595. Both A and R are true and R is the correct explanation of A

70819170596. Both A and R are true but R is NOT the correct explanation of A

70819170597. A is true but R is false

70819170598. A is false but R is true

Question Number : 2 Question Id : 70819121815 Question Type : MCQ Option Shuffling : Yes Is

Question Mandatory : No

Correct Marks : 4 Wrong Marks : 1

ନିମ୍ନରେ ଦୁଇଟି ଉକ୍ତି ଦିଆଯାଇଛି । ଗୋଟିଏ ଘୋଷଣା A ଓ ଅନ୍ୟଟି କାରଣ R ଭାବରେ ଚିହ୍ନିତ କରାଯାଇଛି ।

ଘୋଷଣା A : ଗୋଟିଏ ସରଳ ଅଣୁବିକ୍ଷଣ ଯନ୍ତ୍ର ପାଇଁ ବସ୍ତୁଟିର କୌଣସି ଆକାର ପ୍ରତିବିମ୍ବର କୌଣସି ଆକାର ସହ ସମାନ ।

କାରଣ R : କ୍ଷୁଦ୍ର ବସ୍ତୁଟିକୁ ଆଖିଠାରୁ 25 cm ଦୂରତାରେ ବସ୍ତୁତ କମ୍ ଦୂରତାରେ ରଖାଯାଇପାରୁଥିବାରୁ ବର୍ଦ୍ଧନ ସାଧନ ହୋଇଥାଏ ଏବଂ ସେଥିପାଇଁ ଏହା ଏକ ବୃହତ୍ତ କୋଣ କରିଥାଏ ।

ଉପରୋକ୍ତ ଉକ୍ତି ଗୁଡ଼ିକ ଅନୁସାରେ, ତଳେ ଦିଆଯାଇଥିବା ବିକଳଗୁଡ଼ିକ ମଧ୍ୟରୁ ଠିକ୍ ଉତ୍ତରଟି ଚୟନ କରନ୍ତୁ :

Options :

70819170595. ଉଭୟ A ଏବଂ R ସତ୍ୟ ଅଟନ୍ତି ଏବଂ A ର ଠିକ୍ ବ୍ୟାଖ୍ୟା R ଅଟେ ।

70819170596. ଉଭୟ A ଏବଂ R ସତ୍ୟ ଅଟନ୍ତି ଏବଂ A ର ଠିକ୍ ବ୍ୟାଖ୍ୟା R ନୁହେଁ ।

70819170597. A ସତ୍ୟ ଅଟେ କିନ୍ତୁ R ଭୁଲ୍ ଅଟେ ।

70819170598. A ଭୁଲ୍ ଅଟେ କିନ୍ତୁ R ଠିକ୍ ଅଟେ ।

Question Number : 3 Question Id : 70819121816 Question Type : MCQ Option Shuffling : Yes Is

Question Mandatory : No

Correct Marks : 4 Wrong Marks : 1

A tuning fork A of unknown frequency produces 5 beats/s with a fork of known frequency 340 Hz. When fork A is filed, the beat frequency decreases to 2 beats/s. What is the frequency of fork A ?

Options :

70819170599. 335 Hz

70819170600. 338 Hz

70819170601. 345 Hz

70819170602. 342 Hz

Question Number : 3 Question Id : 70819121816 Question Type : MCQ Option Shuffling : Yes Is Question Mandatory : No

Correct Marks : 4 Wrong Marks : 1

ଅଜଣା ଆବୃତ୍ତି ବାଲା ଗୋଟିଏ ଟ୍ୟୁନିଙ୍ଗ୍ ଫର୍କ (A) 340 Hz ଆବୃତ୍ତି ବିଶିଷ୍ଟ ଏକ ଜଣା ଟ୍ୟୁନିଙ୍ଗ୍ ଫର୍କ ସହ ସେକେଣ୍ଡ ପ୍ରତି 5 ବିସ୍ମୟ(ବିଚ୍ଚ) ସୃଷ୍ଟି କରିଥାଏ । ଯେତେବେଳେ ଟ୍ୟୁନିଙ୍ଗ୍ ଫର୍କ A କୁ ଘୋରି ଦିଆଯାଏ (ଫାଇଲଡ୍), ବିସ୍ମୟ ଆବୃତ୍ତି 2 ବିସ୍ମୟ/ସେକେଣ୍ଡ କୁ କମିଯାଏ । ଟ୍ୟୁନିଙ୍ଗ୍ ଫର୍କ (A) ର ଆବୃତ୍ତି କେତେ ?

Options :

70819170599. 335 Hz

70819170600. 338 Hz

70819170601. 345 Hz

70819170602. 342 Hz

Question Number : 4 Question Id : 70819121817 Question Type : MCQ Option Shuffling : Yes Is Question Mandatory : No

Correct Marks : 4 Wrong Marks : 1

Draw the output signal Y in the given combination of gates.

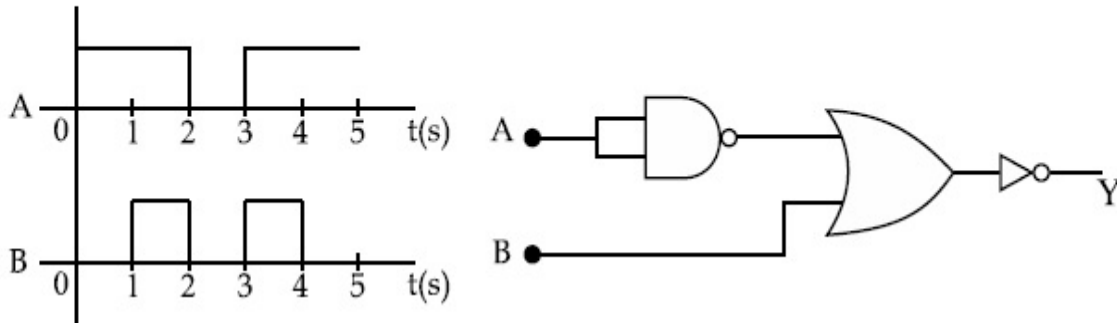

Options :

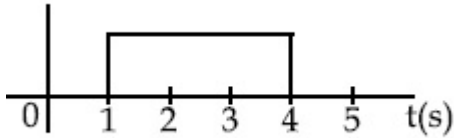

70819170603.

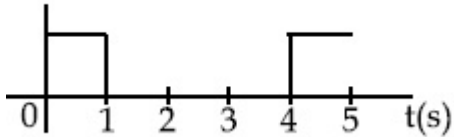

70819170604.

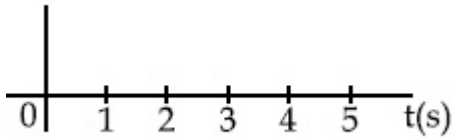

70819170605.

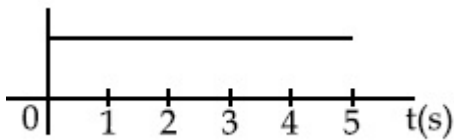

70819170606.

Question Number : 4 Question Id : 70819121817 Question Type : MCQ Option Shuffling : Yes Is Question Mandatory : No

Correct Marks : 4 Wrong Marks : 1

ଗେଟ୍ ଗୁଡ଼ିକର ଦିଆଯାଇଥିବା ସଂକ୍ଷିପ୍ତ ବର୍ତ୍ତମାନ ସିଗ୍ନାଲ୍ ଅଙ୍କନ କର ।

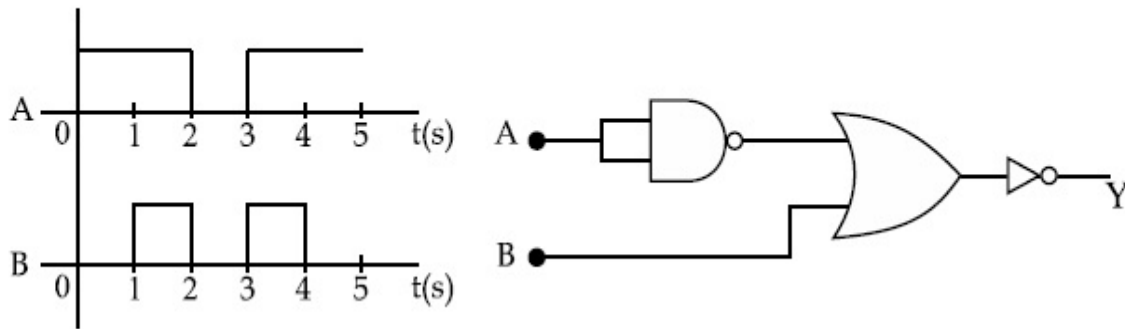

Options :

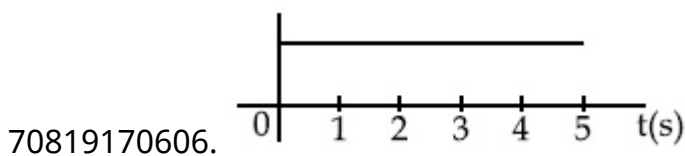
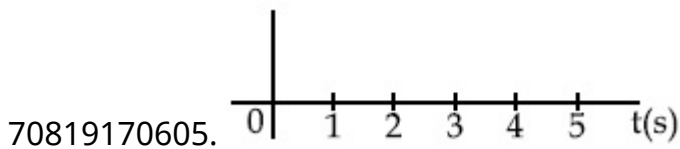
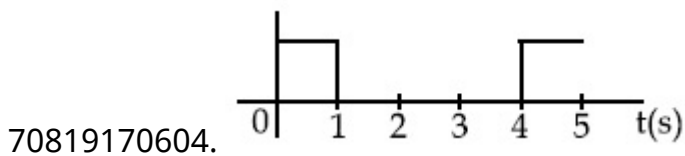
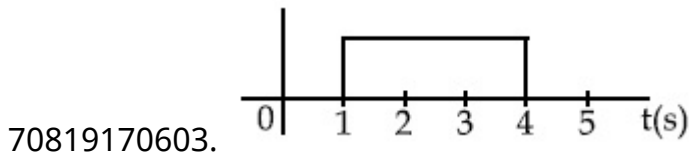

Question Number : 5 Question Id : 70819121818 Question Type : MCQ Option Shuffling : Yes Is

Question Mandatory : No

Correct Marks : 4 Wrong Marks : 1

Given below are two statements :

Statement I : A second's pendulum has a time period of 1 second.

Statement II : It takes precisely one second to move between the two extreme positions.

In the light of the above statements, choose the correct answer from the options given below :

Options :

70819170607. Both Statement I and Statement II are true

70819170608. Both Statement I and Statement II are false

70819170609. Statement I is true but Statement II is false

70819170610. Statement I is false but Statement II is true

Question Number : 5 Question Id : 70819121818 Question Type : MCQ Option Shuffling : Yes Is

Question Mandatory : No

Correct Marks : 4 Wrong Marks : 1

ନିମ୍ନରେ ଦୁଇଟି ଉକ୍ତି ଦିଆଯାଇଛି ।

ଉକ୍ତି I : ଗୋଟିଏ ସେକେଣ୍ଡ୍ ପେଣ୍ଡୁଲମ୍‌ର ଆବର୍ତ୍ତକାଳ 1 ସେକେଣ୍ଡ୍ ।

ଉକ୍ତି II : ଦୁଇଟି ଦୂରବର୍ତ୍ତୀ ସ୍ଥାନ ମଧ୍ୟରେ ଗତି କରିବା ପାଇଁ ଏହା ସଠିକ୍ ଭାବେ ଏକ ସେକେଣ୍ଡ୍ ନେଇଥାଏ ।

ଉପରୋକ୍ତ ଉକ୍ତିଗୁଡ଼ିକ ଅନୁସାରେ, ନିମ୍ନରେ ଦତ୍ତ ବିକଳ୍ପଗୁଡ଼ିକ ମଧ୍ୟରୁ ଠିକ୍ ଉତ୍ତରଟି ଚୟନ କର :

Options :

70819170607. ଉଭୟ ଉକ୍ତି I ଏବଂ ଉକ୍ତି II ସତ୍ୟ ଅଟେ ।

70819170608. ଉଭୟ ଉକ୍ତି I ଏବଂ ଉକ୍ତି II ମିଥ୍ୟା ଅଟେ ।

70819170609. ଉକ୍ତି I ଠିକ୍ ଅଟେ କିନ୍ତୁ ଉକ୍ତି II ଠିକ୍ ମିଥ୍ୟା ଅଟେ ।

70819170610. ଉକ୍ତି I ଠିକ୍ ଭୁଲ୍ କିନ୍ତୁ ଉକ୍ତି II ଠିକ୍ ସତ୍ୟ ଅଟେ ।

Question Number : 6 Question Id : 70819121819 Question Type : MCQ Option Shuffling : Yes Is

Question Mandatory : No

Correct Marks : 4 Wrong Marks : 1

If 'C' and 'V' represent capacity and voltage respectively then what are the dimensions of λ where $C/V = \lambda$?

Options :

70819170611. $[M^{-2} L^{-3} I^2 T^6]$

70819170612. $[M^{-3} L^{-4} I^3 T^7]$

70819170613. $[M^{-2} L^{-4} I^3 T^7]$

70819170614. $[M^{-1} L^{-3} I^{-2} T^{-7}]$

Question Number : 6 Question Id : 70819121819 Question Type : MCQ Option Shuffling : Yes Is Question Mandatory : No

Correct Marks : 4 Wrong Marks : 1

ଯଦି 'C' ଏବଂ 'V' ଯଥାକ୍ରମେ ଧାରିତା ଏବଂ ବିଭବକୁ ବୁଝାଇଥାଏ ତେବେ 'λ' ର ବିମିତି ଗୁଡ଼ିକ କ'ଣ ହେବ ଯେଉଁଠି $C/V = \lambda$?

Options :

70819170611. $[M^{-2} L^{-3} I^2 T^6]$

70819170612. $[M^{-3} L^{-4} I^3 T^7]$

70819170613. $[M^{-2} L^{-4} I^3 T^7]$

70819170614. $[M^{-1} L^{-3} I^{-2} T^{-7}]$

Question Number : 7 Question Id : 70819121820 Question Type : MCQ Option Shuffling : Yes Is Question Mandatory : No

Correct Marks : 4 Wrong Marks : 1

An aeroplane, with its wings spread 10 m, is flying at a speed of 180 km/h in a horizontal direction. The total intensity of earth's field at that part is 2.5×10^{-4} Wb/m² and the angle of dip is 60°. The emf induced between the tips of the plane wings will be _____.

Options :

70819170615. 108.25 mV

70819170616. 62.50 mV

70819170617. 88.37 mV

70819170618. 54.125 mV

Question Number : 7 Question Id : 70819121820 Question Type : MCQ Option Shuffling : Yes Is

Question Mandatory : No

Correct Marks : 4 Wrong Marks : 1

10 m ଚଉଡ଼ାର ଡେଣା ବିଶିଷ୍ଟ ଗୋଟିଏ ଉଡ଼ାଜାହାଜ ଭୂସମାନ୍ତର ଦିଗରେ 180 km/h ବେଗରେ ଉଡୁଅଛି । ସେହି ଅଂଶରେ ଭୂରୁମ୍ବନାୟକ କ୍ଷେତ୍ରର ଚାନ୍ଦ୍ରତା 2.5×10^{-4} Wb/m² ଏବଂ ତ୍ରିପକୋଣ 60° ଅଟେ । ଉଡ଼ାଜାହାଜ ଡେଣାର ଅଗ୍ର ଦୁଇଟି ମଧ୍ୟରେ ପ୍ରେରିତ ବିଦ୍ୟୁତ୍ ବାହକ ବଳ ହେବ _____ ।

Options :

70819170615. 108.25 mV

70819170616. 62.50 mV

70819170617. 88.37 mV

70819170618. 54.125 mV

Question Number : 8 Question Id : 70819121821 Question Type : MCQ Option Shuffling : Yes Is

Question Mandatory : No

Correct Marks : 4 Wrong Marks : 1

A cord is wound round the circumference of wheel of radius r . The axis of the wheel is horizontal and the moment of inertia about it is I . A weight mg is attached to the cord at the end. The weight falls from rest. After falling through a distance 'h', the square of angular velocity of wheel will be :

Options :

70819170619. $2gh$

70819170620. $\frac{2gh}{I + mr^2}$

70819170621. $\frac{2mgh}{I + mr^2}$

70819170622. $\frac{2mgh}{I + 2mr^2}$

Question Number : 8 Question Id : 70819121821 Question Type : MCQ Option Shuffling : Yes Is

Question Mandatory : No

Correct Marks : 4 Wrong Marks : 1

r ବ୍ୟାସାର୍ଦ୍ଧ ବିଶିଷ୍ଟ ଏକ ଚକ (ହୁଲ)ର ଚାରିପଟେ ଗୋଟିଏ ରଜୁକୁ (କର୍ଡ୍) ଗୁଡ଼ାଯାଇଛି । ଚକଟିର ଅକ୍ଷ ଭୂସମାନ୍ତର ହୋଇ ରହିଛି ଏବଂ ଏହା ଚତୁର୍ଦ୍ଦିଗରେ ଆୟତ୍ତ ଜଡ଼ତ୍ୱ I ଅଟେ । ରଜୁଟିର ଶେଷ ମୁଣ୍ଡରେ mg ଓଜନଟିଏ ସଂଯୁକ୍ତ କରାଯାଇଛି । ଓଜନଟି ସ୍ଥିର ଅବସ୍ଥାରୁ ଖସୁଛି । 'h' ଦୂରତା ଖସିଲା ପରେ, ଚକଟିର କୌଣସି ବେଗର ବର୍ଗ ହେବ _____ ।

Options :

70819170619. $2gh$

70819170620. $\frac{2gh}{I + mr^2}$

70819170621. $\frac{2mgh}{I + mr^2}$

70819170622.

$$\frac{2mgh}{I + 2mr^2}$$

Question Number : 9 Question Id : 70819121822 Question Type : MCQ Option Shuffling : Yes Is

Question Mandatory : No

Correct Marks : 4 Wrong Marks : 1

The trajectory of a projectile in a vertical plane is $y = \alpha x - \beta x^2$, where α and β are constants and x & y are respectively the horizontal and vertical distances of the projectile from the point of projection. The angle of projection θ and the maximum height attained H are respectively given by :

Options :

70819170623. $\tan^{-1}\beta, \frac{\alpha^2}{2\beta}$

70819170624. $\tan^{-1}\left(\frac{\beta}{\alpha}\right), \frac{\alpha^2}{\beta}$

70819170625. $\tan^{-1}\alpha, \frac{\alpha^2}{4\beta}$

70819170626. $\tan^{-1}\alpha, \frac{4\alpha^2}{\beta}$

Question Number : 9 Question Id : 70819121822 Question Type : MCQ Option Shuffling : Yes Is

Question Mandatory : No

Correct Marks : 4 Wrong Marks : 1

ଗୋଟିଏ ପ୍ରୋଜେକ୍ଟାଇଲର ଭୂଲମ୍ବୀୟ ସମତଳରେ ପ୍ରକ୍ଷେପ ପଥ ଅଟେ $y = \alpha x - \beta x^2$, ଯେଉଁଠାରେ α , β ଦୁଇଟି ଛିରାକ ଅଟନ୍ତି ଓ x ଏବଂ y ଯଥାକ୍ରମେ କ୍ଷେପଣ ବିନ୍ଦୁରୁ ପ୍ରୋଜେକ୍ଟାଇଲର ଭୂସମାନ୍ତର ଓ ଭୂଲମ୍ବୀୟ ଦୂରତା ଅଟେ । ପ୍ରକ୍ଷେପ କୋଣ (θ) ଏବଂ ଲକ୍ଷ ସର୍ବାଧିକ ଉଚ୍ଚତା (H) ଯଥାକ୍ରମେ ହେବ :

Options :

70819170623.

$$\tan^{-1}\beta, \frac{\alpha^2}{2\beta}$$

70819170624.

$$\tan^{-1}\left(\frac{\beta}{\alpha}\right), \frac{\alpha^2}{\beta}$$

70819170625.

$$\tan^{-1}\alpha, \frac{\alpha^2}{4\beta}$$

70819170626.

$$\tan^{-1}\alpha, \frac{4\alpha^2}{\beta}$$

Question Number : 10 Question Id : 70819121823 Question Type : MCQ Option Shuffling : Yes

Is Question Mandatory : No

Correct Marks : 4 Wrong Marks : 1

Two masses A and B, each of mass M are fixed together by a massless spring. A force acts on the mass B as shown in figure. If the mass A starts moving away from mass B with acceleration 'a', then the acceleration of mass B will be :

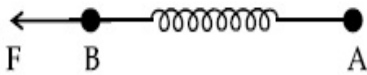

Options :

70819170627.
$$\frac{MF}{F + Ma}$$

70819170628.
$$\frac{F + Ma}{M}$$

70819170629.
$$\frac{Ma - F}{M}$$

70819170630.

$$\frac{F - Ma}{M}$$

Question Number : 10 Question Id : 70819121823 Question Type : MCQ Option Shuffling : Yes

Is Question Mandatory : No

Correct Marks : 4 Wrong Marks : 1

ଗୋଟିଏ ବସ୍ତୁଦ୍ୱିତୀୟକ ଶ୍ରେଣୀ ଦ୍ୱାରା ପ୍ରତ୍ୟେକ M ବସ୍ତୁ ବିଶିଷ୍ଟ ଦୁଇଟି ବସ୍ତୁ A ଏବଂ B କୁ ପରସ୍ପର ସହ ସଂଯୁକ୍ତ କରାଯାଇଛି । ଚିତ୍ରରେ ଦର୍ଶାଯାଇଥିବା ଅନୁସାରେ ଗୋଟିଏ ବଳ (F) B ବସ୍ତୁ ଉପରେ କାର୍ଯ୍ୟ କରୁଅଛି । ଯଦି a ତ୍ୱରଣ ସହ A ବସ୍ତୁଟି B ବସ୍ତୁ ଠାରୁ ଦୂରେଇଯିବା ଆରମ୍ଭ କରିବ, ତେବେ B ବସ୍ତୁଟିର ତ୍ୱରଣ ହେବ :

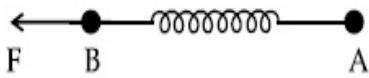

Options :

70819170627. $\frac{MF}{F + Ma}$

70819170628. $\frac{F + Ma}{M}$

70819170629. $\frac{Ma - F}{M}$

70819170630. $\frac{F - Ma}{M}$

Question Number : 11 Question Id : 70819121824 Question Type : MCQ Option Shuffling : Yes

Is Question Mandatory : No

Correct Marks : 4 Wrong Marks : 1

Given below are two statements :

Statement I : An electric dipole is placed at the centre of a hollow sphere. The flux of electric field through the sphere is zero but the electric field is not zero anywhere in the sphere.

Statement II : If R is the radius of a solid metallic sphere and Q be the total charge on it. The electric field at any point on the spherical surface of radius r ($< R$) is zero but the electric flux passing through this closed spherical surface of radius r is not zero.

In the light of the above statements, choose the correct answer from the options given below :

Options :

70819170631. Both Statement I and Statement II are true

70819170632. Both Statement I and Statement II are false

70819170633. Statement I is true but Statement II is false

70819170634. Statement I is false but Statement II is true

Question Number : 11 Question Id : 70819121824 Question Type : MCQ Option Shuffling : Yes

Is Question Mandatory : No

Correct Marks : 4 Wrong Marks : 1

ନିମ୍ନରେ ଦୁଇଟି ଉକ୍ତି ଦିଆଯାଇଛି :

ଉକ୍ତି I : ଗୋଟିଏ ଫମ୍ପା ଗୋଲକର କେନ୍ଦ୍ରରେ ଏକ ବୈଦ୍ୟୁତିକ ଦ୍ଵିଧ୍ରୁବ ରଖାଯାଇଛି । ଗୋଲକ ମଧ୍ୟ ଦେଇ ଯାଉଥିବା ବୈଦ୍ୟୁତିକ ଫ୍ଲକ୍ସ ଶୂନ୍ୟ ଅଟେ କିନ୍ତୁ ଗୋଲକ ମଧ୍ୟରେ ଅନ୍ୟ କେଉଁଠି ବୈଦ୍ୟୁତିକ କ୍ଷେତ୍ର ଶୂନ୍ୟ ନୁହେଁ ।

ଉକ୍ତି II : ଯଦି ଗୋଟିଏ ନିଦା ଧାତବ ଗୋଲକର ବ୍ୟାସାର୍ଦ୍ଧ R ଏବଂ ଏଥିରେ ଥିବା ସମୁଦାୟ ଚାର୍ଜ Q ଅଟେ, r ($< R$) ବ୍ୟାସାର୍ଦ୍ଧ ବିଶିଷ୍ଟ ଗୋଲାକାର ପୃଷ୍ଠତଳର ଯେକୌଣସି ବିନ୍ଦୁରେ ବୈଦ୍ୟୁତିକ କ୍ଷେତ୍ର ଶୂନ୍ୟ ଅଟେ କିନ୍ତୁ ଏହି r ବ୍ୟାସାର୍ଦ୍ଧ ବିଶିଷ୍ଟ ନିବୁଜ ଗୋଲାକାର ପୃଷ୍ଠତଳ ମଧ୍ୟଦେଇ ଯାଉଥିବା ବୈଦ୍ୟୁତିକ ଫ୍ଲକ୍ସ ଶୂନ୍ୟ ନୁହେଁ ।

ଉପରୋକ୍ତ ଉକ୍ତି ଗୁଡ଼ିକ ଅନୁସାରେ, ନିମ୍ନରେ ଦତ୍ତ ବିକଳ ଗୁଡ଼ିକ ମଧ୍ୟରୁ ଠିକ୍ ଉତ୍ତରଟି ଚୟନ କର :

Options :

70819170631. ଉଭୟ ଉକ୍ତି I ଏବଂ ଉକ୍ତି II ସତ୍ୟ ଅଟେ ।

70819170632. ଉଭୟ ଉକ୍ତି I ଏବଂ ଉକ୍ତି II ମିଥ୍ୟା ଅଟେ ।

70819170633. ଉକ୍ତି I ଠିକ୍ ଅଟେ କିନ୍ତୁ ଉକ୍ତି II ଠିକ୍ ନିଥାଏ ।

70819170634. ଉକ୍ତି I ଠିକ୍ ଭୁଲ୍ କିନ୍ତୁ ଉକ୍ତି II ଠିକ୍ ସତ୍ୟ ଅଟେ ।

**Question Number : 12 Question Id : 70819121825 Question Type : MCQ Option Shuffling : Yes
Is Question Mandatory : No**

Correct Marks : 4 Wrong Marks : 1

A scooter accelerates from rest for time t_1 at constant rate a_1 and then retards at constant rate a_2 for time t_2 and comes to rest. The correct value of $\frac{t_1}{t_2}$ will be :

Options :

70819170635. $\frac{a_1}{a_2}$

70819170636. $\frac{a_2}{a_1}$

70819170637. $\frac{a_1 + a_2}{a_1}$

70819170638. $\frac{a_1 + a_2}{a_2}$

**Question Number : 12 Question Id : 70819121825 Question Type : MCQ Option Shuffling : Yes
Is Question Mandatory : No**

Correct Marks : 4 Wrong Marks : 1

ଗୋଟିଏ ସ୍କୁଟର ଶୁଣ୍ଠିରୁ ଅବସ୍ଥାକୁ t_1 ସମୟ ପାଇଁ ଶୁଣ୍ଠିର ହାର a_1 ରେ ତ୍ୱରିତ ହୁଏ ଏବଂ ଏହାପରେ t_2 ସମୟ ପାଇଁ ଶୁଣ୍ଠିର ହାର a_2 ରେ ମନ୍ଦିତ ହୋଇ ବିରାମ ଅବସ୍ଥାକୁ ଆସିଥାଏ । $\frac{t_1}{t_2}$ ର ସଠିକ୍ ମୂଲ୍ୟ ହେବ _____ ।

Options :

70819170635. $\frac{a_1}{a_2}$

70819170636. $\frac{a_2}{a_1}$

70819170637. $\frac{a_1 + a_2}{a_1}$

70819170638. $\frac{a_1 + a_2}{a_2}$

Question Number : 13 Question Id : 70819121826 Question Type : MCQ Option Shuffling : Yes

Is Question Mandatory : No

Correct Marks : 4 Wrong Marks : 1

The internal energy (U), pressure (P) and volume (V) of an ideal gas are related as $U = 3PV + 4$.

The gas is :

Options :

70819170639. monoatomic only.

70819170640. diatomic only.

70819170641. polyatomic only.

70819170642. either monoatomic or diatomic.

Question Number : 13 Question Id : 70819121826 Question Type : MCQ Option Shuffling : Yes

Is Question Mandatory : No

Correct Marks : 4 Wrong Marks : 1

ଗୋଟିଏ ଆବର୍ଣ୍ଣ ଗ୍ୟାସ୍‌ର ଅତ୍ୟନ୍ତ ଶକ୍ତି (U), ଚାପ (P) ଏବଂ ଆୟତନ (V) ଗୁଡ଼ିକୁ $U=3PV+4$ ଆକାରରେ ପ୍ରକାଶ କରାଯାଏ ।

ଗ୍ୟାସ୍‌ଟି ହେଉଛି :

Options :

70819170639. କେବଳ ଏକ ପରମାଣୁକ

70819170640. କେବଳ ଦ୍ଵିପରମାଣୁକ

70819170641. କେବଳ ବହୁପରମାଣୁକ

70819170642. ଏକ ପରମାଣୁକ ବା ଦ୍ଵିପରମାଣୁକ

Question Number : 14 Question Id : 70819121827 Question Type : MCQ Option Shuffling : Yes

Is Question Mandatory : No

Correct Marks : 4 Wrong Marks : 1

The recoil speed of a hydrogen atom after it emits a photon in going from $n=5$ state to $n=1$ state will be :

Options :

70819170643. 4.34 m/s

70819170644. 4.17 m/s

70819170645. 3.25 m/s

70819170646. 2.19 m/s

Question Number : 14 Question Id : 70819121827 Question Type : MCQ Option Shuffling : Yes

Is Question Mandatory : No

Correct Marks : 4 Wrong Marks : 1

$n=5$ ଅବସ୍ଥାରୁ $n=1$ ଅବସ୍ଥାକୁ ଯିବାବେଳେ ଉଦ୍‌ୟାନ ପରମାଣୁଟିଏ ଗୋଟିଏ ଫୋଟନ୍ ନିର୍ଗତ କଲାପରେ ଏହାର ପଶ୍ଚାତ୍‌ଗାମୀ ବେଗ ହେବ :

Options :

70819170643. 4.34 m/s

70819170644. 4.17 m/s

70819170645. 3.25 m/s

70819170646. 2.19 m/s

Question Number : 15 Question Id : 70819121828 Question Type : MCQ Option Shuffling : Yes

Is Question Mandatory : No

Correct Marks : 4 Wrong Marks : 1

The length of metallic wire is l_1 when tension in it is T_1 . It is l_2 when the tension is T_2 . The original length of the wire will be :

Options :

70819170647. $\frac{l_1 + l_2}{2}$

70819170648. $\frac{T_2 l_1 + T_1 l_2}{T_1 + T_2}$

70819170649. $\frac{T_1 l_1 - T_2 l_2}{T_2 - T_1}$

70819170650.

$$\frac{T_2 l_1 - T_1 l_2}{T_2 - T_1}$$

Question Number : 15 Question Id : 70819121828 Question Type : MCQ Option Shuffling : Yes

Is Question Mandatory : No

Correct Marks : 4 Wrong Marks : 1

ଗୋଟିଏ ଧାତବ ତାରର ଦୈର୍ଘ୍ୟ l_1 ଅଟେ ଯେତେବେଳେ ଏଥିରେ ଥିବା ତନନ(ତେନସନ) T_1 ଅଟେ । ତନନ(ତେନସନ) T_2 ରେ ଏହାର ଦୈର୍ଘ୍ୟ l_2 ଅଟେ । ତାରଟିର ମୂଳ ଦୈର୍ଘ୍ୟ ହେଉଛି :

Options :

70819170647. $\frac{l_1 + l_2}{2}$

70819170648. $\frac{T_2 l_1 + T_1 l_2}{T_1 + T_2}$

70819170649. $\frac{T_1 l_1 - T_2 l_2}{T_2 - T_1}$

70819170650. $\frac{T_2 l_1 - T_1 l_2}{T_2 - T_1}$

Question Number : 16 Question Id : 70819121829 Question Type : MCQ Option Shuffling : Yes

Is Question Mandatory : No

Correct Marks : 4 Wrong Marks : 1

A particle executes S.H.M., the graph of velocity as a function of displacement is :

Options :

70819170651. a circle.

70819170652. a parabola.

70819170653. an ellipse.

70819170654. a helix.

Question Number : 16 Question Id : 70819121829 Question Type : MCQ Option Shuffling : Yes

Is Question Mandatory : No

Correct Marks : 4 Wrong Marks : 1

ଗୋଟିଏ କଣିକା ସରଳ ହାରମୋନିକ୍ ଗତି (ଏସ୍.ଏଚ୍.ଏମ୍) ସମ୍ପାଦନ କରୁଅଛି । ବିଚ୍ଛାପନର ଫଳନ ଆକାରରେ ପରିବେଗଟିର ଲେଖାଚିତ୍ରଟି ହେଉଛି :

Options :

70819170651. ଗୋଟିଏ ବୃତ୍ତ

70819170652. ଗୋଟିଏ ପରିବଳୟ (ପରାବୋଲା)

70819170653. ଗୋଟିଏ ଦୀର୍ଘବୃତ୍ତ (ଇଲିପ୍ସ)

70819170654. ଗୋଟିଏ କୁଣ୍ଡଳିନୀ (ହେଲିକ୍ସ)

Question Number : 17 Question Id : 70819121830 Question Type : MCQ Option Shuffling : Yes

Is Question Mandatory : No

Correct Marks : 4 Wrong Marks : 1

The incident ray, reflected ray and the outward drawn normal are denoted by the unit vectors \vec{a} , \vec{b} and \vec{c} respectively. Then choose the correct relation for these vectors.

Options :

70819170655. $\vec{b} = \vec{a} - \vec{c}$

70819170656.
$$\vec{b} = \vec{a} - 2(\vec{a} \cdot \vec{c})\vec{c}$$

70819170657.
$$\vec{b} = \vec{a} + 2\vec{c}$$

70819170658.
$$\vec{b} = 2\vec{a} + \vec{c}$$

Question Number : 17 Question Id : 70819121830 Question Type : MCQ Option Shuffling : Yes

Is Question Mandatory : No

Correct Marks : 4 Wrong Marks : 1

ଆପତ୍ତିତ ରଶ୍ମି, ପ୍ରତିଫଳିତ ରଶ୍ମି ଏବଂ ବାହ୍ୟମୁଖୀ ଲମ୍ବକୁ ଯଥାକ୍ରମେ ଏକକ ସଦିଶ \vec{a} , \vec{b} ଏବଂ \vec{c} ଦ୍ୱାରା ଚିହ୍ନିତ କରାଯାଇଛି । ତେବେ ଏହି ସଦିଶ ଗୁଡ଼ିକ ପାଇଁ ସଠିକ୍ ସମ୍ପର୍କଟି ଚୟନ କର ।

Options :

70819170655.
$$\vec{b} = \vec{a} - \vec{c}$$

70819170656.
$$\vec{b} = \vec{a} - 2(\vec{a} \cdot \vec{c})\vec{c}$$

70819170657.
$$\vec{b} = \vec{a} + 2\vec{c}$$

70819170658.
$$\vec{b} = 2\vec{a} + \vec{c}$$

Question Number : 18 Question Id : 70819121831 Question Type : MCQ Option Shuffling : Yes

Is Question Mandatory : No

Correct Marks : 4 Wrong Marks : 1

Find the peak current and resonant frequency of the following circuit (as shown in figure).

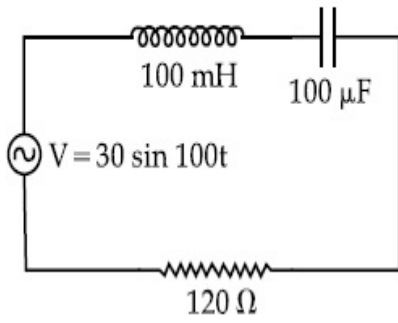

Options :

70819170659. 2 A and 50 Hz

70819170660. 0.2 A and 50 Hz

70819170661. 2 A and 100 Hz

70819170662. 0.2 A and 100 Hz

Question Number : 18 Question Id : 70819121831 Question Type : MCQ Option Shuffling : Yes

Is Question Mandatory : No

Correct Marks : 4 Wrong Marks : 1

ନିମ୍ନଲିଖିତ ପରିପଥ (ଚିତ୍ରରେ ଦର୍ଶାଯାଇଥିବା ଅନୁସାରେ) ର ଶୀର୍ଷ ବିଦ୍ୟୁତ୍ ସ୍ରୋତ ଏବଂ ଅନୁନାଦ ଆବୃତ୍ତି ବାହାର କର ।

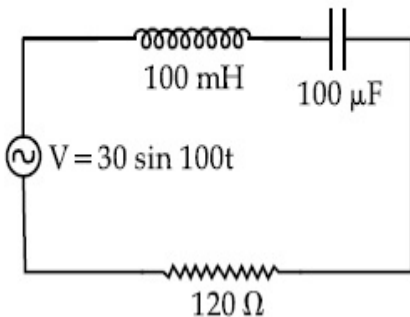

Options :

70819170659. 2 A ଏବଂ 50 Hz

70819170660. 0.2 A ଏବଂ 50 Hz

70819170661. 2 A \sphericalangle 100 Hz

70819170662. 0.2 A \sphericalangle 100 Hz

Question Number : 19 Question Id : 70819121832 Question Type : MCQ Option Shuffling : Yes

Is Question Mandatory : No

Correct Marks : 4 Wrong Marks : 1

An inclined plane making an angle of 30° with the horizontal is placed in a uniform horizontal electric field $200 \frac{\text{N}}{\text{C}}$ as shown in the figure. A body of mass 1 kg and charge 5 mC is allowed to slide down from rest at a height of 1 m. If the coefficient of friction is 0.2, find the time taken by the body to reach the bottom.

$$[g=9.8 \text{ m/s}^2; \sin 30^\circ = \frac{1}{2}; \cos 30^\circ = \frac{\sqrt{3}}{2}]$$

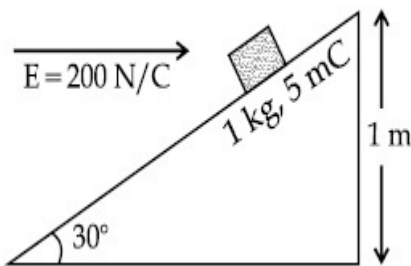

Options :

70819170663. 2.3 s

70819170664. 1.3 s

70819170665. 0.92 s

70819170666. 0.46 s

Question Number : 19 Question Id : 70819121832 Question Type : MCQ Option Shuffling : Yes

Is Question Mandatory : No

Correct Marks : 4 Wrong Marks : 1

ଚିତ୍ରରେ ଦର୍ଶାଯାଇଥିବା ଅନୁସାରେ $200 \frac{\text{N}}{\text{C}}$ ବିଶିଷ୍ଟ ଏକ ସମ ଭୂସମାନ୍ତର ବୈଦ୍ୟୁତିକ କ୍ଷେତ୍ରରେ ଭୂସମାନ୍ତର ସହ 30° କୋଣରେ ଏକ ତୀର୍ଣ୍ଣୀୟ ଧରାତଳ (ଇନ୍‌କ୍ଲାଇନ୍ ପ୍ଲେନ୍) ରଖାଯାଇଛି । 1 kg ବସ୍ତୁ ଏବଂ 5 mC ଚାର୍ଜ ବିଶିଷ୍ଟ ଗୋଟିଏ ବସ୍ତୁକୁ 1 m ଉଚ୍ଚତାରୁ ସ୍ଥିର ଅବସ୍ଥାରୁ ତଳ ଆଡ଼କୁ ଖସାଗଲା । ଯଦି ଘର୍ଷଣ ଧ୍ରୁବକ 0.2 ଅଟେ, ତଳେ ପହଞ୍ଚିବା ପାଇଁ ବସ୍ତୁଟି ନେଇଥିବା ସମୟ ନିରୂପଣ କର ।

$$[g=9.8 \text{ m/s}^2; \sin 30^\circ = \frac{1}{2}; \cos 30^\circ = \frac{\sqrt{3}}{2}]$$

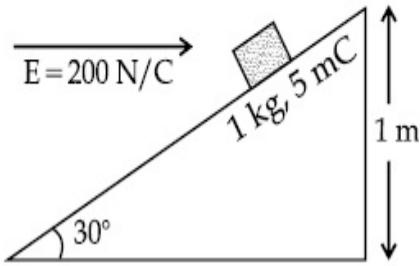

Options :

70819170663. 2.3 s

70819170664. 1.3 s

70819170665. 0.92 s

70819170666. 0.46 s

Question Number : 20 Question Id : 70819121833 Question Type : MCQ Option Shuffling : Yes

Is Question Mandatory : No

Correct Marks : 4 Wrong Marks : 1

A wire of 1Ω has a length of 1 m . It is stretched till its length increases by 25% . The percentage change in resistance to the nearest integer is :

Options :

70819170667. 76 %

70819170668. 56 %

70819170669. 25%

70819170670. 12.5%

**Question Number : 20 Question Id : 70819121833 Question Type : MCQ Option Shuffling : Yes
Is Question Mandatory : No**

Correct Marks : 4 Wrong Marks : 1

1 Ω ର ଏକ ଡାଇର ଡିଫିଜି 1 m ରହିଛି । ଏହାର ଡିଫିଜି 25% ବୃଦ୍ଧି ପାଇବା ପର୍ଯ୍ୟନ୍ତ ପ୍ରସାରିତ କରାଗଲା । ପ୍ରତିରୋଧରେ ହେଉଥିବା ଶତକଡ଼ା ପରିବର୍ତ୍ତନ ପାଖାପାଖି ପୂର୍ଣ୍ଣସଂଖ୍ୟାରେ ହେବ _____ ।

Options :

70819170667. 76%

70819170668. 56%

70819170669. 25%

70819170670. 12.5%

Physics Section B

Section Id :	708191995
Section Number :	2
Section type :	Online
Mandatory or Optional :	Mandatory
Number of Questions :	10
Number of Questions to be attempted :	5
Section Marks :	20
Mark As Answered Required? :	Yes

Sub-Section Number :

1

Sub-Section Id :

7081911275

Question Shuffling Allowed :

Yes

Question Number : 21 Question Id : 70819121834 Question Type : SA

Correct Marks : 4 Wrong Marks : 0

The zener diode has a $V_z = 30$ V. The current passing through the diode for the following circuit is _____ mA.

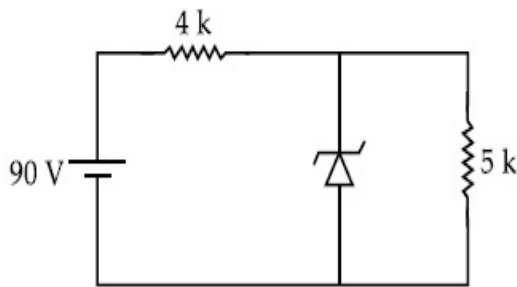

Response Type : Numeric

Evaluation Required For SA : Yes

Show Word Count : Yes

Answers Type : Range

Text Areas : PlainText

Possible Answers :

5 to 5.001

Question Number : 21 Question Id : 70819121834 Question Type : SA

Correct Marks : 4 Wrong Marks : 0

ଜିନର ଭୋଲଟେଜ୍ $V_z = 30$ V ରହିଛି ।

ତଳେ ଦିଆଯାଇଥିବା ପରିପଥରେ ଭୋଲଟେଜ୍ ମଧ୍ୟରେ ଗତି କରୁଥିବା ବିଦ୍ୟୁତ୍ ପ୍ରବାହ ହେବ _____ mA ।

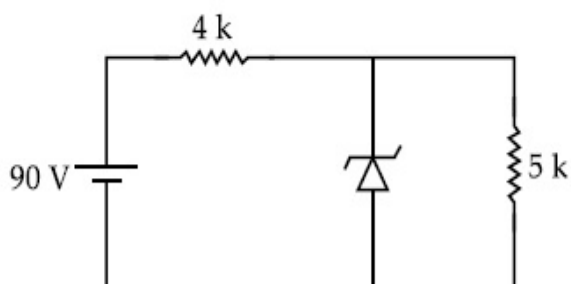

Response Type : Numeric

Evaluation Required For SA : Yes

Show Word Count : Yes

Answers Type : Range

Text Areas : PlainText

Possible Answers :

5 to 5.001

Question Number : 22 **Question Id :** 70819121835 **Question Type :** SA

Correct Marks : 4 **Wrong Marks :** 0

Time period of a simple pendulum is T . The time taken to complete $\frac{5}{8}$ oscillations starting from mean position is $\frac{\alpha}{\beta}T$. The value of α is _____.

Response Type : Numeric

Evaluation Required For SA : Yes

Show Word Count : Yes

Answers Type : Range

Text Areas : PlainText

Possible Answers :

5 to 5.001

Question Number : 22 **Question Id :** 70819121835 **Question Type :** SA

Correct Marks : 4 **Wrong Marks :** 0

ଗୋଟିଏ ସରଳ ପେଣ୍ଡୁଲମ୍ ଆବର୍ତ୍ତକାଳ T ଅଟେ । ମାଧ୍ୟ ସ୍ଥାନରୁ ଆରମ୍ଭ କରି $\frac{5}{8}$ ଦୋଳନ ସମ୍ପୂର୍ଣ୍ଣ କରିବା ପାଇଁ $\frac{\alpha}{\beta}T$ ସମୟ ନେଇଥାଏ । α ର ମୂଲ୍ୟ _____ ଅଟେ ।

Response Type : Numeric

Evaluation Required For SA : Yes

Show Word Count : Yes

Answers Type : Range

Text Areas : PlainText

Possible Answers :

5 to 5.001

Question Number : 23 Question Id : 70819121836 Question Type : SA

Correct Marks : 4 Wrong Marks : 0

The volume V of a given mass of monoatomic gas changes with temperature T according to

the relation $V = KT^{\frac{2}{3}}$. The workdone when temperature changes by 90 K will be xR . The value of x is _____.

[R = universal gas constant]

Response Type : Numeric

Evaluation Required For SA : Yes

Show Word Count : Yes

Answers Type : Range

Text Areas : PlainText

Possible Answers :

5 to 5.001

Question Number : 23 Question Id : 70819121836 Question Type : SA

Correct Marks : 4 Wrong Marks : 0

ନିର୍ଦ୍ଦିଷ୍ଟ ବସ୍ତୁରୁ ବିଶିଷ୍ଟ ଗୋଟିଏ ଏକପରମାଣୁକ ଗ୍ୟାସର ଆୟତନ (V) ତାପମାତ୍ରା (T) ସହ $V = KT^{\frac{2}{3}}$ ସମ୍ପର୍କ ଅନୁସାରେ ପରିବର୍ତ୍ତନ ହୋଇଥାଏ । ଯେତେବେଳେ ତାପମାତ୍ରା 90 K ପରିମାଣର ପରିବର୍ତ୍ତନ ହୋଇଥାଏ, କାର୍ଯ୍ୟସମ୍ପାଦନ ହେବ xR । x ର ମୂଲ୍ୟ _____ ଅଟେ । (R = ସାର୍ବତ୍ରିକ ଗ୍ୟାସ୍ ଧ୍ରୁବାଙ୍କ)

Response Type : Numeric

Evaluation Required For SA : Yes

Show Word Count : Yes

Answers Type : Range

Text Areas : PlainText

Possible Answers :

5 to 5.001

Question Number : 24 Question Id : 70819121837 Question Type : SA

Correct Marks : 4 Wrong Marks : 0

Two stream of photons, possessing energies equal to twice and ten times the work function of metal are incident on the metal surface successively. The value of ratio of maximum velocities of the photoelectrons emitted in the two respective cases is $x : y$. The value of x is _____.

Response Type : Numeric

Evaluation Required For SA : Yes

Show Word Count : Yes

Answers Type : Range

Text Areas : PlainText

Possible Answers :

5 to 5.001

Question Number : 24 Question Id : 70819121837 Question Type : SA

Correct Marks : 4 Wrong Marks : 0

ଧାତୁଚିତ୍ର କାର୍ଯ୍ୟଫଳନର ଦୁଇଗୁଣ ଏବଂ ଦଶଗୁଣ ଶକ୍ତି ଥିବା ଦୁଇଟି ଫୋଟନ୍ ସ୍ରୋତ କ୍ରମାଗତ ଭାବରେ ଧାତବ ପୃଷ୍ଠରେ ଆପତ୍ତିତ ହେଉଛନ୍ତି । ଦୁଇଟି ପରସ୍ପର କ୍ଷେତ୍ରରେ ଉତ୍ସର୍ଜନ ହେଉଥିବା ଫଟୋ-ଇଲେକ୍ଟ୍ରନ୍ ଗୁଡ଼ିକର ସର୍ବାଧିକ ବେଗର ଅନୁପାତର ମୂଲ୍ୟ ଯଥାକ୍ରମେ ଅଟେ $x : y$ । x ର ମୂଲ୍ୟ _____ ।

Response Type : Numeric

Evaluation Required For SA : Yes

Show Word Count : Yes

Answers Type : Range

Text Areas : PlainText

Possible Answers :

5 to 5.001

Question Number : 25 Question Id : 70819121838 Question Type : SA

Correct Marks : 4 Wrong Marks : 0

If the highest frequency modulating a carrier is 5 kHz, then the number of AM broadcast stations accommodated in a 90 kHz bandwidth are _____.

Response Type : Numeric

Evaluation Required For SA : Yes

Show Word Count : Yes

Answers Type : Range

Text Areas : PlainText

Possible Answers :

5 to 5.001

Question Number : 25 Question Id : 70819121838 Question Type : SA

Correct Marks : 4 Wrong Marks : 0

ଯଦି ଗୋଟିଏ ବାହକ ତରଙ୍ଗକୁ ମଡୁଲନ୍ ପାଇଁ ସର୍ବାଧିକ ଆବୃତ୍ତି 5 kHz ଅଟେ, ତେବେ ଗୋଟିଏ 90 kHz ବ୍ୟାଣ୍ଡପ୍ରସ୍ଥ ମଧ୍ୟରେ ଜାଗା ହୋଇପାରୁଥିବା ଅସ୍ଥାୟୀ ମଡୁଲନ୍ (ଏ.ଏମ୍) ବ୍ରଡକାଷ୍ଟ କେନ୍ଦ୍ରର ସଂଖ୍ୟା ହେଉଛି _____ ।

Response Type : Numeric

Evaluation Required For SA : Yes

Show Word Count : Yes

Answers Type : Range

Text Areas : PlainText

Possible Answers :

5 to 5.001

Question Number : 26 Question Id : 70819121839 Question Type : SA

Correct Marks : 4 Wrong Marks : 0

In the reported figure of earth, the value of acceleration due to gravity is same at point A and C but it is smaller than that of its value at point B (surface of the earth). The value of OA : AB will be $x : y$. The value of x is _____.

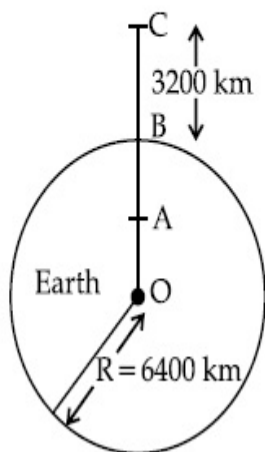

Response Type : Numeric

Evaluation Required For SA : Yes

Show Word Count : Yes

Answers Type : Range

Text Areas : PlainText

Possible Answers :

5 to 5.001

Question Number : 26 **Question Id :** 70819121839 **Question Type :** SA

Correct Marks : 4 **Wrong Marks :** 0

ବର୍ଣ୍ଣିତ ପୃଥିବୀର ଚିତ୍ରରେ, ମାଧ୍ୟାକର୍ଷଣଜନିତ ତ୍ୱରଣର ମୂଲ୍ୟ A ଓ C ବିନ୍ଦୁରେ ସମାନ ଅଟେ । କିନ୍ତୁ ଏହା B ବିନ୍ଦୁ (ପୃଥିବୀ ପୃଷ୍ଠ)ରେ ଥିବା ଏହି ମୂଲ୍ୟଠାରୁ ସାନ । OA : AB ର ମୂଲ୍ୟ ହେବ $x : y$ । x ର ମୂଲ୍ୟ ହେବ _____ ।

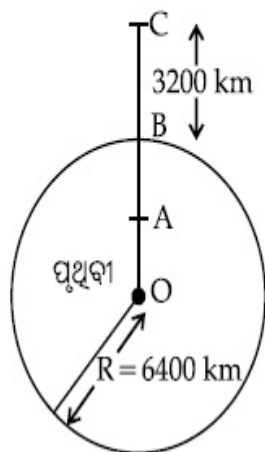

Response Type : Numeric

Evaluation Required For SA : Yes

Show Word Count : Yes

Answers Type : Range

Text Areas : PlainText

Possible Answers :

5 to 5.001

Question Number : 27 Question Id : 70819121840 Question Type : SA

Correct Marks : 4 Wrong Marks : 0

1 mole of rigid diatomic gas performs a work of $\frac{Q}{5}$ when heat Q is supplied to it. The molar heat capacity of the gas during this transformation is $\frac{xR}{8}$. The value of x is _____.

[R = universal gas constant]

Response Type : Numeric

Evaluation Required For SA : Yes

Show Word Count : Yes

Answers Type : Range

Text Areas : PlainText

Possible Answers :

5 to 5.001

Question Number : 27 Question Id : 70819121840 Question Type : SA

Correct Marks : 4 Wrong Marks : 0

ଗୋଟିଏ ଦୃଢ଼ ଦ୍ଵିପରମାଣୁକ 1 ମୋଲର ଗ୍ୟାସ୍ $\frac{Q}{5}$ ପରିମାଣ କାର୍ଯ୍ୟ ସମ୍ପାଦନ କରିଥାଏ ଯେତେବେଳେ ଏହାକୁ Q ପରିମାଣର ତାପ ଯୋଗାଯାଏ । ଏହି ପରିବର୍ତ୍ତନ ସମୟରେ ଗ୍ୟାସ୍‌ଟିର ମୋଲାର ତାପଧାରିତା ହେଉଛି $\frac{xR}{8}$ । x ର ମୂଲ୍ୟ _____ ଅଟେ । (R = ସାର୍ବତ୍ରିକ ଗ୍ୟାସ୍ ଧ୍ରୁବଙ୍କ)

Response Type : Numeric

Evaluation Required For SA : Yes

Show Word Count : Yes

Answers Type : Range

Text Areas : PlainText

Possible Answers :

5 to 5.001

Question Number : 28 **Question Id :** 70819121841 **Question Type :** SA

Correct Marks : 4 **Wrong Marks :** 0

A point source of light S , placed at a distance 60 cm in front of the centre of a plane mirror of width 50 cm, hangs vertically on a wall. A man walks in front of the mirror along a line parallel to the mirror at a distance 1.2 m from it (see in the figure). The distance between the extreme points where he can see the image of the light source in the mirror is _____ cm.

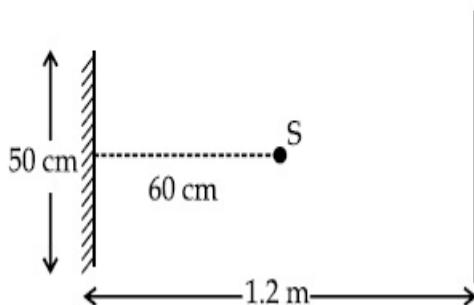

Response Type : Numeric

Evaluation Required For SA : Yes

Show Word Count : Yes

Answers Type : Range

Text Areas : PlainText

Possible Answers :

5 to 5.001

Question Number : 28 **Question Id :** 70819121841 **Question Type :** SA

Correct Marks : 4 **Wrong Marks :** 0

ଗୋଟିଏ କାନ୍ଥରେ ଭୂଲମ୍ବୀୟ ଭାବେ ଟଙ୍ଗାଯାଇଥିବା ଗୋଟିଏ ସମତଳ ଦର୍ପଣର କେନ୍ଦ୍ର ଠାରୁ 60 cm ଦୂରତାରେ ଆଲୋକର ଏକ ବିନ୍ଦୁ ଉପ୍ପ S ରଖାଯାଇଛି । ଜଣେ ଲୋକ ଦର୍ପଣ ସାମନାରେ 1.2 m ଦୂରତାରେ ଦର୍ପଣ ସହ ସମାନ୍ତର ଥିବା ଏକ ରେଖା ଦିଗରେ ଚାଲୁଅଛି (ଚିତ୍ରଦେଖ) । ଶେଷବର୍ତ୍ତୀ ଦୁଇଟି ବିନ୍ଦୁ ମଧ୍ୟରେ ଦୂରତା ଯେଉଁଠାରେ ସିଏ ଦର୍ପଣରେ ଆଲୋକ ଉତ୍ତର ପ୍ରତିବିମ୍ବକୁ ଦେଖିପାରୁଥିବ, ସେହି ଦୂରତା ହେଉଛି _____ ସେଣ୍ଟିମିଟର ।

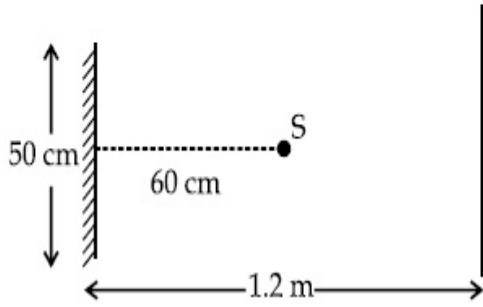

Response Type : Numeric

Evaluation Required For SA : Yes

Show Word Count : Yes

Answers Type : Range

Text Areas : PlainText

Possible Answers :

5 to 5.001

Question Number : 29 **Question Id :** 70819121842 **Question Type :** SA

Correct Marks : 4 **Wrong Marks :** 0

A particle executes S.H.M. with amplitude 'a' and time period 'T'. The displacement of the particle when its speed is half of maximum speed is $\frac{\sqrt{x}a}{2}$. The value of x is _____.

Response Type : Numeric

Evaluation Required For SA : Yes

Show Word Count : Yes

Answers Type : Range

Text Areas : PlainText

Possible Answers :

5 to 5.001

Question Number : 29 **Question Id :** 70819121842 **Question Type :** SA

Correct Marks : 4 Wrong Marks : 0

ଆକାଶ 'a' ଏବଂ ଆବର୍ତ୍ତକାଳ 'T' ସହ ଗୋଟିଏ କଣିକା ସରଳ ହାରମୋନିକ୍ ଗତି ସମ୍ପାଦନ କରୁଅଛି । ଯେତେବେଳେ ଏହାର ବେଗଟି ସର୍ବାଧିକ ବେଗର ଅଧା ହୋଇଥିବ, କଣିକାଟିର ବିସ୍ଥାପନ ହେଉଛି : $\frac{\sqrt{x}a}{2}$ । x ର ମୂଲ୍ୟ ଅଟେ _____ ।

Response Type : Numeric

Evaluation Required For SA : Yes

Show Word Count : Yes

Answers Type : Range

Text Areas : PlainText

Possible Answers :

5 to 5.001

Question Number : 30 Question Id : 70819121843 Question Type : SA

Correct Marks : 4 Wrong Marks : 0

27 similar drops of mercury are maintained at 10 V each. All these spherical drops combine into a single big drop. The potential energy of the bigger drop is _____ times that of a smaller drop.

Response Type : Numeric

Evaluation Required For SA : Yes

Show Word Count : Yes

Answers Type : Range

Text Areas : PlainText

Possible Answers :

5 to 5.001

Question Number : 30 Question Id : 70819121843 Question Type : SA

Correct Marks : 4 Wrong Marks : 0

ଏକାଞ୍ଚଳି 27 ଟି ପାରଦ ଗୋପାଗୁଡ଼ିକୁ ପ୍ରତ୍ୟେକ 10 V ରେ ଚାଲୁ ରଖାଯାଇଛି । ଏହିସବୁ ଛୋଟ ଗୋଲାକାର ଗୋପାଗୁଡ଼ିକୁ ମିଶାଇ ଏକ ବଡ଼ ଗୋପା କରାଗଲା । ବଡ଼ ଗୋପାଟିର ବିଭବ ଶକ୍ତି ଗୋଟିଏ ଛୋଟ ଗୋପାର _____ ଗୁଣ ହେବ ।

Response Type : Numeric

Evaluation Required For SA : Yes

Show Word Count : Yes

Answers Type : Range

Text Areas : PlainText

Possible Answers :

5 to 5.001

Chemistry Section A

Section Id :	708191996
Section Number :	3
Section type :	Online
Mandatory or Optional :	Mandatory
Number of Questions :	20
Number of Questions to be attempted :	20
Section Marks :	80
Mark As Answered Required? :	Yes
Sub-Section Number :	1
Sub-Section Id :	7081911276
Question Shuffling Allowed :	Yes

Question Number : 31 Question Id : 70819121844 Question Type : MCQ Option Shuffling : Yes

Is Question Mandatory : No

Correct Marks : 4 Wrong Marks : 1

Match List-I with List-II.

List-I (Molecule)	List-II (Bond order)
(a) Ne ₂	(i) 1
(b) N ₂	(ii) 2
(c) F ₂	(iii) 0
(d) O ₂	(iv) 3

Choose the correct answer from the options given below :

Options :

70819170681. (a) → (i), (b) → (ii), (c) → (iii), (d) → (iv)

70819170682. (a) → (iv), (b) → (iii), (c) → (ii), (d) → (i)

70819170683. (a) → (ii), (b) → (i), (c) → (iv), (d) → (iii)

70819170684. (a) → (iii), (b) → (iv), (c) → (i), (d) → (ii)

Question Number : 31 Question Id : 70819121844 Question Type : MCQ Option Shuffling : Yes

Is Question Mandatory : No

Correct Marks : 4 Wrong Marks : 1

ତାଲିକା - I କୁ ତାଲିକା - II ସହିତ ମିଳାଅ ।

ତାଲିକା - I (ଅଣୁ)	ତାଲିକା - II (ବନ୍ଧକ୍ରମ)
(a) Ne ₂	(i) 1
(b) N ₂	(ii) 2
(c) F ₂	(iii) 0
(d) O ₂	(iv) 3

ନିମ୍ନ ବିକଳ୍ପରୁ ସଠିକ୍ ଉତ୍ତରଟି ବାଛି :

Options :

70819170681. (a) → (i), (b) → (ii), (c) → (iii), (d) → (iv)

70819170682. (a) → (iv), (b) → (iii), (c) → (ii), (d) → (i)

70819170683. (a) → (ii), (b) → (i), (c) → (iv), (d) → (iii)

70819170684. (a) → (iii), (b) → (iv), (c) → (i), (d) → (ii)

Question Number : 32 Question Id : 70819121845 Question Type : MCQ Option Shuffling : Yes

Is Question Mandatory : No

Correct Marks : 4 Wrong Marks : 1

The nature of charge on resulting colloidal particles when FeCl_3 is added to excess of hot water is :

Options :

70819170685. positive

70819170686. negative

70819170687. neutral

70819170688. sometimes positive and sometimes negative

Question Number : 32 Question Id : 70819121845 Question Type : MCQ Option Shuffling : Yes

Is Question Mandatory : No

Correct Marks : 4 Wrong Marks : 1

ଅଧିକା FeCl_3 କୁ ଗରମ ପାଣିରେ ମିଶାଇଲେ ପରିଣାମ ସ୍ୱରୂପ ମିଳୁଥିବା କଳିକ କଣ (ପାର୍ଟିକଲ)ର ଚାର୍ଜର ଗୁଣ ହେଉଛି :

Options :

70819170685. ପଜିଟିଭ୍

70819170686. ନେଗେଟିଭ୍

70819170687. ନିଉଟ୍ରାଲ୍

70819170688. ବେଳେବେଳେ ପଜିଟିଭ୍ ଏବଂ ବେଳେବେଳେ ନେଗେଟିଭ୍

Question Number : 33 Question Id : 70819121846 Question Type : MCQ Option Shuffling : Yes

Is Question Mandatory : No

Correct Marks : 4 Wrong Marks : 1

The correct order of electron gain enthalpy is :

Options :

70819170689. $O > S > Se > Te$

70819170690. $Te > Se > S > O$

70819170691. $S > O > Se > Te$

70819170692. $S > Se > Te > O$

Question Number : 33 Question Id : 70819121846 Question Type : MCQ Option Shuffling : Yes

Is Question Mandatory : No

Correct Marks : 4 Wrong Marks : 1

ଇଲେକ୍ଟ୍ରନ୍ ଗେନ୍ ଏକ୍ସଲ୍ୟାଲପିର ସଠିକ୍ କ୍ରମଟି ହେଉଛି :

Options :

70819170689. $O > S > Se > Te$

70819170690. $Te > Se > S > O$

70819170691. $S > O > Se > Te$

70819170692. $S > Se > Te > O$

Question Number : 34 Question Id : 70819121847 Question Type : MCQ Option Shuffling : Yes

Is Question Mandatory : No

Correct Marks : 4 Wrong Marks : 1

Match List-I with List-II.

List-I	List-II
(a) Siderite	(i) Cu
(b) Calamine	(ii) Ca
(c) Malachite	(iii) Fe
(d) Cryolite	(iv) Al
	(v) Zn

Choose the correct answer from the options given below :

Options :

70819170693. (a) → (i), (b) → (ii), (c) → (v), (d) → (iii)

70819170694. (a) → (iii), (b) → (v), (c) → (i), (d) → (iv)

70819170695. (a) → (i), (b) → (ii), (c) → (iii), (d) → (iv)

70819170696. (a) → (iii), (b) → (i), (c) → (v), (d) → (ii)

Question Number : 34 Question Id : 70819121847 Question Type : MCQ Option Shuffling : Yes

Is Question Mandatory : No

Correct Marks : 4 Wrong Marks : 1

ତାଲିକା I କୁ ତାଲିକା II ସହିତ ମିଳାଅ ।

ତାଲିକା - I	ତାଲିକା - II
(a) ସିଡେରାଇଟ୍	(i) Cu
(b) କାଲମାଇନ	(ii) Ca
(c) ମାଲାକାଇଟ୍	(iii) Fe
(d) କ୍ରୀଓଲାଇଟ୍	(iv) Al
	(v) Zn

ନିମ୍ନ ବିକଳ୍ପ ମଧ୍ୟରୁ ଠିକ୍ ଉତ୍ତରକୁ ବାଛ ।

Options :

70819170693. (a) → (i), (b) → (ii), (c) → (v), (d) → (iii)

70819170694. (a) → (iii), (b) → (v), (c) → (i), (d) → (iv)

70819170695. (a) → (i), (b) → (ii), (c) → (iii), (d) → (iv)

70819170696. (a) → (iii), (b) → (i), (c) → (v), (d) → (ii)

Question Number : 35 Question Id : 70819121848 Question Type : MCQ Option Shuffling : Yes

Is Question Mandatory : No

Correct Marks : 4 Wrong Marks : 1

Which of the following forms of hydrogen emits low energy β^- particles ?

Options :

70819170697. Proton H^+

70819170698. Protium ${}_1^1H$

70819170699. Deuterium ${}_1^2H$

70819170700. Tritium ${}_1^3H$

Question Number : 35 Question Id : 70819121848 Question Type : MCQ Option Shuffling : Yes

Is Question Mandatory : No

Correct Marks : 4 Wrong Marks : 1

ନିମ୍ନରେ ଥିବା ହାଇଡ୍ରୋଜେନ୍‌ର କେଉଁ ଆକୃତି (ଫର୍ମ)ଟି ଅଳ୍ପ ଶକ୍ତି ଥିବା β^- କଣ (ପାର୍ଟିକଲ) ଉତ୍ସର୍ଜନ କରେ ?

Options :

70819170697. ପ୍ରୋଟୋନ୍ H^+

70819170698. ପ୍ରୋଟିୟମ୍ ${}_1^1H$

70819170699.

ଡିଉଟେରିୟମ୍ ${}^2_1\text{H}$

70819170700. ଟ୍ରିଟିୟମ୍ ${}^3_1\text{H}$

Question Number : 36 Question Id : 70819121849 Question Type : MCQ Option Shuffling : Yes

Is Question Mandatory : No

Correct Marks : 4 Wrong Marks : 1

Match List-I with List-II.

List-I	List-II
(a) Sodium Carbonate	(i) Deacon
(b) Titanium	(ii) Castner-Kellner
(c) Chlorine	(iii) van-Arkel
(d) Sodium hydroxide	(iv) Solvay

Choose the correct answer from the options given below :

Options :

70819170701. (a) → (iv), (b) → (iii), (c) → (i), (d) → (ii)

70819170702. (a) → (iv), (b) → (i), (c) → (ii), (d) → (iii)

70819170703. (a) → (i), (b) → (iii), (c) → (iv), (d) → (ii)

70819170704. (a) → (iii), (b) → (ii), (c) → (i), (d) → (iv)

Question Number : 36 Question Id : 70819121849 Question Type : MCQ Option Shuffling : Yes

Is Question Mandatory : No

Correct Marks : 4 Wrong Marks : 1

ତାଲିକା - I କୁ ତାଲିକା - II ସହିତ ମିଳାଅ ।

ତାଲିକା - I

ତାଲିକା - II

- | | |
|-----------------------------|-----------------------|
| (a) ସୋଡ଼ିୟମ୍ କାର୍ବୋନେଟ୍ | (i) ଡେକ୍ସନ୍ |
| (b) ଟାଲଟାଲିୟମ୍ | (ii) କାର୍ବନ୍ - କେଲ୍ସର |
| (c) କ୍ଲୋରିନ୍ | (iii) ଭିନ୍-ଆକ୍ସେଲ୍ |
| (d) ସୋଡ଼ିୟମ୍ ହାଇଡ୍ରୋକ୍ସାଇଡ୍ | (iv) ସଲ୍ଫେଟ୍ |

ନିମ୍ନ ବିକଳ୍ପ ମଧ୍ୟରୁ ଠିକ୍ ଉତ୍ତରଟି ବାଛି ।

Options :

70819170701. (a) → (iv), (b) → (iii), (c) → (i), (d) → (ii)

70819170702. (a) → (iv), (b) → (i), (c) → (ii), (d) → (iii)

70819170703. (a) → (i), (b) → (iii), (c) → (iv), (d) → (ii)

70819170704. (a) → (iii), (b) → (ii), (c) → (i), (d) → (iv)

Question Number : 37 Question Id : 70819121850 Question Type : MCQ Option Shuffling : Yes

Is Question Mandatory : No

Correct Marks : 4 Wrong Marks : 1

Which pair of oxides is acidic in nature ?

Options :

70819170705. B_2O_3, SiO_2

70819170706. B_2O_3, CaO

70819170707. N_2O, BaO

70819170708. CaO, SiO_2

Question Number : 37 Question Id : 70819121850 Question Type : MCQ Option Shuffling : Yes

Is Question Mandatory : No

Correct Marks : 4 Wrong Marks : 1

କେଉଁ ଅକ୍ସାଇଡ୍ ଯୋଡ଼ାଟି ଅମ୍ଳୀୟ ଗୁଣର ଅଟେ ?

Options :

70819170705. B_2O_3, SiO_2

70819170706. B_2O_3, CaO

70819170707. N_2O, BaO

70819170708. CaO, SiO_2

Question Number : 38 Question Id : 70819121851 Question Type : MCQ Option Shuffling : Yes

Is Question Mandatory : No

Correct Marks : 4 Wrong Marks : 1

Given below are two statements : one is labelled as Assertion A and the other is labelled as Reason R.

Assertion A : In TlI_3 , isomorphous to CsI_3 , the metal is present in +1 oxidation state.

Reason R : Tl metal has fourteen f electrons in its electronic configuration.

In the light of the above statements, choose the most appropriate answer from the options given below :

Options :

70819170709. Both A and R are correct and R is the correct explanation of A

70819170710. Both A and R are correct but R is NOT the correct explanation of A

70819170711. A is correct but R is not correct

70819170712. A is not correct but R is correct

Question Number : 38 Question Id : 70819121851 Question Type : MCQ Option Shuffling : Yes
Is Question Mandatory : No

Correct Marks : 4 Wrong Marks : 1

ନିମ୍ନରେ ଦୁଇଟି ଉକ୍ତି ଦିଆଯାଇଛି । ଗୋଟିଏ ଘୋଷଣା **A** ଏବଂ ଅନ୍ୟଟି କାରଣ **R** ।

ଘୋଷଣା- **A** : TlH_3 ରେ ଧାତୁଟି +1 କାରଣ ଅବସ୍ଥାରେ ଅଛି ।

କାରଣ- **R** : Tl ଧାତୁର ଇଲେକ୍ଟ୍ରୋନିକ ବିନ୍ୟାସରେ 14 ଟି f ଇଲେକ୍ଟ୍ରନ୍ ଅଛି ।

ଉପର ଉକ୍ତି ଭିତ୍ତିରେ, ନିମ୍ନ ବିକଳ୍ପ ମଧ୍ୟରୁ ସବୁଠାରୁ ଉପଯୁକ୍ତ ଉତ୍ତରଟି ବାଛି ।

Options :

70819170709. ଉଭୟ **A** ଏବଂ **R** ଠିକ୍ ଏବଂ **R** ହେଉଛି **A** ର ସଠିକ୍ ବ୍ୟାଖ୍ୟା ।

70819170710. ଉଭୟ **A** ଏବଂ **R** ଠିକ୍ କିନ୍ତୁ **R**, **A**ର ସଠିକ୍ ବ୍ୟାଖ୍ୟା ନୁହେଁ ।

70819170711. **A** ଠିକ୍ କିନ୍ତୁ **R** ଭୁଲ୍ ।

70819170712. **A** ଭୁଲ୍ କିନ୍ତୁ **R** ଠିକ୍ ।

Question Number : 39 Question Id : 70819121852 Question Type : MCQ Option Shuffling : Yes
Is Question Mandatory : No

Correct Marks : 4 Wrong Marks : 1

Calgon is used for water treatment. Which of the following statement is NOT true about Calgon ?

Options :

70819170713. Calgon contains the 2nd most abundant element by weight in the Earth's crust.

70819170714. It is polymeric compound and is water soluble.

70819170715. It is also known as Graham's salt.

70819170716. It doesnot remove Ca^{2+} ion by precipitation.

**Question Number : 39 Question Id : 70819121852 Question Type : MCQ Option Shuffling : Yes
Is Question Mandatory : No**

Correct Marks : 4 Wrong Marks : 1

କାଲଗନ ଜଳ ପରିଶୋଧନ ପାଇଁ ବ୍ୟବହାର କରାଯାଏ । ନିମ୍ନ ଉଦ୍ଭିଗୁଡ଼ିକ ମଧ୍ୟରୁ କେଉଁଟି କାଲଗନ ବିଷୟରେ ଠିକ୍ ନୁହେଁ ?

Options :

70819170713. କାଲଗନ ଭୂପୃଷ୍ଠର ବାହ୍ୟଭାଗରେ ବସ୍ତୁର ଭିତ୍ତିରେ (By mass) ବହୁଳ ଭାବରେ ମିଳୁଥିବା ଦ୍ୱିତୀୟ ମୌଳିକକୁ ଧାରଣ କରିଥାଏ ।

70819170714. ଏହା ଏକ ବହୁଳାକରଣ ଯୌଗିକ ଏବଂ ଜଳରେ ଦ୍ରବଣୀୟ ।

70819170715. ଏହା ଗ୍ରାହାତ୍ମକ ଲୁଣ ହିସାବରେ ପରିଚିତ ।

70819170716. ଏହା Ca^{2+} କୁ ଅବକ୍ଷେପଣ ଦ୍ୱାରା ବାହାର କରିବ ନାହିଁ ।

**Question Number : 40 Question Id : 70819121853 Question Type : MCQ Option Shuffling : Yes
Is Question Mandatory : No**

Correct Marks : 4 Wrong Marks : 1

Ceric ammonium nitrate and $\text{CHCl}_3/\text{alc. KOH}$ are used for the identification of functional groups present in _____ and _____ respectively.

Options :

70819170717. alcohol, amine

70819170718. amine, alcohol

70819170719. alcohol, phenol

70819170720. amine, phenol

Question Number : 40 Question Id : 70819121853 Question Type : MCQ Option Shuffling : Yes

Is Question Mandatory : No

Correct Marks : 4 Wrong Marks : 1

ସେରିକ୍ ଏମୋନିୟମ୍ ନାଇଟ୍ରେଟ୍ ଏବଂ $\text{CHCl}_3/\text{alc. KOH}$ ଯଥାକ୍ରମେ _____ ଏବଂ _____ ରେ ଥିବା କ୍ରିୟାତ୍ମକ ମୂଳକକୁ ଚିହ୍ନଟ କରିବା ପାଇଁ ବ୍ୟବହାର କରାଯାଏ ।

Options :

70819170717. ଆଲକୋହଲ୍, ଆମିନ୍

70819170718. ଆମିନ୍, ଆଲକୋହଲ୍

70819170719. ଆଲକୋହଲ୍, ଫେନଲ୍

70819170720. ଆମିନ୍, ଫେନଲ୍

Question Number : 41 Question Id : 70819121854 Question Type : MCQ Option Shuffling : Yes

Is Question Mandatory : No

Correct Marks : 4 Wrong Marks : 1

In $\overset{1}{\text{CH}_2}=\overset{2}{\text{C}}=\overset{3}{\text{CH}}-\overset{4}{\text{CH}_3}$ molecule, the hybridization of carbon 1, 2, 3 and 4 respectively, are :

Options :

70819170721. sp^2, sp^2, sp^2, sp^3

70819170722. sp^3, sp, sp^3, sp^3

70819170723. sp^2, sp, sp^2, sp^3

70819170724. sp^2, sp^3, sp^2, sp^3

Question Number : 41 Question Id : 70819121854 Question Type : MCQ Option Shuffling : Yes

Is Question Mandatory : No

Correct Marks : 4 Wrong Marks : 1

$\overset{1}{\text{CH}_2} = \overset{2}{\text{C}} = \overset{3}{\text{CH}} - \overset{4}{\text{CH}_3}$ ଅଣୁରେ କାରବନ୍ 1, 2, 3 ଏବଂ 4 ର ସଂକରଣ ଯଥାକ୍ରମେ, ହେଉଛି :

Options :

70819170721. sp^2, sp^2, sp^2, sp^3

70819170722. sp^3, sp, sp^3, sp^3

70819170723. sp^2, sp, sp^2, sp^3

70819170724. sp^2, sp^3, sp^2, sp^3

Question Number : 42 Question Id : 70819121855 Question Type : MCQ Option Shuffling : Yes

Is Question Mandatory : No

Correct Marks : 4 Wrong Marks : 1

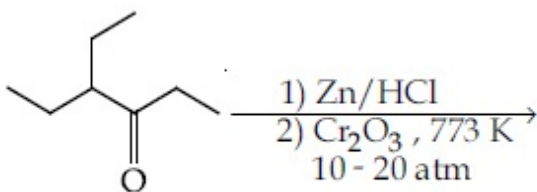

Considering the above reaction, the major product among the following is :

Options :

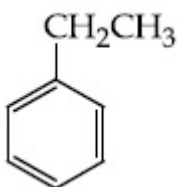

70819170725.

70819170726.

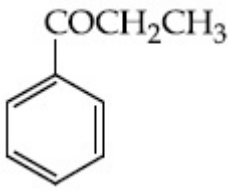

70819170727.

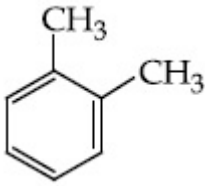

70819170728.

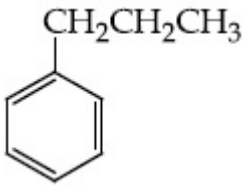

Question Number : 42 Question Id : 70819121855 Question Type : MCQ Option Shuffling : Yes

Is Question Mandatory : No

Correct Marks : 4 Wrong Marks : 1

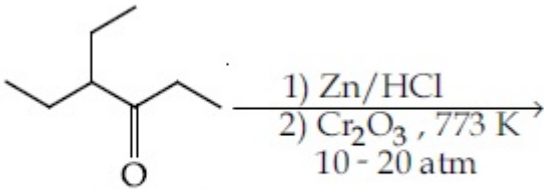

ଉପର ପ୍ରତିକ୍ରିୟାକୁ ବିଚାରକୁ ନେଇ ମୁଖ୍ୟ ଉତ୍ପାଦ ନିମ୍ନଲିଖିତ ମଧ୍ୟରୁ ହେଉଛି :

Options :

70819170725.

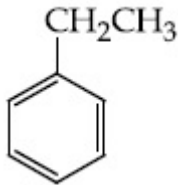

70819170726.

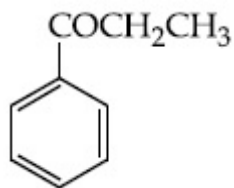

70819170727.

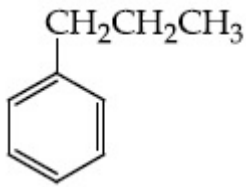
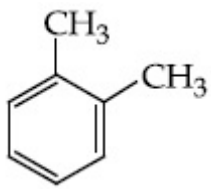

70819170728.

Question Number : 43 Question Id : 70819121856 Question Type : MCQ Option Shuffling : Yes

Is Question Mandatory : No

Correct Marks : 4 Wrong Marks : 1

Identify A in the given reaction.

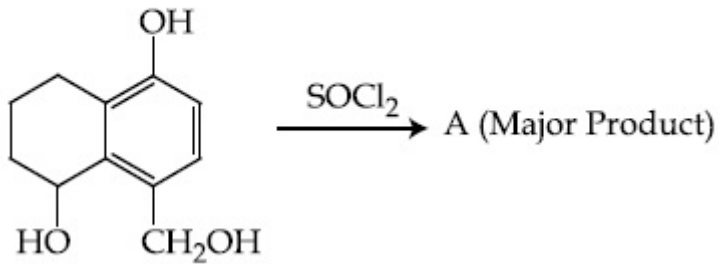

Options :

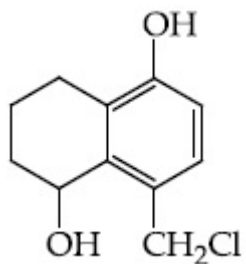

70819170729.

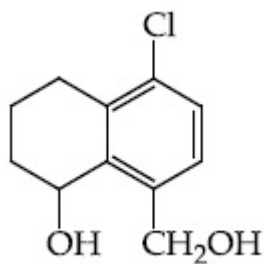

70819170730.

70819170731.

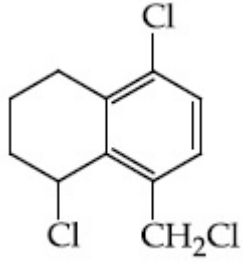
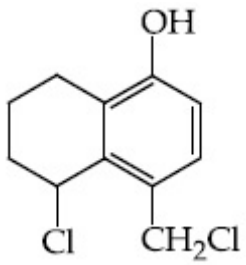

70819170732.

Question Number : 43 Question Id : 70819121856 Question Type : MCQ Option Shuffling : Yes
Is Question Mandatory : No

Correct Marks : 4 Wrong Marks : 1

ଦିଆଯାଇଥିବା ପ୍ରତିକ୍ରିୟାଟିରେ A କୁ ଚିହ୍ନଟ କର ।

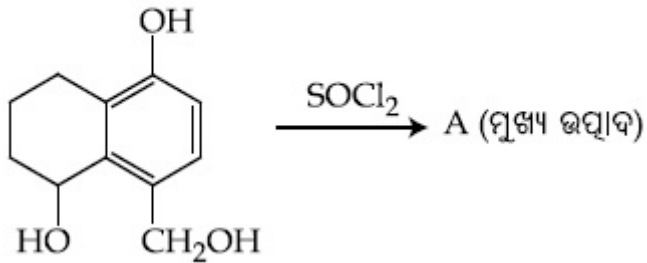

Options :

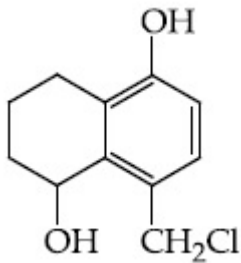

70819170729.

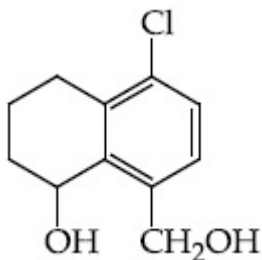

70819170730.

70819170731.

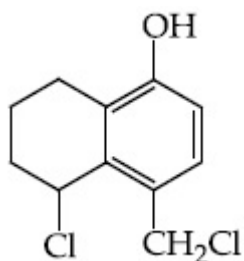

70819170732.

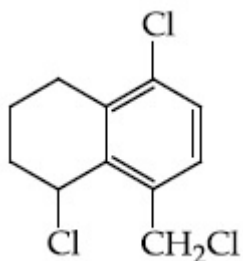

Question Number : 44 Question Id : 70819121857 Question Type : MCQ Option Shuffling : Yes Is Question Mandatory : No

Correct Marks : 4 Wrong Marks : 1

Identify A in the given chemical reaction.

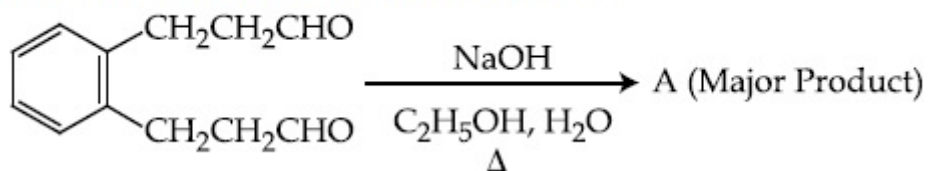

Options :

70819170733.

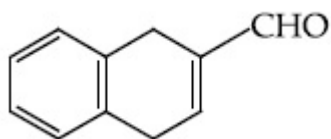

70819170734.

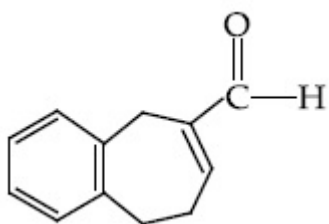

70819170735.

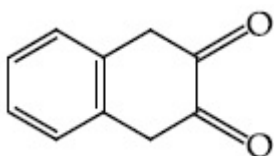

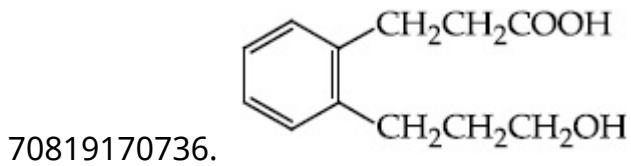

Question Number : 44 Question Id : 70819121857 Question Type : MCQ Option Shuffling : Yes
Is Question Mandatory : No

Correct Marks : 4 Wrong Marks : 1

ଦିଆଯାଇଥିବା ରାସାୟନିକ ପ୍ରତିକ୍ରିୟାଟିରେ A କୁ ଚିହ୍ନଟ କର ।

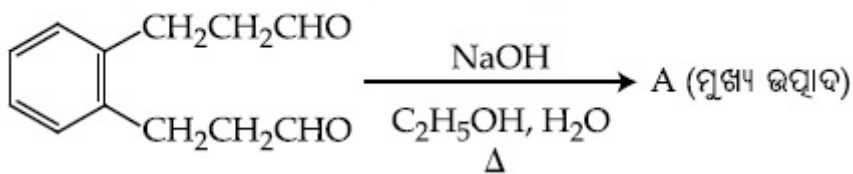

Options :

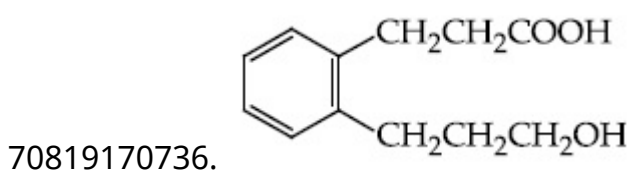
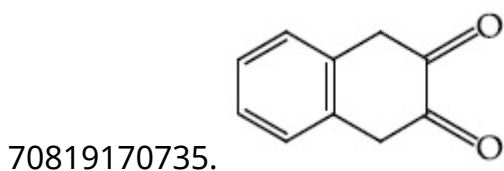
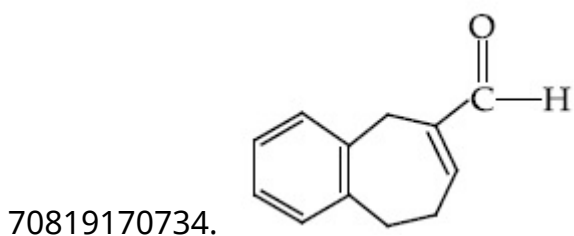
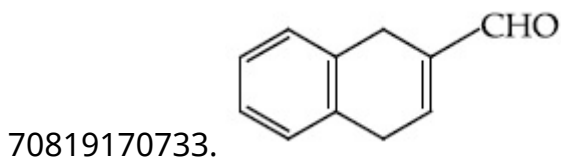

Question Number : 45 Question Id : 70819121858 Question Type : MCQ Option Shuffling : Yes

Is Question Mandatory : No

Correct Marks : 4 Wrong Marks : 1

Identify A in the following chemical reaction.

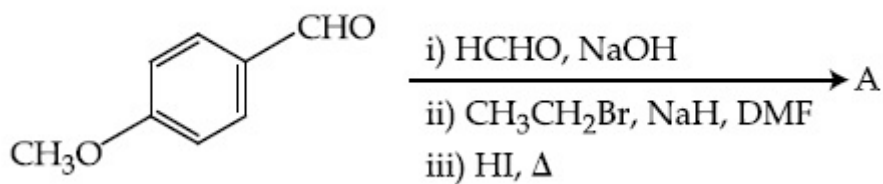

Options :

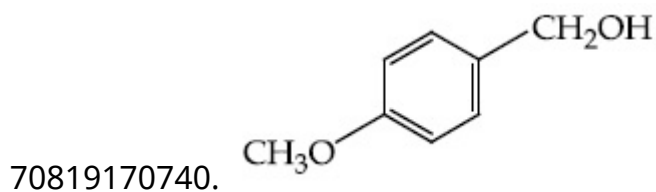
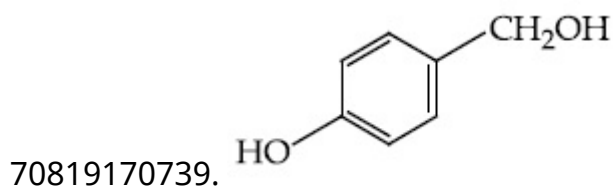
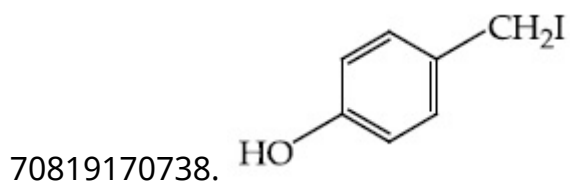
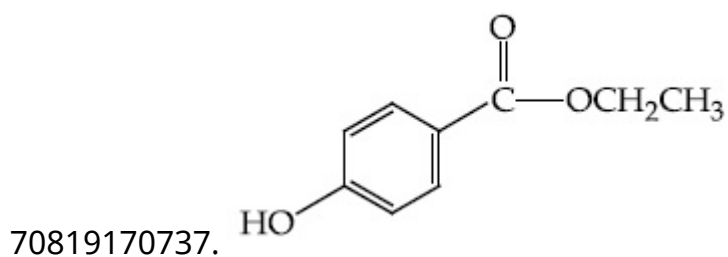

Question Number : 45 Question Id : 70819121858 Question Type : MCQ Option Shuffling : Yes

Is Question Mandatory : No

Correct Marks : 4 Wrong Marks : 1

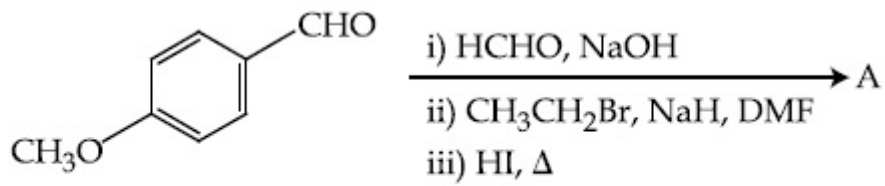

ଉପର ରାସାୟନିକ ପ୍ରତିକ୍ରିୟାରେ A କୁ ଚିହ୍ନଟ କର ।

Options :

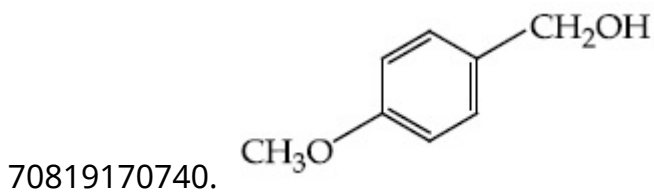
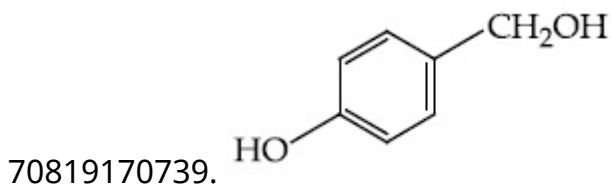
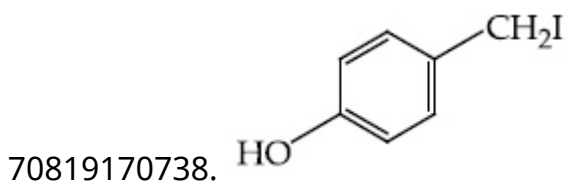
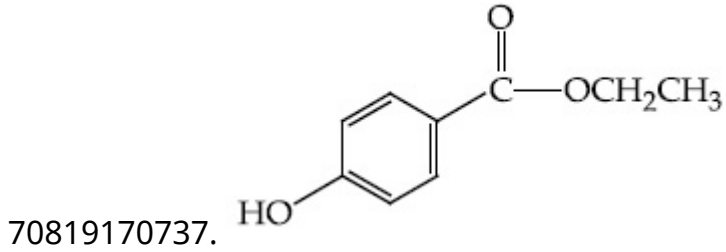

Question Number : 46 Question Id : 70819121859 Question Type : MCQ Option Shuffling : Yes

Is Question Mandatory : No

Correct Marks : 4 Wrong Marks : 1

Match List-I with List-II.

List-I

List-II

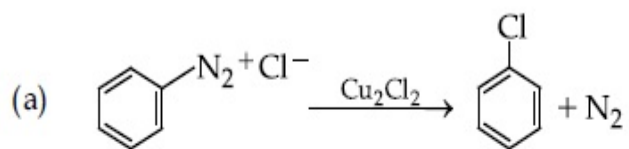

(i) Wurtz reaction

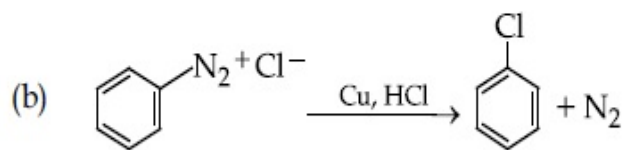

(ii) Sandmeyer reaction

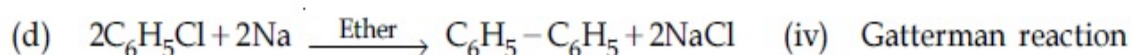
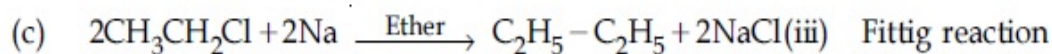

Choose the correct answer from the options given below :

Options :

70819170741. (a) \rightarrow (ii), (b) \rightarrow (iv), (c) \rightarrow (i), (d) \rightarrow (iii)

70819170742. (a) \rightarrow (ii), (b) \rightarrow (i), (c) \rightarrow (iv), (d) \rightarrow (iii)

70819170743. (a) \rightarrow (iii), (b) \rightarrow (i), (c) \rightarrow (iv), (d) \rightarrow (ii)

70819170744. (a) \rightarrow (iii), (b) \rightarrow (iv), (c) \rightarrow (i), (d) \rightarrow (ii)

Question Number : 46 Question Id : 70819121859 Question Type : MCQ Option Shuffling : Yes

Is Question Mandatory : No

Correct Marks : 4 Wrong Marks : 1

ତାଲିକା - I କୁ ତାଲିକା - II ସହିତ ମିଳାଅ ।

ତାଲିକା - I

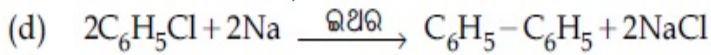
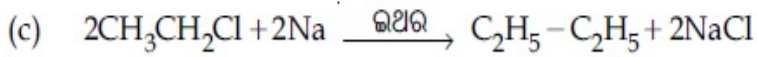
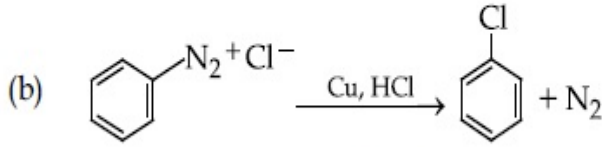
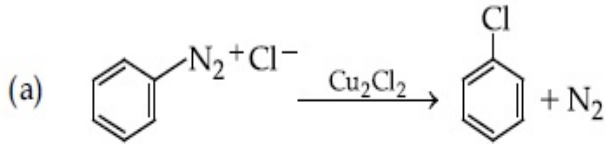

ନିମ୍ନ ବିକଳ୍ପ ମଧ୍ୟରୁ ସଠିକ୍ ଉତ୍ତରଟି ବାଛି :

ତାଲିକା - II

(i) ଉର୍ଦ୍ଧ୍ୱ ପ୍ରତିକ୍ରିୟା

(ii) ସାନ୍ତରଣ ପ୍ରତିକ୍ରିୟା

(iii) ଫିଟିଲ ପ୍ରତିକ୍ରିୟା

(iv) ଗରମମେଲ୍ ପ୍ରତିକ୍ରିୟା

Options :

70819170741. (a) → (ii), (b) → (iv), (c) → (i), (d) → (iii)

70819170742. (a) → (ii), (b) → (i), (c) → (iv), (d) → (iii)

70819170743. (a) → (iii), (b) → (i), (c) → (iv), (d) → (ii)

70819170744. (a) → (iii), (b) → (iv), (c) → (i), (d) → (ii)

Question Number : 47 Question Id : 70819121860 Question Type : MCQ Option Shuffling : Yes

Is Question Mandatory : No

Correct Marks : 4 Wrong Marks : 1

Seliwanoff test and Xanthoproteic test are used for the identification of _____ and _____ respectively.

Options :

70819170745. aldoses, ketoses

70819170746. ketoses, aldoses

70819170747. ketoses, proteins

70819170748. proteins, ketoses

Question Number : 47 Question Id : 70819121860 Question Type : MCQ Option Shuffling : Yes

Is Question Mandatory : No

Correct Marks : 4 Wrong Marks : 1

ସେଲିଓକ୍ସିଡ଼ ପରୀକ୍ଷା ଜାନ୍‌ଥୋପ୍ରୋଟିକ୍ ପରୀକ୍ଷା ଯଥାକ୍ରମେ _____ ଏବଂ _____ କୁ ଚିହ୍ନଟ କରିବା ପାଇଁ ବ୍ୟବହାର ହୁଏ ।

Options :

70819170745. ଆଲଡୋଜ୍‌ସ୍, କିଟୋଜ୍‌ସ୍

70819170746. କିଟୋଜ୍‌ସ୍, ଆଲଡୋଜ୍‌ସ୍

70819170747. କିଟୋଜ୍‌ସ୍, ପ୍ରୋଟିନ୍

70819170748. ପ୍ରୋଟିନ୍, କିଟୋଜ୍‌ସ୍

Question Number : 48 Question Id : 70819121861 Question Type : MCQ Option Shuffling : Yes

Is Question Mandatory : No

Correct Marks : 4 Wrong Marks : 1

Match List-I with List-II.

List-I	List-II
(a) Sucrose	(i) β -D-Galactose and β -D-Glucose
(b) Lactose	(ii) α -D-Glucose and β -D-Fructose
(c) Maltose	(iii) α -D-Glucose and α -D-Glucose

Choose the correct answer from the options given below :

Options :

70819170749. (a) \rightarrow (ii), (b) \rightarrow (i), (c) \rightarrow (iii)

70819170750. (a) → (iii), (b) → (ii), (c) → (i)

70819170751. (a) → (i), (b) → (iii), (c) → (ii)

70819170752. (a) → (iii), (b) → (i), (c) → (ii)

Question Number : 48 Question Id : 70819121861 Question Type : MCQ Option Shuffling : Yes

Is Question Mandatory : No

Correct Marks : 4 Wrong Marks : 1

ତାଲିକା - I କୁ ତାଲିକା - II ସହିତ ମିଳାଅ ।

ତାଲିକା - I

ତାଲିକା - II

(a) ସୁକ୍ରେଜ୍ (i) β -D-ଗାଲକ୍ଟୋଜ୍ ଏବଂ β -D-ଗ୍ଲୁକୋଜ୍

(b) ଲାକ୍ଟୋଜ୍ (ii) α -D-ଗ୍ଲୁକୋଜ୍ ଏବଂ β -D-ଫ୍ରୁକ୍ଟୋଜ୍

(c) ମାଲ୍ଟୋଜ୍ (iii) α -D-ଗ୍ଲୁକୋଜ୍ ଏବଂ α -D-ଗ୍ଲୁକୋଜ୍

ସଠିକ୍ ଉତ୍ତରକୁ ନିମ୍ନ ବିକଳ୍ପ ମଧ୍ୟରୁ ବାଛ ।

Options :

70819170749. (a) → (ii), (b) → (i), (c) → (iii)

70819170750. (a) → (iii), (b) → (ii), (c) → (i)

70819170751. (a) → (i), (b) → (iii), (c) → (ii)

70819170752. (a) → (iii), (b) → (i), (c) → (ii)

Question Number : 49 Question Id : 70819121862 Question Type : MCQ Option Shuffling : Yes

Is Question Mandatory : No

Correct Marks : 4 Wrong Marks : 1

2,4-DNP test can be used to identify :

Options :

70819170753. halogens

70819170754. aldehyde

70819170755. amine

70819170756. ether

Question Number : 49 Question Id : 70819121862 Question Type : MCQ Option Shuffling : Yes

Is Question Mandatory : No

Correct Marks : 4 Wrong Marks : 1

2, 4-DNP ପରୀକ୍ଷାଟି ବ୍ୟବହୃତ ହୁଏ, ଚିହ୍ନଟିକରାକୁ :

Options :

70819170753. ହାଲୋଜେନ୍ସ

70819170754. ଆଲଡିହାଇଡ୍

70819170755. ଆମିନ୍

70819170756. ଇଥର

Question Number : 50 Question Id : 70819121863 Question Type : MCQ Option Shuffling : Yes

Is Question Mandatory : No

Correct Marks : 4 Wrong Marks : 1

A. Phenyl methanamine

B. N,N-Dimethylaniline

C. N-Methyl aniline

D. Benzenamine

Choose the correct order of basic nature of the above amines.

Options :

70819170757. $A > B > C > D$

70819170758. $D > C > B > A$

70819170759. $A > C > B > D$

70819170760. $D > B > C > A$

Question Number : 50 Question Id : 70819121863 Question Type : MCQ Option Shuffling : Yes

Is Question Mandatory : No

Correct Marks : 4 Wrong Marks : 1

(A) ଫିନାୟିଲ୍ ମିଥାନାମାଇନ୍

(B) N,N- ଡାଇମିଥାୟିଲ୍ ଆନିଲିନ୍

(C) N- ମିଥାୟିଲ୍ ଆନିଲିନ୍

(D) ବେଞ୍ଜିନାମାଇନ୍

ଉପରୋକ୍ତ ଆମିନ୍ ଗୁଡ଼ିକର କ୍ଷାରୀୟ ଗୁଣର ସଠିକ୍ କ୍ରମଟି ନିମ୍ନ ବିକଳ୍ପରୁ ବାଛି :

Options :

70819170757. $A > B > C > D$

70819170758. $D > C > B > A$

70819170759. $A > C > B > D$

70819170760. $D > B > C > A$

Chemistry Section B

Section Number :	4
Section type :	Online
Mandatory or Optional :	Mandatory
Number of Questions :	10
Number of Questions to be attempted :	5
Section Marks :	20
Mark As Answered Required? :	Yes
Sub-Section Number :	1
Sub-Section Id :	7081911277
Question Shuffling Allowed :	Yes

Question Number : 51 Question Id : 70819121864 Question Type : SA

Correct Marks : 4 Wrong Marks : 0

The NaNO_3 weighed out to make 50 mL of an aqueous solution containing 70.0 mg Na^+ per mL is _____ g. (Rounded off to the nearest integer)

[Given : Atomic weight in g mol^{-1} - Na : 23 ; N : 14 ; O : 16]

Response Type : Numeric

Evaluation Required For SA : Yes

Show Word Count : Yes

Answers Type : Range

Text Areas : PlainText

Possible Answers :

5 to 5.001

Question Number : 51 Question Id : 70819121864 Question Type : SA

Correct Marks : 4 Wrong Marks : 0

ପ୍ରତି mL ରେ 70.0 mg Na^+ ଆୟନ ଥିବା 50 mL ର ଏକ ଜଳୀୟ ଦ୍ରବଣ ତିଆରି ପାଇଁ _____ ଗ୍ରାମ NaNO_3 ଓଜନ କରାଯାଏ । (ନିକଟତମ ପୂର୍ଣ୍ଣ ସଂଖ୍ୟା)

(ପ୍ରଦତ୍ତ: ପରମାଣବିକ ଗୁରୁତ୍ୱ g mol^{-1} ରେ Na : 23 ; N : 14 ; O : 16)

Response Type : Numeric

Evaluation Required For SA : Yes

Show Word Count : Yes

Answers Type : Range

Text Areas : PlainText

Possible Answers :

5 to 5.001

Question Number : 52 Question Id : 70819121865 Question Type : SA

Correct Marks : 4 Wrong Marks : 0

The number of octahedral voids per lattice site in a lattice is _____. (Rounded off to the nearest integer)

Response Type : Numeric

Evaluation Required For SA : Yes

Show Word Count : Yes

Answers Type : Range

Text Areas : PlainText

Possible Answers :

5 to 5.001

Question Number : 52 Question Id : 70819121865 Question Type : SA

Correct Marks : 4 Wrong Marks : 0

ଏକ ଜାଲକରେ ଥିବା ଅଷ୍ଟପକ୍ଷୀୟ ଶୂନ୍ୟର ସଂଖ୍ୟା ପ୍ରତି ଜାଲକ ସ୍ଥାନ ପାଇଁ ହେଉଛି _____ । (ପୂର୍ଣ୍ଣ ସଂଖ୍ୟାରେ ଉତ୍ତର)

Response Type : Numeric

Evaluation Required For SA : Yes

Show Word Count : Yes

Answers Type : Range

Text Areas : PlainText

Possible Answers :

5 to 5.001

Question Number : 53 Question Id : 70819121866 Question Type : SA

Correct Marks : 4 Wrong Marks : 0

A ball weighing 10 g is moving with a velocity of 90 ms^{-1} . If the uncertainty in its velocity is 5%, then the uncertainty in its position is _____ $\times 10^{-33} \text{ m}$. (Rounded off to the nearest integer)

[Given : $h = 6.63 \times 10^{-34} \text{ Js}$]

Response Type : Numeric

Evaluation Required For SA : Yes

Show Word Count : Yes

Answers Type : Range

Text Areas : PlainText

Possible Answers :

5 to 5.001

Question Number : 53 Question Id : 70819121866 Question Type : SA

Correct Marks : 4 Wrong Marks : 0

10 ଗ୍ରାମ ଓଜନର ଗୋଟିଏ ବଲ୍ 90 ms^{-1} ପରିବେଗରେ ଗତି କରୁଛି । ଏହାର ପରିବେଗର ଅନିଶ୍ଚିତତା ଯଦି 5% ହୁଏ, ତାହେଲେ ଏହାର ସ୍ଥାନର ଅନିଶ୍ଚିତତା ହେଉଛି _____ $\times 10^{-33} \text{ m}$ । (ପୂର୍ଣ୍ଣ ସଂଖ୍ୟାରେ ଉତ୍ତର)

(ପ୍ରଦତ୍ତ: $h = 6.63 \times 10^{-34} \text{ Js}$)

Response Type : Numeric

Evaluation Required For SA : Yes

Show Word Count : Yes

Answers Type : Range

Text Areas : PlainText

Possible Answers :

5 to 5.001

Question Number : 54 Question Id : 70819121867 Question Type : SA

Correct Marks : 4 Wrong Marks : 0

The average S–F bond energy in kJ mol^{-1} of SF_6 is _____. (Rounded off to the nearest integer)

[Given : The values of standard enthalpy of formation of $\text{SF}_6(\text{g})$, $\text{S}(\text{g})$ and $\text{F}(\text{g})$ are - 1100, 275 and 80 kJ mol^{-1} respectively.]

Response Type : Numeric

Evaluation Required For SA : Yes

Show Word Count : Yes

Answers Type : Range

Text Areas : PlainText

Possible Answers :

5 to 5.001

Question Number : 54 **Question Id :** 70819121867 **Question Type :** SA

Correct Marks : 4 **Wrong Marks :** 0

SF_6 ର ହାରାହାରି ବନ୍ଧଶକ୍ତି kJ mol^{-1} ରେ ହେଉଛି _____ । (ନିକଟତମ ପୂର୍ଣ୍ଣସଂଖ୍ୟାରେ ଉତ୍ତର)

ପ୍ରଦତ୍ତ: $\text{SF}_6(\text{g})$, $\text{S}(\text{g})$ ଏବଂ $\text{F}(\text{g})$ ର ଗଠନ ପାଇଁ ଷ୍ଟାଣ୍ଡାର୍ଡ ଏନ୍ଥାଲପି ହେଉଛି ଯଥାକ୍ରମେ - 1100, 275 ଏବଂ 80 kJ mol^{-1} ।

Response Type : Numeric

Evaluation Required For SA : Yes

Show Word Count : Yes

Answers Type : Range

Text Areas : PlainText

Possible Answers :

5 to 5.001

Question Number : 55 **Question Id :** 70819121868 **Question Type :** SA

Correct Marks : 4 **Wrong Marks :** 0

When 12.2 g of benzoic acid is dissolved in 100 g of water, the freezing point of solution was found to be -0.93°C ($K_f(\text{H}_2\text{O}) = 1.86 \text{ K kg mol}^{-1}$). The number (n) of benzoic acid molecules associated (assuming 100% association) is _____.

Response Type : Numeric

Evaluation Required For SA : Yes

Show Word Count : Yes

Answers Type : Range

Text Areas : PlainText

Possible Answers :

5 to 5.001

Question Number : 55 **Question Id :** 70819121868 **Question Type :** SA

Correct Marks : 4 **Wrong Marks :** 0

100 ଗ୍ରାମ୍ ଜଳରେ 12.2 ଗ୍ରାମ୍ ବେଞ୍ଜୋଇକ୍ ଅମ୍ଳ ଦ୍ରବୀଭୂତ କଲେ ଦ୍ରବଣର ହିମାଙ୍କ -0.93°C ଦେଖାଏ ।
($K_f(\text{H}_2\text{O})=1.86 \text{ K kg mol}^{-1}$)
ବେଞ୍ଜୋଇକ୍ ଅମ୍ଳର ଏକତ୍ରିତ ଅଣୁର ସଂଖ୍ୟା (n) ହେଉଛି _____ ।
(ଧରାଯାଉ 100% ଏକତ୍ରିତ ହେଉଛି)_____.

Response Type : Numeric

Evaluation Required For SA : Yes

Show Word Count : Yes

Answers Type : Range

Text Areas : PlainText

Possible Answers :

5 to 5.001

Question Number : 56 **Question Id :** 70819121869 **Question Type :** SA

Correct Marks : 4 **Wrong Marks :** 0

The pH of ammonium phosphate solution, if pK_a of phosphoric acid and pK_b of ammonium hydroxide are 5.23 and 4.75 respectively, is _____.

Response Type : Numeric

Evaluation Required For SA : Yes

Show Word Count : Yes

Answers Type : Range

Text Areas : PlainText

Possible Answers :

5 to 5.001

Question Number : 56 Question Id : 70819121869 Question Type : SA

Correct Marks : 4 Wrong Marks : 0

ଯଦି ଫସଫୋରିକ୍ ଅମ୍ଳର pK_a ଏବଂ ଆମୋନିୟମ୍ ହାଇଡ୍ରୋକ୍ସାଇଡ୍‌ର pK_b ମୂଲ୍ୟ ଯଥାକ୍ରମେ 5.23 ଏବଂ 4.75 ହୁଏ ତା ହେଲେ ଆମୋନିୟମ୍ ଫସଫେଟ୍ ଦ୍ରବଣର pH ହେଉଛି _____ ।

Response Type : Numeric

Evaluation Required For SA : Yes

Show Word Count : Yes

Answers Type : Range

Text Areas : PlainText

Possible Answers :

5 to 5.001

Question Number : 57 Question Id : 70819121870 Question Type : SA

Correct Marks : 4 Wrong Marks : 0

Emf of the following cell at 298 K in V is $x \times 10^{-2}$.

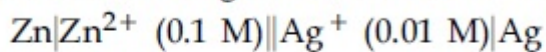

The value of x is _____. (Rounded off to the nearest integer)

[Given : $E_{\text{Zn}^{2+}/\text{Zn}}^{\theta} = -0.76 \text{ V}$; $E_{\text{Ag}^+/\text{Ag}}^{\theta} = +0.80 \text{ V}$; $\frac{2.303RT}{F} = 0.059$]

Response Type : Numeric

Evaluation Required For SA : Yes

Show Word Count : Yes

Answers Type : Range

Text Areas : PlainText

Possible Answers :

5 to 5.001

Question Number : 57 Question Id : 70819121870 Question Type : SA

Correct Marks : 4 Wrong Marks : 0

298 K ରେ ନିମ୍ନଲିଖିତ କୋଷର emf V ରେ ହେଉଛି $x \times 10^{-2}$ ।

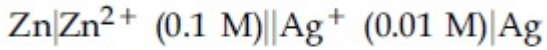

x ର ମୂଲ୍ୟ ହେଉଛି _____ । (ନିକଟତମ ପୂର୍ଣ୍ଣ ସଂଖ୍ୟା)

(ପ୍ରଦତ୍ତ : $E_{\text{Zn}^{2+}/\text{Zn}}^{\theta} = -0.76 \text{ V}$; $E_{\text{Ag}^+/\text{Ag}}^{\theta} = +0.80 \text{ V}$; $\frac{2.303RT}{F} = 0.059$)

Response Type : Numeric

Evaluation Required For SA : Yes

Show Word Count : Yes

Answers Type : Range

Text Areas : PlainText

Possible Answers :

5 to 5.001

Question Number : 58 Question Id : 70819121871 Question Type : SA

Correct Marks : 4 Wrong Marks : 0

If the activation energy of a reaction is 80.9 kJ mol^{-1} , the fraction of molecules at 700 K, having enough energy to react to form products is e^{-x} . The value of x is _____.
(Rounded off to the nearest integer)

[Use $R = 8.31 \text{ J K}^{-1} \text{ mol}^{-1}$]

Response Type : Numeric

Evaluation Required For SA : Yes

Show Word Count : Yes

Answers Type : Range

Text Areas : PlainText

Possible Answers :

5 to 5.001

Question Number : 58 Question Id : 70819121871 Question Type : SA

Correct Marks : 4 Wrong Marks : 0

ଯଦି ଏକ ପ୍ରତିକ୍ରିୟାର ସକ୍ରିୟତା ଶକ୍ତି 80.9 kJ mol^{-1} , 700 K ରେ ଯଥେଷ୍ଟ ଶକ୍ତି ଥାଇ ପ୍ରତିକ୍ରିୟା କରି ଉତ୍ପାଦ ଗଠନ କରୁଥିବା ଅଣୁର ଅଂଶଟି ହେବ e^{-x} ।

x ର ମୂଲ୍ୟ ହେଉଛି _____ ।

(ନିକଟତମ ପୂର୍ଣ୍ଣ ସଂଖ୍ୟା) [ବ୍ୟବହାର କର : $R=8.31 \text{ J K}^{-1} \text{ mol}^{-1}$]

Response Type : Numeric

Evaluation Required For SA : Yes

Show Word Count : Yes

Answers Type : Range

Text Areas : PlainText

Possible Answers :

5 to 5.001

Question Number : 59 **Question Id :** 70819121872 **Question Type :** SA

Correct Marks : 4 **Wrong Marks :** 0

In mildly alkaline medium, thiosulphate ion is oxidized by MnO_4^- to "A". The oxidation state of sulphur in "A" is _____.

Response Type : Numeric

Evaluation Required For SA : Yes

Show Word Count : Yes

Answers Type : Range

Text Areas : PlainText

Possible Answers :

5 to 5.001

Question Number : 59 **Question Id :** 70819121872 **Question Type :** SA

Correct Marks : 4 **Wrong Marks :** 0

ଥାଇୋସଲ୍‌ଫେଟ୍ ଆୟନ୍ ମଧ୍ୟ ଧରଣର ସ୍ଵାରାଜ୍ୟ ମାଧ୍ୟମରେ MnO_4^- ଦ୍ଵାରା ଜାରିତ ହୋଇ "A" ଦିଏ । 'A'ରେ ସଲ୍‌ଫରର ଜାରଣ ଅବସ୍ଥା ହେଉଛି _____ ।

Response Type : Numeric

Evaluation Required For SA : Yes

Show Word Count : Yes

Answers Type : Range

Text Areas : PlainText

Possible Answers :

5 to 5.001

Question Number : 60 **Question Id :** 70819121873 **Question Type :** SA

Correct Marks : 4 **Wrong Marks :** 0

The number of stereoisomers possible for $[\text{Co}(\text{ox})_2(\text{Br})(\text{NH}_3)]^{2-}$ is _____.
[ox = oxalate]

Response Type : Numeric

Evaluation Required For SA : Yes

Show Word Count : Yes

Answers Type : Range

Text Areas : PlainText

Possible Answers :

5 to 5.001

Question Number : 60 **Question Id :** 70819121873 **Question Type :** SA

Correct Marks : 4 **Wrong Marks :** 0

$[\text{Co}(\text{ox})_2(\text{Br})(\text{NH}_3)]^{2-}$ ରେ ଦ୍ୱିମାତ୍ରିକ ସମାବନ୍ଧବର ସମ୍ଭାବିତ ସଂଖ୍ୟା ହେଉଛି _____ ।
[ox = ଅକ୍ସାଲେଟ୍]

Response Type : Numeric

Evaluation Required For SA : Yes

Show Word Count : Yes

Answers Type : Range

Text Areas : PlainText

Possible Answers :

5 to 5.001

Mathematics Section A

Section Id :	708191998
Section Number :	5
Section type :	Online
Mandatory or Optional :	Mandatory
Number of Questions :	20
Number of Questions to be attempted :	20
Section Marks :	80
Mark As Answered Required? :	Yes
Sub-Section Number :	1
Sub-Section Id :	7081911278
Question Shuffling Allowed :	Yes

Question Number : 61 Question Id : 70819121874 Question Type : MCQ Option Shuffling : Yes
Is Question Mandatory : No

Correct Marks : 4 Wrong Marks : 1

If the mirror image of the point $(1, 3, 5)$ with respect to the plane $4x - 5y + 2z = 8$ is (α, β, γ) , then $5(\alpha + \beta + \gamma)$ equals :

Options :

70819170771. 39

70819170772. 41

70819170773. 43

70819170774. 47

Question Number : 61 Question Id : 70819121874 Question Type : MCQ Option Shuffling : Yes

Is Question Mandatory : No

Correct Marks : 4 Wrong Marks : 1

ଯଦି $(1, 3, 5)$ ବିନ୍ଦୁଟିର $4x - 5y + 2z = 8$ ସମତଳ ଭିତ୍ତିକ ପ୍ରତିବିମ୍ବ ବିନ୍ଦୁର ସ୍ଥାନାଙ୍କ (α, β, γ) ଅଟେ, ତେବେ $5(\alpha + \beta + \gamma)$ ସମାନ :

Options :

70819170771. 39

70819170772. 41

70819170773. 43

70819170774. 47

Question Number : 62 Question Id : 70819121875 Question Type : MCQ Option Shuffling : Yes

Is Question Mandatory : No

Correct Marks : 4 Wrong Marks : 1

Let $A = \{1, 2, 3, \dots, 10\}$ and $f: A \rightarrow A$ be defined as

$$f(k) = \begin{cases} k + 1 & \text{if } k \text{ is odd} \\ k & \text{if } k \text{ is even} \end{cases}$$

Then the number of possible functions $g: A \rightarrow A$ such that $g \circ f = f$ is :

Options :

70819170775. $5!$

70819170776. ${}^{10}C_5$

70819170777. 5^5

70819170778. 10^5

Question Number : 62 Question Id : 70819121875 Question Type : MCQ Option Shuffling : Yes

Is Question Mandatory : No

Correct Marks : 4 Wrong Marks : 1

ମନେକର ସେଟ୍ $A = \{1, 2, 3, \dots, 10\}$ ଏବଂ $f: A \rightarrow A$ ଫଳନଟିକୁ

$$f(k) = \begin{cases} k + 1, & \text{ଯଦି } k \text{ ଅଯୁଗ୍ମ ଅଟେ} \\ k, & \text{ଯଦି } k \text{ ଯୁଗ୍ମ ଅଟେ,} \end{cases}$$

ଏହିପରି ପ୍ରକାଶ କରାଯାଏ, ତେବେ g ଫଳନଟିର ସଂଖ୍ୟା, ଯେଉଁଠି $g: A \rightarrow A$ ଓ $gof=f$, ଅଟେ :

Options :

70819170775. $5!$

70819170776. ${}^{10}C_5$

70819170777. 5^5

70819170778. 10^5

Question Number : 63 Question Id : 70819121876 Question Type : MCQ Option Shuffling : Yes

Is Question Mandatory : No

Correct Marks : 4 Wrong Marks : 1

Let A_1 be the area of the region bounded by the curves $y = \sin x$, $y = \cos x$ and y -axis in the first quadrant. Also, let A_2 be the area of the region bounded by the curves $y = \sin x$, $y = \cos x$,

x -axis and $x = \frac{\pi}{2}$ in the first quadrant. Then,

Options :

70819170779. $A_1 : A_2 = 1 : 2$ and $A_1 + A_2 = 1$

70819170780. $A_1 : A_2 = 1 : \sqrt{2}$ and $A_1 + A_2 = 1$

70819170781. $A_1 = A_2$ and $A_1 + A_2 = \sqrt{2}$

70819170782. $2A_1 = A_2$ and $A_1 + A_2 = 1 + \sqrt{2}$

Question Number : 63 Question Id : 70819121876 Question Type : MCQ Option Shuffling : Yes
Is Question Mandatory : No

Correct Marks : 4 Wrong Marks : 1

ମନେକର ପ୍ରଥମପାଦରେ ଅବସ୍ଥିତ ବକ୍ରରେଖା $y = \sin x$, $y = \cos x$ ଓ y - ଅକ୍ଷ ଦ୍ୱାରା ଆବଦ୍ଧ କ୍ଷେତ୍ରର କ୍ଷେତ୍ରଫଳ A_1 ଏବଂ

ବକ୍ରରେଖା $y = \sin x$, $y = \cos x$, x - ଅକ୍ଷ ଓ $x = \frac{\pi}{2}$ ଦ୍ୱାରା ଆବଦ୍ଧ କ୍ଷେତ୍ରର କ୍ଷେତ୍ରଫଳ A_2 । ତେବେ

Options :

70819170779. $A_1 : A_2 = 1 : 2$ ଏବଂ $A_1 + A_2 = 1$

70819170780. $A_1 : A_2 = 1 : \sqrt{2}$ ଏବଂ $A_1 + A_2 = 1$

70819170781. $A_1 = A_2$ ଏବଂ $A_1 + A_2 = \sqrt{2}$

70819170782. $2A_1 = A_2$ ଏବଂ $A_1 + A_2 = 1 + \sqrt{2}$

Question Number : 64 Question Id : 70819121877 Question Type : MCQ Option Shuffling : Yes
Is Question Mandatory : No

Correct Marks : 4 Wrong Marks : 1

If $0 < a, b < 1$, and $\tan^{-1} a + \tan^{-1} b = \frac{\pi}{4}$, then the value of

$$(a + b) - \left(\frac{a^2 + b^2}{2} \right) + \left(\frac{a^3 + b^3}{3} \right) - \left(\frac{a^4 + b^4}{4} \right) + \dots \text{ is:}$$

Options :

70819170783. e

70819170784. $e^2 - 1$

70819170785. $\log_e 2$

70819170786. $\log_e \left(\frac{e}{2} \right)$

Question Number : 64 Question Id : 70819121877 Question Type : MCQ Option Shuffling : Yes

Is Question Mandatory : No

Correct Marks : 4 Wrong Marks : 1

ଯଦି $0 < a, b < 1$, ଏବଂ $\tan^{-1} a + \tan^{-1} b = \frac{\pi}{4}$, ତେବେ

$(a + b) - \left(\frac{a^2 + b^2}{2} \right) + \left(\frac{a^3 + b^3}{3} \right) - \left(\frac{a^4 + b^4}{4} \right) + \dots$ ର ମୂଲ୍ୟ ଅଟେ :

Options :

70819170783. e

70819170784. $e^2 - 1$

70819170785. $\log_e 2$

70819170786. $\log_e \left(\frac{e}{2} \right)$

Question Number : 65 Question Id : 70819121878 Question Type : MCQ Option Shuffling : Yes

Is Question Mandatory : No

Correct Marks : 4 Wrong Marks : 1

Let slope of the tangent line to a curve at any point $P(x, y)$ be given by $\frac{xy^2 + y}{x}$. If the curve

intersects the line $x + 2y = 4$ at $x = -2$, then the value of y , for which the point $(3, y)$ lies on the curve, is :

Options :

70819170787. $-\frac{4}{3}$

70819170788. $-\frac{18}{19}$

70819170789. $\frac{18}{35}$

70819170790. $-\frac{18}{11}$

Question Number : 65 Question Id : 70819121878 Question Type : MCQ Option Shuffling : Yes

Is Question Mandatory : No

Correct Marks : 4 Wrong Marks : 1

ମନେକର ବକ୍ରରେଖାର ଯେକୌଣସି ବିନ୍ଦୁ $P(x, y)$ ଠାରେ ସ୍ପର୍ଶକର ସ୍ଲୋପ୍ $\frac{xy^2 + y}{x}$ । ଯଦି ବକ୍ରରେଖାଟି, $x + 2y = 4$

ସରଳରେଖାକୁ $x = -2$ ଠାରେ ଛେଦ କରେ, ତେବେ ବିନ୍ଦୁ $(3, y)$ ବକ୍ରରେଖା ଉପରେ ଅବସ୍ଥାନ କଲେ y ର ମୂଲ୍ୟ ଅଟେ :

Options :

70819170787. $-\frac{4}{3}$

70819170788. $-\frac{18}{19}$

70819170789. $\frac{18}{35}$

70819170790. $-\frac{18}{11}$

Question Number : 66 Question Id : 70819121879 Question Type : MCQ Option Shuffling : Yes

Is Question Mandatory : No

Correct Marks : 4 Wrong Marks : 1

The sum of the series $\sum_{n=1}^{\infty} \frac{n^2 + 6n + 10}{(2n + 1)!}$ is equal to :

Options :

70819170791. $\frac{41}{8}e + \frac{19}{8}e^{-1} - 10$

70819170792. $\frac{41}{8}e + \frac{19}{8}e^{-1} + 10$

70819170793. $-\frac{41}{8}e + \frac{19}{8}e^{-1} - 10$

70819170794. $\frac{41}{8}e - \frac{19}{8}e^{-1} - 10$

Question Number : 66 Question Id : 70819121879 Question Type : MCQ Option Shuffling : Yes

Is Question Mandatory : No

Correct Marks : 4 Wrong Marks : 1

$\sum_{n=1}^{\infty} \frac{n^2 + 6n + 10}{(2n + 1)!}$ ଶ୍ରେଣୀଟିର ମିଶାଣ ଫଳ ସମାନ :

Options :

70819170791. $\frac{41}{8}e + \frac{19}{8}e^{-1} - 10$

70819170792. $\frac{41}{8}e + \frac{19}{8}e^{-1} + 10$

70819170793. $-\frac{41}{8}e + \frac{19}{8}e^{-1} - 10$

70819170794. $\frac{41}{8}e - \frac{19}{8}e^{-1} - 10$

Question Number : 67 Question Id : 70819121880 Question Type : MCQ Option Shuffling : Yes

Is Question Mandatory : No

Correct Marks : 4 Wrong Marks : 1

Let $f(x) = \int_0^x e^t f(t) dt + e^x$ be a differentiable function for all $x \in \mathbb{R}$. Then $f(x)$ equals :

Options :

70819170795. $2e^{(e^x-1)} - 1$

70819170796. $e^{(e^x-1)}$

70819170797. $e^{e^x} - 1$

70819170798. $2e^{e^x} - 1$

Question Number : 67 Question Id : 70819121880 Question Type : MCQ Option Shuffling : Yes

Is Question Mandatory : No

Correct Marks : 4 Wrong Marks : 1

ମନେକର $f(x) = \int_0^x e^t f(t) dt + e^x$ ଫଳନଟି, x ର ସମସ୍ତ ବାସ୍ତବ ସଂଖ୍ୟା ପୂଲ୍ୟ ପାଇଁ ଅବକଳନୀୟ । ତେବେ $f(x)$ ର

ପୂଲ୍ୟ ସମାପନ :

Options :

70819170795. $2e^{(e^x-1)} - 1$

70819170796. $e^{(e^x-1)}$

70819170797. $e^{e^x} - 1$

70819170798. $2e^{e^x} - 1$

Question Number : 68 Question Id : 70819121881 Question Type : MCQ Option Shuffling : Yes

Is Question Mandatory : No

Correct Marks : 4 Wrong Marks : 1

Let $f(x)$ be a differentiable function at $x = a$ with $f'(a) = 2$ and $f(a) = 4$. Then $\lim_{x \rightarrow a} \frac{xf(a) - af(x)}{x - a}$ equals:

Options :

70819170799. $2a - 4$

70819170800. $4 - 2a$

70819170801. $2a + 4$

70819170802. $a + 4$

Question Number : 68 Question Id : 70819121881 Question Type : MCQ Option Shuffling : Yes

Is Question Mandatory : No

Correct Marks : 4 Wrong Marks : 1

ଯଦି $x = a$ ଠାରେ $f(x)$ ଏକ ଅବକଳନୀୟ ଫଳନ ହେଉଛି ଏବଂ $f'(a) = 2$ ଓ $f(a) = 4$, ତେବେ $\lim_{x \rightarrow a} \frac{xf(a) - af(x)}{x - a}$

ସମାଧାନ :

Options :

70819170799. $2a - 4$

70819170800. $4 - 2a$

70819170801. $2a + 4$

70819170802. $a + 4$

Question Number : 69 Question Id : 70819121882 Question Type : MCQ Option Shuffling : Yes

Is Question Mandatory : No

Correct Marks : 4 Wrong Marks : 1

Let $f(x) = \sin^{-1} x$ and $g(x) = \frac{x^2 - x - 2}{2x^2 - x - 6}$. If $g(2) = \lim_{x \rightarrow 2} g(x)$, then the domain of the function $f \circ g$ is :

Options :

70819170803. $(-\infty, -2] \cup \left[-\frac{3}{2}, \infty\right)$

70819170804. $(-\infty, -2] \cup \left[-\frac{4}{3}, \infty\right)$

70819170805. $(-\infty, -1] \cup [2, \infty)$

70819170806. $(-\infty, -2] \cup [-1, \infty)$

Question Number : 69 Question Id : 70819121882 Question Type : MCQ Option Shuffling : Yes

Is Question Mandatory : No

Correct Marks : 4 Wrong Marks : 1

ମନେକର $f(x) = \sin^{-1} x$ ଏବଂ $g(x) = \frac{x^2 - x - 2}{2x^2 - x - 6}$ । ଯଦି $g(2) = \lim_{x \rightarrow 2} g(x)$, ତେବେ $f \circ g$ ଫଳନଟିର ପରିସର

ଅଟେ :

Options :

70819170803. $(-\infty, -2] \cup \left[-\frac{3}{2}, \infty\right)$

70819170804. $(-\infty, -2] \cup \left[-\frac{4}{3}, \infty\right)$

70819170805. $(-\infty, -1] \cup [2, \infty)$

70819170806. $(-\infty, -2] \cup [-1, \infty)$

Question Number : 70 Question Id : 70819121883 Question Type : MCQ Option Shuffling : Yes

Is Question Mandatory : No

Correct Marks : 4 Wrong Marks : 1

Let A(1, 4) and B(1, -5) be two points. Let P be a point on the circle $(x-1)^2 + (y-1)^2 = 1$ such that $(PA)^2 + (PB)^2$ have maximum value, then the points, P, A and B lie on :

Options :

70819170807. an ellipse

70819170808. a hyperbola

70819170809. a parabola

70819170810. a straight line

Question Number : 70 Question Id : 70819121883 Question Type : MCQ Option Shuffling : Yes

Is Question Mandatory : No

Correct Marks : 4 Wrong Marks : 1

ମନେକର $A(1, 4)$ ଏବଂ $B(1, -5)$ ଦୁଇଗୋଟି ବିନ୍ଦୁ । P , ବୃତ୍ତ $(x-1)^2 + (y-1)^2 = 1$ ଉପରିସ୍ଥ ଏପରି ଏକ ବିନ୍ଦୁ ଯେପରିକି $(PA)^2 + (PB)^2$ ର ମୂଲ୍ୟ ସର୍ବାଧିକ ହେବ, ତେବେ P , A ଓ B ବିନ୍ଦୁଗୁଡ଼ିକ ଅବସ୍ଥାନ କରିବା ପୃଷ୍ଠ :

Options :

70819170807. an ellipse

70819170808. a hyperbola

70819170809. a parabola

70819170810. a straight line

Question Number : 71 Question Id : 70819121884 Question Type : MCQ Option Shuffling : Yes

Is Question Mandatory : No

Correct Marks : 4 Wrong Marks : 1

If vectors $\vec{a}_1 = x\hat{i} - \hat{j} + \hat{k}$ and $\vec{a}_2 = \hat{i} + y\hat{j} + z\hat{k}$ are collinear, then a possible unit vector parallel to the vector $x\hat{i} + y\hat{j} + z\hat{k}$ is :

Options :

70819170811. $\frac{1}{\sqrt{2}} (-\hat{j} + \hat{k})$

70819170812. $\frac{1}{\sqrt{3}} (\hat{i} - \hat{j} + \hat{k})$

70819170813. $\frac{1}{\sqrt{3}} (\hat{i} + \hat{j} - \hat{k})$

70819170814. $\frac{1}{\sqrt{2}} (\hat{i} - \hat{j})$

Question Number : 71 Question Id : 70819121884 Question Type : MCQ Option Shuffling : Yes

Is Question Mandatory : No

Correct Marks : 4 Wrong Marks : 1

ଯଦି ଦିଶାଙ୍କ $\vec{a}_1 = x\hat{i} - \hat{j} + \hat{k}$ ଓ $\vec{a}_2 = \hat{i} + y\hat{j} + z\hat{k}$ ଗୁଡ଼ିକ ଏକ ସରଳରେଖା ଉପରେ ଅବସ୍ଥିତ, ତେବେ

ଦିଶାଙ୍କ $x\hat{i} + y\hat{j} + z\hat{k}$ ସହ ସମାନ୍ତର ଗୋଟିଏ ସମ୍ଭବ ଏକକ ଦିଶାଙ୍କ ଅଟେ :

Options :

70819170811. $\frac{1}{\sqrt{2}} (-\hat{j} + \hat{k})$

70819170812. $\frac{1}{\sqrt{3}} (\hat{i} - \hat{j} + \hat{k})$

70819170813. $\frac{1}{\sqrt{3}} (\hat{i} + \hat{j} - \hat{k})$

70819170814. $\frac{1}{\sqrt{2}} (\hat{i} - \hat{j})$

Question Number : 72 Question Id : 70819121885 Question Type : MCQ Option Shuffling : Yes

Is Question Mandatory : No

Correct Marks : 4 Wrong Marks : 1

Let $F_1(A, B, C) = (A \wedge \sim B) \vee [\sim C \wedge (A \vee B)] \vee \sim A$ and $F_2(A, B) = (A \vee B) \vee (B \rightarrow \sim A)$ be two logical expressions. Then :

Options :

70819170815. F_1 and F_2 both are tautologies

70819170816. F_1 is a tautology but F_2 is not a tautology

70819170817. F_1 is not a tautology but F_2 is a tautology

70819170818. Both F_1 and F_2 are not tautologies

**Question Number : 72 Question Id : 70819121885 Question Type : MCQ Option Shuffling : Yes
Is Question Mandatory : No**

Correct Marks : 4 Wrong Marks : 1

ମନେକର $F_1(A, B, C) = (A \wedge \sim B) \vee [\sim C \wedge (A \vee B)] \vee \sim A$ ଏବଂ $F_2(A, B) = (A \vee B) \vee (B \rightarrow \sim A)$ ଦୁଇଟି
ତର୍କସୂତ୍ର ଉକ୍ତି ହୁଅନ୍ତି, ତେବେ :

Options :

70819170815. F_1 ଓ F_2 ଉଭୟ ପୂନରୂପିତ (ଟାଟୋଲୋଜି)

70819170816. F_1 ଏକ ପୂନରୂପିତ କିନ୍ତୁ F_2 ପୂନରୂପିତ ନୁହେଁ

70819170817. F_1 ଏକ ପୂନରୂପିତ ନୁହେଁ କିନ୍ତୁ F_2 ଏକ ପୂନରୂପିତ

70819170818. ଉଭୟ F_1 ଏବଂ F_2 ପୂନରୂପିତ ନୁହଁନ୍ତି

**Question Number : 73 Question Id : 70819121886 Question Type : MCQ Option Shuffling : Yes
Is Question Mandatory : No**

Correct Marks : 4 Wrong Marks : 1

A seven digit number is formed using digits 3, 3, 4, 4, 4, 5, 5. The probability, that number
so formed is divisible by 2, is :

Options :

70819170819. $\frac{3}{7}$

70819170820. $\frac{6}{7}$

70819170821. $\frac{1}{7}$

70819170822. $\frac{4}{7}$

Question Number : 73 Question Id : 70819121886 Question Type : MCQ Option Shuffling : Yes

Is Question Mandatory : No

Correct Marks : 4 Wrong Marks : 1

3, 3, 4, 4, 4, 5, 5 ଅଙ୍କ ଗୁଡ଼ିକୁ ବ୍ୟବହାର କରି ଏକ ସାତ ଅଙ୍କ ବିଶିଷ୍ଟ ସଂଖ୍ୟା ଗଠନ କରାଗଲା । ଏହି ଗଠିତ ସଂଖ୍ୟାଟି 2 ଦ୍ୱାରା ବିଭାଜ୍ୟ ହେବାର ସମ୍ଭାବ୍ୟତା ଅଟେ :

Options :

70819170819. $\frac{3}{7}$

70819170820. $\frac{6}{7}$

70819170821. $\frac{1}{7}$

70819170822. $\frac{4}{7}$

Question Number : 74 Question Id : 70819121887 Question Type : MCQ Option Shuffling : Yes

Is Question Mandatory : No

Correct Marks : 4 Wrong Marks : 1

Consider the following system of equations :

$$x + 2y - 3z = a$$

$$2x + 6y - 11z = b$$

$$x - 2y + 7z = c,$$

where a, b and c are real constants. Then the system of equations :

Options :

70819170823. has a unique solution for all a, b and c

70819170824. has a unique solution when $5a = 2b + c$

70819170825. has infinite number of solutions when $5a = 2b + c$

70819170826. has no solution for all a, b and c

Question Number : 74 Question Id : 70819121887 Question Type : MCQ Option Shuffling : Yes

Is Question Mandatory : No

Correct Marks : 4 Wrong Marks : 1

ନିମ୍ନ ଏକସ୍ଥାପିତ ସମୀକରଣ ସମୂହ :

$$x + 2y - 3z = a$$

$$2x + 6y - 11z = b$$

$$x - 2y + 7z = c,$$

କୁ ବିଚାର କରାଯାଇ ଯେଉଁଠି a, b ଓ c ମାନେ ବାସ୍ତବ ସ୍ଥିରାଙ୍କ । ଏହି ସମୀକରଣ ସମୂହର

Options :

70819170823. କେବଳ ମାତ୍ର ଗୋଟିଏ ସମାଧାନ ଅଛି, ସମସ୍ତ a, b ଓ c ପାଇଁ

70819170824. କେବଳ ଗୋଟିଏ ମାତ୍ର ସମାଧାନ ଅଛି ଯେତେବେଳେ $5a = 2b + c$

70819170825. ଅସୀମ ସଂଖ୍ୟକ ସମାଧାନ ଅଛି ଯେତେବେଳେ $5a = 2b + c$

70819170826. କୌଣସି ସମାଧାନ ନାହିଁ, ସମସ୍ତ a, b ଓ c ପାଇଁ

Question Number : 75 Question Id : 70819121888 Question Type : MCQ Option Shuffling : Yes

Is Question Mandatory : No

Correct Marks : 4 Wrong Marks : 1

The triangle of maximum area that can be inscribed in a given circle of radius 'r' is :

Options :

70819170827. An isosceles triangle with base equal to $2r$.

70819170828. A right angle triangle having two of its sides of length $2r$ and r .

70819170829. An equilateral triangle of height $\frac{2r}{3}$.

70819170830. An equilateral triangle having each of its side of length $\sqrt{3} r$.

Question Number : 75 Question Id : 70819121888 Question Type : MCQ Option Shuffling : Yes

Is Question Mandatory : No

Correct Marks : 4 Wrong Marks : 1

'r' ବ୍ୟାସାର୍ଦ୍ଧ ବିଶିଷ୍ଟ ଏକ ଦତ୍ତ ବୃତ୍ତରେ ସର୍ବାଧିକ କ୍ଷେତ୍ରଫଳ ଥିବା ଏକ ତ୍ରିଭୁଜ ଅଙ୍କନ କରାଯାଇପାରିବ ଯଦି ତ୍ରିଭୁଜଟି ଅଟେ :

Options :

70819170827. ଏକ ସମଦ୍ୱିବାହୁ ତ୍ରିଭୁଜ ଯାହାର ଭୂମି $2r$.

70819170828. ଏକ ସମକୋଣୀ ତ୍ରିଭୁଜ ଯାହାର ଦୁଇଟି ବାହୁର ଲମ୍ବ $2r$ ଓ r .

70819170829. ଏକ ସମବାହୁ ତ୍ରିଭୁଜ ଯାହାର ଉଚ୍ଚତା $\frac{2r}{3}$.

70819170830. ଏକ ସମବାହୁ ତ୍ରିଭୁଜ ଯାହାର ପ୍ରତ୍ୟେକ ବାହୁର ଦୈର୍ଘ୍ୟ $\sqrt{3} r$.

Question Number : 76 Question Id : 70819121889 Question Type : MCQ Option Shuffling : Yes

Is Question Mandatory : No

Correct Marks : 4 Wrong Marks : 1

Let L be a line obtained from the intersection of two planes $x + 2y + z = 6$ and $y + 2z = 4$. If point $P(\alpha, \beta, \gamma)$ is the foot of perpendicular from $(3, 2, 1)$ on L, then the value of $21(\alpha + \beta + \gamma)$ equals :

Options :

70819170831. 68

70819170832. 102

70819170833. 136

70819170834. 142

Question Number : 76 Question Id : 70819121889 Question Type : MCQ Option Shuffling : Yes

Is Question Mandatory : No

Correct Marks : 4 Wrong Marks : 1

ମନେକର ଦୁଇଟି ସମତଳ $x + 2y + z = 6$ ଓ $y + 2z = 4$ ର ଛେଦରୁ L ରେଖାଟି ମିଳିଛି । ଯଦି ବିନ୍ଦୁ $P(\alpha, \beta, \gamma)$ ଟି $(3, 2, 1)$ ବିନ୍ଦୁରୁ L ଉପରେ ଅଙ୍କିତ ଲମ୍ବର ପାଦବିନ୍ଦୁ ହୁଏ, ତେବେ $21(\alpha + \beta + \gamma)$ ର ମୂଲ୍ୟ ସମାନ :

Options :

70819170831. 68

70819170832. 102

70819170833. 136

70819170834. 142

Question Number : 77 Question Id : 70819121890 Question Type : MCQ Option Shuffling : Yes

Is Question Mandatory : No

Correct Marks : 4 Wrong Marks : 1

Let $f: \mathbb{R} \rightarrow \mathbb{R}$ be defined as

$$f(x) = \begin{cases} 2 \sin\left(-\frac{\pi x}{2}\right), & \text{if } x < -1 \\ |ax^2 + x + b|, & \text{if } -1 \leq x \leq 1 \\ \sin(\pi x), & \text{if } x > 1 \end{cases}$$

If $f(x)$ is continuous on \mathbb{R} , then $a + b$ equals :

Options :

70819170835. -3

70819170836. -1

70819170837. 1

70819170838. 3

Question Number : 77 Question Id : 70819121890 Question Type : MCQ Option Shuffling : Yes

Is Question Mandatory : No

Correct Marks : 4 Wrong Marks : 1

ମନେକର $f: \mathbb{R} \rightarrow \mathbb{R}$ ଫଳନଟିକୁ $f(x) = \begin{cases} 2 \sin\left(-\frac{\pi x}{2}\right), & \text{ଯଦି } x < -1 \\ |ax^2 + x + b|, & \text{ଯଦି } -1 \leq x \leq 1 \\ \sin(\pi x), & \text{ଯଦି } x > 1 \end{cases}$ ଏହିପରି ପ୍ରକାଶ କରାଯାଇ ଅଛି ।

ଯଦି $f(x)$ ଫଳନଟି, \mathbb{R} ବାସ୍ତବ ସଂଖ୍ୟା ସେଟ୍ ଉପରେ ନିରବଚ୍ଛିନ୍ନ ଅଟେ ତେବେ $a + b$ ସମାନ :

Options :

70819170835. -3

70819170836. -1

70819170837. 1

70819170838. 3

Question Number : 78 Question Id : 70819121891 Question Type : MCQ Option Shuffling : Yes

Is Question Mandatory : No

Correct Marks : 4 Wrong Marks : 1

If the locus of the mid-point of the line segment from the point (3, 2) to a point on the circle, $x^2 + y^2 = 1$ is a circle of radius r , then r is equal to :

Options :

70819170839. $\frac{1}{4}$

70819170840. $\frac{1}{3}$

70819170841. $\frac{1}{2}$

70819170842. 1

Question Number : 78 Question Id : 70819121891 Question Type : MCQ Option Shuffling : Yes

Is Question Mandatory : No

Correct Marks : 4 Wrong Marks : 1

ଯଦି ବିନ୍ଦୁ (3, 2) ଠାରୁ, $x^2 + y^2 = 1$ ବୃତ୍ତ ଉପରିସ୍ଥ ଏକ ବିନ୍ଦୁ ପ୍ରତି ଅଙ୍କିତ ରେଖାଖଣ୍ଡର ମଧ୍ୟବିନ୍ଦୁମାନଙ୍କର ସଂଚାର ପଥ (ଲୋକସ) r ବ୍ୟାସାର୍ଦ୍ଧ ବିଶିଷ୍ଟ ଏକ ବୃତ୍ତ ହୁଏ, ତେବେ r ସମାନ :

Options :

70819170839. $\frac{1}{4}$

70819170840. $\frac{1}{3}$

70819170841. $\frac{1}{2}$

70819170842. 1

Question Number : 79 Question Id : 70819121892 Question Type : MCQ Option Shuffling : Yes

Is Question Mandatory : No

Correct Marks : 4 Wrong Marks : 1

A natural number has prime factorization given by $n=2^x3^y5^z$, where y and z are such that $y+z=5$ and $y^{-1} + z^{-1} = \frac{5}{6}$, $y > z$. Then the number of odd divisors of n , including 1, is :

Options :

70819170843. 6

70819170844. 11

70819170845. 12

70819170846. $6x$

Question Number : 79 Question Id : 70819121892 Question Type : MCQ Option Shuffling : Yes

Is Question Mandatory : No

Correct Marks : 4 Wrong Marks : 1

ଗୋଟିଏ ଗଣନ ସଂଖ୍ୟାର ମୌଳିକ ବିଭାଜନକୁ $n=2^x3^y5^z$, ଏହିପରି ଲେଖାଯାଇଛି, ଯେଉଁଠି y ଓ z ଏପରି ଯେ $y+z=5$ ଓ $y^{-1} + z^{-1} = \frac{5}{6}$ ($y > z$) । ତେବେ n ର (1 ସହ) ଅଯୁଗ୍ମ ଭାଜକ ସଂଖ୍ୟା ଅଟେ :

Options :

70819170843. 6

70819170844. 11

70819170845. 12

70819170846. $6x$

**Question Number : 80 Question Id : 70819121893 Question Type : MCQ Option Shuffling : Yes
Is Question Mandatory : No**

Correct Marks : 4 Wrong Marks : 1

For $x > 0$, if $f(x) = \int_1^x \frac{\log_e t}{(1+t)} dt$, then $f(e) + f\left(\frac{1}{e}\right)$ is equal to :

Options :

70819170847. 0

70819170848. 1

70819170849. $\frac{1}{2}$

70819170850. -1

**Question Number : 80 Question Id : 70819121893 Question Type : MCQ Option Shuffling : Yes
Is Question Mandatory : No**

Correct Marks : 4 Wrong Marks : 1

$x > 0$ ପାଇଁ, ଯଦି $f(x) = \int_1^x \frac{\log_e t}{(1+t)} dt$, ତେବେ $f(e) + f\left(\frac{1}{e}\right)$ ସମାନ :

Options :

70819170847. 0

70819170848. 1

70819170849. $\frac{1}{2}$

70819170850. -1

Mathematics Section B

Section Id :	708191999
Section Number :	6
Section type :	Online
Mandatory or Optional :	Mandatory
Number of Questions :	10
Number of Questions to be attempted :	5
Section Marks :	20
Mark As Answered Required? :	Yes
Sub-Section Number :	1
Sub-Section Id :	7081911279
Question Shuffling Allowed :	Yes

Question Number : 81 Question Id : 70819121894 Question Type : SA

Correct Marks : 4 Wrong Marks : 0

If $I_{m,n} = \int_0^1 x^{m-1}(1-x)^{n-1} dx$, for $m, n \geq 1$, and $\int_0^1 \frac{x^{m-1} + x^{n-1}}{(1+x)^{m+n}} dx = \alpha I_{m,n}$, $\alpha \in \mathbb{R}$, then α equals _____.

Response Type : Numeric

Evaluation Required For SA : Yes

Show Word Count : Yes

Answers Type : Range

Text Areas : PlainText

Possible Answers :

5 to 5.001

Question Number : 81 **Question Id :** 70819121894 **Question Type :** SA

Correct Marks : 4 **Wrong Marks :** 0

$$\int_0^1 x^{m-1}(1-x)^{n-1} dx, (m, n \geq 1) \propto \int_0^1 \frac{x^{m-1} + x^{n-1}}{(1+x)^{m+n}} dx, (\alpha \in \mathbb{R}),$$

α ସମୀକ୍ଷା _____ ।

Response Type : Numeric

Evaluation Required For SA : Yes

Show Word Count : Yes

Answers Type : Range

Text Areas : PlainText

Possible Answers :

5 to 5.001

Question Number : 82 **Question Id :** 70819121895 **Question Type :** SA

Correct Marks : 4 **Wrong Marks :** 0

Let z be those complex numbers which satisfy

$$|z+5| \leq 4 \text{ and } z(1+i) + \bar{z}(1-i) \geq -10, i = \sqrt{-1}.$$

If the maximum value of $|z+1|^2$ is $\alpha + \beta\sqrt{2}$, then the value of $(\alpha + \beta)$ is _____.

Response Type : Numeric

Evaluation Required For SA : Yes

Show Word Count : Yes

Answers Type : Range

Text Areas : PlainText

Possible Answers :

5 to 5.001

Question Number : 82 Question Id : 70819121895 Question Type : SA

Correct Marks : 4 Wrong Marks : 0

ମନେକର z , ଏପରି କିଛି କମ୍ପ୍ଲେକ୍ସ ସଂଖ୍ୟା ଯାହା $|z+5| \leq 4$ ଓ $z(1+i) + \bar{z}(1-i) \geq -10, i = \sqrt{-1}$. ସର୍ତ୍ତକୁ ମାନୁଅଛି । ଯଦି $|z+1|^2$ ର ସର୍ବାଧିକ ମୂଲ୍ୟ $\alpha + \beta\sqrt{2}$ ହୁଏ, ତେବେ $(\alpha + \beta)$ ର ମୂଲ୍ୟ ଅଟେ _____ ।

Response Type : Numeric

Evaluation Required For SA : Yes

Show Word Count : Yes

Answers Type : Range

Text Areas : PlainText

Possible Answers :

5 to 5.001

Question Number : 83 Question Id : 70819121896 Question Type : SA

Correct Marks : 4 Wrong Marks : 0

Let the normals at all the points on a given curve pass through a fixed point (a, b) . If the curve passes through $(3, -3)$ and $(4, -2\sqrt{2})$, and given that $a - 2\sqrt{2}b = 3$, then $(a^2 + b^2 + ab)$ is equal to _____.

Response Type : Numeric

Evaluation Required For SA : Yes

Show Word Count : Yes

Answers Type : Range

Text Areas : PlainText

Possible Answers :

5 to 5.001

Question Number : 83 Question Id : 70819121896 Question Type : SA

Correct Marks : 4 Wrong Marks : 0

ମନେକର ଦତ୍ତ ଥିବା ଏକ ବକ୍ରରେଖାର ସମସ୍ତ ବିନ୍ଦୁରେ ଅଙ୍କାଯାଇଥିବା ଲମ୍ବ ରେଖା ଗୁଡ଼ିକ ବିନ୍ଦୁ (a, b) ମଧ୍ୟଦେଇ ଗତିକରେ । ଯଦି ବକ୍ରରେଖାଟି $(3, -3)$ ବିନ୍ଦୁ ଓ $(4, -2\sqrt{2})$ ବିନ୍ଦୁ ମଧ୍ୟଦେଇ ଗତି କରେ ଓ ଦିଆଯାଇଅଛି କି $a - 2\sqrt{2}b = 3$, ତେବେ $(a^2 + b^2 + ab)$ ସମାନ ଅଟେ _____।

Response Type : Numeric

Evaluation Required For SA : Yes

Show Word Count : Yes

Answers Type : Range

Text Areas : PlainText

Possible Answers :

5 to 5.001

Question Number : 84 Question Id : 70819121897 Question Type : SA

Correct Marks : 4 Wrong Marks : 0

Let a be an integer such that all the real roots of the polynomial $2x^5 + 5x^4 + 10x^3 + 10x^2 + 10x + 10$ lie in the interval $(a, a + 1)$. Then, $|a|$ is equal to _____.

Response Type : Numeric

Evaluation Required For SA : Yes

Show Word Count : Yes

Answers Type : Range

Text Areas : PlainText

Possible Answers :

5 to 5.001

Question Number : 84 Question Id : 70819121897 Question Type : SA

Correct Marks : 4 Wrong Marks : 0

ମନେକର a ଏକ ପୂର୍ଣ୍ଣସଂଖ୍ୟା ଯେପରିକି $2x^5 + 5x^4 + 10x^3 + 10x^2 + 10x + 10$ ପଲିନୋମିଆଲ୍ (ବହୁରାଶୀୟ) ର ସମସ୍ତ ବାସ୍ତବ ବୀଜ (ମୂଳ) ଗୁଡ଼ିକ $(a, a + 1)$ ଅନ୍ତରାଳରେ ଅବସ୍ଥିତ ହୁଅନ୍ତି । ତେବେ $|a|$ ସମାନ ଅଟେ _____।

Response Type : Numeric

Evaluation Required For SA : Yes

Show Word Count : Yes

Answers Type : Range

Text Areas : PlainText

Possible Answers :

5 to 5.001

Question Number : 85 **Question Id :** 70819121898 **Question Type :** SA

Correct Marks : 4 **Wrong Marks :** 0

Let X_1, X_2, \dots, X_{18} be eighteen observations such that $\sum_{i=1}^{18} (X_i - \alpha) = 36$ and $\sum_{i=1}^{18} (X_i - \beta)^2 = 90$,

where α and β are distinct real numbers. If the standard deviation of these observations is 1, then the value of $|\alpha - \beta|$ is _____.

Response Type : Numeric

Evaluation Required For SA : Yes

Show Word Count : Yes

Answers Type : Range

Text Areas : PlainText

Possible Answers :

5 to 5.001

Question Number : 85 **Question Id :** 70819121898 **Question Type :** SA

Correct Marks : 4 **Wrong Marks :** 0

ଧରାଯାଉ X_1, X_2, \dots, X_{18} 18 ଗୋଟି ପର୍ଯ୍ୟବେକ୍ଷଣ, ଯେପରିକି $\sum_{i=1}^{18} (X_i - \alpha) = 36$ ଓ $\sum_{i=1}^{18} (X_i - \beta)^2 = 90$,

α ଓ β ଦୁଇଟି ପୃଥକ୍ ବାସ୍ତବ ସଂଖ୍ୟା । ଯଦି ଏହି ପର୍ଯ୍ୟବେକ୍ଷଣ ଗୁଡ଼ିକର ମାନକ ବିଚ୍ୟୁତି (S.D) 1 ହୁଏ, ତେବେ $|\alpha - \beta|$ ର ମୂଲ୍ୟ ସମାନ _____ ।

Response Type : Numeric

Evaluation Required For SA : Yes

Show Word Count : Yes

Answers Type : Range

Text Areas : PlainText

Possible Answers :

5 to 5.001

Question Number : 86 Question Id : 70819121899 Question Type : SA

Correct Marks : 4 Wrong Marks : 0

If the matrix $A = \begin{bmatrix} 1 & 0 & 0 \\ 0 & 2 & 0 \\ 3 & 0 & -1 \end{bmatrix}$ satisfies the equation $A^{20} + \alpha A^{19} + \beta A = \begin{bmatrix} 1 & 0 & 0 \\ 0 & 4 & 0 \\ 0 & 0 & 1 \end{bmatrix}$ for some

real numbers α and β , then $\beta - \alpha$ is equal to _____.

Response Type : Numeric

Evaluation Required For SA : Yes

Show Word Count : Yes

Answers Type : Range

Text Areas : PlainText

Possible Answers :

5 to 5.001

Question Number : 86 Question Id : 70819121899 Question Type : SA

Correct Marks : 4 Wrong Marks : 0

ଯଦି ମାଟ୍ରିକ୍ସ $A = \begin{bmatrix} 1 & 0 & 0 \\ 0 & 2 & 0 \\ 3 & 0 & -1 \end{bmatrix}$, α ଓ β ର କୌଣସି ବାସ୍ତବ ମୂଲ୍ୟ ପାଇଁ ସମୀକରଣ

$A^{20} + \alpha A^{19} + \beta A = \begin{bmatrix} 1 & 0 & 0 \\ 0 & 4 & 0 \\ 0 & 0 & 1 \end{bmatrix}$ ଠିକ୍ ସିଦ୍ଧି କରେ, ତେବେ $\beta - \alpha$ ସମାନ :

Response Type : Numeric

Evaluation Required For SA : Yes

Show Word Count : Yes

Answers Type : Range

Text Areas : PlainText

Possible Answers :

5 to 5.001

Question Number : 87 Question Id : 70819121900 Question Type : SA

Correct Marks : 4 Wrong Marks : 0

Let α and β be two real numbers such that $\alpha + \beta = 1$ and $\alpha\beta = -1$. Let $p_n = (\alpha)^n + (\beta)^n$, $p_{n-1} = 11$ and $p_{n+1} = 29$ for some integer $n \geq 1$. Then, the value of p_n^2 is _____.

Response Type : Numeric

Evaluation Required For SA : Yes

Show Word Count : Yes

Answers Type : Range

Text Areas : PlainText

Possible Answers :

5 to 5.001

Question Number : 87 Question Id : 70819121900 Question Type : SA

Correct Marks : 4 Wrong Marks : 0

ମନେକର α ଓ β ଦୁଇଟି ବାସ୍ତବ ସଂଖ୍ୟା ଯେପରିକି $\alpha + \beta = 1$ ଓ $\alpha\beta = -1$ । ଯଦି କୌଣସି ଏକ ପୂର୍ଣ୍ଣ ସଂଖ୍ୟା $n \geq 1$ ପାଇଁ $p_n = (\alpha)^n + (\beta)^n$, $p_{n-1} = 11$ ଏବଂ $p_{n+1} = 29$, ତେବେ p_n^2 ର ମୂଲ୍ୟ ଅଟେ _____ ।

Response Type : Numeric

Evaluation Required For SA : Yes

Show Word Count : Yes

Answers Type : Range

Text Areas : PlainText

Possible Answers :

5 to 5.001

Question Number : 88 Question Id : 70819121901 Question Type : SA

Correct Marks : 4 Wrong Marks : 0

The total number of 4-digit numbers whose greatest common divisor with 18 is 3, is _____.

Response Type : Numeric

Evaluation Required For SA : Yes

Show Word Count : Yes

Answers Type : Range

Text Areas : PlainText

Possible Answers :

5 to 5.001

Question Number : 88 Question Id : 70819121901 Question Type : SA

Correct Marks : 4 Wrong Marks : 0

ଚାରିଅଙ୍କ ବିଶିଷ୍ଟ ସଂଖ୍ୟା ମାନଙ୍କର ମୋଟ ସଂଖ୍ୟା, ଯାହାର 18 ସହ ଗ.ସା.ଗୁ (ଗରିଷ୍ଠ ସାଧାରଣ ଭାଜକ) 3 ଅଟେ, ସେମାନଙ୍କର ସଂଖ୍ୟା ଅଟେ _____।

Response Type : Numeric

Evaluation Required For SA : Yes

Show Word Count : Yes

Answers Type : Range

Text Areas : PlainText

Possible Answers :

5 to 5.001

Question Number : 89 Question Id : 70819121902 Question Type : SA

Correct Marks : 4 Wrong Marks : 0

If the arithmetic mean and geometric mean of the p^{th} and q^{th} terms of the sequence $-16, 8, -4, 2, \dots$ satisfy the equation $4x^2 - 9x + 5 = 0$, then $p + q$ is equal to _____.

Response Type : Numeric

Evaluation Required For SA : Yes

Show Word Count : Yes

Answers Type : Range

Text Areas : PlainText

Possible Answers :

5 to 5.001

Question Number : 89 Question Id : 70819121902 Question Type : SA

Correct Marks : 4 Wrong Marks : 0

ଯଦି $-16, 8, -4, 2, \dots$ ଶ୍ରେଣୀର p ଡ଼ମ ଓ q ଡ଼ମ ପଦର ସମାନ୍ତର ମାଧ୍ୟମାନ ଓ ଗୁଣୋତ୍ତର ମାଧ୍ୟମାନ, ସମୀକରଣ $4x^2 - 9x + 5 = 0$ କୁ ସିଦ୍ଧି କରେ, ତେବେ $p+q$ ସମାନ _____।

Response Type : Numeric

Evaluation Required For SA : Yes

Show Word Count : Yes

Answers Type : Range

Text Areas : PlainText

Possible Answers :

5 to 5.001

Question Number : 90 Question Id : 70819121903 Question Type : SA

Correct Marks : 4 Wrong Marks : 0

Let L be a common tangent line to the curves $4x^2 + 9y^2 = 36$ and $(2x)^2 + (2y)^2 = 31$. Then the square of the slope of the line L is _____.

Response Type : Numeric

Evaluation Required For SA : Yes

Show Word Count : Yes

Answers Type : Range

Text Areas : PlainText

Possible Answers :

5 to 5.001

Question Number : 90 Question Id : 70819121903 Question Type : SA

Correct Marks : 4 Wrong Marks : 0

ମନେକର ଦୁଇଟି ବକ୍ରପୃଷ୍ଠ $4x^2 + 9y^2 = 36$ ଓ $(2x)^2 + (2y)^2 = 31$ ପ୍ରତି, L ଏକ ସାଧାରଣ ସ୍ପର୍ଶକ, ତେବେ ରେଖା L ର ସ୍ଲୋପ୍ ବର୍ଗ ଅଟେ _____।

Response Type : Numeric

Evaluation Required For SA : Yes

Show Word Count : Yes

Answers Type : Range

Text Areas : PlainText

Possible Answers :

5 to 5.001