

National Testing Agency

Question Paper Name :	B TECH EA 16th March 2021 Shift 1
Subject Name :	B TECH EA
Creation Date :	2021-03-16 14:04:32
Duration :	180
Number of Questions :	90
Total Marks :	300
Display Marks:	Yes

B TECH EA

Group Number :	1
Group Id :	8643511
Group Maximum Duration :	0
Group Minimum Duration :	180
Show Attended Group? :	No
Edit Attended Group? :	No
Break time :	0
Group Marks :	300
Is this Group for Examiner? :	No

Physics Section A

Section Id :	8643511
Section Number :	1
Section type :	Online
Mandatory or Optional :	Mandatory
Number of Questions :	20
Number of Questions to be attempted :	20
Section Marks :	80
Mark As Answered Required? :	Yes
Sub-Section Number :	1
Sub-Section Id :	8643511
Question Shuffling Allowed :	Yes

Question Number : 1 Question Id : 8643511 Question Type : MCQ Option Shuffling : Yes Is Question Mandatory : No

Correct Marks : 4 Wrong Marks : 1

For an electromagnetic wave travelling in free space, the relation between average energy densities due to electric (U_e) and magnetic (U_m) fields is :

Options :

8643511. $U_e = U_m$

8643512. $U_e \neq U_m$

8643513. $U_e > U_m$

8643514. $U_e < U_m$

Question Number : 1 Question Id : 8643511 Question Type : MCQ Option Shuffling : Yes Is Question Mandatory : No

Correct Marks : 4 Wrong Marks : 1

শূন্যস্থানত গতি কৰি থকা এটা বিদ্যুৎ চুম্বকীয় তৰংগৰ বাবে, বৈদ্যুতিক (U_e) আৰু চৌম্বিক (U_m) ক্ষেত্ৰৰ বাবে গড় শক্তি ঘনত্বৰ মাজৰ সম্পৰ্ক হয় :

Options :

8643511. $U_e = U_m$

8643512. $U_e \neq U_m$

8643513. $U_e > U_m$

8643514. $U_e < U_m$

Question Number : 2 Question Id : 8643512 Question Type : MCQ Option Shuffling : Yes Is Question Mandatory : No

Correct Marks : 4 Wrong Marks : 1

The volume V of an enclosure contains a mixture of three gases, 16 g of oxygen, 28 g of nitrogen and 44 g of carbon dioxide at absolute temperature T . Consider R as universal gas constant. The pressure of the mixture of gases is :

Options :

8643515. $\frac{5}{2} \frac{RT}{V}$

8643516. $\frac{3RT}{V}$

8643517. $\frac{4RT}{V}$

8643518. $\frac{88RT}{V}$

Question Number : 2 Question Id : 8643512 Question Type : MCQ Option Shuffling : Yes Is Question Mandatory : No

Correct Marks : 4 Wrong Marks : 1

পৰম উষ্ণতা T ত 16 g অক্সিজেন, 28 g নাইট্ৰ'জেন আৰু 44 g কাৰ্বন-ডাই-অক্সাইড, এই তিনিটা গেছৰ মিশ্ৰণ এটা V আয়তনৰ বন্ধ পাত্ৰত আছে। R ক সার্বজনীন গেছ ধ্ৰুৱক ধৰি লোৱা। গেছ মিশ্ৰণটোৰ চাপ হয় :

Options :

8643515. $\frac{5}{2} \frac{RT}{V}$

8643516. $\frac{3RT}{V}$

8643517. $\frac{4RT}{V}$

8643518. $\frac{88RT}{V}$

Question Number : 3 Question Id : 8643513 Question Type : MCQ Option Shuffling : Yes Is Question Mandatory : No

Correct Marks : 4 Wrong Marks : 1

For changing the capacitance of a given parallel plate capacitor, a dielectric material of dielectric constant K is used, which has the same area as the plates of the capacitor. The thickness of the dielectric slab is $\frac{3}{4}d$, where 'd' is the separation between the plates of parallel plate capacitor. The new capacitance (C') in terms of original capacitance (C₀) is given by the following relation :

Options :

8643519. $C' = \frac{4K}{K+3}C_0$

86435110. $C' = \frac{4}{3+K}C_0$

86435111. $C' = \frac{3+K}{4K}C_0$

86435112. $C' = \frac{4+K}{3}C_0$

Question Number : 3 Question Id : 8643513 Question Type : MCQ Option Shuffling : Yes Is Question Mandatory : No

Correct Marks : 4 Wrong Marks : 1

পৰাবৈদ্যুতিক ফ্ৰেক K ৰ এক পৰাবৈদ্যুতিক পদাৰ্থক, যাৰ ধাৰকৰ পাতৰ সৈতে একেই কালি আছে, এটা সমান্তৰাল পাত ধাৰকৰ ধাৰকত্ব সলনি কৰিবৰ বাবে ব্যৱহাৰ কৰা হৈছে। পৰাবৈদ্যুতিক পাতছটাৰ বেধ $\frac{3}{4}d$, য'ত 'd' সমান্তৰাল পাত ধাৰকৰ পাত দুখনৰ মাজৰ ব্যৱধান। প্ৰাৰম্ভিক ধাৰকত্ব (C_0) ৰ পৰিপ্ৰেক্ষিতত নতুন ধাৰকত্ব (C') তলৰ সম্বন্ধৰ দ্বাৰা দিয়া হৈছে :

Options :

8643519. $C' = \frac{4K}{K+3}C_0$

86435110. $C' = \frac{4}{3+K}C_0$

86435111. $C' = \frac{3+K}{4K}C_0$

86435112. $C' = \frac{4+K}{3}C_0$

Question Number : 4 Question Id : 8643514 Question Type : MCQ Option Shuffling : Yes Is Question Mandatory : No

Correct Marks : 4 Wrong Marks : 1

The velocity-displacement graph describing the motion of a bicycle is shown in the figure.

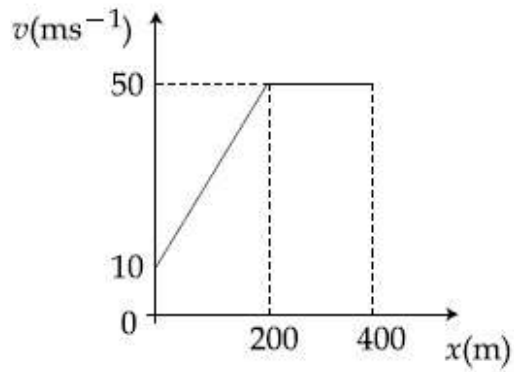

The acceleration-displacement graph of the bicycle's motion is best described by :

Options :

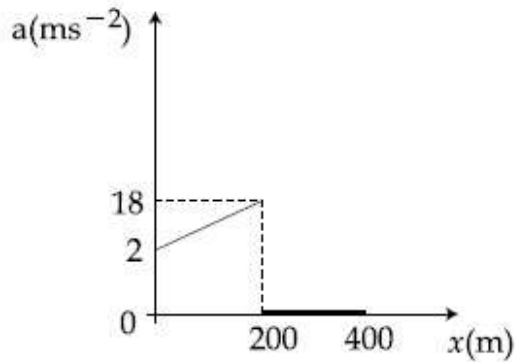

86435113.

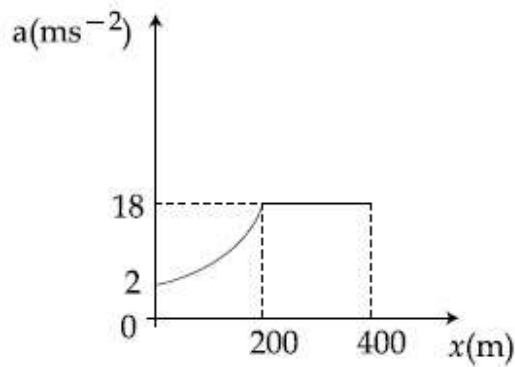

86435114.

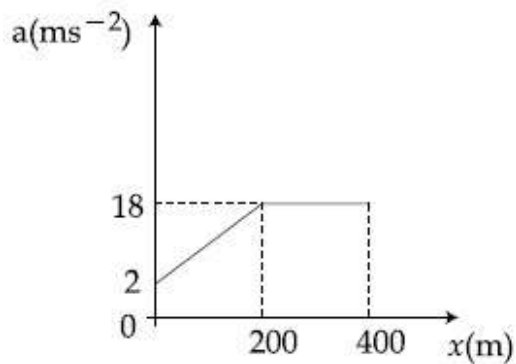

86435115.

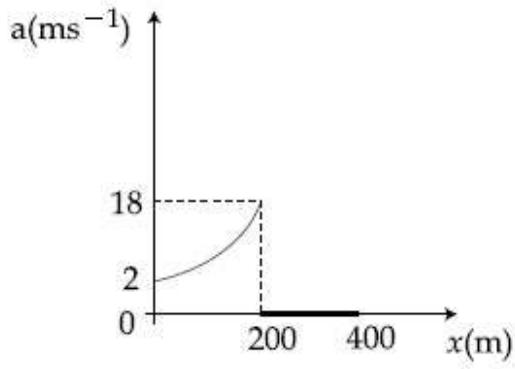

86435116.

Question Number : 4 Question Id : 8643514 Question Type : MCQ Option Shuffling : Yes Is Question Mandatory : No

Correct Marks : 4 Wrong Marks : 1

চিত্রত এখন চাইকেলৰ গতি ব্যাখ্যা কৰা বেগ-সৰণৰ বেখাচিত্ৰ দেখুওৱা হৈছে।

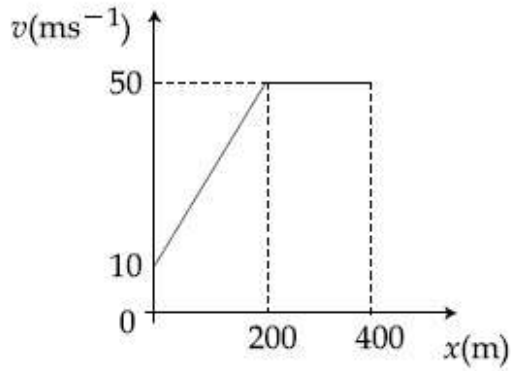

চাইকেলৰ গতিৰ ত্বৰণ-সৰণ বেখাচিত্ৰক সৰ্বোত্তমৰূপে তলৰ কোনটোৱে ব্যাখ্যা কৰিছে :

Options :

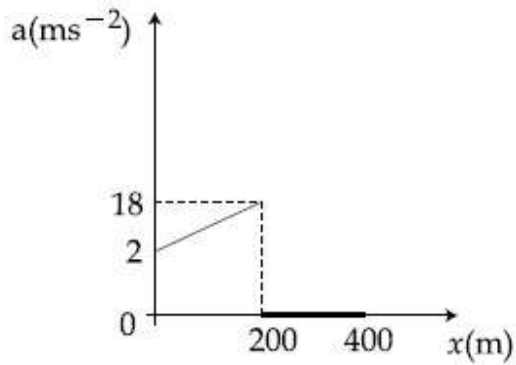

86435113.

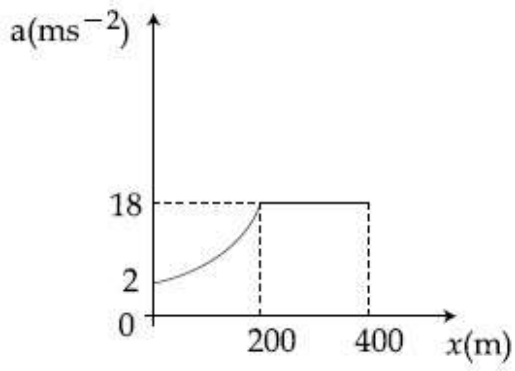

86435114.

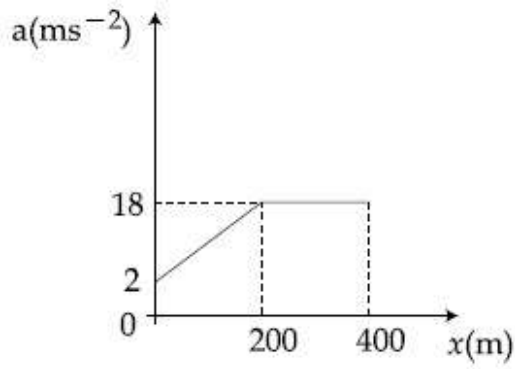

86435115.

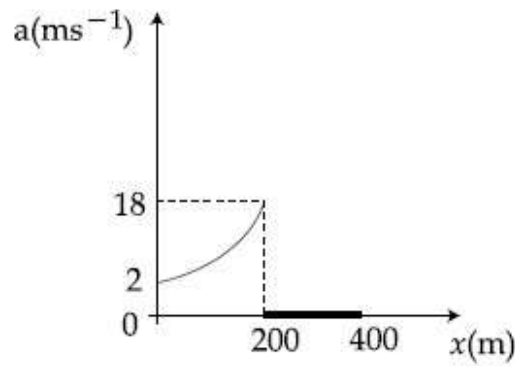

86435116.

Question Number : 5 Question Id : 8643515 Question Type : MCQ Option Shuffling : Yes Is Question Mandatory : No Correct Marks : 4 Wrong Marks : 1

A block of mass m slides along a floor while a force of magnitude F is applied to it at an angle θ as shown in figure. The coefficient of kinetic friction is μ_K . Then, the block's acceleration 'a' is given by :

(g is acceleration due to gravity)

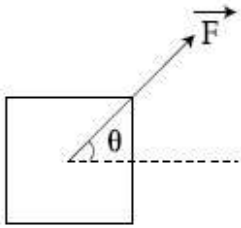

Options :

86435117. $-\frac{F}{m}\cos\theta - \mu_K\left(g - \frac{F}{m}\sin\theta\right)$

86435118. $\frac{F}{m}\cos\theta + \mu_K\left(g - \frac{F}{m}\sin\theta\right)$

86435119. $\frac{F}{m}\cos\theta - \mu_K\left(g + \frac{F}{m}\sin\theta\right)$

86435120. $\frac{F}{m}\cos\theta - \mu_K\left(g - \frac{F}{m}\sin\theta\right)$

Question Number : 5 Question Id : 8643515 Question Type : MCQ Option Shuffling : Yes Is Question Mandatory : No

Correct Marks : 4 Wrong Marks : 1

চিত্ৰত দেখুওৱা ধৰণে, m ভৰৰ এটা ব্লক এখন ফ্ল'ৰত ফ্ল'ৰৰ দিশত চলি যায় যেতিয়া F মানৰ এটা বল ইয়াৰ ওপৰত θ কোণত প্ৰয়োগ কৰা হয়। গতি ঘৰ্ষণৰ গুণাংক হয় μ_K । তেন্তে, ব্লকটোৰ ত্বৰণ 'a' হ'ব :

(g মাধ্যাকৰ্ষণিক ত্বৰণ)

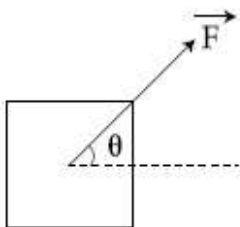

Options :

86435117. $-\frac{F}{m}\cos\theta - \mu_K\left(g - \frac{F}{m}\sin\theta\right)$

86435118. $\frac{F}{m}\cos\theta + \mu_K\left(g - \frac{F}{m}\sin\theta\right)$

86435119. $\frac{F}{m}\cos\theta - \mu_K\left(g + \frac{F}{m}\sin\theta\right)$

86435120. $\frac{F}{m}\cos\theta - \mu_K\left(g - \frac{F}{m}\sin\theta\right)$

Question Number : 6 Question Id : 8643516 Question Type : MCQ Option Shuffling : Yes Is Question Mandatory : No

Correct Marks : 4 Wrong Marks : 1

A bar magnet of length 14 cm is placed in the magnetic meridian with its north pole pointing towards the geographic north pole. A neutral point is obtained at a distance of 18 cm from the center of the magnet. If $B_H = 0.4$ G, the magnetic moment of the magnet is ($1 \text{ G} = 10^{-4}\text{T}$)

Options :

86435121. 28.80 J T^{-1}

86435122. $2.880 \times 10^2 \text{ J T}^{-1}$

86435123. 2.880 J T^{-1}

86435124. $2.880 \times 10^3 \text{ J T}^{-1}$

Question Number : 6 Question Id : 8643516 Question Type : MCQ Option Shuffling : Yes Is Question Mandatory : No

Correct Marks : 4 Wrong Marks : 1

14 cm দৈৰ্ঘ্যৰ এডাল দণ্ড চুম্বকক ইয়াৰ উত্তৰ মেৰু ভৌগলিক উত্তৰ মেৰুৰ দিশত মূৰ কৰি থকাৰৈ চৌম্বকীয় মধ্যাহ্নৰেখাত (meridian) ৰখা হৈছে। চুম্বক ডালৰ কেন্দ্ৰৰ পৰা 18 cm দূৰত্বত এটা নিৰপেক্ষ বিন্দু পোৱা গ'ল। যদি $B_H = 0.4$ G হয়, দণ্ডচুম্বকৰ চৌম্বক ভ্ৰামক হয়, ($1 \text{ G} = 10^{-4}\text{T}$)

Options :

86435121. 28.80 J T^{-1}

86435122. $2.880 \times 10^2 \text{ J T}^{-1}$

86435123. 2.880 J T^{-1}

86435124. $2.880 \times 10^3 \text{ J T}^{-1}$

Question Number : 7 Question Id : 8643517 Question Type : MCQ Option Shuffling : Yes Is Question Mandatory : No

Correct Marks : 4 Wrong Marks : 1

The angle of deviation through a prism is minimum when

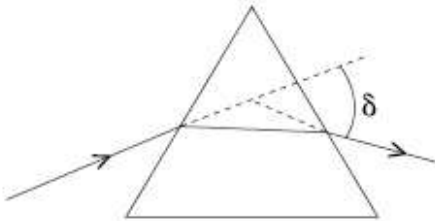

- (A) Incident ray and emergent ray are symmetric to the prism
- (B) The refracted ray inside the prism becomes parallel to its base
- (C) Angle of incidence is equal to that of the angle of emergence
- (D) When angle of emergence is double the angle of incidence

Choose the correct answer from the options given below :

Options :

86435125. Only statements (A) and (B) are true

86435126. Statements (A), (B) and (C) are true

86435127. Only statement (D) is true

86435128. Statements (B) and (C) are true

Question Number : 7 Question Id : 8643517 Question Type : MCQ Option Shuffling : Yes Is Question Mandatory : No

Correct Marks : 4 Wrong Marks : 1

এটা প্ৰিজমৰ মাজেদি বিচ্যুতি কোণ সৰ্বনিম্ন হয় যেতিয়া,

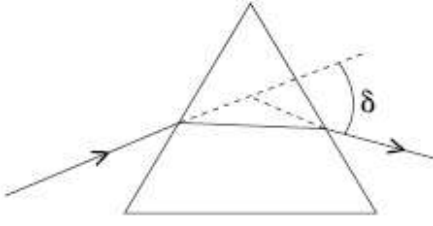

- (A) আপতিত বশ্মি আৰু নিৰ্গত বশ্মি প্ৰিজমৰ সৈতে সমমিত হয়।
(B) প্ৰিজমৰ ভিতৰৰ প্ৰতিসৰিত বশ্মি প্ৰিজমৰ ভূমিৰ সমান্তৰাল হয়।
(C) আপতন কোণ নিৰ্গমন কোণৰ সমান হয়।
(D) যেতিয়া নিৰ্গমন কোণ আপতন কোণৰ দুগুণ হয়।

তলৰ বিকল্পৰ পৰা শুদ্ধ উত্তৰ চয়ন কৰা :

Options :

86435125. কেৱল উক্তি (A) আৰু (B) সঁচা।

86435126. উক্তি (A), (B) আৰু (C) সঁচা।

86435127. কেৱল উক্তি (D) সঁচা।

86435128. উক্তি (B) আৰু (C) সঁচা।

Question Number : 8 Question Id : 8643518 Question Type : MCQ Option Shuffling : Yes Is Question Mandatory : No

Correct Marks : 4 Wrong Marks : 1

An RC circuit as shown in the figure is driven by a AC source generating a square wave. The output wave pattern monitored by CRO would look close to :

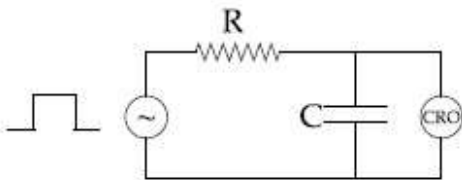

Options :

86435129.

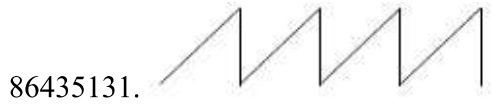
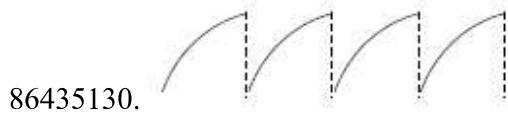

Question Number : 8 Question Id : 8643518 Question Type : MCQ Option Shuffling : Yes Is Question Mandatory : No

Correct Marks : 4 Wrong Marks : 1

বর্গ তরঙ্গ উৎপন্ন করা এটা পরিবর্তী প্রবাহ উৎসের দ্বারা চিত্রিত দেখুওরা ধরণে এটা RC বর্তনী চলোৱা হৈছে। CRO ব দ্বারা নিৰীক্ষণ কৰা আউটপুট তৰংগ প্ৰকাৰ প্ৰায় একে দেখা যাব :

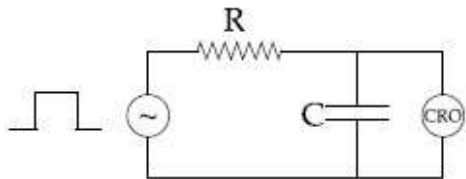

Options :

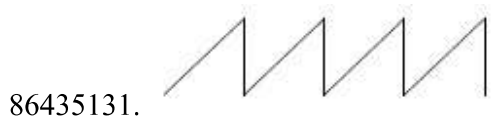
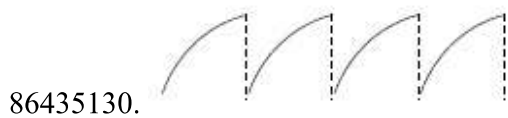
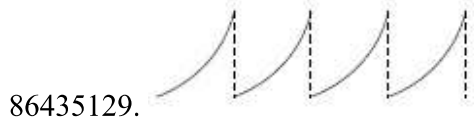

Question Number : 9 Question Id : 8643519 Question Type : MCQ Option Shuffling : Yes Is Question Mandatory : No

Correct Marks : 4 Wrong Marks : 1

A block of 200 g mass moves with a uniform speed in a horizontal circular groove, with vertical side walls of radius 20 cm. If the block takes 40 s to complete one round, the normal force by the side walls of the groove is :

Options :

86435133. 0.0314 N

86435134. 9.859×10^{-4} N

86435135. 6.28×10^{-3} N

86435136. 9.859×10^{-2} N

Question Number : 9 Question Id : 8643519 Question Type : MCQ Option Shuffling : Yes Is Question Mandatory : No

Correct Marks : 4 Wrong Marks : 1

20 cm ব্যাসার্ধৰ উলম্বিক পাৰ্শ্বৰালৰ সৈতে এটা আনুভূমিক বৃত্তাকাৰ খাঁজত সুষ্ম দ্ৰুতিৰে 200 g ভৰৰ এটা ব্লকে গতি কৰিছে। যদিহে এটা চক্ৰ সম্পূৰ্ণ কৰিবৰ বাবে ব্লকটোৱে 40 s সময় লয়, খাঁজটোৰ পাৰ্শ্বৰালসমূহে দিয়া অভিলম্বীয় বল হয় :

Options :

86435133. 0.0314 N

86435134. 9.859×10^{-4} N

86435135. 6.28×10^{-3} N

86435136. 9.859×10^{-2} N

Question Number : 10 Question Id : 86435110 Question Type : MCQ Option Shuffling : Yes Is Question Mandatory : No

Correct Marks : 4 Wrong Marks : 1

In thermodynamics, heat and work are :

Options :

86435137. Point functions

86435138. Path functions

86435139. Intensive thermodynamic state variables

86435140. Extensive thermodynamic state variables

Question Number : 10 Question Id : 86435110 Question Type : MCQ Option Shuffling : Yes Is Question Mandatory : No

Correct Marks : 4 Wrong Marks : 1

তাপ গতি বিজ্ঞানত, তাপ আৰু কাৰ্যা :

Options :

86435137. বিন্দু ফলন

86435138. পথ ফলন

86435139. তীব্র (Intensive) তাপগতিভিত্তিক অৱস্থাসূচক চলক

86435140. বিস্তৃত (Extensive) তাপগতিভিত্তিক অৱস্থাসূচক চলক

Question Number : 11 Question Id : 86435111 Question Type : MCQ Option Shuffling : Yes Is Question Mandatory : No

Correct Marks : 4 Wrong Marks : 1

The maximum and minimum distances of a comet from the Sun are 1.6×10^{12} m and 8.0×10^{10} m respectively. If the speed of the comet at the nearest point is 6×10^4 ms⁻¹, the speed at the farthest point is :

Options :

86435141. 1.5×10^3 m/s

86435142. 3.0×10^3 m/s

86435143. 6.0×10^3 m/s

86435144. 4.5×10^3 m/s

Question Number : 11 Question Id : 86435111 Question Type : MCQ Option Shuffling : Yes Is Question Mandatory : No

Correct Marks : 4 Wrong Marks : 1

সূৰ্য্যৰ পৰা এটা ধূমকেতুৰ সৰ্বোচ্চ আৰু সৰ্বনিম্ন দূৰত্ব ক্ৰমে 1.6×10^{12} m আৰু 8.0×10^{10} m । যদিহে নিকটতম বিন্দুটোত ধূমকেতুটোৰ দ্ৰুতি $6 \times 10^4 \text{ ms}^{-1}$ হয়, সৰ্বোচ্চ দূৰত্বৰ বিন্দুটোত দ্ৰুতি হয় :

Options :

86435141. $1.5 \times 10^3 \text{ m/s}$

86435142. $3.0 \times 10^3 \text{ m/s}$

86435143. $6.0 \times 10^3 \text{ m/s}$

86435144. $4.5 \times 10^3 \text{ m/s}$

Question Number : 12 Question Id : 86435112 Question Type : MCQ Option Shuffling : Yes Is Question Mandatory : No

Correct Marks : 4 Wrong Marks : 1

Four equal masses, m each are placed at the corners of a square of length (l) as shown in the figure. The moment of inertia of the system about an axis passing through A and parallel to DB would be :

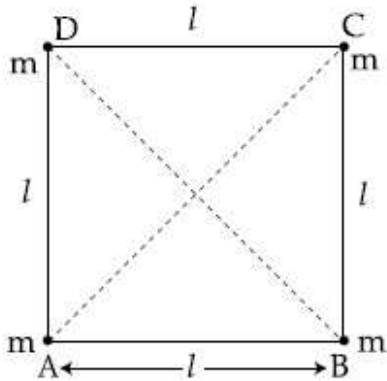

Options :

86435145. $2 ml^2$

86435146. $\sqrt{3} ml^2$

86435147. $3 ml^2$

86435148. ml^2

Question Number : 12 Question Id : 86435112 Question Type : MCQ Option Shuffling : Yes Is Question Mandatory : No

Correct Marks : 4 Wrong Marks : 1

চিত্রত দেখুওৱা ধৰণে, (l) দৈৰ্ঘ্যৰ এটা বৰ্গৰ চুকসমূহত চাৰিটা সমান ভৰ m ৰখা হৈছে। A ৰ মাজেদি যোৱা আৰু DB ৰ সমান্তৰাল এডাল অক্ষ সাপেক্ষে এই নিকায়টোৰ জড় ভ্ৰামক হ'ব :

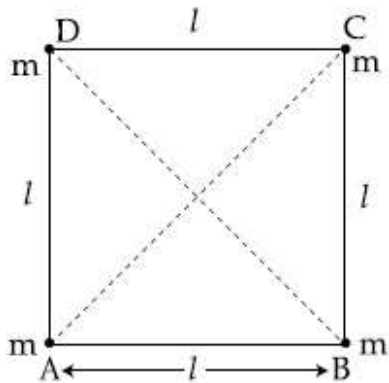

Options :

86435145. $2 ml^2$

86435146. $\sqrt{3} ml^2$

86435147. $3 ml^2$

86435148. ml^2

Question Number : 13 Question Id : 86435113 Question Type : MCQ Option Shuffling : Yes Is Question Mandatory : No

Correct Marks : 4 Wrong Marks : 1

A 25 m long antenna is mounted on an antenna tower. The height of the antenna tower is 75 m. The wavelength (in meter) of the signal transmitted by this antenna would be :

Options :

86435149. 200

86435150. 300

86435151. 400

86435152. 100

Question Number : 13 Question Id : 86435113 Question Type : MCQ Option Shuffling : Yes Is Question Mandatory : No

Correct Marks : 4 Wrong Marks : 1

এক এণ্টেনা স্তম্ভত 25 m দীঘল এডাল এণ্টেনা আৰোহণ কৰোৱা হৈছে। এণ্টেনা স্তম্ভটোৰ উচ্চতা হয় 75 m। এই এণ্টেনাডালে প্ৰেৰণ কৰা সংকেতৰ তৰংগদৈৰ্ঘ্য (meter এককত) হ'ব :

Options :

86435149. 200

86435150. 300

86435151. 400

86435152. 100

Question Number : 14 Question Id : 86435114 Question Type : MCQ Option Shuffling : Yes Is Question Mandatory : No

Correct Marks : 4 Wrong Marks : 1

The stopping potential in the context of photoelectric effect depends on the following property of incident electromagnetic radiation :

Options :

86435153. Frequency

86435154. Amplitude

86435155. Intensity

86435156. Phase

Question Number : 14 Question Id : 86435114 Question Type : MCQ Option Shuffling : Yes Is Question Mandatory : No

Correct Marks : 4 Wrong Marks : 1

আলোক-বৈদ্যুতিক প্ৰভাৱৰ সংক্ৰান্তত প্ৰতিবন্ধক-বিভৰ আপতিত বিদ্যুৎ-চুম্বকীয় তৰংগৰ নিম্নোক্ত ধৰ্মৰ ওপৰত নিৰ্ভৰ কৰে :

Options :

86435153. কম্পনাংক

86435154. বিস্তাৰ

86435155. প্রাৰল্যা

86435156. দশা

Question Number : 15 Question Id : 86435115 Question Type : MCQ Option Shuffling : Yes Is Question Mandatory : No

Correct Marks : 4 Wrong Marks : 1

Time period of a simple pendulum is T inside a lift when the lift is stationary. If the lift moves upwards with an acceleration $g/2$, the time period of pendulum will be :

Options :

86435157. $\frac{T}{\sqrt{3}}$

86435158. $\sqrt{3}T$

86435159. $\sqrt{\frac{3}{2}} T$

86435160. $\sqrt{\frac{2}{3}} T$

Question Number : 15 Question Id : 86435115 Question Type : MCQ Option Shuffling : Yes Is Question Mandatory : No

Correct Marks : 4 Wrong Marks : 1

এটা লিফ্টৰ ভিতৰত থকা এটা সৰল দোলকৰ পৰ্যায়কাল লিফ্টটোৰ স্থিৰ অৱস্থাত T হয়। যদিহে লিফ্টটো $g/2$ ত্বৰণেৰে উৰ্ধমুখে গতি কৰে, দোলকটোৰ পৰ্যায়কাল হ'ব :

Options :

86435157. $\frac{T}{\sqrt{3}}$

86435158. $\sqrt{3}T$

86435159. $\sqrt{\frac{3}{2}} T$

86435160. $\sqrt{\frac{2}{3}} T$

Question Number : 16 Question Id : 86435116 Question Type : MCQ Option Shuffling : Yes Is Question Mandatory : No

Correct Marks : 4 Wrong Marks : 1

A plane electromagnetic wave of frequency 500 MHz is travelling in vacuum along y -direction.

At a particular point in space and time, $\vec{B} = 8.0 \times 10^{-8} \hat{z} T$. The value of electric field at this point is :

(speed of light = $3 \times 10^8 \text{ ms}^{-1}$)

\hat{x} , \hat{y} , \hat{z} are unit vectors along x , y and z directions.

Options :

86435161. $-24 \hat{x} \text{ V/m}$

86435162. $2.6 \hat{x} \text{ V/m}$

86435163. $24 \hat{x} \text{ V/m}$

86435164. $-2.6 \hat{y} \text{ V/m}$

Question Number : 16 Question Id : 86435116 Question Type : MCQ Option Shuffling : Yes Is Question Mandatory : No

Correct Marks : 4 Wrong Marks : 1

y -দিশত শূন্যস্থানত 500 MHz কম্পনাংকৰ এটা বিদ্যুৎ চুম্বকীয় তৰংগই গতি কৰি আছে। মহাকাশ আৰু সময়ৰ এক

বিশেষ বিন্দুত $\vec{B} = 8.0 \times 10^{-8} \hat{z} T$ । এই অৱস্থানত বিন্দুত বৈদ্যুতিক ক্ষেত্ৰৰ মান হয় :

(পোহৰৰ দ্ৰুতি = $3 \times 10^8 \text{ ms}^{-1}$)

\hat{x} , \hat{y} , \hat{z} ক্ৰমে x , y আৰু z অক্ষৰ দিশত একক ভেক্টৰ।

Options :

$-24 \hat{x} \text{ V/m}$

86435161.

86435162. $2.6 \hat{x}$ V/m

86435163. $24 \hat{x}$ V/m

86435164. $-2.6 \hat{y}$ V/m

Question Number : 17 Question Id : 86435117 Question Type : MCQ Option Shuffling : Yes Is Question Mandatory : No

Correct Marks : 4 Wrong Marks : 1

A conducting bar of length L is free to slide on two parallel conducting rails as shown in the figure

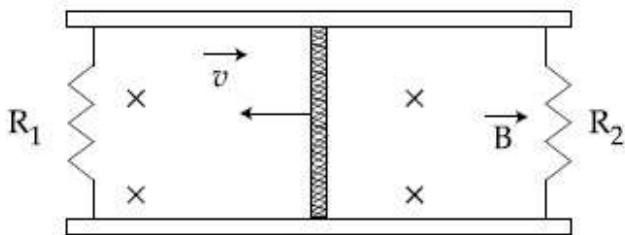

Two resistors R_1 and R_2 are connected across the ends of the rails. There is a uniform magnetic field \vec{B} pointing into the page. An external agent pulls the bar to the left at a constant speed v .

The correct statement about the directions of induced currents I_1 and I_2 flowing through R_1 and R_2 respectively is :

Options :

86435165. I_1 is in anticlockwise direction and I_2 is in clockwise direction

86435166. I_1 is in clockwise direction and I_2 is in anticlockwise direction

86435167. Both I_1 and I_2 are in anticlockwise direction

86435168. Both I_1 and I_2 are in clockwise direction

Question Number : 17 Question Id : 86435117 Question Type : MCQ Option Shuffling : Yes Is Question Mandatory : No

Correct Marks : 4 Wrong Marks : 1

চিত্রত দেখুওৱা ধৰণে, L দৈৰ্ঘ্যৰ এডাল পৰিবাহী দণ্ডই দুডাল সমান্তৰাল পৰিবাহী পটিৰ ওপৰত মুক্তভাৱে চলাচল কৰিব পাৰে।

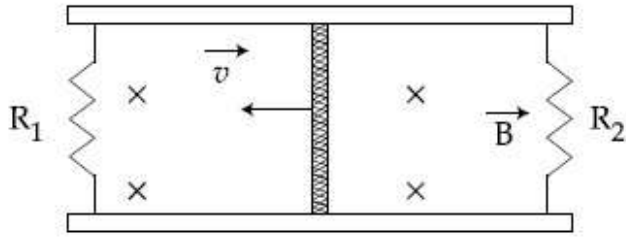

পটিদুডালৰ প্ৰান্তবিন্দু সমূহৰ মাজত দুটা বোধক R_1 আৰু R_2 সংযোগ কৰা হৈছে। পৃষ্ঠাৰ ভিতৰলৈ দিশ কৰি এখন সুসম

চৌম্বিক ক্ষেত্ৰ \vec{B} আছে। এটা বাহ্যিক কাৰকে দণ্ডডালক বাওঁফালে ধ্ৰুৱক দ্ৰুতি v বে টানিছে।

ক্ৰমে R_1 আৰু R_2 ৰ মাজেৰে প্ৰৱাহিত আৱেশিত প্ৰবাহ I_1 আৰু I_2 ৰ দিশ সম্পৰ্কে শুদ্ধ বিবৃতি হ'ব :

Options :

86435165. I_1 ঘড়ীৰ কাঁটাৰ বিপৰীত দিশত আৰু I_2 ঘড়ীৰ কাঁটাৰ দিশত

86435166. I_1 ঘড়ীৰ কাঁটাৰ দিশত আৰু I_2 ঘড়ীৰ কাঁটাৰ বিপৰীত দিশত

86435167. I_1 আৰু I_2 দুয়ো ঘড়ীৰ কাঁটাৰ বিপৰীত দিশত

86435168. I_1 আৰু I_2 দুয়োটাই ঘড়ীৰ কাঁটাৰ দিশত

Question Number : 18 Question Id : 86435118 Question Type : MCQ Option Shuffling : Yes Is Question Mandatory : No

Correct Marks : 4 Wrong Marks : 1

The pressure acting on a submarine is 3×10^5 Pa at a certain depth. If the depth is doubled, the percentage increase in the pressure acting on the submarine would be :

(Assume that atmospheric pressure is 1×10^5 Pa density of water is 10^3 kg m⁻³, $g = 10$ ms⁻²)

Options :

86435169. $\frac{5}{200}\%$

86435170. $\frac{200}{5}\%$

86435171. $\frac{200}{3}\%$

86435172. $\frac{3}{200}\%$

Question Number : 18 Question Id : 86435118 Question Type : MCQ Option Shuffling : Yes Is Question Mandatory : No

Correct Marks : 4 Wrong Marks : 1

এক নির্দিষ্ট গভীরতাত এখন চাবমেৰিণৰ ওপৰত ত্ৰিঘাশীল চাপ হয় 3×10^5 Pa। যদিহে গভীরতা দুগুণ কৰা হয়, চাবমেৰিণৰ ওপৰত ত্ৰিঘাশীল চাপৰ শতকৰা বৃদ্ধি হ'ব :

(ধৰি লোৱা যে বায়ুমণ্ডলীয় চাপ 1×10^5 Pa, পানীৰ ঘনত্ব 10^3 kg m⁻³, $g = 10$ ms⁻²)

Options :

86435169. $\frac{5}{200}\%$

86435170. $\frac{200}{5}\%$

86435171. $\frac{200}{3}\%$

86435172. $\frac{3}{200}\%$

Question Number : 19 Question Id : 86435119 Question Type : MCQ Option Shuffling : Yes Is Question Mandatory : No

Correct Marks : 4 Wrong Marks : 1

A conducting wire of length ' l ', area of cross-section A and electric resistivity ρ is connected between the terminals of a battery. A potential difference V is developed between its ends, causing an electric current.

If the length of the wire of the same material is doubled and the area of cross-section is halved, the resultant current would be :

Options :

86435173. $4 \frac{VA}{\rho l}$

86435174. $\frac{1}{4} \frac{\rho l}{VA}$

86435175. $\frac{1}{4} \frac{VA}{\rho l}$

86435176. $\frac{3}{4} \frac{VA}{\rho l}$

Question Number : 19 Question Id : 86435119 Question Type : MCQ Option Shuffling : Yes Is Question Mandatory : No

Correct Marks : 4 Wrong Marks : 1

এটা বেট্ৰীৰ দুই প্ৰান্তৰ মাজত, বৈদ্যুতিক ৰোধকতা ρ , পৃষ্ঠক্ষেত্ৰৰ কালি A আৰু l দৈৰ্ঘ্যৰ এডাল পৰিবাহী তাঁৰ সংযোগ কৰা হ'ল। ইয়াৰ প্ৰান্তবিন্দুটোৰ মাজত V বিভৱান্তৰ বিকশিত হৈছে, যিয়ে এক বৈদ্যুতিক প্ৰবাহ ঘটাইছে।

যদিহে একেই পদাৰ্থৰ তাঁৰ ডালৰ দৈৰ্ঘ্য দুগুণ কৰা হয় আৰু পৃষ্ঠক্ষেত্ৰৰ কালি আধা কৰা হয়, পৰিণামী প্ৰবাহ হ'ব :

Options :

86435173. $4 \frac{VA}{\rho l}$

86435174. $\frac{1}{4} \frac{\rho l}{VA}$

86435175. $\frac{1}{4} \frac{VA}{\rho l}$

86435176. $\frac{3}{4} \frac{VA}{\rho l}$

Question Number : 20 Question Id : 86435120 Question Type : MCQ Option Shuffling : Yes Is Question Mandatory : No

Correct Marks : 4 Wrong Marks : 1

One main scale division of a vernier callipers is 'a' cm and n^{th} division of the vernier scale coincide with $(n-1)^{\text{th}}$ division of the main scale. The least count of the callipers in mm is :

Options :

86435177. $\left(\frac{n-1}{10n}\right)a$

86435178. $\frac{10 na}{(n - 1)}$

86435179. $\frac{10 a}{n}$

86435180. $\frac{10 a}{(n - 1)}$

Question Number : 20 Question Id : 86435120 Question Type : MCQ Option Shuffling : Yes Is Question Mandatory : No

Correct Marks : 4 Wrong Marks : 1

এডাল ভাৰ্ণিয়াৰ কেলিপাৰৰ মুখ্য স্কেলৰ এক বিভাজন 'a'cm আৰু ভাৰ্ণিয়াৰ স্কেলৰ n তম বিভাজন মুখ্যস্কেলৰ (n-1) তম বিভাজনৰ সৈতে মিলিত হৈছে। কেলিপাৰডালৰ নিম্নতম গণনা mm এককত হয় :

Options :

86435177. $\left(\frac{n - 1}{10 n}\right)a$

86435178. $\frac{10 na}{(n - 1)}$

86435179. $\frac{10 a}{n}$

86435180. $\frac{10 a}{(n - 1)}$

Physics Section B

Section Id :	8643512
Section Number :	2
Section type :	Online
Mandatory or Optional :	Mandatory
Number of Questions :	10
Number of Questions to be attempted :	5
Section Marks :	20
Mark As Answered Required? :	Yes

Sub-Section Number : 1
Sub-Section Id : 8643512
Question Shuffling Allowed : Yes

Question Number : 21 Question Id : 86435121 Question Type : SA
Correct Marks : 4 Wrong Marks : 0

A sinusoidal voltage of peak value 250 V is applied to a series LCR circuit, in which $R=8\ \Omega$, $L=24\ \text{mH}$ and $C=60\ \mu\text{F}$. The value of power dissipated at resonant condition is 'x' kW. The value of x to the nearest integer is _____.

Response Type : Numeric
Evaluation Required For SA : Yes
Show Word Count : Yes
Answers Type : Equal
Text Areas : PlainText
Possible Answers :

100

Question Number : 21 Question Id : 86435121 Question Type : SA
Correct Marks : 4 Wrong Marks : 0

সর্বোচ্চ মান 250 V ৰ এক চাইনোচাইডেল বিভৱ এটা শ্ৰেণীবদ্ধ LCR বৰ্তনীত প্ৰয়োগ কৰা হৈছে, য'ত $R=8\ \Omega$, $L=24\ \text{mH}$ আৰু $C=60\ \mu\text{F}$ । অনুনাদী অৱস্থাত ক্ষয় হোৱা শক্তিৰ মান হয় 'x' kW। নিকটতম পূৰ্ণসংখ্যালৈ x ৰ মান হয় _____।

Response Type : Numeric
Evaluation Required For SA : Yes
Show Word Count : Yes
Answers Type : Equal
Text Areas : PlainText
Possible Answers :

100

Question Number : 22 Question Id : 86435122 Question Type : SA
Correct Marks : 4 Wrong Marks : 0

Consider a frame that is made up of two thin massless rods AB and AC as shown in the figure. A vertical force \vec{P} of magnitude 100 N is applied at point A of the frame.

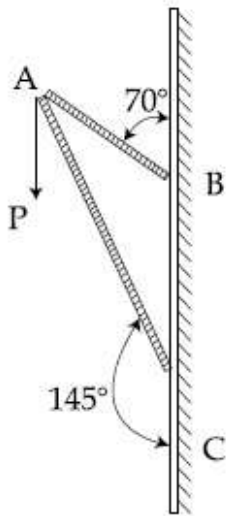

Suppose the force is \vec{P} resolved parallel to the arms AB and AC of the frame.

The magnitude of the resolved component along the arm AC is x N.

The value of x , to the nearest integer, is _____.

[Given : $\sin(35^\circ) = 0.573$, $\cos(35^\circ) = 0.819$

$\sin(110^\circ) = 0.939$, $\cos(110^\circ) = -0.342$]

Response Type : Numeric

Evaluation Required For SA : Yes

Show Word Count : Yes

Answers Type : Equal

Text Areas : PlainText

Possible Answers :

100

Question Number : 22 **Question Id :** 86435122 **Question Type :** SA

Correct Marks : 4 **Wrong Marks :** 0

চিত্রত দেখুওৱা ধৰণে, দুডাল পাতল ভৰহীন দণ্ড AB আৰু AC ৰে বনোৱা এটা ফ্ৰেম বিচাৰ কৰা। ফ্ৰেমটোৰ এটা বিন্দু A ত 100 N মানৰ এটা অভিলম্বিক বল \vec{P} প্ৰয়োগ কৰা হ'ল।

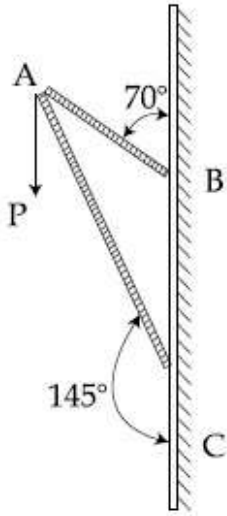

ধৰি লোৱা, \vec{P} বলটো ফ্ৰেমটোৰ বাহু AB আৰু AC ৰ সমান্তৰালকৈ বিয়োজন কৰা হ'ল। AC বাহুৰ দিশত বিয়োজিত অংশটোৰ মান হয় xN ।

নিকটতম পূৰ্ণসংখ্যালৈ x ৰ মান হয় _____।

[দিয়া আছে : $\sin(35^\circ) = 0.573$, $\cos(35^\circ) = 0.819$

$\sin(110^\circ) = 0.939$, $\cos(110^\circ) = -0.342$]

Response Type : Numeric

Evaluation Required For SA : Yes

Show Word Count : Yes

Answers Type : Equal

Text Areas : PlainText

Possible Answers :

100

Question Number : 23 **Question Id :** 86435123 **Question Type :** SA

Correct Marks : 4 **Wrong Marks :** 0

The first three spectral lines of H-atom in the Balmer series are given $\lambda_1, \lambda_2, \lambda_3$ considering the

Bohr atomic model, the wave lengths of first and third spectral lines $\left(\frac{\lambda_1}{\lambda_3}\right)$ are related by a

factor of approximately ' x ' $\times 10^{-1}$.

The value of x , to the nearest integer, is _____.

Response Type : Numeric

Evaluation Required For SA : Yes

Show Word Count : Yes

Answers Type : Equal

Text Areas : PlainText

Possible Answers :

100

Question Number : 23 Question Id : 86435123 Question Type : SA

Correct Marks : 4 Wrong Marks : 0

বামাৰ শ্ৰেণীত H-পৰমাণুৰ প্ৰথম তিনিটা বৰ্ণালী বেখা দিয়া আছে λ_1, λ_2 , আৰু λ_3 । ব'বৰ পৰমাণু আৰ্হি ধৰি, প্ৰথম আৰু

তৃতীয় বেখা বৰ্ণালীৰ তৰংগদৈৰ্ঘ্য $\left(\frac{\lambda_1}{\lambda_3}\right)$ এটা মোটামুটিভাৱে ' x ' $\times 10^{-1}$ ৰ গুণকৰে সম্বন্ধিত।

x ৰ মান, নিকটতম পূৰ্ণসংখ্যালৈ _____।

Response Type : Numeric

Evaluation Required For SA : Yes

Show Word Count : Yes

Answers Type : Equal

Text Areas : PlainText

Possible Answers :

100

Question Number : 24 Question Id : 86435124 Question Type : SA

Correct Marks : 4 Wrong Marks : 0

The value of power dissipated across the zener diode ($V_z = 15$ V) connected in the circuit as shown in the figure is $x \times 10^{-1}$ watt.

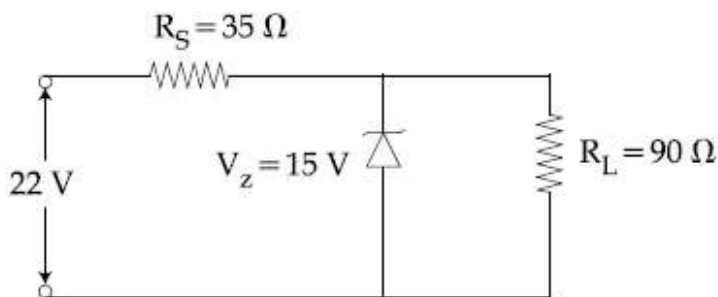

The value of x , to the nearest integer, is _____.

Response Type : Numeric

Evaluation Required For SA : Yes

Show Word Count : Yes

Answers Type : Equal

Text Areas : PlainText

Possible Answers :

100

Question Number : 24 Question Id : 86435124 Question Type : SA

Correct Marks : 4 Wrong Marks : 0

চিত্রত দেখুওৱা দৰে বৰ্তনীত সংযোজিত জেনাৰ ডায়'ডটোৰ ($V_z = 15 \text{ V}$) দুয়োমূৰে অৱক্ষয় হোৱা শক্তিৰ মান হয় $x \times 10^{-1} \text{ watt}$ ।

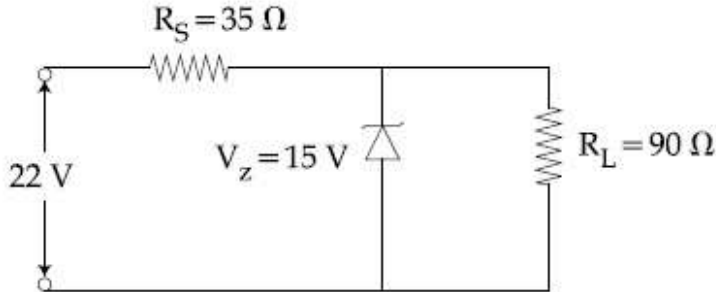

x ৰ মান, নিকটতম পূৰ্ণসংখ্যাতলৈ _____।

Response Type : Numeric

Evaluation Required For SA : Yes

Show Word Count : Yes

Answers Type : Equal

Text Areas : PlainText

Possible Answers :

100

Question Number : 25 Question Id : 86435125 Question Type : SA

Correct Marks : 4 Wrong Marks : 0

A ball of mass 10 kg moving with a velocity $10\sqrt{3} \text{ m s}^{-1}$ along X-axis, hits another ball of mass 20 kg which is at rest. After collision, the first ball comes to rest and the second one disintegrates into two equal pieces. One of the pieces starts moving along Y-axis at a speed of 10 m/s. The second piece starts moving at a speed of 20 m/s at an angle θ (degree) with respect to the X-axis.

The configuration of pieces after collision is shown in the figure.

The value of θ to the nearest integer is _____.

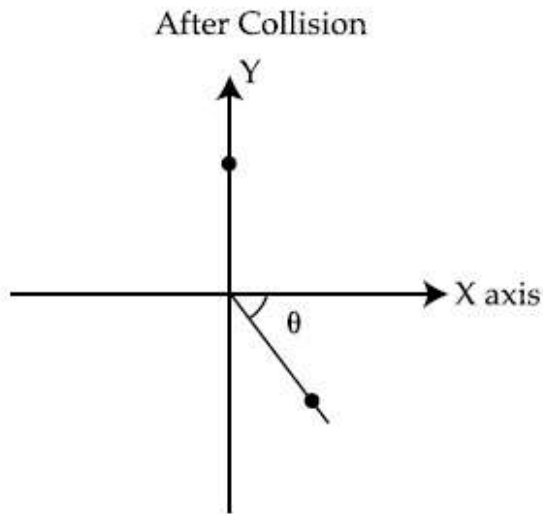

Response Type : Numeric

Evaluation Required For SA : Yes

Show Word Count : Yes

Answers Type : Equal

Text Areas : PlainText

Possible Answers :

100

Question Number : 25 **Question Id :** 86435125 **Question Type :** SA

Correct Marks : 4 **Wrong Marks :** 0

X-অক্ষৰ দিশত $10\sqrt{3} \text{ m s}^{-1}$ বেগেৰে গতি কৰি থকা 10 kg ভৰৰ এটা বল, 20 kg ভৰৰ অন্য এটা ছিৰ অৱস্থাত থকা বলক খুন্দা মাৰিছে। সংঘৰ্ষৰ পাছত, প্ৰথমটো বল ছিৰ অৱস্থালৈ আহে আৰু দ্বিতীয়টো বল দুটা সমান টুকুৰাত ভাঙি যায়। তাৰে এটা টুকুৰাই Y-অক্ষৰ দিশত 10 m/s দ্ৰুতিৰে গতি কৰিবলৈ আৰম্ভ কৰে। দ্বিতীয়টো টুকুৰাই X-অক্ষ অনুযায়ী এক θ (ডিগ্ৰী) কোণত 20 m/s দ্ৰুতিৰে গতি কৰিবলৈ আৰম্ভ কৰে।

চিত্ৰত সংঘৰ্ষৰ পাছত টুকুৰাকেইটাৰ বিন্যাস দেখুওৱা হৈছে।

θ ৰ মান নিকটতম পূৰ্ণসংখ্যালৈ _____।

সংঘৰ্ষৰ পিছত

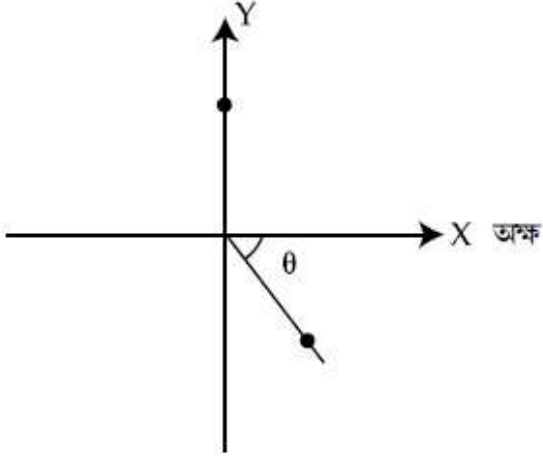

Response Type : Numeric

Evaluation Required For SA : Yes

Show Word Count : Yes

Answers Type : Equal

Text Areas : PlainText

Possible Answers :

100

Question Number : 26 **Question Id :** 86435126 **Question Type :** SA

Correct Marks : 4 **Wrong Marks :** 0

Consider a 20 kg uniform circular disk of radius 0.2 m. It is pin supported at its center and is at rest initially. The disk is acted upon by a constant force $F = 20 \text{ N}$ through a massless string wrapped around its periphery as shown in the figure.

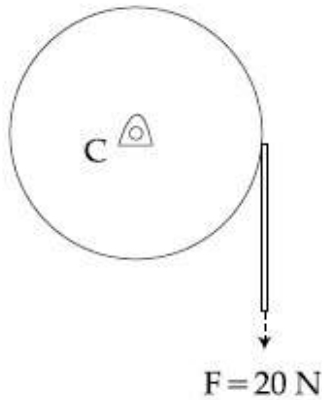

Suppose the disk makes n number of revolutions to attain an angular speed of 50 rad s^{-1} . The value of n , to the nearest integer, is _____.

[Given : In one complete revolution, the disk rotates by 6.28 rad]

Response Type : Numeric

Evaluation Required For SA : Yes

Show Word Count : Yes

Answers Type : Equal

Text Areas : PlainText

Possible Answers :

100

Question Number : 26 **Question Id :** 86435126 **Question Type :** SA

Correct Marks : 4 **Wrong Marks :** 0

0.2 m ব্যাসার্ধৰ 20 kg ৰ এক সুষম বৃত্তাকাৰ থাল বিবেচনা কৰা। ইয়াক ইয়াৰ কেন্দ্ৰত এটা পিনৰ সহায়ত সমর্থন দিয়া হৈছে আৰু আৰম্ভণিতে স্থিৰ অৱস্থাত থাকে। চিত্ৰত দেখুওৱা ধৰণে ইয়াৰ পৰিধিৰ চাৰিওফালে মেৰিওৱা এডাল ভৰহীন স্প্ৰিংৰ যোগেদি এক ধ্ৰুৱক বল $F = 20\text{ N}$ ক থালখনত ক্ৰিয়া কৰোৱা হৈছে।

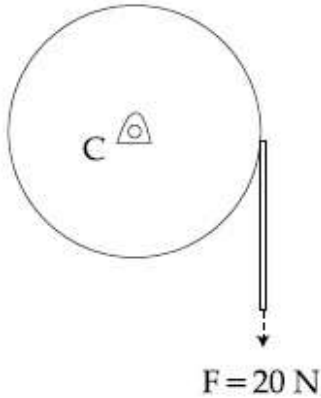

ধৰি লোৱা এক কৌণিক বেগ 50 rad s^{-1} পাবলৈ থালখনে n সংখ্যক পৰিভ্ৰমণ কৰে।

n ৰ মান, নিকটতম পূৰ্ণসংখ্যালৈ _____।

[দিয়া আছে : এক সম্পূৰ্ণ পৰিভ্ৰমণত থালখন 6.28 rad ঘূৰে]

Response Type : Numeric

Evaluation Required For SA : Yes

Show Word Count : Yes

Answers Type : Equal

Text Areas : PlainText

Possible Answers :

100

Question Number : 27 **Question Id :** 86435127 **Question Type :** SA

Correct Marks : 4 **Wrong Marks :** 0

In the logic circuit shown in the figure, if input A and B are 0 to 1 respectively, the output at Y would be 'x'.

The value of x is _____.

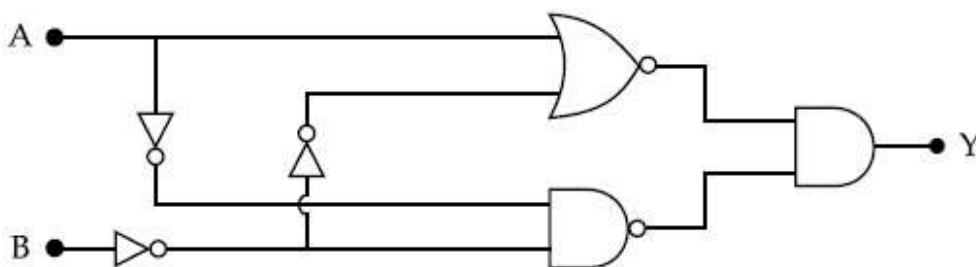

Response Type : Numeric

Evaluation Required For SA : Yes

Show Word Count : Yes

Answers Type : Equal

Text Areas : PlainText

Possible Answers :

100

Question Number : 27 Question Id : 86435127 Question Type : SA

Correct Marks : 4 Wrong Marks : 0

চিত্রত দেখুওৱা লজিক বৰ্তনীটোত, যদিহে ইনপুট A আৰু B ক্ৰমে 0 ৰ পৰা 1 হয়, Y ত আউটপুট হ'ব 'x'।

x ৰ মান _____।

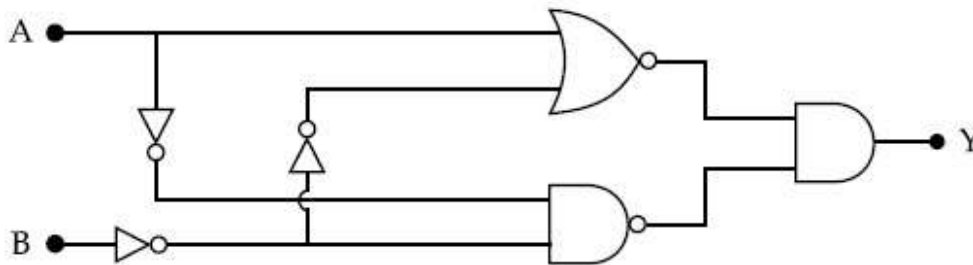

Response Type : Numeric

Evaluation Required For SA : Yes

Show Word Count : Yes

Answers Type : Equal

Text Areas : PlainText

Possible Answers :

100

Question Number : 28 Question Id : 86435128 Question Type : SA

Correct Marks : 4 Wrong Marks : 0

In the figure given, the electric current flowing through the 5 k Ω resistor is 'x' mA.

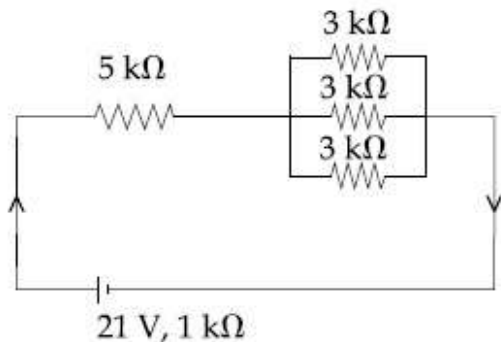

The value of x to the nearest integer is _____.

Response Type : Numeric

Evaluation Required For SA : Yes

Show Word Count : Yes

Answers Type : Equal

Text Areas : PlainText

Possible Answers :

100

Question Number : 28 Question Id : 86435128 Question Type : SA

Correct Marks : 4 Wrong Marks : 0

দিয়া চিত্রত, $5\text{ k}\Omega$ বোধকটোৰ মাজেদি প্ৰবাহিত বৈদ্যুতিক প্ৰবাহ ' x ' mA.

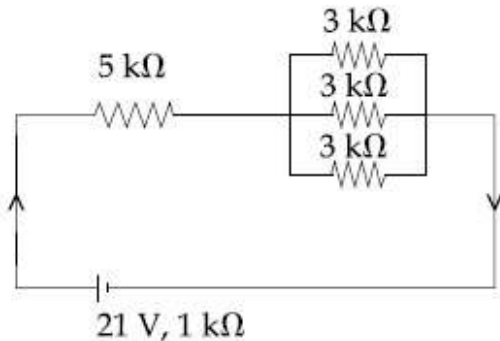

x ৰ মান নিকটতম পূৰ্ণসংখ্যালৈ _____।

Response Type : Numeric

Evaluation Required For SA : Yes

Show Word Count : Yes

Answers Type : Equal

Text Areas : PlainText

Possible Answers :

100

Question Number : 29 Question Id : 86435129 Question Type : SA

Correct Marks : 4 Wrong Marks : 0

A fringe width of 6 mm was produced for two slits separated by 1 mm apart. The screen is placed 10 m away. The wavelength of light used is ' x ' nm.

The value of ' x ' to the nearest integer is _____.

Response Type : Numeric

Evaluation Required For SA : Yes

Show Word Count : Yes

Answers Type : Equal

Text Areas : PlainText

Possible Answers :

100

Question Number : 29 Question Id : 86435129 Question Type : SA

Correct Marks : 4 Wrong Marks : 0

1 mm ব্যৱধানত থকা দুটা ছিদ্ৰৰ বাবে 6 mm পটিবেধৰ উৎপন্ন হয়। পৰ্দাখন 10 m দূৰত্বত ৰখা হৈছে। ব্যৱহাৰ কৰা পোহৰৰ তৰংগদৈৰ্ঘ্য হয় 'x' nm।

'x' ৰ মান নিকটতম পূৰ্ণসংখ্যালৈ _____।

Response Type : Numeric

Evaluation Required For SA : Yes

Show Word Count : Yes

Answers Type : Equal

Text Areas : PlainText

Possible Answers :

100

Question Number : 30 **Question Id :** 86435130 **Question Type :** SA

Correct Marks : 4 **Wrong Marks :** 0

The resistance $R = \frac{V}{I}$, where $V = (50 \pm 2)V$ and $I = (20 \pm 0.2)A$. The percentage error in R is

'x' %.

The value of 'x' to the nearest integer is _____.

Response Type : Numeric

Evaluation Required For SA : Yes

Show Word Count : Yes

Answers Type : Equal

Text Areas : PlainText

Possible Answers :

100

Question Number : 30 **Question Id :** 86435130 **Question Type :** SA

Correct Marks : 4 **Wrong Marks :** 0

বোধ $R = \frac{V}{I}$, য'ত $V = (50 \pm 2)V$ আৰু $I = (20 \pm 0.2)A$ । R ৰ শতকৰা ত্ৰুটি 'x' %।

'x' ৰ মান নিকটতম পূৰ্ণসংখ্যালৈ _____।

Response Type : Numeric

Evaluation Required For SA : Yes

Show Word Count : Yes

Answers Type : Equal

Text Areas : PlainText

Possible Answers :

100

Chemistry Section A

Section Id :	8643513
Section Number :	3
Section type :	Online
Mandatory or Optional :	Mandatory
Number of Questions :	20
Number of Questions to be attempted :	20
Section Marks :	80
Mark As Answered Required? :	Yes
Sub-Section Number :	1
Sub-Section Id :	8643513
Question Shuffling Allowed :	Yes

Question Number : 31 Question Id : 86435131 Question Type : MCQ Option Shuffling : Yes Is Question Mandatory : No

Correct Marks : 4 Wrong Marks : 1

Given below are two statements : one is labelled as Assertion A and the other is labelled as Reason R :

Assertion A : The H – O – H bond angle in water molecule is 104.5° .

Reason R : The lone pair - lone pair repulsion of electrons is higher than the bond pair - bond pair repulsion.

In the light of the above statements, choose the correct answer from the options given below :

Options :

86435191. Both A and R are true, and R is the correct explanation of A

86435192. Both A and R are true, but R is not the correct explanation of A

86435193. A is true but R is false

86435194. A is false but R is true

Question Number : 31 Question Id : 86435131 Question Type : MCQ Option Shuffling : Yes Is Question Mandatory : No

Correct Marks : 4 Wrong Marks : 1

তলত দুটা উক্তি দিয়া হ'ল। এটা কথন A আৰু আনটো কাৰণ R হিচাবে সূচিত কৰা হৈছে।

কথন A : পানীৰ অণুত H-O-H বান্ধনি কোণ হ'ল 104.5° ।

কাৰণ R : একাকী যুগ্ম-একাকী যুগ্ম ইলেক্ট্ৰনৰ বিকৰ্ষণ, বান্ধনী যুগ্ম-বান্ধনী যুগ্ম বিকৰ্ষণতকৈ বেছি।

ওপৰৰ উক্তিৰ আলমত, নিম্নলিখিত বিকল্পবপৰা শুদ্ধ বিকল্প বাছি উলিওৱা :

Options :

86435191. A আৰু R দুয়োটা সত্য আৰু R হ'ল A ৰ শুদ্ধ ব্যাখ্যা।

86435192. A আৰু R দুয়োটা সত্য, কিন্তু R, A ৰ শুদ্ধ ব্যাখ্যা নহয়।

86435193. A সত্য কিন্তু R অসত্য।

86435194. A অসত্য কিন্তু R সত্য।

Question Number : 32 Question Id : 86435132 Question Type : MCQ Option Shuffling : Yes Is Question Mandatory : No

Correct Marks : 4 Wrong Marks : 1

Match List - I with List - II :

List - I	List - II
Industrial process	Application
(a) Haber's process	(i) HNO_3 synthesis
(b) Ostwald's process	(ii) Aluminium extraction
(c) Contact process	(iii) NH_3 synthesis
(d) Hall-Heroult process	(iv) H_2SO_4 synthesis

Choose the correct answer from the options given below :

Options :

86435195. (a)-(iv), (b)-(i), (c)-(ii), (d)-(iii)

86435196. (a)-(iii), (b)-(i), (c)-(iv), (d)-(ii)

86435197. (a)-(ii), (b)-(iii), (c)-(iv), (d)-(i)

86435198. (a)-(iii), (b)-(iv), (c)-(i), (d)-(ii)

Question Number : 32 Question Id : 86435132 Question Type : MCQ Option Shuffling : Yes Is Question Mandatory : No

Correct Marks : 4 Wrong Marks : 1

তালিকা - I ক তালিকা - II ৰ সৈতে মিলন কৰা :

তালিকা - I

তালিকা - II

ঔদ্যোগিক পদ্ধতি

ব্যৱহাৰ

- | | |
|------------------------|---------------------------------------|
| (a) হেবাৰৰ পদ্ধতি | (i) HNO_3 সংশ্লেষণ |
| (b) অ'ষ্টৱাল্ডৰ পদ্ধতি | (ii) এলুমিনিয়াম নিৰ্গত কৰা |
| (c) কণ্টেক্ট পদ্ধতি | (iii) NH_3 সংশ্লেষণ |
| (d) হল-হেব'ল্ট পদ্ধতি | (iv) H_2SO_4 সংশ্লেষণ |

নিম্নলিখিত বিকল্পৰপৰা শুদ্ধ উত্তৰ বাছি উলিওৱা :

Options :

86435195. (a)-(iv), (b)-(i), (c)-(ii), (d)-(iii)

86435196. (a)-(iii), (b)-(i), (c)-(iv), (d)-(ii)

86435197. (a)-(ii), (b)-(iii), (c)-(iv), (d)-(i)

86435198. (a)-(iii), (b)-(iv), (c)-(i), (d)-(ii)

Question Number : 33 Question Id : 86435133 Question Type : MCQ Option Shuffling : Yes Is Question Mandatory : No

Correct Marks : 4 Wrong Marks : 1

A group 15 element, which is a metal and forms a hydride with strongest reducing power among group 15 hydrides. The element is :

Options :

86435199. Bi

864351100. P

864351101. As

864351102. Sb

Question Number : 33 Question Id : 86435133 Question Type : MCQ Option Shuffling : Yes Is Question Mandatory : No

Correct Marks : 4 Wrong Marks : 1

এটা বৰ্গ 15 ৰ মৌল, যি এটা ধাতু আৰু যিয়ে বৰ্গ 15 ৰ হাইড্ৰাইডবোৰৰ ভিতৰত আটাইতকৈ শক্তিশালী বিজাৰণ ক্ষমতা থকা হাইড্ৰাইড বনায়। মৌলটো হ'ল :

Options :

86435199. Bi

864351100. P

864351101. As

864351102. Sb

Question Number : 34 Question Id : 86435134 Question Type : MCQ Option Shuffling : Yes Is Question Mandatory : No

Correct Marks : 4 Wrong Marks : 1

The process that involves the removal of sulphur from the ores is :

Options :

864351103. Refining

864351104. Roasting

864351105. Smelting

864351106. Leaching

Question Number : 34 Question Id : 86435134 Question Type : MCQ Option Shuffling : Yes Is Question Mandatory : No

Correct Marks : 4 Wrong Marks : 1

আকৰিকৰ পৰা ছালফাৰ আঁতৰ কৰাত ব্যৱহাৰ হোৱা পদ্ধতিটো হ'ল :

Options :

864351103. শোধন

864351104. তাপজাৰণ

864351105. বিগলন

864351106. নিষ্কালন

Question Number : 35 Question Id : 86435135 Question Type : MCQ Option Shuffling : Yes Is Question Mandatory : No

Correct Marks : 4 Wrong Marks : 1

Given below are two statements :

Statement I : H_2O_2 can act as both oxidising and reducing agent in basic medium.

Statement II : In the hydrogen economy, the energy is transmitted in the form of dihydrogen.

In the light of the above statements, choose the correct answer from the options given below :

Options :

864351107. Both statement I and statement II are true

864351108. Both statement I and statement II are false

864351109. Statement I is true but statement II is false

864351110. Statement I is false but statement II is true

Question Number : 35 Question Id : 86435135 Question Type : MCQ Option Shuffling : Yes Is Question Mandatory : No

Correct Marks : 4 Wrong Marks : 1

তলত দুটা উক্তি দিয়া আছে।

উক্তি I : H_2O_2 এ ক্ষাৰকীয় মাধ্যমত জাৰণ আৰু বিজাৰণ কৰ্তা দুয়োটা হিচাপে ভূমিকা লব পাৰে।

উক্তি II : হাইড্ৰজেন মিতব্যয়ীতাত, ডাইহাইড্ৰজেনৰ ৰূপত শক্তি প্ৰেৰণ কৰে।

ওপৰৰ উক্তিৰ আলমত, নিম্নলিখিত বিকল্পৰপৰা শুদ্ধ উত্তৰটো বাছি উলিওৱা :

Options :

864351107. উক্তি I আৰু উক্তি II দুয়োটা সত্য

864351108. উক্তি I আৰু উক্তি II দুয়োটা অসত্য

864351109. উক্তি I সত্য কিন্তু উক্তি II অসত্য

864351110. উক্তি I অসত্য কিন্তু উক্তি II সত্য

Question Number : 36 Question Id : 86435136 Question Type : MCQ Option Shuffling : Yes Is Question Mandatory : No

Correct Marks : 4 Wrong Marks : 1

Given below are two statements :

Statement I : Both $\text{CaCl}_2 \cdot 6\text{H}_2\text{O}$ and $\text{MgCl}_2 \cdot 8\text{H}_2\text{O}$ undergo dehydration on heating.

Statement II : BeO is amphoteric whereas the oxides of other elements in the same group are acidic.

In the light of the above statements, choose the correct answer from the options given below :

Options :

864351111. Both statement I and statement II are true

864351112. Both statement I and statement II are false

864351113. Statement I is true but statement II is false

864351114. Statement I is false but statement II is true

Question Number : 36 Question Id : 86435136 Question Type : MCQ Option Shuffling : Yes Is Question Mandatory : No

Correct Marks : 4 Wrong Marks : 1

তলত দুটা উক্তি দিয়া আছে।

উক্তি I : $\text{MgCl}_2 \cdot 8\text{H}_2\text{O}$ আৰু $\text{CaCl}_2 \cdot 6\text{H}_2\text{O}$ দুয়োৰে গৰম কৰিলে নিজলীকৰণ হয়।

উক্তি II : BeO উভয়ধৰ্মী, য'ত একে বৰ্গৰ আন মৌলৰ অক্সাইডবোৰ অম্লীয়।

ওপৰৰ উক্তিৰ আলমত, নিম্নলিখিত বিকল্পবপৰা শুদ্ধ উত্তৰটো বাছি উলিওৱা :

Options :

864351111. উক্তি I আৰু উক্তি II দুয়োটা সত্য

864351112. উক্তি I আৰু উক্তি II দুয়োটা অসত্য

864351113. উক্তি I সত্য কিন্তু উক্তি II অসত্য

864351114. উক্তি I অসত্য কিন্তু উক্তি II সত্য

Question Number : 37 Question Id : 86435137 Question Type : MCQ Option Shuffling : Yes Is Question Mandatory : No

Correct Marks : 4 Wrong Marks : 1

Match List - I with List - II :

List - I	List - II
Name of oxo acid	Oxidation state of 'P'
(a) Hypophosphorous acid	(i) + 5
(b) Orthophosphoric acid	(ii) + 4
(c) Hypophosphoric acid	(iii) + 3
(d) Orthophosphorous acid	(iv) + 2
	(v) + 1

Choose the correct answer from the options given below :

Options :

864351115. (a)-(v), (b)-(iv), (c)-(ii), (d)-(iii)

864351116. (a)-(iv), (b)-(i), (c)-(ii), (d)-(iii)

864351117. (a)-(iv), (b)-(v), (c)-(ii), (d)-(iii)

864351118. (a)-(v), (b)-(i), (c)-(ii), (d)-(iii)

Question Number : 37 Question Id : 86435137 Question Type : MCQ Option Shuffling : Yes Is Question Mandatory : No

Correct Marks : 4 Wrong Marks : 1

তালিকা - I ক তালিকা - II ৰ সৈতে মিলন কৰা :

তালিকা - I	তালিকা - II
অক্স'এছিডৰ নাম	'P' ৰ জাৰণ অৱস্থা
(a) হাইপ'ফছফৰাছ এছিড	(i) +5
(b) অ'ৰ্থ'ফছফৰিক এছিড	(ii) +4
(c) হাইপ'ফছফৰিক এছিড	(iii) +3
(d) অ'ৰ্থ'ফছফৰাছ এছিড	(iv) +2
	(v) +1

নিম্নলিখিত বিকল্পৰ পৰা শুদ্ধ উত্তৰ বাছি উলিওৱা :

Options :

864351115. (a)-(v), (b)-(iv), (c)-(ii), (d)-(iii)

864351116. (a)-(iv), (b)-(i), (c)-(ii), (d)-(iii)

864351117. (a)-(iv), (b)-(v), (c)-(ii), (d)-(iii)

864351118. (a)-(v), (b)-(i), (c)-(ii), (d)-(iii)

Question Number : 38 Question Id : 86435138 Question Type : MCQ Option Shuffling : Yes Is Question Mandatory : No

Correct Marks : 4 Wrong Marks : 1

Given below are two statement : one is labelled as Assertion A and the other is labelled as Reason R :

Assertion A : Size of Bk^{3+} ion is less than Np^{3+} ion.

Reason R : The above is a consequence of the lanthanoid contraction.

In the light of the above statements, choose the correct answer from the options given below :

Options :

864351119. Both A and R are true and R is the correct explanation of A

864351120. Both A and R are true but R is not the correct explanation of A

864351121. A is true but R is false

864351122. A is false but R is true

Question Number : 38 Question Id : 86435138 Question Type : MCQ Option Shuffling : Yes Is Question Mandatory : No

Correct Marks : 4 Wrong Marks : 1

তলত দুটা উক্তি দিয়া হ'ল। এটা নিশ্চয়োক্তি A আৰু আনটো কাৰণ R হিচাবে সূচিত কৰা হ'ল।

নিশ্চয়োক্তি A : Bk^{3+} আয়নৰ আকাৰ Np^{3+} আয়নতকৈ সৰু।

কাৰণ R : ওপৰৰ উক্তিটো এক্টিনয়ড সংকোচনৰ পৰিণাম।

ওপৰৰ উক্তিৰ আলমত, নিম্নলিখিত বিকল্পবপৰা শুদ্ধ উত্তৰ বাছি উলিওৱা :

Options :

864351119. A আৰু R দুয়োটা সত্য আৰু R হ'ল A ৰ শুদ্ধ ব্যাখ্যা।

864351120. A আৰু R দুয়োটা সত্য, কিন্তু R, A ৰ শুদ্ধ ব্যাখ্যা নহয়।

864351121. A সত্য কিন্তু R অসত্য।

864351122. A অসত্য কিন্তু R সত্য।

Question Number : 39 Question Id : 86435139 Question Type : MCQ Option Shuffling : Yes Is Question Mandatory : No

Correct Marks : 4 Wrong Marks : 1

Given below are two statements :

Statement I : The E° value for Ce^{4+}/Ce^{3+} is +1.74 V.

Statement II : Ce is more stable in Ce^{4+} state than Ce^{3+} state.

In the light of the above statements, choose the most appropriate answer from the options given below :

Options :

864351123. Both statement I and statement II are correct

864351124. Both statement I and statement II are incorrect

864351125. Statement I is correct but statement II is incorrect

864351126. Statement I is incorrect but statement II is correct

Question Number : 39 Question Id : 86435139 Question Type : MCQ Option Shuffling : Yes Is Question Mandatory : No

Correct Marks : 4 Wrong Marks : 1

তলত দুটা উক্তি দিয়া হ'ল।

উক্তি I: Ce^{4+}/Ce^{3+} ৰ বাবে E° ৰ মান $+1.74$ V।

উক্তি II: Ce , Ce^{3+} অৱস্থাতকৈ Ce^{4+} অৱস্থাত বেছি সুস্থিৰ।

ওপৰৰ উক্তিৰ আলমত, নিম্নলিখিত বিকল্পবপৰা আটাইতকৈ উপযুক্ত উত্তৰটো বাছি উলিওৱা :

Options :

864351123. উক্তি I আৰু উক্তি II দুয়োটা সত্য

864351124. উক্তি I আৰু উক্তি II দুয়োটা অসত্য

864351125. উক্তি I সত্য কিন্তু উক্তি II অসত্য

864351126. উক্তি I অসত্য কিন্তু উক্তি II সত্য

Question Number : 40 Question Id : 86435140 Question Type : MCQ Option Shuffling : Yes Is Question Mandatory : No

Correct Marks : 4 Wrong Marks : 1

The type of pollution that gets increased during the day time and in the presence of O_3 is :

Options :

864351127. Reducing smog

864351128. Oxidising smog

864351129. Acid rain

864351130. Global warming

Question Number : 40 Question Id : 86435140 Question Type : MCQ Option Shuffling : Yes Is Question Mandatory : No

Correct Marks : 4 Wrong Marks : 1

প্রদূষণৰ প্ৰকাৰ যিটো দিনৰ সময়ছোৱাত আৰু O_3 ৰ উপস্থিতিত বাঢ়ে :

Options :

864351127. বিজাৰক ধূৱলী

864351128. জাৰক ধূৱলী

864351129. এছিড বৰষুণ

864351130. গোলকীয় তাপবৃদ্ধি

Question Number : 41 Question Id : 86435141 Question Type : MCQ Option Shuffling : Yes Is Question Mandatory : No

Correct Marks : 4 Wrong Marks : 1

In chromatography technique, the purification of compound is independent of :

Options :

864351131. Solubility of the compound

864351132. Mobility or flow of solvent system

864351133. Length of the column or TLC plate

864351134. Physical state of the pure compound

Question Number : 41 Question Id : 86435141 Question Type : MCQ Option Shuffling : Yes Is Question Mandatory : No

Correct Marks : 4 Wrong Marks : 1

বৰ্ণলেখন পদ্ধতিত, যৌগৰ শোধন স্বতন্ত্ৰ হয় :

Options :

864351131. যৌগৰ দ্ৰৱণীয়তা

864351132. দ্ৰাৱকৰ গতিশীলতা বা বৈ যোৱা

864351133. স্তম্ভৰ দৈৰ্ঘ্য বা TLC প্লেট

864351134. **বিশুদ্ধ যৌগৰ ভৌতিক অৱস্থাৰ ওপৰত**

Question Number : 42 Question Id : 86435142 Question Type : MCQ Option Shuffling : Yes Is Question Mandatory : No

Correct Marks : 4 Wrong Marks : 1

Among the following, the aromatic compounds are :

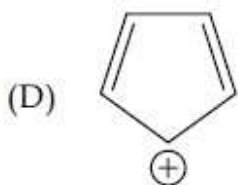
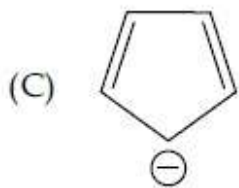
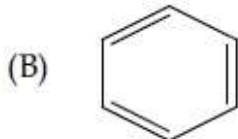
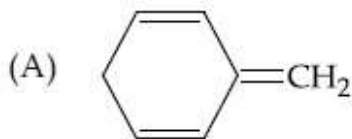

Choose the correct answer from the following options :

Options :

864351135. (A) and (B) only

864351136. (A), (B) and (C) only

864351137. (B), (C) and (D) only

864351138. (B) and (C) only

Question Number : 42 Question Id : 86435142 Question Type : MCQ Option Shuffling : Yes Is Question Mandatory : No

Correct Marks : 4 Wrong Marks : 1

তলত দিয়াবোৰৰ ভিতৰত, এৰ'মেটিক যৌগবোৰ হ'ল :

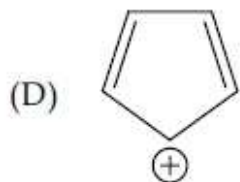
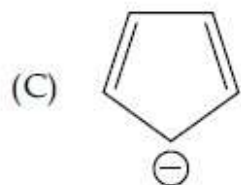
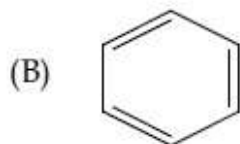

নিম্নলিখিত বিকল্পৰপৰা শুদ্ধ উত্তৰ বাছি উলিওৱা :

Options :

864351135. (A) আৰু (B)

864351136. (A), (B) আৰু (C)

864351137. (B), (C) আৰু (D)

864351138. (B) আৰু (C) মাত্ৰ

Question Number : 43 Question Id : 86435143 Question Type : MCQ Option Shuffling : Yes Is Question Mandatory : No

Correct Marks : 4 Wrong Marks : 1

Which of the following is Lindlar catalyst ?

Options :

864351139. Partially deactivated palladised charcoal

864351140. Sodium and Liquid NH_3

864351141. Cold dilute solution of KMnO_4

864351142. Zinc chloride and HCl

Question Number : 43 Question Id : 86435143 Question Type : MCQ Option Shuffling : Yes Is Question Mandatory : No

Correct Marks : 4 Wrong Marks : 1

তলৰ কোনটো লিগুলাৰ অনুঘটক ?

Options :

864351139. আংশিকভাৱে নিষ্ক্রিয় পেলেডাইজড চাৰ্কোল

864351140. ছডিয়াম আৰু তৰল NH_3

864351141. KMnO_4 ৰ শীতল পন্থীয়া দ্ৰৱ

864351142. জিংক ক্লৰাইড আৰু HCl

Question Number : 44 Question Id : 86435144 Question Type : MCQ Option Shuffling : Yes Is Question Mandatory : No

Correct Marks : 4 Wrong Marks : 1

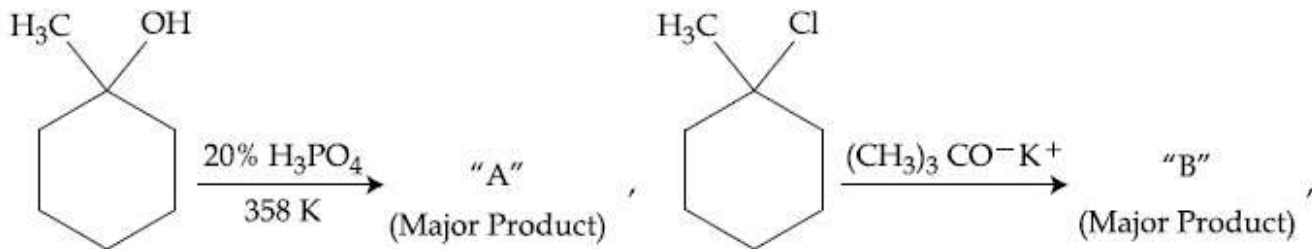

The products "A" and "B" formed in above reactions are :

Options :

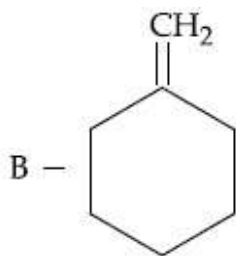
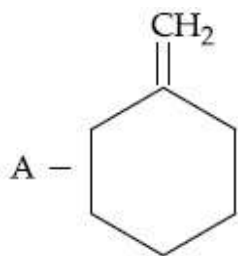

864351143.

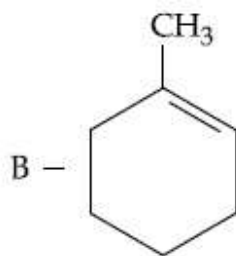
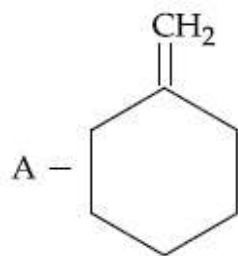

864351144.

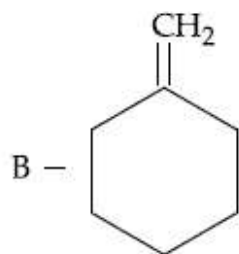
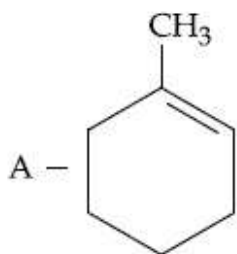

864351145.

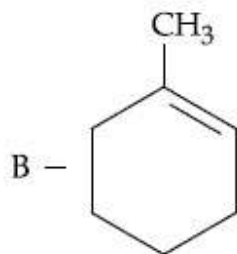
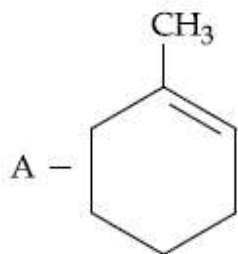

864351146.

Question Number : 44 Question Id : 86435144 Question Type : MCQ Option Shuffling : Yes Is Question Mandatory : No

Correct Marks : 4 Wrong Marks : 1

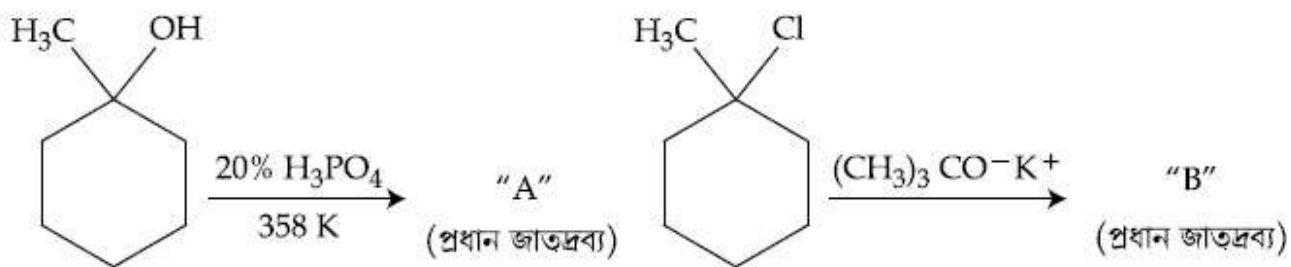

ওপৰৰ বিক্ৰিয়াত উৎপন্ন হোৱা জাতদ্রব্য "A" আৰু "B" হ'ল :

Options :

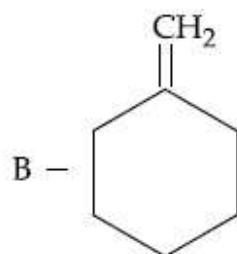
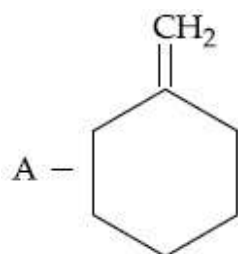

864351143.

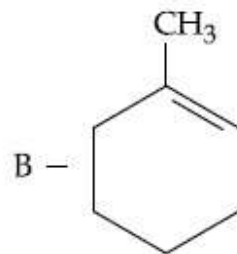
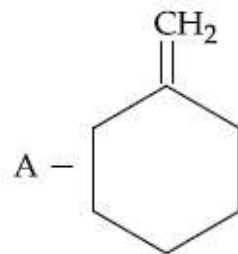

864351144.

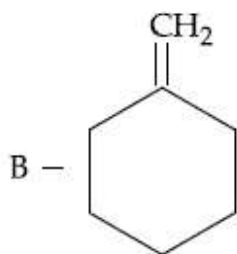
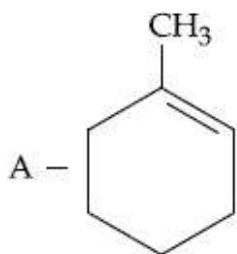

864351145.

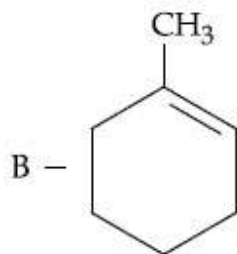
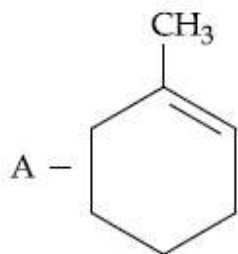

864351146.

Question Number : 45 Question Id : 86435145 Question Type : MCQ Option Shuffling : Yes Is Question Mandatory : No

Correct Marks : 4 Wrong Marks : 1

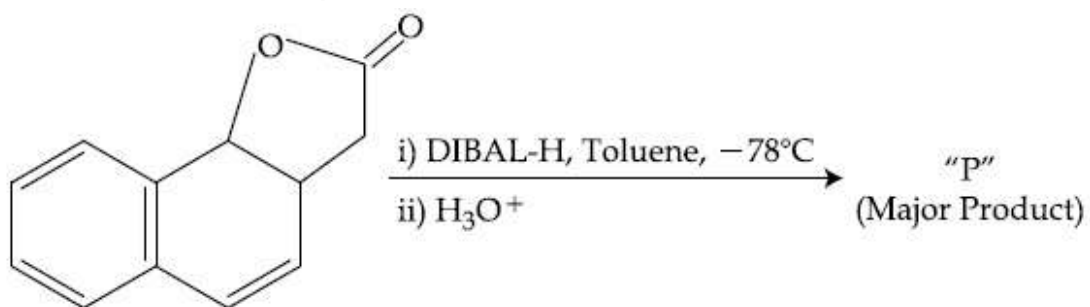

The product "P" in the above reaction is :

Options :

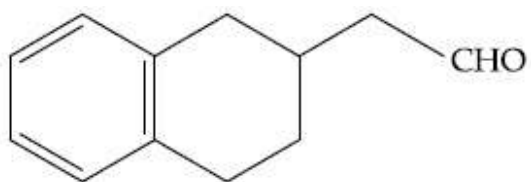

864351147.

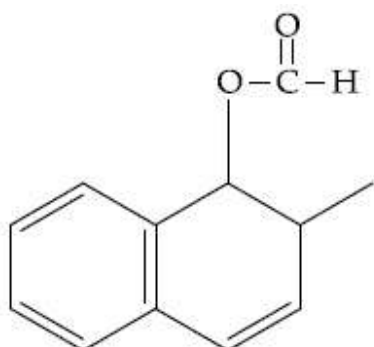

864351148.

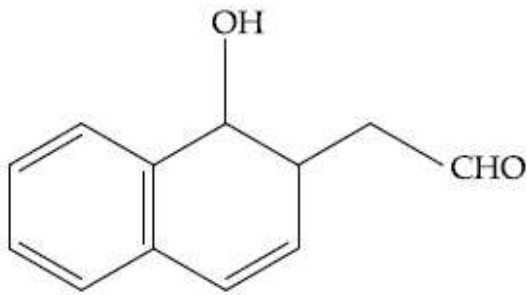

864351149.

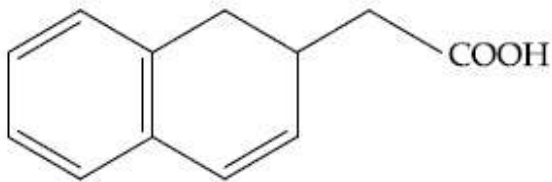

864351150.

Question Number : 45 Question Id : 86435145 Question Type : MCQ Option Shuffling : Yes Is Question Mandatory : No

Correct Marks : 4 Wrong Marks : 1

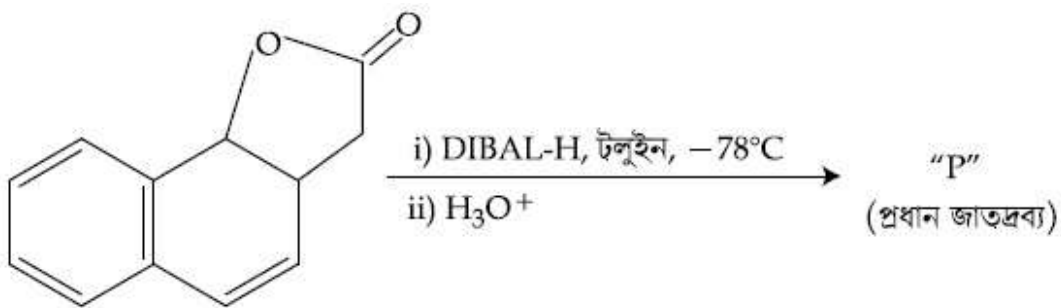

ওপৰৰ বিক্ৰিয়াত জাতদ্রব্য "P" হ'ল :

Options :

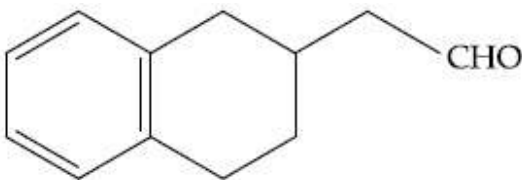

864351147.

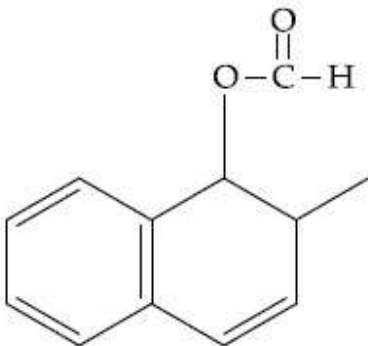

864351148.

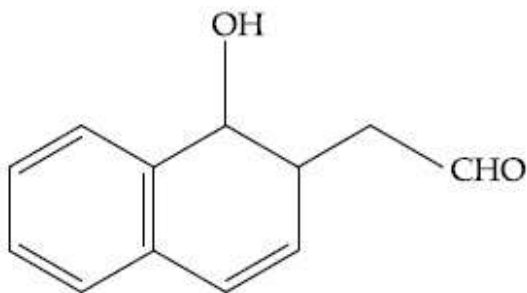

864351149.

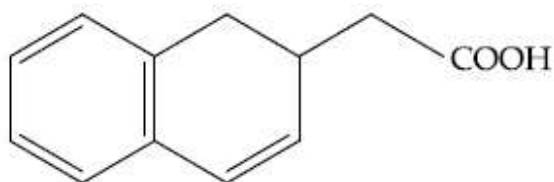

864351150.

Question Number : 46 Question Id : 86435146 Question Type : MCQ Option Shuffling : Yes Is Question Mandatory : No

Correct Marks : 4 Wrong Marks : 1

Assertion A : Enol form of acetone [CH_3COCH_3] exists in $< 0.1\%$ quantity. However, the enol form of acetyl acetone [$\text{CH}_3\text{COCH}_2\text{OCCH}_3$] exists in approximately 15% quantity.

Reason R : Enol form of acetyl acetone is stabilized by intramolecular hydrogen bonding, which is not possible in enol form of acetone.

Choose the correct statement :

Options :

864351151. Both A and R are true and R is the correct explanation of A

864351152. Both A and R are true but R is not the correct explanation of A

864351153. A is true but R is false

864351154. A is false but R is true

Question Number : 46 Question Id : 86435146 Question Type : MCQ Option Shuffling : Yes Is Question Mandatory : No

Correct Marks : 4 Wrong Marks : 1

নিশ্চয়োক্তি A : এছিট'নৰ [CH₃COCH₃] ইন'ল কপ < 0.1% মাত্ৰাত থাকে। য'ত এছিটাইল এছিটন [CH₃COCH₂OCCH₃] ৰ ইন'ল কপ মোটামোটিভাৱে 15% মাত্ৰাত থাকে।

কাৰণ R : এছিটাইল এছিটনৰ ইন'ল কপটো অন্তঃআনৱিক হাইড্ৰজেন বান্ধনীৰ দ্বাৰা সুস্থিৰ কৰা হয়, যিটো এছিট'নৰ ইন'ল কপৰ কাৰণে সম্ভৱ নহয়।

শুদ্ধ উক্তিটো বাছি উলিওৱা :

Options :

864351151. A আৰু R দুয়োটা সত্য আৰু R হ'ল A ৰ শুদ্ধ ব্যাখ্যা।

864351152. A আৰু R দুয়োটা সত্য, কিন্তু R, A ৰ শুদ্ধ ব্যাখ্যা নহয়।

864351153. A সত্য কিন্তু R অসত্য।

864351154. A অসত্য কিন্তু R সত্য।

Question Number : 47 Question Id : 86435147 Question Type : MCQ Option Shuffling : Yes Is Question Mandatory : No

Correct Marks : 4 Wrong Marks : 1

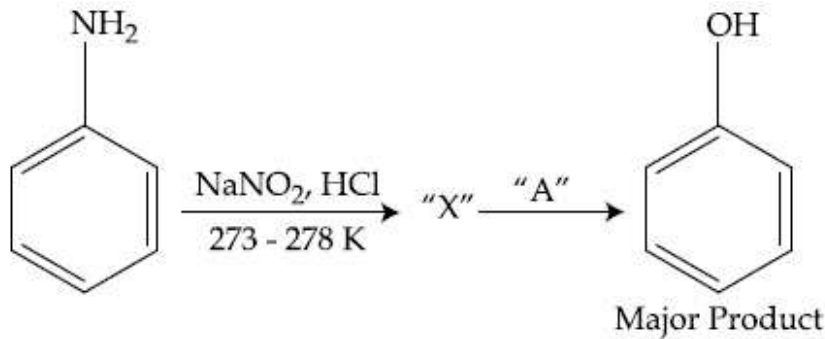

In the above chemical reaction, intermediate "X" and reagent/condition "A" are :

Options :

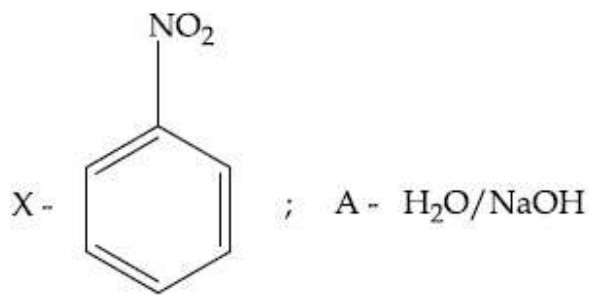

864351155.

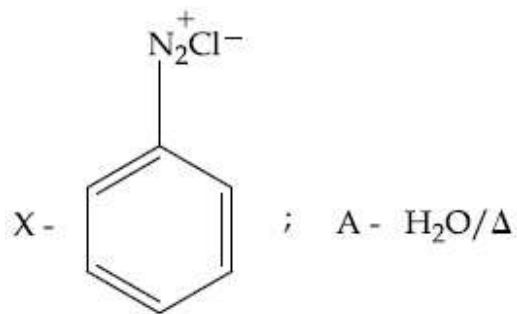

864351156.

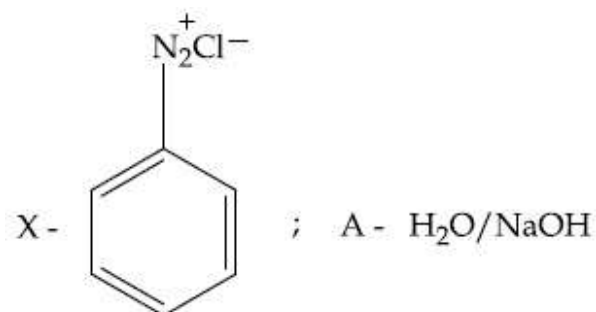

864351157.

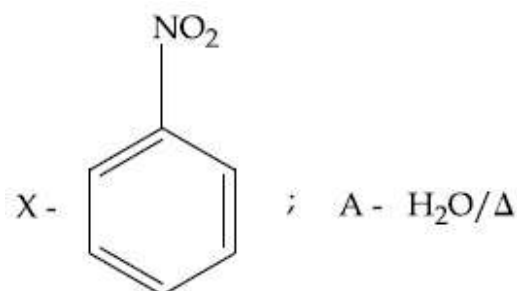

864351158.

Question Number : 47 Question Id : 86435147 Question Type : MCQ Option Shuffling : Yes Is Question Mandatory : No

Correct Marks : 4 Wrong Marks : 1

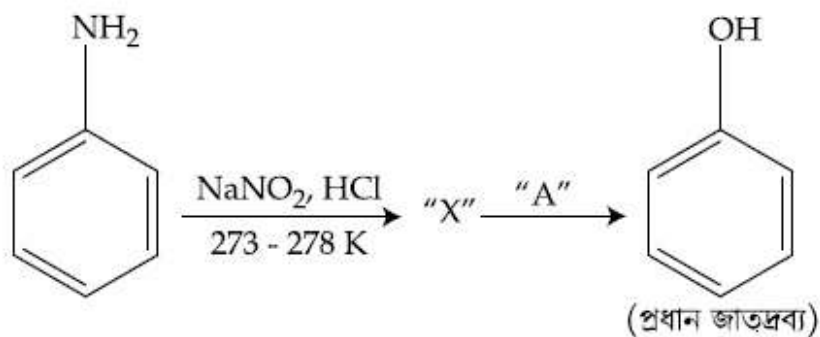

ওপৰৰ ৰাসায়নিক বিক্ৰিয়াৰ, মধ্যস্থকাৰী "X" আৰু বিকাৰক/স্বৰ্ত "A" ৰ :

Options :

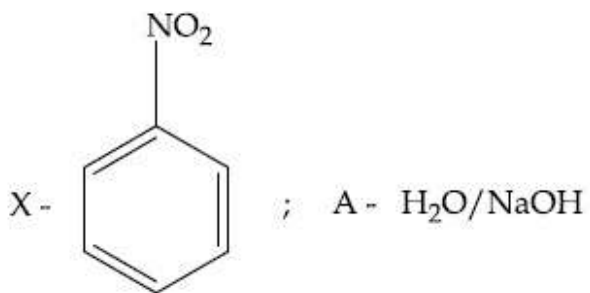

864351155.

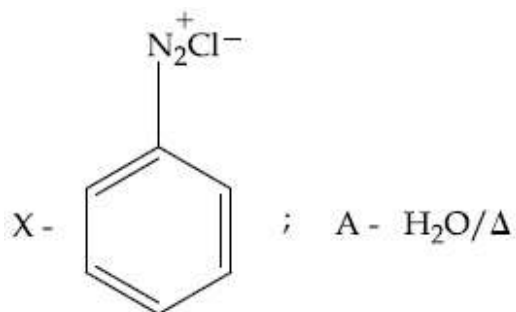

864351156.

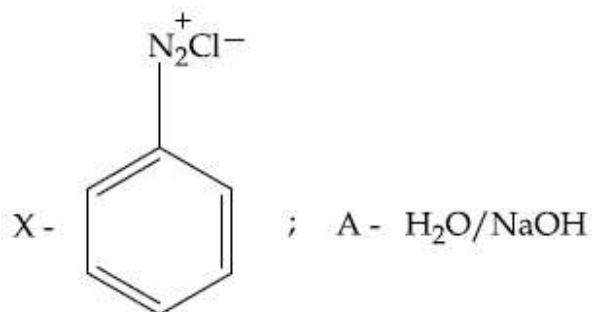

864351157.

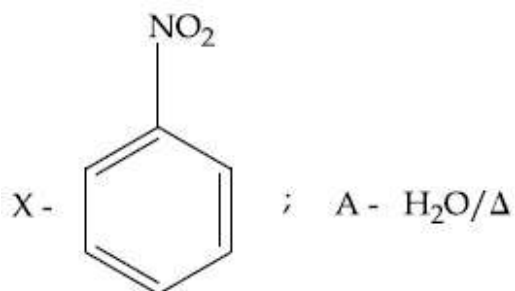

864351158.

Question Number : 48 Question Id : 86435148 Question Type : MCQ Option Shuffling : Yes Is Question Mandatory : No

Correct Marks : 4 Wrong Marks : 1

Which of the following reaction DOES NOT involve Hoffmann bromamide degradation ?

Options :

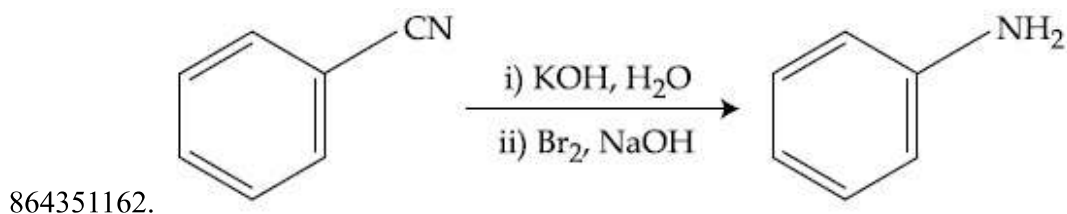
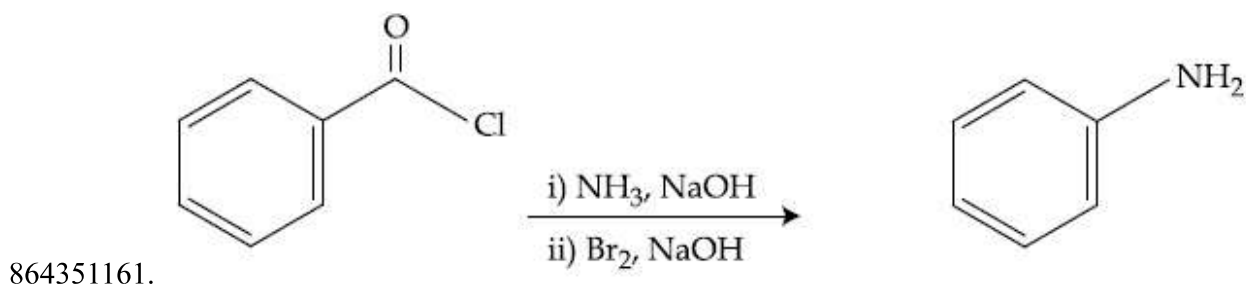
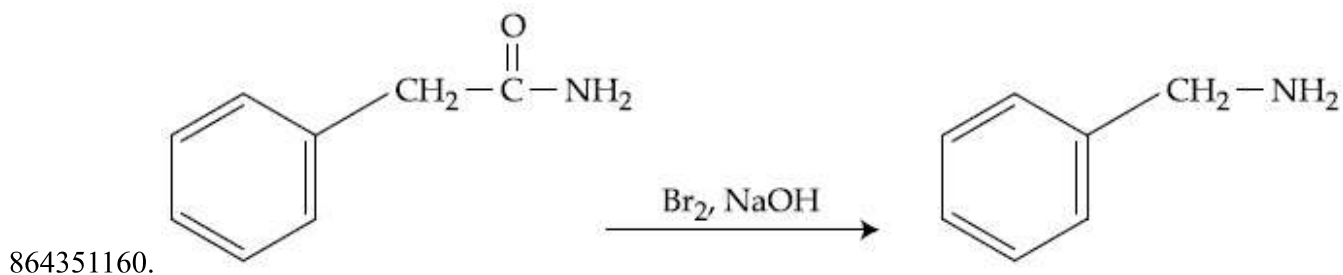
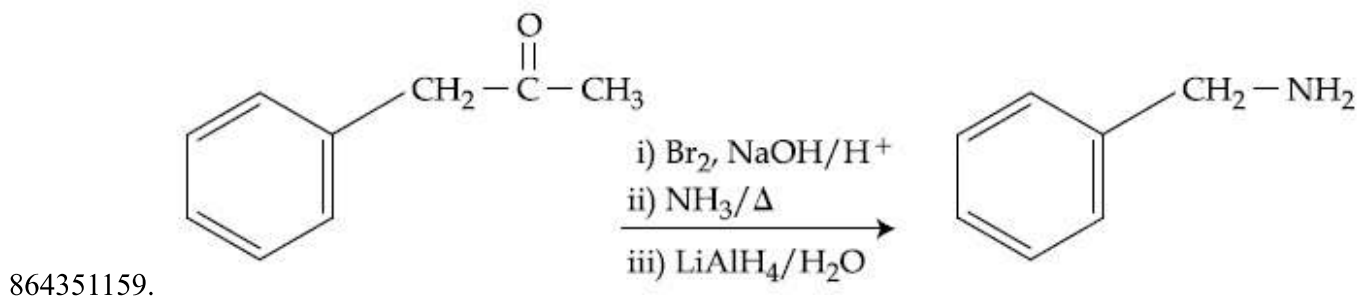

Question Number : 48 Question Id : 86435148 Question Type : MCQ Option Shuffling : Yes Is Question Mandatory : No

Correct Marks : 4 Wrong Marks : 1

তলৰ কোনটো বিক্ৰিয়াই হ'ফমেন ব্ৰুমায়াইড অৱনমনত লিপ্ত নহয় ?

Options :

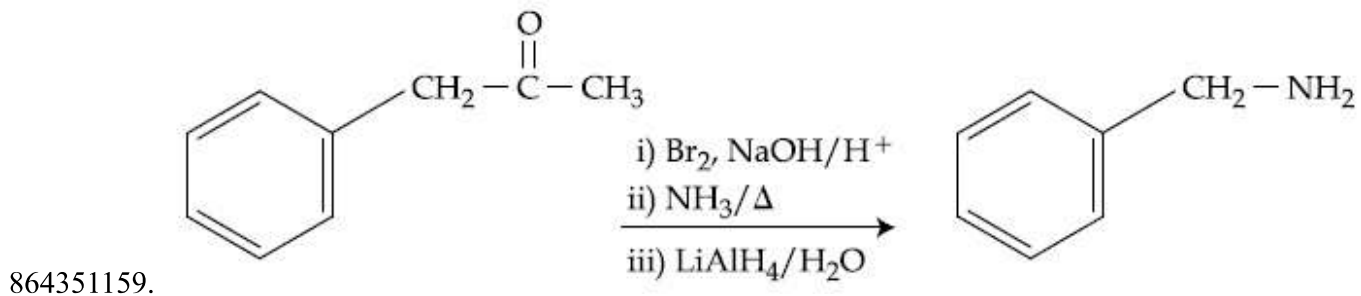

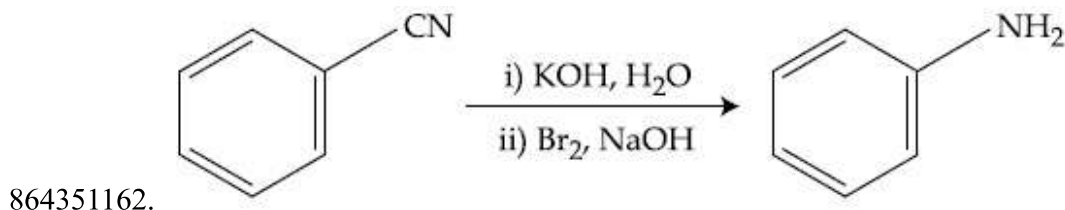
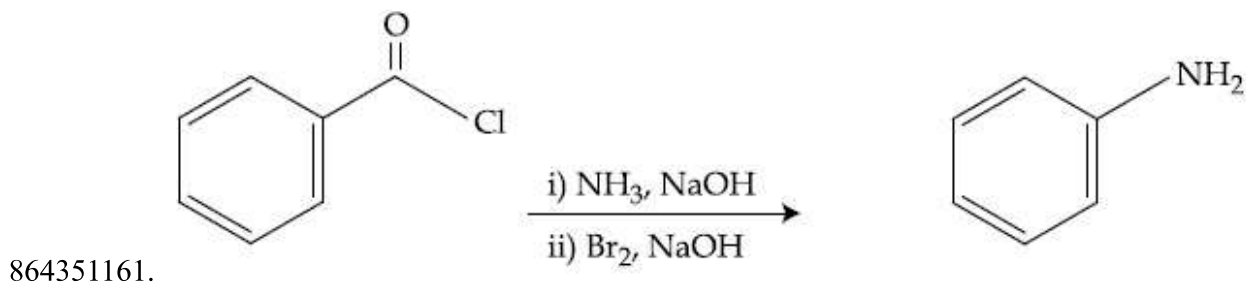
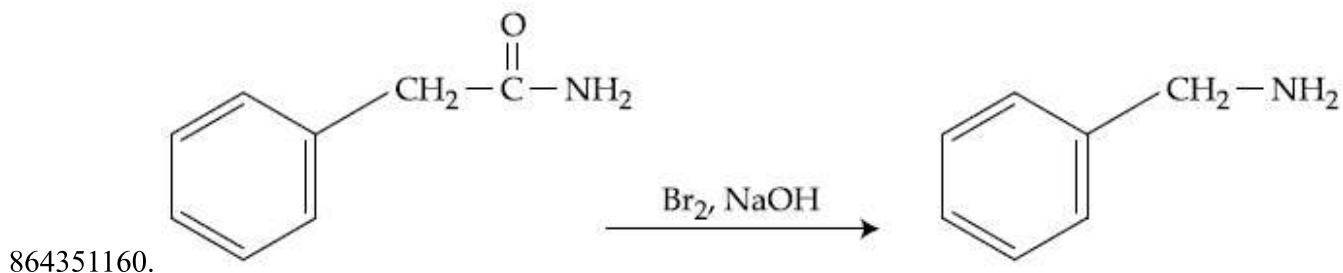

Question Number : 49 Question Id : 86435149 Question Type : MCQ Option Shuffling : Yes Is Question Mandatory : No

Correct Marks : 4 Wrong Marks : 1

The functions of antihistamine are :

Options :

864351163. Antiallergic and Analgesic

864351164. Analgesic and antacid

864351165. Antacid and antiallergic

864351166. Antiallergic and antidepressant

Question Number : 49 Question Id : 86435149 Question Type : MCQ Option Shuffling : Yes Is Question Mandatory : No

Correct Marks : 4 Wrong Marks : 1

এন্টিহিস্টামাইনৰ কৰ্মবোৰ :

Options :

864351163. এলাৰ্জীৰোধী আৰু বেদনাহাৰী

864351164. বেদনাহাৰী আৰু এণ্টাছিড

864351165. এণ্টাছিড আৰু এলাৰ্জীৰোধী

864351166. এলাৰ্জীৰোধী আৰু বিষণ্ণতাৰোধী

Question Number : 50 Question Id : 86435150 Question Type : MCQ Option Shuffling : Yes Is Question Mandatory : No

Correct Marks : 4 Wrong Marks : 1

Which among the following pairs of Vitamins is stored in our body relatively for longer duration ?

Options :

864351167. Thiamine and Ascorbic acid

864351168. Vitamin A and Vitamin D

864351169. Thiamine and Vitamin A

864351170. Ascorbic acid and Vitamin D

Question Number : 50 Question Id : 86435150 Question Type : MCQ Option Shuffling : Yes Is Question Mandatory : No

Correct Marks : 4 Wrong Marks : 1

নিম্নলিখিতৰ পৰা কোনটো ভিটামিনৰ যোৰ, যিটো আমাৰ দেহত তুলনামূলকভাৱে বেছি সময়লৈ জমা থাকে ?

Options :

864351167. থায়ামাইন আৰু এছক'ৰবিক এছিড

864351168. ভিটামিন A আৰু ভিটামিন D

864351169. থায়ামাইন আৰু ভিটামিন A

864351170. এছক'ৰবিক এছিড আৰু ভিটামিন D

Chemistry Section B

Section Id :	8643514
Section Number :	4
Section type :	Online
Mandatory or Optional :	Mandatory
Number of Questions :	10
Number of Questions to be attempted :	5
Section Marks :	20
Mark As Answered Required? :	Yes
Sub-Section Number :	1
Sub-Section Id :	8643514
Question Shuffling Allowed :	Yes

Question Number : 51 Question Id : 86435151 Question Type : SA

Correct Marks : 4 Wrong Marks : 0

A 6.50 molal solution of KOH (aq.) has a density of 1.89 g cm^{-3} . The molarity of the solution is _____ mol dm^{-3} . (Round off to the Nearest Integer).

[Atomic masses : K : 39.0 u; O : 16.0 u; H : 1.0 u]

Response Type : Numeric

Evaluation Required For SA : Yes

Show Word Count : Yes

Answers Type : Equal

Text Areas : PlainText

Possible Answers :

100

Question Number : 51 Question Id : 86435151 Question Type : SA

Correct Marks : 4 Wrong Marks : 0

KOH (aq.) ৰ 6.50 ম'লাল দ্ৰৱ এটাৰ ঘনত্ব 1.89 g cm^{-3} । দ্ৰৱটোৰ ম'লাৰিটি _____ mol dm^{-3} ।

(নিকটতম অখণ্ড সংখ্যাত)।

[পাৰমাণৱিক ভৰ : K : 39.0 u; O : 16.0 u; H : 1.0 u]

Response Type : Numeric

Evaluation Required For SA : Yes

Show Word Count : Yes

Answers Type : Equal

Text Areas : PlainText

Possible Answers :

100

Question Number : 52 Question Id : 86435152 Question Type : SA

Correct Marks : 4 Wrong Marks : 0

A certain element crystallises in a bcc lattice of unit cell edge length 27\AA . If the same element under the same conditions crystallises in the fcc lattice, the edge length of the unit cell in \AA will be _____. (Round off to the Nearest Integer).

[Assume each lattice point has a single atom]

[Assume $\sqrt{3} = 1.73$, $\sqrt{2} = 1.41$]

Response Type : Numeric

Evaluation Required For SA : Yes

Show Word Count : Yes

Answers Type : Equal

Text Areas : PlainText

Possible Answers :

100

Question Number : 52 Question Id : 86435152 Question Type : SA

Correct Marks : 4 Wrong Marks : 0

এটা মৌলৰ bcc লোটিছত স্ফটিকীকৰণ হয় যাৰ একক কোষৰ দাঁতি দৈৰ্ঘ্য 27\AA । যদি সেই একেটা মৌলৰ একে স্বৰ্তত fcc লোটিছত স্ফটিকীকৰণ হয়, তেন্তে একক কোষৰ \AA ত দাঁতি দৈৰ্ঘ্য হ'ব _____। (নিকটতম অখণ্ড সংখ্যাত)।

[ধৰিলোৱা প্ৰত্যেক লোটিছ বিন্দুত এটা একক পৰমাণু আছে।]

[ধৰিলোৱা $\sqrt{3} = 1.73$, $\sqrt{2} = 1.41$]

Response Type : Numeric

Evaluation Required For SA : Yes

Show Word Count : Yes

Answers Type : Equal

Text Areas : PlainText

Possible Answers :

100

Question Number : 53 Question Id : 86435153 Question Type : SA

Correct Marks : 4 Wrong Marks : 0

When light of wavelength 248 nm falls on a metal of threshold energy 3.0 eV , the de-Broglie wavelength of emitted electrons is _____ \AA . (Round off to the Nearest Integer).

[Use : $\sqrt{3} = 1.73$, $h = 6.63 \times 10^{-34}\text{ Js}$

$m_e = 9.1 \times 10^{-31}\text{ kg}$; $c = 3.0 \times 10^8\text{ ms}^{-1}$; $1\text{ eV} = 1.6 \times 10^{-19}\text{ J}$]

Response Type : Numeric

Evaluation Required For SA : Yes

Show Word Count : Yes

Answers Type : Equal

Text Areas : PlainText

Possible Answers :

100

Question Number : 53 Question Id : 86435153 Question Type : SA

Correct Marks : 4 Wrong Marks : 0

যেতিয়া 248 nm তৰংগদৈৰ্ঘ্যৰ পোহৰ এখন ধাতুৰ ওপৰত পৰে যাৰ প্ৰভাৱসীমা শক্তি 3.0 eV, নিৰ্গত হোৱা ইলেক্ট্ৰনৰ ডি-ব্ৰাগলি তৰংগদৈৰ্ঘ্য হ'ল _____ Å। (নিকটতম অখণ্ড সংখ্যাত)।

[ব্যৱহাৰ কৰা : $\sqrt{3} = 1.73$, $h = 6.63 \times 10^{-34}$ Js

$m_e = 9.1 \times 10^{-31}$ kg ; $c = 3.0 \times 10^8$ ms⁻¹ ; 1 eV = 1.6×10^{-19} J]

Response Type : Numeric

Evaluation Required For SA : Yes

Show Word Count : Yes

Answers Type : Equal

Text Areas : PlainText

Possible Answers :

100

Question Number : 54 Question Id : 86435154 Question Type : SA

Correct Marks : 4 Wrong Marks : 0

For the reaction $A(g) \rightleftharpoons B(g)$ at 495 K, $\Delta_r G^\circ = -9.478$ kJ mol⁻¹.

If we start the reaction in a closed container at 495 K with 22 millimoles of A, the amount of B in the equilibrium mixture is _____ millimoles. (Round off to the Nearest Integer).

[R = 8.314 J mol⁻¹ K⁻¹ ; ln 10 = 2.303]

Response Type : Numeric

Evaluation Required For SA : Yes

Show Word Count : Yes

Answers Type : Equal

Text Areas : PlainText

Possible Answers :

100

Question Number : 54 Question Id : 86435154 Question Type : SA

Correct Marks : 4 Wrong Marks : 0

বিক্রিয়াটোৰ বাবে $A(g) \rightleftharpoons B(g)$ 495 K ত, $\Delta_r G^\circ = -9.478 \text{ kJ mol}^{-1}$.

যদি আমি বিক্ৰিয়াটো 495 K ত 22 মিলিম'ল A ৰ সৈতে এটা বন্ধ পাত্ৰত আবদ্ধ কৰোঁ, সাম্য মিশ্ৰটোত B ৰ পৰিমাণ _____ millimoles। (নিকটতম অখণ্ড সংখ্যাত)।

[$R = 8.314 \text{ J mol}^{-1} \text{ K}^{-1}$; $\ln 10 = 2.303$]

Response Type : Numeric

Evaluation Required For SA : Yes

Show Word Count : Yes

Answers Type : Equal

Text Areas : PlainText

Possible Answers :

100

Question Number : 55 **Question Id :** 86435155 **Question Type :** SA

Correct Marks : 4 **Wrong Marks :** 0

AB_2 is 10% dissociated in water to A^{2+} and B^- . The boiling point of a 10.0 molal aqueous solution of AB_2 is _____ $^\circ\text{C}$. (Round off to the Nearest Integer).

[Given : Molal elevation constant of water $K_b = 0.5 \text{ K kg mol}^{-1}$ boiling point of pure water = 100°C]

Response Type : Numeric

Evaluation Required For SA : Yes

Show Word Count : Yes

Answers Type : Equal

Text Areas : PlainText

Possible Answers :

100

Question Number : 55 **Question Id :** 86435155 **Question Type :** SA

Correct Marks : 4 **Wrong Marks :** 0

পানীত AB_2 ৰ 10% বিয়োজন হৈ দিয়ে A^{2+} আৰু B^- । AB_2 ৰ 10.0 ম'লাল জলীয় দ্ৰব এটাৰ উতলাংক _____ $^\circ\text{C}$ । (নিকটতম অখণ্ড সংখ্যাত)।

[দিয়া আছে : ম'লাল উতলাংকৰ উন্নয়ন, পানীৰ $K_b = 0.5 \text{ K kg mol}^{-1}$ । বিশুদ্ধ পানীৰ উতলাংক = 100°C]

Response Type : Numeric

Evaluation Required For SA : Yes

Show Word Count : Yes

Answers Type : Equal

Text Areas : PlainText

Possible Answers :

100

Question Number : 56 Question Id : 86435156 Question Type : SA

Correct Marks : 4 Wrong Marks : 0

Two salts A_2X and MX have the same value of solubility product of 4.0×10^{-12} . The ratio of

their molar solubilities i.e. $\frac{S(A_2X)}{S(MX)} = \text{_____}$. (Round off to the Nearest Integer).

Response Type : Numeric

Evaluation Required For SA : Yes

Show Word Count : Yes

Answers Type : Equal

Text Areas : PlainText

Possible Answers :

100

Question Number : 56 Question Id : 86435156 Question Type : SA

Correct Marks : 4 Wrong Marks : 0

দুটা লৱণ A_2X আৰু MX ৰ একে দ্ৰাৱ্যতা গুণফল, 4.0×10^{-12} । সিহঁতৰ ম'লাৰ দ্ৰাৱ্যতাৰ অনুপাত, য'ত $\frac{S(A_2X)}{S(MX)} =$

_____। (নিকটতম অখণ্ড সংখ্যাত)

Response Type : Numeric

Evaluation Required For SA : Yes

Show Word Count : Yes

Answers Type : Equal

Text Areas : PlainText

Possible Answers :

100

Question Number : 57 Question Id : 86435157 Question Type : SA

Correct Marks : 4 Wrong Marks : 0

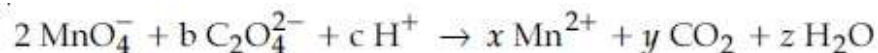

If the above equation is balanced with integer coefficients, the value of c is _____.
(Round off to the Nearest Integer).

Response Type : Numeric

Evaluation Required For SA : Yes

Show Word Count : Yes

Answers Type : Equal

Text Areas : PlainText

Possible Answers :

100

Question Number : 57 Question Id : 86435157 Question Type : SA

Correct Marks : 4 Wrong Marks : 0

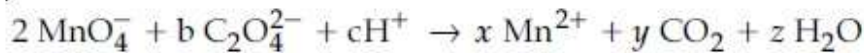

যদি ওপৰৰ সমীকৰণটো সমতুল কৰা হয় অখণ্ড গুণাংকৰে, c ৰ মান হ'ল _____ । (নিকটতম অখণ্ড সংখ্যাত)

Response Type : Numeric

Evaluation Required For SA : Yes

Show Word Count : Yes

Answers Type : Equal

Text Areas : PlainText

Possible Answers :

100

Question Number : 58 Question Id : 86435158 Question Type : SA

Correct Marks : 4 Wrong Marks : 0

The decomposition of formic acid on gold surface follows first order kinetics. If the rate constant at 300 K is $1.0 \times 10^{-3} \text{ s}^{-1}$ and the activation energy $E_a = 11.488 \text{ kJ mol}^{-1}$, the rate constant at 200 K is _____ $\times 10^{-5} \text{ s}^{-1}$. (Round off to the Nearest Integer).

(Given : $R = 8.314 \text{ J mol}^{-1} \text{ K}^{-1}$)

Response Type : Numeric

Evaluation Required For SA : Yes

Show Word Count : Yes

Answers Type : Equal

Text Areas : PlainText

Possible Answers :

100

Question Number : 58 Question Id : 86435158 Question Type : SA

Correct Marks : 4 Wrong Marks : 0

ফৰমিক এছিডৰ সোণৰ পৃষ্ঠত বিয়োজনে প্ৰথম ক্ৰমৰ গতিবিজ্ঞান মানি চলে। যদি 300 K ত, গতিপ্ৰৱক $1.0 \times 10^{-3} \text{ s}^{-1}$ আৰু সক্ৰিয় শক্তি $E_a = 11.488 \text{ kJ mol}^{-1}$, তেন্তে 200 K ত গতি প্ৰৱক হ'ল _____ $\times 10^{-5} \text{ s}^{-1}$ । (নিকটতম অখণ্ড সংখ্যাত)

(দিয়া আছে : $R = 8.314 \text{ J mol}^{-1} \text{ K}^{-1}$)

Response Type : Numeric

Evaluation Required For SA : Yes

Show Word Count : Yes

Answers Type : Equal

Text Areas : PlainText

Possible Answers :

100

Question Number : 59 Question Id : 86435159 Question Type : SA

Correct Marks : 4 Wrong Marks : 0

The equivalents of ethylene diamine required to replace the neutral ligands from the coordination sphere of the trans-complex of $\text{CoCl}_3 \cdot 4\text{NH}_3$ is _____. (Round off to the Nearest Integer).

Response Type : Numeric

Evaluation Required For SA : Yes

Show Word Count : Yes

Answers Type : Equal

Text Areas : PlainText

Possible Answers :

100

Question Number : 59 Question Id : 86435159 Question Type : SA

Correct Marks : 4 Wrong Marks : 0

দৰকাৰ হোৱা সমতুল্য ইথিলিন ডাইএমাইনৰ পৰিমাণ যিয়ে ট্ৰেন্স $\text{CoCl}_3 \cdot 4\text{NH}_3$ জটিলৰ সমগ্ৰী চক্ৰৰ পৰা প্ৰশম লিগাণ্ডৰ ঠাই পূৰণ কৰিব পাৰে, _____। (নিকটতম অখণ্ড সংখ্যাত)

Response Type : Numeric

Evaluation Required For SA : Yes

Show Word Count : Yes

Answers Type : Equal

Text Areas : PlainText

Possible Answers :

100

Question Number : 60 Question Id : 86435160 Question Type : SA

Correct Marks : 4 Wrong Marks : 0

Complete combustion of 750 g of an organic compound provides 420 g of CO_2 and 210 g of H_2O . The percentage composition of carbon and hydrogen in organic compound is 15.3 and _____ respectively. (Round off to the Nearest Integer).

Response Type : Numeric

Evaluation Required For SA : Yes

Show Word Count : Yes

Answers Type : Equal

Text Areas : PlainText

Possible Answers :

100

Question Number : 60 Question Id : 86435160 Question Type : SA

Correct Marks : 4 Wrong Marks : 0

750 g ৰ এটা জৈৱ যৌগৰ সম্পূৰ্ণ দহনৰ ফলত দিয়ে 420 g CO₂ আৰু 210 g H₂O। জৈৱ যৌগটোত কাৰ্বন আৰু হাইড্ৰজেনৰ শতকৰা সংযুতি হ'ল 15.3 আৰু _____ যথাক্ৰমে। (নিকটতম অখণ্ড সংখ্যাত)

Response Type : Numeric

Evaluation Required For SA : Yes

Show Word Count : Yes

Answers Type : Equal

Text Areas : PlainText

Possible Answers :

100

Mathematics Section A

Section Id :	8643515
Section Number :	5
Section type :	Online
Mandatory or Optional :	Mandatory
Number of Questions :	20
Number of Questions to be attempted :	20
Section Marks :	80
Mark As Answered Required? :	Yes
Sub-Section Number :	1
Sub-Section Id :	8643515
Question Shuffling Allowed :	Yes

Question Number : 61 Question Id : 86435161 Question Type : MCQ Option Shuffling : Yes Is Question Mandatory : No

Correct Marks : 4 Wrong Marks : 1

Let $A = \begin{bmatrix} i & -i \\ -i & i \end{bmatrix}$, $i = \sqrt{-1}$. Then, the system of linear equations $A^8 \begin{bmatrix} x \\ y \end{bmatrix} = \begin{bmatrix} 8 \\ 64 \end{bmatrix}$ has :

Options :

864351181. No solution

864351182. A unique solution

864351183. Infinitely many solutions

864351184. Exactly two solutions

Question Number : 61 Question Id : 86435161 Question Type : MCQ Option Shuffling : Yes Is Question Mandatory : No

Correct Marks : 4 Wrong Marks : 1

ধৰা হ'ল $A = \begin{bmatrix} i & -i \\ -i & i \end{bmatrix}$, $i = \sqrt{-1}$ তেন্তে $A^8 \begin{bmatrix} x \\ y \end{bmatrix} = \begin{bmatrix} 8 \\ 64 \end{bmatrix}$ বৈখিক সমীকৰণ প্ৰণালীটোৰ :

Options :

864351181. সমাধান নাই

864351182. এটা অদ্বিতীয় সমাধান আছে

864351183. অসীম সংখ্যক সমাধান আছে

864351184. কেৱল দুটা সমাধান আছে

Question Number : 62 Question Id : 86435162 Question Type : MCQ Option Shuffling : Yes Is Question Mandatory : No

Correct Marks : 4 Wrong Marks : 1

Let the functions $f: \mathbb{R} \rightarrow \mathbb{R}$ and $g: \mathbb{R} \rightarrow \mathbb{R}$ be defined as :

$$f(x) = \begin{cases} x + 2, & x < 0 \\ x^2, & x \geq 0 \end{cases} \text{ and } g(x) = \begin{cases} x^3, & x < 1 \\ 3x - 2, & x \geq 1 \end{cases}$$

Then, the number of points in \mathbb{R} where $(f \circ g)(x)$ is NOT differentiable is equal to :

Options :

864351185. 0

864351186. 1

864351187. 2

864351188. 3

Question Number : 62 Question Id : 86435162 Question Type : MCQ Option Shuffling : Yes Is Question Mandatory : No

Correct Marks : 4 Wrong Marks : 1

ধরা হ'ল $f: \mathbb{R} \rightarrow \mathbb{R}$ আৰু $g: \mathbb{R} \rightarrow \mathbb{R}$ দুটা ফলন বৰ্ণিত যাতে,

$$f(x) = \begin{cases} x + 2, & x < 0 \\ x^2, & x \geq 0 \end{cases} \text{ আৰু } g(x) = \begin{cases} x^3, & x < 1 \\ 3x - 2, & x \geq 1 \end{cases}$$

তেন্তে \mathbb{R} ত বিন্দুৰ সংখ্যা সমান হ'ব : যত $(f \circ g)(x)$ অৱকলনীয় নহয় :

Options :

864351185. 0

864351186. 1

864351187. 2

864351188. 3

Question Number : 63 Question Id : 86435163 Question Type : MCQ Option Shuffling : Yes Is Question Mandatory : No

Correct Marks : 4 Wrong Marks : 1

Let P be a plane $lx + my + nz = 0$ containing the line, $\frac{1-x}{1} = \frac{y+4}{2} = \frac{z+2}{3}$. If plane P divides the line segment AB joining points A(-3, -6, 1) and B(2, 4, -3) in ratio k : 1 then the value of k is equal to :

Options :

864351189. 2

864351190. 1.5

864351191. 3

864351192. 4

Question Number : 63 Question Id : 86435163 Question Type : MCQ Option Shuffling : Yes Is Question Mandatory : No

Correct Marks : 4 Wrong Marks : 1

ধৰা হ'ল $\frac{1-x}{1} = \frac{y+4}{2} = \frac{z+2}{3}$ ৰেখা থকা $P : lx + my + nz = 0$ এটা সমতল। যদি P সমতলটোৱে

$A(-3, -6, 1)$ আৰু $B(2, 4, -3)$ বিন্দু সংযোগী AB ৰেখাখণ্ডক $k : 1$ অনুপাতত বিভক্ত কৰে, তেন্তে k সমান হ'ব:

Options :

864351189. 2

864351190. 1.5

864351191. 3

864351192. 4

Question Number : 64 Question Id : 86435164 Question Type : MCQ Option Shuffling : Yes Is Question Mandatory : No

Correct Marks : 4 Wrong Marks : 1

If for a > 0 , the feet of perpendiculars from the points $A(a, -2a, 3)$ and $B(0, 4, 5)$ on the plane $lx + my + nz = 0$ are points $C(0, -a, -1)$ and D respectively, then the length of line segment CD is equal to :

Options :

864351193. $\sqrt{31}$

864351194. $\sqrt{66}$

864351195. $\sqrt{41}$

864351196. $\sqrt{55}$

Question Number : 64 Question Id : 86435164 Question Type : MCQ Option Shuffling : Yes Is Question Mandatory : No

Correct Marks : 4 Wrong Marks : 1

যদি $a > 0$ ৰ বাবে, $A(a, -2a, 3)$ আৰু $B(0, 4, 5)$ বিন্দু দুটাৰ $lx + my + nz = 0$ সমতলৰ ওপৰত লম্ববোৰৰ পাদবিন্দু দুটা ক্ৰমে $C(0, -a, -1)$ আৰু D হয়, তেন্তে CD ৰেখাখণ্ডটোৰ দৈৰ্ঘ্য সমান হ'ব :

Options :

864351193. $\sqrt{31}$

864351194. $\sqrt{66}$

864351195. $\sqrt{41}$

864351196. $\sqrt{55}$

Question Number : 65 Question Id : 86435165 Question Type : MCQ Option Shuffling : Yes Is Question Mandatory : No

Correct Marks : 4 Wrong Marks : 1

Consider three observations a, b and c such that $b = a + c$. If the standard deviation of $a + 2, b + 2, c + 2$ is d, then which of the following is true ?

Options :

864351197. $b^2 = 3(a^2 + c^2) - 9d^2$

864351198. $b^2 = 3(a^2 + c^2) + 9d^2$

864351199. $b^2 = a^2 + c^2 + 3d^2$

864351200. $b^2 = 3(a^2 + c^2 + d^2)$

Question Number : 65 Question Id : 86435165 Question Type : MCQ Option Shuffling : Yes Is Question Mandatory : No

Correct Marks : 4 Wrong Marks : 1

a, b আৰু c পৰ্যাবেক্ষণবোৰ বিবেচনা কৰা হ'ল যাতে $b = a + c$ । যদি $a + 2, b + 2, c + 2$ ৰ প্ৰামাণিক বিচ্যুতি d হয়, তেন্তে তলৰ কোনটো সত্য ?

Options :

864351197. $b^2 = 3(a^2 + c^2) - 9d^2$

864351198. $b^2 = 3(a^2 + c^2) + 9d^2$

864351199. $b^2 = a^2 + c^2 + 3d^2$

864351200. $b^2 = 3(a^2 + c^2 + d^2)$

Question Number : 66 Question Id : 86435166 Question Type : MCQ Option Shuffling : Yes Is Question

Mandatory : No

Correct Marks : 4 Wrong Marks : 1

Let the position vectors of two points P and Q be $3\hat{i} - \hat{j} + 2\hat{k}$ and $\hat{i} + 2\hat{j} - 4\hat{k}$, respectively. Let R and S be two points such that the direction ratios of lines PR and QS are $(4, -1, 2)$ and $(-2, 1, -2)$, respectively. Let lines PR and QS intersect at T. If the vector \vec{TA} is perpendicular to both \vec{PR} and \vec{QS} and the length of vector \vec{TA} is $\sqrt{5}$ units, then the modulus of a position vector of A is :

Options :

864351201. $\sqrt{5}$

864351202. $\sqrt{171}$

864351203. $\sqrt{227}$

864351204. $\sqrt{482}$

Question Number : 66 Question Id : 86435166 Question Type : MCQ Option Shuffling : Yes Is Question Mandatory : No

Correct Marks : 4 Wrong Marks : 1

ধৰা হ'ল P আৰু Q বিন্দু দুটাৰ অৱস্থান ভেক্টৰ ক্ৰমে $3\hat{i} - \hat{j} + 2\hat{k}$ আৰু $\hat{i} + 2\hat{j} - 4\hat{k}$ । ধৰা হ'ল R আৰু S দুটা বিন্দু যাতে PR আৰু QS ৰেখা দুডালৰ দিশানুপাত ক্ৰমে $(4, -1, 2)$ আৰু $(-2, 1, -2)$ । ধৰা হ'ল PR আৰু QS ৰেখাদুডালে T ত ছেদ কৰে। যদি \vec{TA} ভেক্টৰটো \vec{PR} আৰু \vec{QS} দুয়ো ভেক্টৰৰ ওপৰত লম্ব আৰু \vec{TA} ভেক্টৰৰ দৈৰ্ঘ্য $\sqrt{5}$ একক হয়, তেন্তে A ৰ অৱস্থান ভেক্টৰৰ পৰম মান হ'ব :

Options :

864351201. $\sqrt{5}$

864351202. $\sqrt{171}$

864351203. $\sqrt{227}$

864351204. $\sqrt{482}$

Question Number : 67 Question Id : 86435167 Question Type : MCQ Option Shuffling : Yes Is Question Mandatory : No

Correct Marks : 4 Wrong Marks : 1

Let a vector $\alpha \hat{i} + \beta \hat{j}$ be obtained by rotating the vector $\sqrt{3} \hat{i} + \hat{j}$ by an angle 45° about the origin in counterclockwise direction in the first quadrant. Then the area of triangle having vertices (α, β) , $(0, \beta)$ and $(0, 0)$ is equal to :

Options :

864351205. $\frac{1}{2}$

864351206. 1

864351207. $2\sqrt{2}$

864351208. $\frac{1}{\sqrt{2}}$

Question Number : 67 Question Id : 86435167 Question Type : MCQ Option Shuffling : Yes Is Question Mandatory : No

Correct Marks : 4 Wrong Marks : 1

ধৰা হ'ল $\sqrt{3} \hat{i} + \hat{j}$ ভেক্টৰটো মূলবিন্দু সাপেক্ষে 45° কোণত ঘড়ীৰ কাঁটাৰ বিপৰীত দিশত ঘূৰাই প্ৰথম চোকত $\alpha \hat{i} + \beta \hat{j}$ ভেক্টৰটো পোৱা গ'ল। তেন্তে (α, β) , $(0, \beta)$ আৰু $(0, 0)$ শীৰ্ষবিন্দু বিশিষ্ট ত্ৰিভুজৰ কালি সমান হ'ব :

Options :

864351205. $\frac{1}{2}$

864351206. 1

864351207. $2\sqrt{2}$

864351208. $\frac{1}{\sqrt{2}}$

Question Number : 68 Question Id : 86435168 Question Type : MCQ Option Shuffling : Yes Is Question Mandatory : No

Correct Marks : 4 Wrong Marks : 1

The number of roots of the equation,

$$(81)^{\sin^2 x} + (81)^{\cos^2 x} = 30$$

in the interval $[0, \pi]$ is equal to :

Options :

864351209. 2

864351210. 3

864351211. 4

864351212. 8

Question Number : 68 Question Id : 86435168 Question Type : MCQ Option Shuffling : Yes Is Question Mandatory : No

Correct Marks : 4 Wrong Marks : 1

$[0, \pi]$ অন্তৰালত $(81)^{\sin^2 x} + (81)^{\cos^2 x} = 30$

সমীকৰণটোৰ মূলৰ সংখ্যা সমান হ'ব :

Options :

864351209. 2

864351210. 3

864351211. 4

864351212. 8

Question Number : 69 Question Id : 86435169 Question Type : MCQ Option Shuffling : Yes Is Question Mandatory : No

Correct Marks : 4 Wrong Marks : 1

A pack of cards has one card missing. Two cards are drawn randomly and are found to be spades. The probability that the missing card is not a spade, is :

Options :

$$864351213. \frac{22}{425}$$

$$864351214. \frac{52}{867}$$

$$864351215. \frac{39}{50}$$

$$864351216. \frac{3}{4}$$

Question Number : 69 Question Id : 86435169 Question Type : MCQ Option Shuffling : Yes Is Question Mandatory : No

Correct Marks : 4 Wrong Marks : 1

এটা তাচপাত পেকেটত এটা তাচপাত হেৰাইছে। যাদৃচ্ছিকভাৱে দুটা তাচপাত টনা হ'ল আৰু ইন্সপন পোৱা গ'ল। হেৰোৱা তাচপাতটো ইন্সপন নোহোৱাৰ সম্ভাৱিতা হ'ব :

Options :

$$864351213. \frac{22}{425}$$

$$864351214. \frac{52}{867}$$

$$864351215. \frac{39}{50}$$

$$864351216. \frac{3}{4}$$

Question Number : 70 Question Id : 86435170 Question Type : MCQ Option Shuffling : Yes Is Question Mandatory : No

Correct Marks : 4 Wrong Marks : 1

The range of $a \in \mathbb{R}$ for which the function

$$f(x) = (4a - 3)(x + \log_e 5) + 2(a - 7) \cot\left(\frac{x}{2}\right) \sin^2\left(\frac{x}{2}\right), \quad x \neq 2n\pi, n \in \mathbb{N}$$

is :

Options :

864351217. $[1, \infty)$

864351218. $(-\infty, -1]$

864351219. $\left[-\frac{4}{3}, 2\right]$

864351220. $(-3, 1)$

Question Number : 70 Question Id : 86435170 Question Type : MCQ Option Shuffling : Yes Is Question Mandatory : No

Correct Marks : 4 Wrong Marks : 1

$f(x) = (4a - 3)(x + \log_e 5) + 2(a - 7) \cot\left(\frac{x}{2}\right) \sin^2\left(\frac{x}{2}\right)$, $x \neq 2n\pi$, $n \in \mathbb{N}$ ফলনটোৰ ক্রান্তিক বিন্দু

আছে যাৰ বাবে $a \in \mathbb{R}$ ৰ পৰিসৰ হ'ব :

Options :

864351217. $[1, \infty)$

864351218. $(-\infty, -1]$

864351219. $\left[-\frac{4}{3}, 2\right]$

864351220. $(-3, 1)$

Question Number : 71 Question Id : 86435171 Question Type : MCQ Option Shuffling : Yes Is Question Mandatory : No

Correct Marks : 4 Wrong Marks : 1

If n is the number of irrational terms in the expansion of $(3^{1/4} + 5^{1/8})^{60}$, then $(n - 1)$ is divisible by :

Options :

864351221. 30

864351222. 8

864351223. 26

864351224. 7

Question Number : 71 Question Id : 86435171 Question Type : MCQ Option Shuffling : Yes Is Question Mandatory : No

Correct Marks : 4 Wrong Marks : 1

$(3\frac{1}{4} + 5\frac{1}{8})^{60}$ বাশিটোত যদি n অপবিমেয় পদৰ সংখ্যা বুজায়, তেন্তে $(n-1)$ বিভাজ্য হ'ব :

Options :

864351221. 30

864351222. 8

864351223. 26

864351224. 7

Question Number : 72 Question Id : 86435172 Question Type : MCQ Option Shuffling : Yes Is Question Mandatory : No

Correct Marks : 4 Wrong Marks : 1

Let $[x]$ denote greatest integer less than or equal to x . If for $n \in \mathbb{N}$,

$$(1 - x + x^3)^n = \sum_{j=0}^{3n} a_j x^j, \text{ then}$$

$$\sum_{j=0}^{\left[\frac{3n}{2}\right]} a_{2j} + 4 \sum_{j=0}^{\left[\frac{3n-1}{2}\right]} a_{2j+1} \text{ is equal to :}$$

Options :

864351225. 2^{n-1}

864351226. n

864351227. 2

864351228. 1

Question Number : 72 Question Id : 86435172 Question Type : MCQ Option Shuffling : Yes Is Question Mandatory : No

Correct Marks : 4 Wrong Marks : 1

ধৰা হ'ল $[x]$ য়ে x ৰ সমান বা x তকৈ সৰু গৰিষ্ঠ সংখ্যা বুজায়। যদি $n \in \mathbb{N}$ ৰ বাবে $(1 - x + x^3)^n = \sum_{j=0}^{3n} a_j x^j$

তেন্তে $\sum_{j=0}^{\lfloor \frac{3n}{2} \rfloor} a_{2j} + 4 \sum_{j=0}^{\lfloor \frac{3n-1}{2} \rfloor} a_{2j+1}$ সমান হ'ব :

Options :

864351225. 2^{n-1}

864351226. n

864351227. 2

864351228. 1

Question Number : 73 Question Id : 86435173 Question Type : MCQ Option Shuffling : Yes Is Question Mandatory : No

Correct Marks : 4 Wrong Marks : 1

Which of the following Boolean expression is a tautology ?

Options :

864351229. $(p \wedge q) \vee (p \vee q)$

864351230. $(p \wedge q) \vee (p \rightarrow q)$

864351231. $(p \wedge q) \wedge (p \rightarrow q)$

864351232. $(p \wedge q) \rightarrow (p \rightarrow q)$

Question Number : 73 Question Id : 86435173 Question Type : MCQ Option Shuffling : Yes Is Question Mandatory : No

Correct Marks : 4 Wrong Marks : 1

তলৰ কোনটো বুলিন বাশি পুনৰুক্তি ?

Options :

864351229. $(p \wedge q) \vee (p \vee q)$

864351230. $(p \wedge q) \vee (p \rightarrow q)$

864351231. $(p \wedge q) \wedge (p \rightarrow q)$

864351232. $(p \wedge q) \rightarrow (p \rightarrow q)$

Question Number : 74 Question Id : 86435174 Question Type : MCQ Option Shuffling : Yes Is Question Mandatory : No

Correct Marks : 4 Wrong Marks : 1

Let $S_k = \sum_{r=1}^k \tan^{-1} \left(\frac{6^r}{2^{2r+1} + 3^{2r+1}} \right)$. Then $\lim_{k \rightarrow \infty} S_k$ is equal to :

Options :

864351233. $\frac{\pi}{2}$

864351234. $\cot^{-1} \left(\frac{3}{2} \right)$

864351235. $\tan^{-1} \left(\frac{3}{2} \right)$

864351236. $\tan^{-1} (3)$

Question Number : 74 Question Id : 86435174 Question Type : MCQ Option Shuffling : Yes Is Question Mandatory : No

Correct Marks : 4 Wrong Marks : 1

ধৰা হ'ল $S_k = \sum_{r=1}^k \tan^{-1} \left(\frac{6^r}{2^{2r+1} + 3^{2r+1}} \right)$ তেন্তে $\lim_{k \rightarrow \infty} S_k$ সমান হ'ব :

Options :

864351233. $\frac{\pi}{2}$

864351234. $\cot^{-1} \left(\frac{3}{2} \right)$

864351235. $\tan^{-1} \left(\frac{3}{2} \right)$

864351236. $\tan^{-1} (3)$

Question Number : 75 Question Id : 86435175 Question Type : MCQ Option Shuffling : Yes Is Question Mandatory : No

Correct Marks : 4 Wrong Marks : 1

The number of elements in the set $\{x \in \mathbb{R} : (|x| - 3) |x + 4| = 6\}$ is equal to :

Options :

864351237. 1

864351238. 2

864351239. 3

864351240. 4

Question Number : 75 Question Id : 86435175 Question Type : MCQ Option Shuffling : Yes Is Question Mandatory : No

Correct Marks : 4 Wrong Marks : 1

$\{x \in \mathbb{R} : (|x| - 3) |x + 4| = 6\}$ সংহতিটোত থকা মৌলিক সংখ্যা সমান হ'ব :

Options :

864351237. 1

864351238. 2

864351239. 3

864351240. 4

Question Number : 76 Question Id : 86435176 Question Type : MCQ Option Shuffling : Yes Is Question Mandatory : No

Correct Marks : 4 Wrong Marks : 1

If for $x \in \left(0, \frac{\pi}{2}\right)$, $\log_{10} \sin x + \log_{10} \cos x = -1$ and $\log_{10}(\sin x + \cos x) = \frac{1}{2}(\log_{10} n - 1)$, $n > 0$,

then the value of n is equal to :

Options :

864351241. 9

864351242. 12

864351243. 16

864351244. 20

Question Number : 76 Question Id : 86435176 Question Type : MCQ Option Shuffling : Yes Is Question Mandatory : No

Correct Marks : 4 Wrong Marks : 1

$x \in \left(0, \frac{\pi}{2}\right)$ ব বাবে, যদি $\log_{10} \sin x + \log_{10} \cos x = -1$ আৰু $\log_{10}(\sin x + \cos x) = \frac{1}{2}(\log_{10} n - 1)$,

$n > 0$, তেন্তে n ৰ মান সমান হ'ব :

Options :

864351241. 9

864351242. 12

864351243. 16

864351244. 20

Question Number : 77 Question Id : 86435177 Question Type : MCQ Option Shuffling : Yes Is Question Mandatory : No

Correct Marks : 4 Wrong Marks : 1

If $y = y(x)$ is the solution of the differential equation, $\frac{dy}{dx} + 2y \tan x = \sin x$, $y\left(\frac{\pi}{3}\right) = 0$, then

the maximum value of the function $y(x)$ over \mathbb{R} is equal to :

Options :

864351245. 8

864351246. $\frac{1}{2}$

864351247. $-\frac{15}{4}$

864351248. $\frac{1}{8}$

Question Number : 77 Question Id : 86435177 Question Type : MCQ Option Shuffling : Yes Is Question Mandatory : No

Correct Marks : 4 Wrong Marks : 1

যদি $\frac{dy}{dx} + 2y \tan x = \sin x$, $y\left(\frac{\pi}{3}\right) = 0$ অৱকলন সমীকৰণটোৰ $y = y(x)$ এটা সমাধান হয় তেন্তে R ৰ ওপৰত

$y(x)$ ফলনটোৰ গৰিষ্ঠ মান সমান হ'ব :

Options :

864351245. 8

864351246. $\frac{1}{2}$

864351247. $-\frac{15}{4}$

864351248. $\frac{1}{8}$

Question Number : 78 Question Id : 86435178 Question Type : MCQ Option Shuffling : Yes Is Question Mandatory : No

Correct Marks : 4 Wrong Marks : 1

The locus of the midpoints of the chord of the circle, $x^2 + y^2 = 25$ which is tangent to the

hyperbola, $\frac{x^2}{9} - \frac{y^2}{16} = 1$ is :

Options :

864351249. $(x^2 + y^2)^2 - 9x^2 + 144y^2 = 0$

864351250. $(x^2 + y^2)^2 - 9x^2 - 16y^2 = 0$

864351251. $(x^2 + y^2)^2 - 9x^2 + 16y^2 = 0$

864351252. $(x^2 + y^2)^2 - 16x^2 + 9y^2 = 0$

Question Number : 78 Question Id : 86435178 Question Type : MCQ Option Shuffling : Yes Is Question Mandatory : No

Correct Marks : 4 Wrong Marks : 1

$x^2 + y^2 = 25$ বৃত্তৰ জ্যাৰ মধ্যবিন্দুৰ সঞ্চাৰ পথটো যি $\frac{x^2}{9} - \frac{y^2}{16} = 1$ পৰাবৃত্তৰ স্পৰ্শক সমান হ'ব :

Options :

864351249. $(x^2 + y^2)^2 - 9x^2 + 144y^2 = 0$

864351250. $(x^2 + y^2)^2 - 9x^2 - 16y^2 = 0$

864351251. $(x^2 + y^2)^2 - 9x^2 + 16y^2 = 0$

864351252. $(x^2 + y^2)^2 - 16x^2 + 9y^2 = 0$

Question Number : 79 Question Id : 86435179 Question Type : MCQ Option Shuffling : Yes Is Question Mandatory : No

Correct Marks : 4 Wrong Marks : 1

If the three normals drawn to the parabola, $y^2 = 2x$ pass through the point $(a, 0)$ $a \neq 0$, then 'a' must be greater than :

Options :

864351253. 1

864351254. -1

864351255. $\frac{1}{2}$

864351256. $-\frac{1}{2}$

Question Number : 79 Question Id : 86435179 Question Type : MCQ Option Shuffling : Yes Is Question Mandatory : No

Correct Marks : 4 Wrong Marks : 1

যদি $y^2 = 2x$ অধিবৃত্তলৈ টনা অভিলম্ব তিনিডাল $(a, 0)$ $a \neq 0$ বিন্দুৰে পাৰ হয় তেন্তে 'a' ডাঙৰ হ'ব :

Options :

864351253. 1

864351254. -1

864351255. $\frac{1}{2}$

864351256. $-\frac{1}{2}$

Question Number : 80 Question Id : 86435180 Question Type : MCQ Option Shuffling : Yes Is Question Mandatory : No

Correct Marks : 4 Wrong Marks : 1

Let a complex number z , $|z| \neq 1$, satisfy $\log_{\frac{1}{\sqrt{2}}} \left(\frac{|z| + 11}{(|z| - 1)^2} \right) \leq 2$. Then, the largest value of

$|z|$ is equal to _____.

Options :

864351257. 5

864351258. 6

864351259. 7

864351260. 8

Question Number : 80 Question Id : 86435180 Question Type : MCQ Option Shuffling : Yes Is Question Mandatory : No

Correct Marks : 4 Wrong Marks : 1

ধৰা হ'ল z এটা জটিল সংখ্যা, $|z| \neq 1$ যি $\log_{\frac{1}{\sqrt{2}}} \left(\frac{|z| + 11}{(|z| - 1)^2} \right) \leq 2$ ক সিদ্ধ কৰে। তেন্তে $|z|$ ৰ গৰিষ্ঠতম মান

সমান হ'ব :

Options :

864351257. 5

864351258. 6

864351259. 7

864351260. 8

Mathematics Section B

Section Id :	8643516
Section Number :	6
Section type :	Online
Mandatory or Optional :	Mandatory
Number of Questions :	10
Number of Questions to be attempted :	5
Section Marks :	20
Mark As Answered Required? :	Yes
Sub-Section Number :	1
Sub-Section Id :	8643516
Question Shuffling Allowed :	Yes

Question Number : 81 Question Id : 86435181 Question Type : SA

Correct Marks : 4 Wrong Marks : 0

Let z and w be two complex numbers such that $w = z\bar{z} - 2z + 2$, $\left| \frac{z+i}{z-3i} \right| = 1$ and $\text{Re}(w)$

has minimum value. Then, the minimum value of $n \in \mathbb{N}$ for which w^n is real, is equal to

_____.

Response Type : Numeric

Evaluation Required For SA : Yes

Show Word Count : Yes

Answers Type : Equal

Text Areas : PlainText

Possible Answers :

100

Question Number : 81 Question Id : 86435181 Question Type : SA

Correct Marks : 4 Wrong Marks : 0

ধৰা হ'ল z আৰু w দুটা জটিল সংখ্যা যাতে $w = z\bar{z} - 2z + 2$, $\left| \frac{z+i}{z-3i} \right| = 1$ আৰু $\text{Re}(w)$ ৰ নিম্নতম মান

আছে। তেন্তে $n \in \mathbb{N}$ ৰ নিম্নতম মান সমান হ'ব যাৰ বাবে w^n বাস্তৱ _____।

Response Type : Numeric

Evaluation Required For SA : Yes

Show Word Count : Yes

Answers Type : Equal

Text Areas : PlainText

Possible Answers :

100

Question Number : 82 **Question Id :** 86435182 **Question Type :** SA

Correct Marks : 4 **Wrong Marks :** 0

Let $f: \mathbb{R} \rightarrow \mathbb{R}$ be a continuous function such that $f(x) + f(x+1) = 2$, for all $x \in \mathbb{R}$. If $I_1 = \int_0^8 f(x) dx$

and $I_2 = \int_{-1}^3 f(x) dx$, then the value of $I_1 + 2I_2$ is equal to _____.

Response Type : Numeric

Evaluation Required For SA : Yes

Show Word Count : Yes

Answers Type : Equal

Text Areas : PlainText

Possible Answers :

100

Question Number : 82 **Question Id :** 86435182 **Question Type :** SA

Correct Marks : 4 **Wrong Marks :** 0

ধৰা হ'ল $f: \mathbb{R} \rightarrow \mathbb{R}$ এটা অবিচ্ছিন্ন ফলন যাতে $f(x) + f(x+1) = 2$ সকলো $x \in \mathbb{R}$ ৰ বাবে। যদি $I_1 = \int_0^8 f(x) dx$

আৰু $I_2 = \int_{-1}^3 f(x) dx$, তেন্তে $I_1 + 2I_2$ ৰ মান সমান হ'ব _____।

Response Type : Numeric

Evaluation Required For SA : Yes

Show Word Count : Yes

Answers Type : Equal

Text Areas : PlainText

Possible Answers :

100

Question Number : 83 Question Id : 86435183 Question Type : SA

Correct Marks : 4 Wrong Marks : 0

If the normal to the curve $y(x) = \int_0^x (2t^2 - 15t + 10) dt$ at a point (a, b) is parallel to the line

$x + 3y = -5$, $a > 1$, then the value of $|a + 6b|$ is equal to _____.

Response Type : Numeric

Evaluation Required For SA : Yes

Show Word Count : Yes

Answers Type : Equal

Text Areas : PlainText

Possible Answers :

100

Question Number : 83 Question Id : 86435183 Question Type : SA

Correct Marks : 4 Wrong Marks : 0

যদি $y(x) = \int_0^x (2t^2 - 15t + 10) dt$ বক্রৰ (a, b) বিন্দুত টনা অভিলম্বডাল $x + 3y = -5$, $a > 1$ রেখাৰ সমান্তৰাল

হয়, তেন্তে $|a + 6b|$ ৰ মান সমান হ'ব _____।

Response Type : Numeric

Evaluation Required For SA : Yes

Show Word Count : Yes

Answers Type : Equal

Text Areas : PlainText

Possible Answers :

100

Question Number : 84 Question Id : 86435184 Question Type : SA

Correct Marks : 4 Wrong Marks : 0

If $\lim_{x \rightarrow 0} \frac{ae^x - b\cos x + ce^{-x}}{x \sin x} = 2$, then $a + b + c$ is equal to _____.

Response Type : Numeric

Evaluation Required For SA : Yes

Show Word Count : Yes

Answers Type : Equal

Text Areas : PlainText

Possible Answers :

100

Question Number : 84 Question Id : 86435184 Question Type : SA

Correct Marks : 4 Wrong Marks : 0

যদি $\lim_{x \rightarrow 0} \frac{ae^x - b\cos x + ce^{-x}}{x \sin x} = 2$, তেন্তে $a + b + c$ সমান হ'ব _____।

Response Type : Numeric

Evaluation Required For SA : Yes

Show Word Count : Yes

Answers Type : Equal

Text Areas : PlainText

Possible Answers :

100

Question Number : 85 **Question Id :** 86435185 **Question Type :** SA

Correct Marks : 4 **Wrong Marks :** 0

Consider an arithmetic series and a geometric series having four initial terms from the set {11, 8, 21, 16, 26, 32, 4}. If the last terms of these series are the maximum possible four digit numbers, then the number of common terms in these two series is equal to _____.

Response Type : Numeric

Evaluation Required For SA : Yes

Show Word Count : Yes

Answers Type : Equal

Text Areas : PlainText

Possible Answers :

100

Question Number : 85 **Question Id :** 86435185 **Question Type :** SA

Correct Marks : 4 **Wrong Marks :** 0

{11, 8, 21, 16, 26, 32, 4} সংহতিটোৰ প্ৰথম চাৰিটা পদলৈ এটা সমান্তৰ শ্ৰেণী আৰু এটা গুণোত্তৰ শ্ৰেণী লোৱা হ'ল। যদি এইবোৰ শ্ৰেণীৰ অন্তিম পদবোৰ সম্ভাৱ্য গৰিষ্ঠ চাৰি অংকীয়া সংখ্যা হয়, তেন্তে এই শ্ৰেণী দুটাৰ সাধাৰণ পদৰ সংখ্যা সমান হ'ব _____।

Response Type : Numeric

Evaluation Required For SA : Yes

Show Word Count : Yes

Answers Type : Equal

Text Areas : PlainText

Possible Answers :

100

Question Number : 86 **Question Id :** 86435186 **Question Type :** SA

Correct Marks : 4 **Wrong Marks :** 0

Let $P = \begin{bmatrix} -30 & 20 & 56 \\ 90 & 140 & 112 \\ 120 & 60 & 14 \end{bmatrix}$ and $A = \begin{bmatrix} 2 & 7 & \omega^2 \\ -1 & -\omega & 1 \\ 0 & -\omega & -\omega+1 \end{bmatrix}$ where $\omega = \frac{-1 + i\sqrt{3}}{2}$, and I_3 be the

identity matrix of order 3. If the determinant of the matrix $(P^{-1}AP - I_3)^2$ is $\alpha\omega^2$, then the value of α is equal to _____.

Response Type : Numeric

Evaluation Required For SA : Yes

Show Word Count : Yes

Answers Type : Equal

Text Areas : PlainText

Possible Answers :

100

Question Number : 86 **Question Id :** 86435186 **Question Type :** SA

Correct Marks : 4 **Wrong Marks :** 0

ধৰা হ'ল $P = \begin{bmatrix} -30 & 20 & 56 \\ 90 & 140 & 112 \\ 120 & 60 & 14 \end{bmatrix}$ আৰু $A = \begin{bmatrix} 2 & 7 & \omega^2 \\ -1 & -\omega & 1 \\ 0 & -\omega & -\omega+1 \end{bmatrix}$ যত

$\omega = \frac{-1 + i\sqrt{3}}{2}$ আৰু I_3 এটা 3 মাত্ৰাৰ অভেদ মৌলকক্ষ। যদি $(P^{-1}AP - I_3)^2$ মৌলকক্ষটোৰ নিৰ্ণায়ক/মান $\alpha\omega^2$

তেন্তে α ৰ মান সমান হ'ব _____।

Response Type : Numeric

Evaluation Required For SA : Yes

Show Word Count : Yes

Answers Type : Equal

Text Areas : PlainText

Possible Answers :

100

Question Number : 87 **Question Id :** 86435187 **Question Type :** SA

Correct Marks : 4 **Wrong Marks :** 0

Let $f: (0, 2) \rightarrow \mathbb{R}$ be defined as $f(x) = \log_2 \left(1 + \tan \left(\frac{\pi x}{4} \right) \right)$.

Then, $\lim_{n \rightarrow \infty} \frac{2}{n} \left(f \left(\frac{1}{n} \right) + f \left(\frac{2}{n} \right) + \dots + f(1) \right)$ is equal to _____.

Response Type : Numeric

Evaluation Required For SA : Yes

Show Word Count : Yes

Answers Type : Equal

Text Areas : PlainText

Possible Answers :

100

Question Number : 87 **Question Id :** 86435187 **Question Type :** SA

Correct Marks : 4 **Wrong Marks :** 0

ধৰা হ'ল $f : (0, 2) \rightarrow \mathbb{R}$ ফলনটো বৰ্ণিত যাতে $f(x) = \log_2\left(1 + \tan\left(\frac{\pi x}{4}\right)\right)$ । তেন্তে

$\lim_{n \rightarrow \infty} \frac{2}{n} \left(f\left(\frac{1}{n}\right) + f\left(\frac{2}{n}\right) + \dots + f(1) \right)$ সমান হ'ব _____।

Response Type : Numeric

Evaluation Required For SA : Yes

Show Word Count : Yes

Answers Type : Equal

Text Areas : PlainText

Possible Answers :

100

Question Number : 88 **Question Id :** 86435188 **Question Type :** SA

Correct Marks : 4 **Wrong Marks :** 0

The total number of 3×3 matrices A having entries from the set $\{0, 1, 2, 3\}$ such that the sum of all the diagonal entries of AA^T is 9, is equal to _____.

Response Type : Numeric

Evaluation Required For SA : Yes

Show Word Count : Yes

Answers Type : Equal

Text Areas : PlainText

Possible Answers :

100

Question Number : 88 **Question Id :** 86435188 **Question Type :** SA

Correct Marks : 4 **Wrong Marks :** 0

$\{0, 1, 2, 3\}$ সংহতিটোৰ মৌলবোৰলৈ গঠিত 3×3 আকাৰৰ A মৌলকক্ষৰ সংখ্যা সমান হ'ব _____ যাতে AA^T মৌলকক্ষটোৰ আটাইবোৰ বিকৰ্ণমৌলৰ যোগফল 9 হয়।

Response Type : Numeric

Evaluation Required For SA : Yes

Show Word Count : Yes

Answers Type : Equal

Text Areas : PlainText

Possible Answers :

100

Question Number : 89 Question Id : 86435189 Question Type : SA

Correct Marks : 4 Wrong Marks : 0

Let ABCD be a square of side of unit length. Let a circle C_1 centered at A with unit radius is drawn. Another circle C_2 which touches C_1 and the lines AD and AB are tangent to it, is also drawn. Let a tangent line from the point C to the circle C_2 meet the side AB at E. If the length of EB is $\alpha + \sqrt{3} \beta$, where α, β are integers, then $\alpha + \beta$ is equal to _____.

Response Type : Numeric

Evaluation Required For SA : Yes

Show Word Count : Yes

Answers Type : Equal

Text Areas : PlainText

Possible Answers :

100

Question Number : 89 Question Id : 86435189 Question Type : SA

Correct Marks : 4 Wrong Marks : 0

ধৰা হ'ল ABCD এটা একক দৈৰ্ঘ্যৰ বৰ্গ। এক ব্যাসাৰ্ধলৈ A বিন্দুক কেন্দ্ৰ হিচাবে লৈ C_1 এটা বৃত্ত অংকন কৰা হ'ল। C_1 ক স্পৰ্শ কৰাকৈ আন এটা বৃত্ত C_2 অংকন কৰা হ'ল যত AD আৰু AB দুডাল স্পৰ্শক। ধৰা হ'ল C_2 বৃত্তৰ C বিন্দুৰ পৰা স্পৰ্শকৰেখা এটাই AB ক E বিন্দুত মিলিত হৈছে। যদি EB ৰ দৈৰ্ঘ্য $\alpha + \sqrt{3} \beta$, যত α, β অখণ্ড সংখ্যা, তেন্তে $\alpha + \beta$ সমান হ'ব _____।

Response Type : Numeric

Evaluation Required For SA : Yes

Show Word Count : Yes

Answers Type : Equal

Text Areas : PlainText

Possible Answers :

100

Question Number : 90 Question Id : 86435190 Question Type : SA

Correct Marks : 4 Wrong Marks : 0

Let the curve $y=y(x)$ be the solution of the differential equation, $\frac{dy}{dx}=2(x+1)$. If the numerical value of area bounded by the curve $y=y(x)$ and x -axis is $\frac{4\sqrt{8}}{3}$, then the value of $y(1)$ is equal to _____.

Response Type : Numeric

Evaluation Required For SA : Yes

Show Word Count : Yes

Answers Type : Equal

Text Areas : PlainText

Possible Answers :

100

Question Number : 90 **Question Id :** 86435190 **Question Type :** SA

Correct Marks : 4 **Wrong Marks :** 0

ধৰা হ'ল $\frac{dy}{dx}=2(x+1)$ অৱকলন সমীকৰণটোৰ $y=y(x)$ এটা সমাধান। যদি $y=y(x)$ বক্ৰ আৰু x -অক্ষৰ দ্বাৰা আগ্ৰবাক্ষেত্ৰৰ কালিৰ সাংখ্যিক মান $\frac{4\sqrt{8}}{3}$ হয়, তেন্তে $y(1)$ ৰ মান সমান হ'ব _____।

Response Type : Numeric

Evaluation Required For SA : Yes

Show Word Count : Yes

Answers Type : Equal

Text Areas : PlainText

Possible Answers :

100