

National Testing Agency

Question Paper Name :	B TECH EG 16th March 2021 Shift 1
Subject Name :	B TECH EG
Creation Date :	2021-03-16 14:04:31
Duration :	180
Number of Questions :	90
Total Marks :	300
Display Marks:	Yes

B TECH EG

Group Number :	1
Group Id :	86435110
Group Maximum Duration :	0
Group Minimum Duration :	180
Show Attended Group? :	No
Edit Attended Group? :	No
Break time :	0
Group Marks :	300
Is this Group for Examiner? :	No

Physics Section A

Section Id :	86435155
Section Number :	1
Section type :	Online
Mandatory or Optional :	Mandatory
Number of Questions :	20
Number of Questions to be attempted :	20
Section Marks :	80
Mark As Answered Required? :	Yes
Sub-Section Number :	1
Sub-Section Id :	86435155
Question Shuffling Allowed :	Yes

Question Number : 1 Question Id : 864351811 Question Type : MCQ Option Shuffling : Yes Is Question Mandatory : No

Correct Marks : 4 Wrong Marks : 1

For an electromagnetic wave travelling in free space, the relation between average energy densities due to electric (U_e) and magnetic (U_m) fields is :

Options :

8643512431. $U_e = U_m$

8643512432. $U_e \neq U_m$

8643512433. $U_e > U_m$

8643512434. $U_e < U_m$

Question Number : 1 Question Id : 864351811 Question Type : MCQ Option Shuffling : Yes Is Question Mandatory : No

Correct Marks : 4 Wrong Marks : 1

મુક્ત અવકાશમાં ગતિ કરતાં વિદ્યુતચુંબકીય તરંગ માટે વિદ્યુત ક્ષેત્ર અને ચુંબકીય ક્ષેત્ર ને કારણે મળતી સરેરાશ ઊર્જા ઘનતાઓ (U_e) અને (U_m) વચ્ચેનો સંબંધ _____ છે.

Options :

8643512431. $U_e = U_m$

8643512432. $U_e \neq U_m$

8643512433. $U_e > U_m$

8643512434. $U_e < U_m$

Question Number : 2 Question Id : 864351812 Question Type : MCQ Option Shuffling : Yes Is Question Mandatory : No

Correct Marks : 4 Wrong Marks : 1

The volume V of an enclosure contains a mixture of three gases, 16 g of oxygen, 28 g of nitrogen and 44 g of carbon dioxide at absolute temperature T . Consider R as universal gas constant. The pressure of the mixture of gases is :

Options :

8643512435. $\frac{5}{2} \frac{RT}{V}$

8643512436. $\frac{3RT}{V}$

8643512437. $\frac{4RT}{V}$

8643512438. $\frac{88RT}{V}$

Question Number : 2 Question Id : 864351812 Question Type : MCQ Option Shuffling : Yes Is Question Mandatory : No

Correct Marks : 4 Wrong Marks : 1

V કદ ધરાવતાં પાત્રમાં ત્રણ વાયુઓ, 16 ગ્રામ ઓક્સિજન, 28 ગ્રામ નાઈટ્રોજન અને 44 ગ્રામ કાર્બન ડાયઑક્સાઈડનું મિશ્રણ T જેટલા નિરપેક્ષ તાપમાને છે. R એ સાર્વત્રિક વાયુ અચળાંક છે. વાયુઓનાં મિશ્રણનું દબાણ _____ છે.

Options :

8643512435. $\frac{5}{2} \frac{RT}{V}$

8643512436. $\frac{3RT}{V}$

8643512437. $\frac{4RT}{V}$

8643512438. $\frac{88RT}{V}$

Question Number : 3 Question Id : 864351813 Question Type : MCQ Option Shuffling : Yes Is Question Mandatory : No

Correct Marks : 4 Wrong Marks : 1

For changing the capacitance of a given parallel plate capacitor, a dielectric material of dielectric constant K is used, which has the same area as the plates of the capacitor. The thickness of the dielectric slab is $\frac{3}{4}d$, where 'd' is the separation between the plates of parallel plate capacitor. The new capacitance (C') in terms of original capacitance (C₀) is given by the following relation :

Options :

8643512439.
$$C' = \frac{4K}{K+3}C_0$$

8643512440.
$$C' = \frac{4}{3+K}C_0$$

8643512441.
$$C' = \frac{3+K}{4K}C_0$$

8643512442.
$$C' = \frac{4+K}{3}C_0$$

Question Number : 3 Question Id : 864351813 Question Type : MCQ Option Shuffling : Yes Is Question Mandatory : No

Correct Marks : 4 Wrong Marks : 1

આપેલા સમાંતર પ્લેટ સંઘારકની સંઘારકતા બદલવવા માટે K જેટલો ડાયઈલેક્ટ્રીક (પરાવૈદ્યુતાંક) અચળાંક ધરાવતાં પદાર્થનો ઉપયોગ કરવામાં આવે છે કે જેનું ક્ષેત્રફળ સંઘારકની પ્લેટોનાં ક્ષેત્રફળ જેટલું જ છે. આ ડાયઈલેક્ટ્રીક ચોસલાની જાડાઈ $\frac{3}{4}t$ છે, જ્યાં 't' એ કેપેસિટરની બે સમાંતર પ્લેટો વચ્ચેનું અંતર છે. મૂળ સંઘારકતા (C_0) નાં પદમાં નવી સંઘારકતા (C') નીચેના _____ સંબંધથી આપી શકાય.

Options :

8643512439.
$$C' = \frac{4K}{K+3}C_0$$

8643512440.
$$C' = \frac{4}{3+K}C_0$$

8643512441.
$$C' = \frac{3+K}{4K}C_0$$

8643512442.
$$C' = \frac{4+K}{3}C_0$$

Question Number : 4 Question Id : 864351814 Question Type : MCQ Option Shuffling : Yes Is Question Mandatory : No

Correct Marks : 4 Wrong Marks : 1

The velocity-displacement graph describing the motion of a bicycle is shown in the figure.

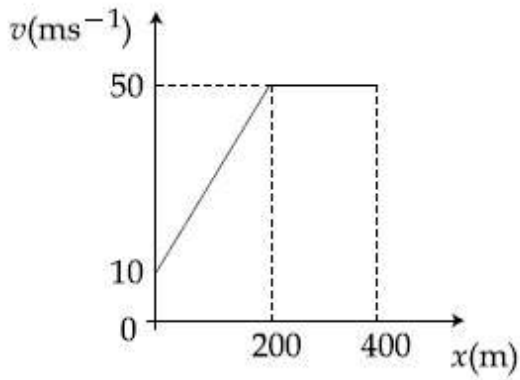

The acceleration-displacement graph of the bicycle's motion is best described by :

Options :

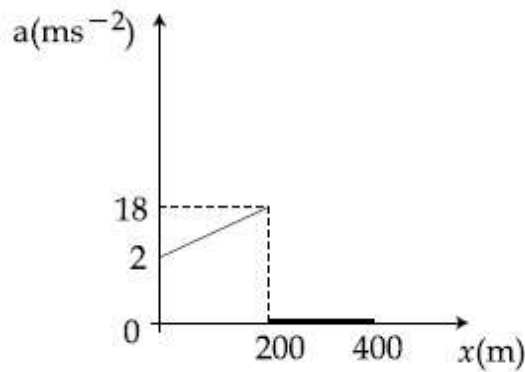

8643512443.

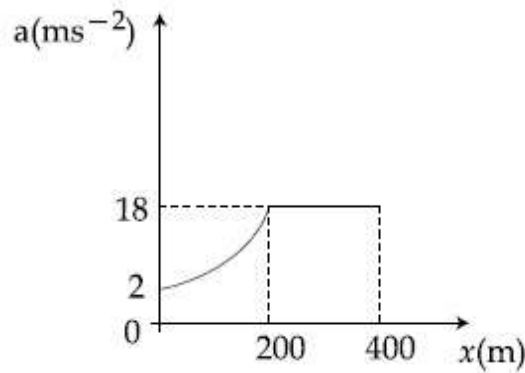

8643512444.

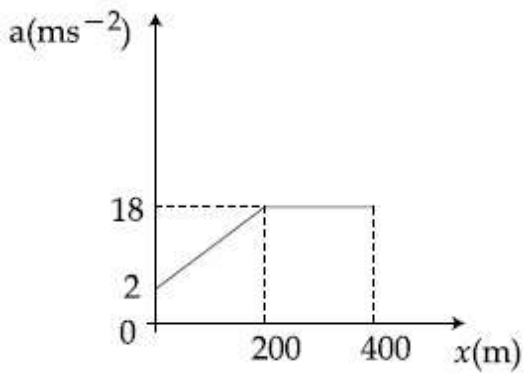

8643512445.

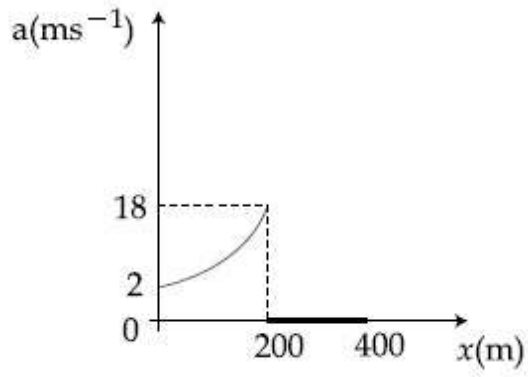

8643512446.

Question Number : 4 Question Id : 864351814 Question Type : MCQ Option Shuffling : Yes Is Question Mandatory : No

Correct Marks : 4 Wrong Marks : 1

સાઇકલની ગતિ દર્શાવતો વેગ-સ્થાનાંતરનો આલેખ આકૃતિમાં દર્શાવેલ છે.

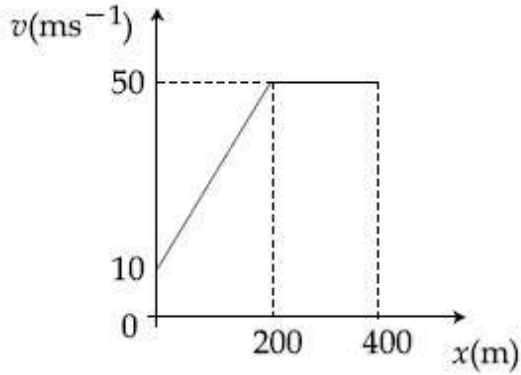

સાઇકલની ગતિનો પ્રવેગ-સ્થાનાંતરનો આલેખ સાચી રીતે _____ વડે આપી શકાય.

Options :

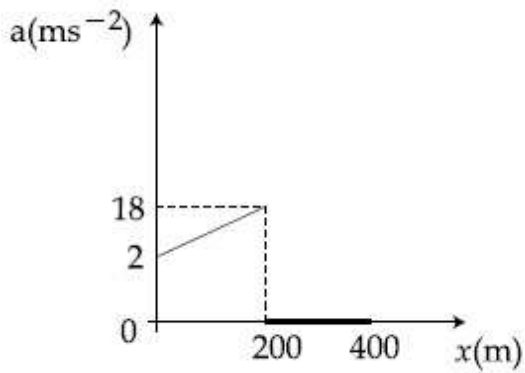

8643512443.

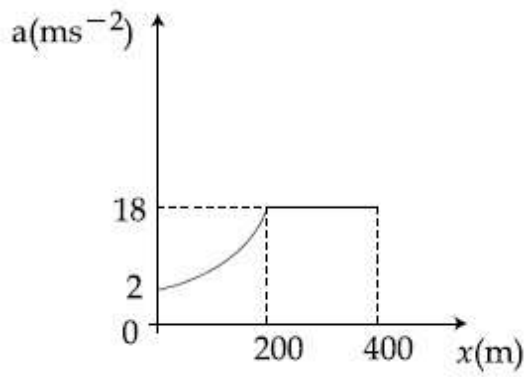

8643512444.

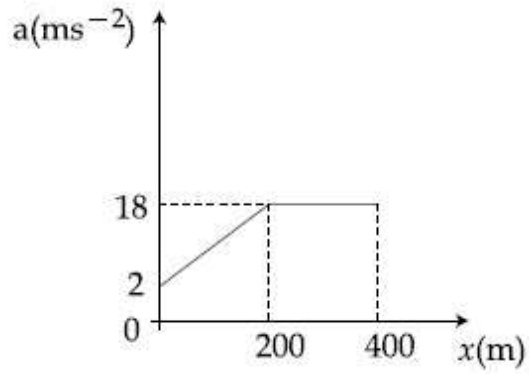

8643512445.

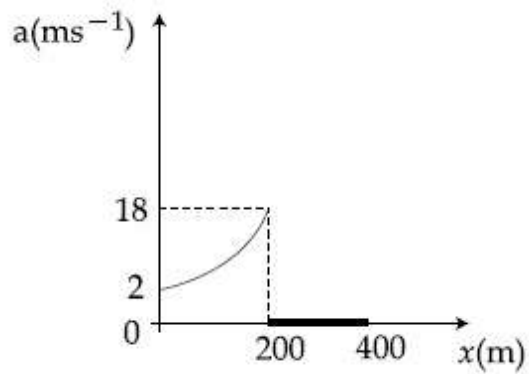

8643512446.

Question Number : 5 Question Id : 864351815 Question Type : MCQ Option Shuffling : Yes Is Question Mandatory : No Correct Marks : 4 Wrong Marks : 1

A block of mass m slides along a floor while a force of magnitude F is applied to it at an angle θ as shown in figure. The coefficient of kinetic friction is μ_K . Then, the block's acceleration 'a' is given by :

(g is acceleration due to gravity)

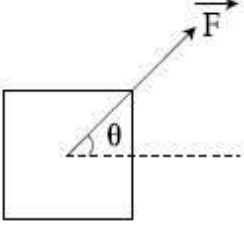

Options :

8643512447. $-\frac{F}{m}\cos\theta - \mu_K\left(g - \frac{F}{m}\sin\theta\right)$

8643512448. $\frac{F}{m}\cos\theta + \mu_K\left(g - \frac{F}{m}\sin\theta\right)$

8643512449. $\frac{F}{m}\cos\theta - \mu_K\left(g + \frac{F}{m}\sin\theta\right)$

8643512450. $\frac{F}{m}\cos\theta - \mu_K\left(g - \frac{F}{m}\sin\theta\right)$

Question Number : 5 Question Id : 864351815 Question Type : MCQ Option Shuffling : Yes Is Question Mandatory : No

Correct Marks : 4 Wrong Marks : 1

આકૃતિમાં દર્શાવ્યા અનુસાર m દળ વાળા ચોસલા પર જ્યારે F મૂલ્ય ધરવાતું બળ θ કોણે લગાવવામાં આવે છે ત્યારે તે ભોંયતળિયા પર સરકે છે. ગતિકીય ઘર્ષણાંક μ_K છે. ચોસલાનો પ્રવેગ 'a' _____ વડે આપી શકાય.

(g એ ગુરુત્વીય પ્રવેગ છે)

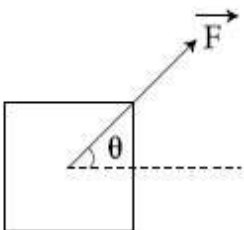

Options :

8643512447.
$$-\frac{F}{m}\cos\theta - \mu_K\left(g - \frac{F}{m}\sin\theta\right)$$

8643512448.
$$\frac{F}{m}\cos\theta + \mu_K\left(g - \frac{F}{m}\sin\theta\right)$$

8643512449.
$$\frac{F}{m}\cos\theta - \mu_K\left(g + \frac{F}{m}\sin\theta\right)$$

8643512450.
$$\frac{F}{m}\cos\theta - \mu_K\left(g - \frac{F}{m}\sin\theta\right)$$

Question Number : 6 Question Id : 864351816 Question Type : MCQ Option Shuffling : Yes Is Question Mandatory : No

Correct Marks : 4 Wrong Marks : 1

A bar magnet of length 14 cm is placed in the magnetic meridian with its north pole pointing towards the geographic north pole. A neutral point is obtained at a distance of 18 cm from the center of the magnet. If $B_H = 0.4$ G, the magnetic moment of the magnet is ($1 \text{ G} = 10^{-4}\text{T}$)

Options :

8643512451. 28.80 J T^{-1}

8643512452. $2.880 \times 10^2 \text{ J T}^{-1}$

8643512453. 2.880 J T^{-1}

8643512454. $2.880 \times 10^3 \text{ J T}^{-1}$

Question Number : 6 Question Id : 864351816 Question Type : MCQ Option Shuffling : Yes Is Question Mandatory : No

Correct Marks : 4 Wrong Marks : 1

14 cm લંબાઈ ધરાવતાં ગજીયા ચુંબકને તેનો ઉત્તર ધ્રુવ ભૌગોલીક ઉત્તર ધ્રુવ તરફ રહે તેમ ચુંબકીય ધ્રુવતલમાં મૂકવામાં આવેલ છે. ચુંબકનાં કેન્દ્રથી 18 cm અંતરે તટસ્થ બિંદુ મળે છે. જો $B_H = 0.4$ G હોય, તો ચુંબકની ચુંબકીય ચાકમાત્રા _____ હશે. ($1 \text{ G} = 10^{-4}\text{T}$)

Options :

8643512451. 28.80 J T^{-1}

8643512452. $2.880 \times 10^2 \text{ J T}^{-1}$

8643512453. 2.880 J T^{-1}

8643512454. $2.880 \times 10^3 \text{ J T}^{-1}$

Question Number : 7 Question Id : 864351817 Question Type : MCQ Option Shuffling : Yes Is Question Mandatory : No

Correct Marks : 4 Wrong Marks : 1

The angle of deviation through a prism is minimum when

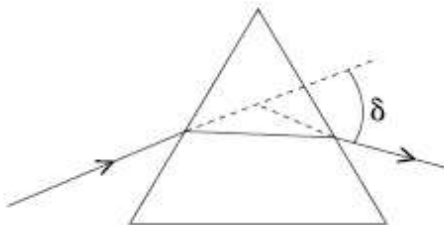

- (A) Incident ray and emergent ray are symmetric to the prism
- (B) The refracted ray inside the prism becomes parallel to its base
- (C) Angle of incidence is equal to that of the angle of emergence
- (D) When angle of emergence is double the angle of incidence

Choose the correct answer from the options given below :

Options :

8643512455. Only statements (A) and (B) are true

8643512456. Statements (A), (B) and (C) are true

8643512457. Only statement (D) is true

8643512458. Statements (B) and (C) are true

Question Number : 7 Question Id : 864351817 Question Type : MCQ Option Shuffling : Yes Is Question Mandatory : No

Correct Marks : 4 Wrong Marks : 1

પ્રિઝમમાં વિચલન કોણ લઘુત્તમ થશે જ્યારે _____.

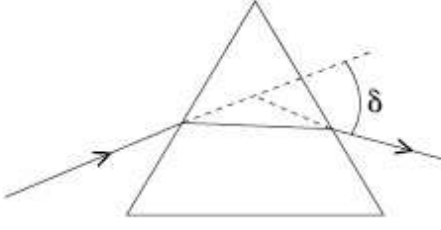

- (A) આપાત કિરણ અને નિર્ગમન કિરણ જ્યારે પ્રિઝમ સાથે સંમિતિ ધરાવે.
(B) પ્રિઝમમાં વક્રીભૂત કિરણ તેના આધાર સમાંતર બને.
(C) આપાત કોણ અને નિર્ગમન કોણ સમાન હોય.
(D) જ્યારે નિર્ગમન કોણ આપાત કોણ કરતાં બમણો થાય.

આપેલ વિકલ્પોમાંથી સાચો ઉત્તર પસંદ કરો :

Options :

8643512455. ફક્ત વિધાનો (A) અને (B) સાચાં છે.

8643512456. વિધાનો (A), (B) અને (C) સાચાં છે.

8643512457. ફક્ત વિધાન (D) સાચું છે.

8643512458. વિધાનો (B) અને (C) સાચાં છે.

Question Number : 8 Question Id : 864351818 Question Type : MCQ Option Shuffling : Yes Is Question Mandatory : No

Correct Marks : 4 Wrong Marks : 1

An RC circuit as shown in the figure is driven by a AC source generating a square wave. The output wave pattern monitored by CRO would look close to :

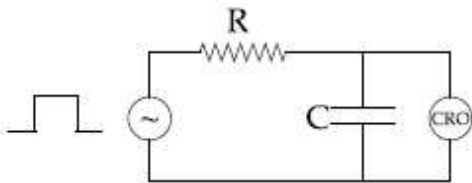

Options :

8643512459.

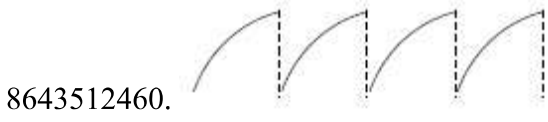

Question Number : 8 Question Id : 864351818 Question Type : MCQ Option Shuffling : Yes Is Question Mandatory : No

Correct Marks : 4 Wrong Marks : 1

આકૃતિમાં દર્શાવ્યા અનુસાર એક RC પરિપથ ચોરસ તરંગ ઉત્પન્ન કરતાં AC પરિપથ થકી કાર્યરત છે. CRO દ્વારા અવલોકતી આઉટપુટ ભાત _____ ની નજીકની દેખાશે.

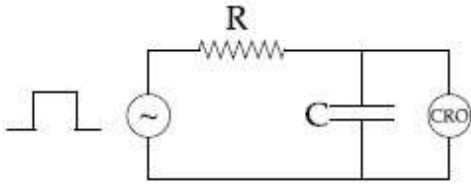

Options :

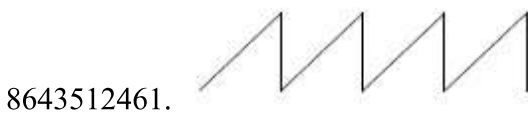
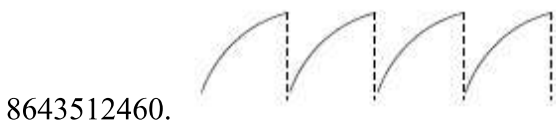

Question Number : 9 Question Id : 864351819 Question Type : MCQ Option Shuffling : Yes Is Question Mandatory : No

Correct Marks : 4 Wrong Marks : 1

A block of 200 g mass moves with a uniform speed in a horizontal circular groove, with vertical side walls of radius 20 cm. If the block takes 40 s to complete one round, the normal force by the side walls of the groove is :

Options :

8643512463. 0.0314 N

8643512464. 9.859×10^{-4} N

8643512465. 6.28×10^{-3} N

8643512466. 9.859×10^{-2} N

Question Number : 9 Question Id : 864351819 Question Type : MCQ Option Shuffling : Yes Is Question Mandatory : No

Correct Marks : 4 Wrong Marks : 1

200 g દળ ધરાવતું એક ચોસલું 20 cm ત્રિજ્યા ધરાવતી શિરોલંબ બાજુઓવાળી સમક્ષિતિજ વર્તુળાકાર બખોલમાં સમાન ઝડપે ગતિ કરે છે. જો ચોસલું એક ચક્ર પુરું કરવા 40 s સમય લગાડે તો બખોલની બાજુની દિવાલો દ્વારા લાગતું લંબ (contact) બળ _____ હશે.

Options :

8643512463. 0.0314 N

8643512464. 9.859×10^{-4} N

8643512465. 6.28×10^{-3} N

8643512466. 9.859×10^{-2} N

Question Number : 10 Question Id : 864351820 Question Type : MCQ Option Shuffling : Yes Is Question Mandatory : No

Correct Marks : 4 Wrong Marks : 1

In thermodynamics, heat and work are :

Options :

8643512467. Point functions

8643512468. Path functions

8643512469. Intensive thermodynamic state variables

8643512470. Extensive thermodynamic state variables

Question Number : 10 Question Id : 864351820 Question Type : MCQ Option Shuffling : Yes Is Question Mandatory : No

Correct Marks : 4 Wrong Marks : 1

થર્મોડાયનેમિકસમાં, ઉષ્મા અને કાર્ય _____.

Options :

8643512467. બિંદુ વિધેયો

8643512468. પથ વિધેયો

8643512469. Intensive (સઘન) થર્મોડાયનેમિક સ્થિતિ પ્રાચલો.

8643512470. Extensive (વ્યાપક) થર્મોડાયનેમિક સ્થિતિ પ્રાચલો.

Question Number : 11 Question Id : 864351821 Question Type : MCQ Option Shuffling : Yes Is Question Mandatory : No

Correct Marks : 4 Wrong Marks : 1

The maximum and minimum distances of a comet from the Sun are 1.6×10^{12} m and 8.0×10^{10} m respectively. If the speed of the comet at the nearest point is 6×10^4 ms⁻¹, the speed at the farthest point is :

Options :

8643512471. 1.5×10^3 m/s

8643512472. 3.0×10^3 m/s

8643512473. 6.0×10^3 m/s

8643512474. 4.5×10^3 m/s

Question Number : 11 Question Id : 864351821 Question Type : MCQ Option Shuffling : Yes Is Question Mandatory : No

Correct Marks : 4 Wrong Marks : 1

સૂર્યથી એક ધૂમકેતુનાં મહત્તમ અને ન્યૂનતમ અંતરો અનુક્રમે 1.6×10^{12} m અને 8.0×10^{10} m છે. જો ધૂમકેતુની નજીકતમ બિંદુ આગળ ઝડપ $6 \times 10^4 \text{ ms}^{-1}$ હોય તો સૌથી દૂરના બિંદુએ ઝડપ _____ હશે.

Options :

8643512471. $1.5 \times 10^3 \text{ m/s}$

8643512472. $3.0 \times 10^3 \text{ m/s}$

8643512473. $6.0 \times 10^3 \text{ m/s}$

8643512474. $4.5 \times 10^3 \text{ m/s}$

Question Number : 12 Question Id : 864351822 Question Type : MCQ Option Shuffling : Yes Is Question Mandatory : No

Correct Marks : 4 Wrong Marks : 1

Four equal masses, m each are placed at the corners of a square of length (l) as shown in the figure. The moment of inertia of the system about an axis passing through A and parallel to DB would be :

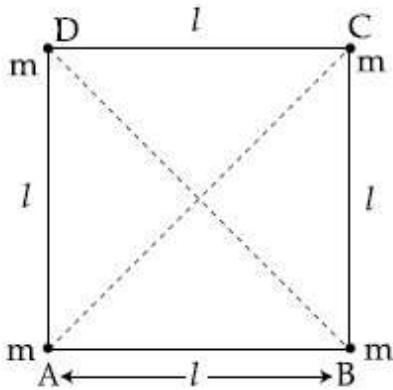

Options :

8643512475. $2 ml^2$

8643512476. $\sqrt{3} ml^2$

8643512477. $3 ml^2$

8643512478. ml^2

Question Number : 12 Question Id : 864351822 Question Type : MCQ Option Shuffling : Yes Is

Question Mandatory : No

Correct Marks : 4 Wrong Marks : 1

આકૃતિમાં દર્શાવ્યા અનુસાર, સમાન m દળ ધરાવતાં ચાર દળોને (l) લંબાઈ ધરાવતાં ચોરસના ખૂણાઓ પર મૂકવામાં આવ્યા છે. બિંદુ A માંથી પસાર થતી અને DB ને સમાંતર અક્ષને અનુલક્ષીને તંત્રની જડત્વની ચાકમાત્રા _____ થશે.

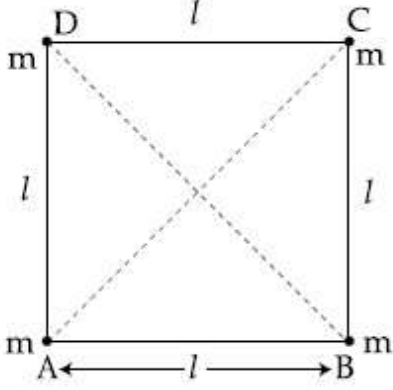

Options :

8643512475. $2 ml^2$

8643512476. $\sqrt{3} ml^2$

8643512477. $3 ml^2$

8643512478. ml^2

Question Number : 13 Question Id : 864351823 Question Type : MCQ Option Shuffling : Yes Is

Question Mandatory : No

Correct Marks : 4 Wrong Marks : 1

A 25 m long antenna is mounted on an antenna tower. The height of the antenna tower is 75 m. The wavelength (in meter) of the signal transmitted by this antenna would be :

Options :

8643512479. 200

8643512480. 300

8643512481. 400

8643512482. 100

Question Number : 13 Question Id : 864351823 Question Type : MCQ Option Shuffling : Yes Is Question Mandatory : No Correct Marks : 4 Wrong Marks : 1

એન્ટીનાં ટોવર ઉપર એક 25 m લાંબા એન્ટીનાને ગોઠવવામાં આવેલ છે. એન્ટીનાં ટાવરની ઊંચાઈ 75 m છે. આ એન્ટીનાં દ્વારા પ્રસારીત કરતાં સિગ્નલની તરંગલંબાઈ (મીટર માં) _____ છે.

Options :

8643512479. 200

8643512480. 300

8643512481. 400

8643512482. 100

Question Number : 14 Question Id : 864351824 Question Type : MCQ Option Shuffling : Yes Is Question Mandatory : No Correct Marks : 4 Wrong Marks : 1

The stopping potential in the context of photoelectric effect depends on the following property of incident electromagnetic radiation :

Options :

8643512483. Frequency

8643512484. Amplitude

8643512485. Intensity

8643512486. Phase

Question Number : 14 Question Id : 864351824 Question Type : MCQ Option Shuffling : Yes Is Question Mandatory : No Correct Marks : 4 Wrong Marks : 1

ફોટોઈલેક્ટ્રીક અસરમાં સ્થિત વિદ્યુતવિભવ (stopping potential) આપાત વિદ્યુતચુંબકીય વિકિરણના નીચે આપેલ _____ ગુણધર્મ ઉપર આધાર રાખે છે.

Options :

8643512483. आवृत्ति (Frequency)

8643512484. कंपविस्तार (Amplitude)

8643512485. तीव्रता (Intensity)

8643512486. कण (Phase)

Question Number : 15 Question Id : 864351825 Question Type : MCQ Option Shuffling : Yes Is Question Mandatory : No

Correct Marks : 4 Wrong Marks : 1

Time period of a simple pendulum is T inside a lift when the lift is stationary. If the lift moves upwards with an acceleration $g/2$, the time period of pendulum will be :

Options :

8643512487. $\frac{T}{\sqrt{3}}$

8643512488. $\sqrt{3}T$

8643512489. $\sqrt{\frac{3}{2}} T$

8643512490. $\sqrt{\frac{2}{3}} T$

Question Number : 15 Question Id : 864351825 Question Type : MCQ Option Shuffling : Yes Is Question Mandatory : No

Correct Marks : 4 Wrong Marks : 1

જ્યારે લિફ્ટ સ્થિર સ્થિતિમાં હોય ત્યારે લિફ્ટમાં સાદા લોલકનો આવર્તકાળ T છે. જો લિફ્ટ $g/2$ જેટલા પ્રવેગથી ઉપર તરફ ગતિ કરે તો લોલકનો આવર્તકાળ _____ થશે.

Options :

8643512487. $\frac{T}{\sqrt{3}}$

8643512488. $\sqrt{3}T$

8643512489. $\sqrt{\frac{3}{2}}T$

8643512490. $\sqrt{\frac{2}{3}}T$

Question Number : 16 Question Id : 864351826 Question Type : MCQ Option Shuffling : Yes Is Question Mandatory : No Correct Marks : 4 Wrong Marks : 1

A plane electromagnetic wave of frequency 500 MHz is travelling in vacuum along y -direction.

At a particular point in space and time, $\vec{B} = 8.0 \times 10^{-8} \hat{z}T$. The value of electric field at this point is :

(speed of light = $3 \times 10^8 \text{ ms}^{-1}$)

$\hat{x}, \hat{y}, \hat{z}$ are unit vectors along x, y and z directions.

Options :

8643512491. $-24 \hat{x} \text{ V/m}$

8643512492. $2.6 \hat{x} \text{ V/m}$

8643512493. $24 \hat{x} \text{ V/m}$

8643512494. $-2.6 \hat{y} \text{ V/m}$

Question Number : 16 Question Id : 864351826 Question Type : MCQ Option Shuffling : Yes Is Question Mandatory : No Correct Marks : 4 Wrong Marks : 1

શૂન્યાવકાશમાં 500 MHz આવૃત્તિ ધરાવતું એક સમતલ વિદ્યુત ચુંબકીય તરંગ y -દિશામાં ગતિ કરે છે. અવકાશનાં ચોક્કસ

બિંદુએ અને સમયે $\vec{B} = 8.0 \times 10^{-8} \hat{z} \text{ T}$ વડે અપાય છે. આ બિંદુ આગળ વિદ્યુતક્ષેત્ર _____ થશે.

(પ્રકાશની ઝડપ $= 3 \times 10^8 \text{ ms}^{-1}$)

\hat{x} , \hat{y} , \hat{z} એ x , y અને z દિશામાં એકમ સદિશો છે.

Options :

8643512491. $-24 \hat{x} \text{ V/m}$

8643512492. $2.6 \hat{x} \text{ V/m}$

8643512493. $24 \hat{x} \text{ V/m}$

8643512494. $-2.6 \hat{y} \text{ V/m}$

Question Number : 17 Question Id : 864351827 Question Type : MCQ Option Shuffling : Yes Is Question Mandatory : No

Correct Marks : 4 Wrong Marks : 1

A conducting bar of length L is free to slide on two parallel conducting rails as shown in the figure

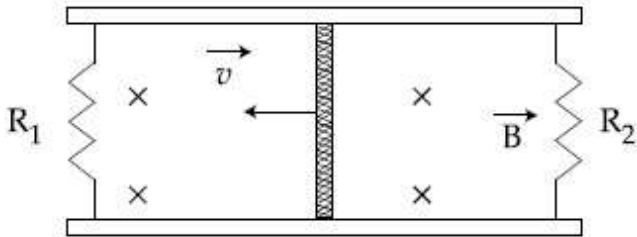

Two resistors R_1 and R_2 are connected across the ends of the rails. There is a uniform magnetic field \vec{B} pointing into the page. An external agent pulls the bar to the left at a constant speed v .

The correct statement about the directions of induced currents I_1 and I_2 flowing through R_1 and R_2 respectively is :

Options :

8643512495. I_1 is in anticlockwise direction and I_2 is in clockwise direction

8643512496. I_1 is in clockwise direction and I_2 is in anticlockwise direction

8643512497. Both I_1 and I_2 are in anticlockwise direction

8643512498. Both I_1 and I_2 are in clockwise direction

Question Number : 17 Question Id : 864351827 Question Type : MCQ Option Shuffling : Yes Is Question Mandatory : No

Correct Marks : 4 Wrong Marks : 1

આકૃતિમાં દર્શાવ્યા અનુસાર L લંબાઈનો એક સુવાહક સળિયો બે સમાંતર સુવાહક પટ્ટરી (પાટા) ઉપર મુક્ત રીતે સરકી શકે છે.

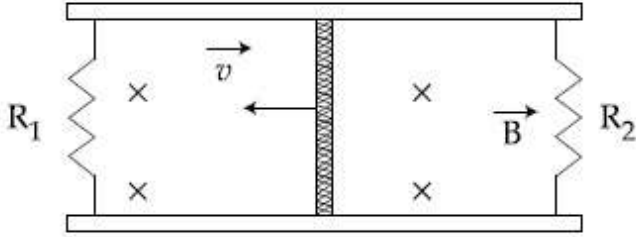

આ બે પાટાઓનાં છેડે R_1 અને R_2 અવરોધો જોડવામાં આવ્યા છે. પુસ્તકનાં પાનને લંબ અંદર તરફ સમાન ચુંબકીય ક્ષેત્ર \vec{B} પ્રવર્તે છે. બાહ્ય પરિબળ દ્વારા સળિયાને v જેટલી અચળ ઝડપથી ડાબી બાજુ ખેંચવામાં આવે છે. R_1 અને R_2 માં અનુક્રમે વહેતા પ્રેરિત પ્રવાહો I_1 અને I_2 ની દિશા માટે સાચું વિધાન _____ થશે.

Options :

8643512495. I_1 એ વિષમઘડી દિશામાં અને I_2 એ સમઘડી દિશામાં

8643512496. I_1 એ સમઘડી દિશામાં અને I_2 એ વિષમઘડી દિશામાં

8643512497. બંને I_1 અને I_2 વિષમઘડી દિશામાં

8643512498. બંને I_1 અને I_2 સમઘડી દિશામાં

Question Number : 18 Question Id : 864351828 Question Type : MCQ Option Shuffling : Yes Is Question Mandatory : No

Correct Marks : 4 Wrong Marks : 1

The pressure acting on a submarine is 3×10^5 Pa at a certain depth. If the depth is doubled, the percentage increase in the pressure acting on the submarine would be :

(Assume that atmospheric pressure is 1×10^5 Pa density of water is 10^3 kg m^{-3} , $g = 10 \text{ ms}^{-2}$)

Options :

8643512499. $\frac{5}{200}\%$

8643512500. $\frac{200}{5}\%$

8643512501. $\frac{200}{3}\%$

8643512502. $\frac{3}{200}\%$

Question Number : 18 Question Id : 864351828 Question Type : MCQ Option Shuffling : Yes Is Question Mandatory : No

Correct Marks : 4 Wrong Marks : 1

ચોક્કસ ઊંડાઈએ સબમરીન પર પ્રવર્તતું દબાણ 3×10^5 Pa છે. જો ઊંડાઈ બમણી કરવામાં આવે તો સબમરીન પર લાગતા દબાણમાં પ્રતિશત વધારો _____ હશે.

(વાતાવરણનું દબાણ 1×10^5 Pa અને પાણીની ઘનતા 10^3 kg m^{-3} ધારો, $g = 10 \text{ ms}^{-2}$)

Options :

8643512499. $\frac{5}{200}\%$

8643512500. $\frac{200}{5}\%$

8643512501. $\frac{200}{3}\%$

8643512502. $\frac{3}{200}\%$

Question Number : 19 Question Id : 864351829 Question Type : MCQ Option Shuffling : Yes Is

Question Mandatory : No

Correct Marks : 4 Wrong Marks : 1

A conducting wire of length ' l ', area of cross-section A and electric resistivity ρ is connected between the terminals of a battery. A potential difference V is developed between its ends, causing an electric current.

If the length of the wire of the same material is doubled and the area of cross-section is halved, the resultant current would be :

Options :

8643512503. $4 \frac{VA}{\rho l}$

8643512504. $\frac{1}{4} \frac{\rho l}{VA}$

8643512505. $\frac{1}{4} \frac{VA}{\rho l}$

8643512506. $\frac{3}{4} \frac{VA}{\rho l}$

Question Number : 19 Question Id : 864351829 Question Type : MCQ Option Shuffling : Yes Is

Question Mandatory : No

Correct Marks : 4 Wrong Marks : 1

' l ' લંબાઈનો, A જેટલું આડછેદનું ક્ષેત્રફળ અને ρ જેટલી અવરોધકતા ધરાવતાં એક સુવાહક તારને બેટરીનાં બે છેડા વચ્ચે જોડવામાં આવે છે. તેના છેડાઓ વચ્ચે V જેટલો વિદ્યુત સ્થિતિમાનનો તફાવત ઉત્પન્ન થાય છે. જેથી વિદ્યુતપ્રવાહ મળે છે. જો આ જ દ્રવ્યનાં તારની લંબાઈ બમણી કરવામાં આવે અને તેનો આડછેદ અડધો કરવામાં આવે તો પરિણામી પ્રવાહ _____ થશે.

Options :

8643512503. $4 \frac{VA}{\rho l}$

8643512504. $\frac{1}{4} \frac{\rho l}{VA}$

$$8643512505. \quad \frac{1}{4} \frac{VA}{\rho l}$$

$$8643512506. \quad \frac{3}{4} \frac{VA}{\rho l}$$

Question Number : 20 Question Id : 864351830 Question Type : MCQ Option Shuffling : Yes Is Question Mandatory : No

Correct Marks : 4 Wrong Marks : 1

One main scale division of a vernier callipers is 'a' cm and nth division of the vernier scale coincide with (n-1)th division of the main scale. The least count of the callipers in mm is :

Options :

$$8643512507. \quad \left(\frac{n-1}{10n} \right) a$$

$$8643512508. \quad \frac{10na}{(n-1)}$$

$$8643512509. \quad \frac{10a}{n}$$

$$8643512510. \quad \frac{10a}{(n-1)}$$

Question Number : 20 Question Id : 864351830 Question Type : MCQ Option Shuffling : Yes Is Question Mandatory : No

Correct Marks : 4 Wrong Marks : 1

વર્નિયર કેલીપર્સ પરના મુખ્ય સ્કેલ પરનો એક કાપો a cm છે અને વર્નિયર સ્કેલ પરનો n-મો કાપો મુખ્ય સ્કેલ પરના (n-1) માં કાપા સાથે બંધ બેસે છે. કેલીપર્સ માટે mm માં લઘુત્તમ માપ શક્તિ _____ છે.

Options :

$$8643512507. \quad \left(\frac{n-1}{10n} \right) a$$

$$8643512508. \quad \frac{10na}{(n-1)}$$

$$\frac{10a}{n}$$

8643512509.

$$\frac{10a}{(n-1)}$$

8643512510.

Physics Section B

Section Id :	86435156
Section Number :	2
Section type :	Online
Mandatory or Optional :	Mandatory
Number of Questions :	10
Number of Questions to be attempted :	5
Section Marks :	20
Mark As Answered Required? :	Yes
Sub-Section Number :	1
Sub-Section Id :	86435156
Question Shuffling Allowed :	Yes

Question Number : 21 Question Id : 864351831 Question Type : SA

Correct Marks : 4 Wrong Marks : 0

A sinusoidal voltage of peak value 250 V is applied to a series LCR circuit, in which $R=8 \Omega$, $L=24 \text{ mH}$ and $C=60 \mu\text{F}$. The value of power dissipated at resonant condition is 'x' kW. The value of x to the nearest integer is _____.

Response Type : Numeric

Evaluation Required For SA : Yes

Show Word Count : Yes

Answers Type : Equal

Text Areas : PlainText

Possible Answers :

100

Question Number : 21 Question Id : 864351831 Question Type : SA

Correct Marks : 4 Wrong Marks : 0

જેમાં $R=8 \Omega$, $L=24 \text{ mH}$ અને $C=60 \mu\text{F}$ હોય તેવા શ્રેણી LCR પરિપથને સમાંતર 250 V ના મહત્તમ વોલ્ટેજ ધરાવતો એક જ્યાવર્તી વોલ્ટેજ (સ્થિતિમાન) લગાડવામાં આવે છે. અનુનાદ સ્થિતિમાં વિખેરાતો પોવર (કાર્યત્વરા) 'x' kW છે. x નું મૂલ્ય, નજીકતમ પૂર્ણાંક માટે, _____ થશે.

Response Type : Numeric

Evaluation Required For SA : Yes

Show Word Count : Yes

Answers Type : Equal

Text Areas : PlainText

Possible Answers :

100

Question Number : 22 Question Id : 864351832 Question Type : SA

Correct Marks : 4 Wrong Marks : 0

Consider a frame that is made up of two thin massless rods AB and AC as shown in the figure. A vertical force \vec{P} of magnitude 100 N is applied at point A of the frame.

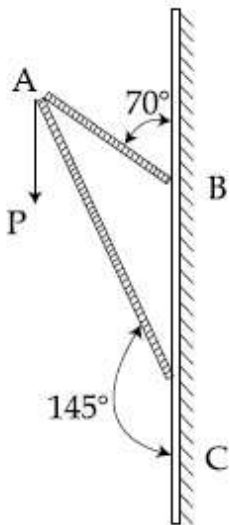

Suppose the force is \vec{P} resolved parallel to the arms AB and AC of the frame.

The magnitude of the resolved component along the arm AC is x N.

The value of x , to the nearest integer, is _____.

[Given : $\sin(35^\circ) = 0.573$, $\cos(35^\circ) = 0.819$

$\sin(110^\circ) = 0.939$, $\cos(110^\circ) = -0.342$]

Response Type : Numeric

Evaluation Required For SA : Yes

Show Word Count : Yes

Answers Type : Equal

Text Areas : PlainText

Possible Answers :

100

Question Number : 22 Question Id : 864351832 Question Type : SA

Correct Marks : 4 Wrong Marks : 0

આકૃતિમાં દર્શાવ્યા અનુસાર બે પાતળા દળરહિત સળિયાઓ AB અને AC દ્વારા બનાવેલ ફેમને ધ્યાનમાં લો. 100 N જેટલું મૂલ્ય ધરાવતું ઉર્ધ્વ બળ \vec{P} , ફેમનાં બિંદુ A આગળ લગાડવામાં આવે છે.

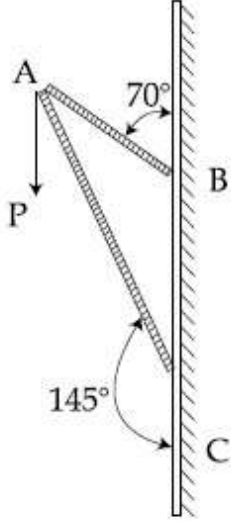

ધારો કે \vec{P} ને ફેમની ભુજાઓ AB અને AC ને સમાંતર વિભાજીત કરવામાં આવે છે. AC ભુજાને સમાંતર વિભાજીત ઘટકનું મૂલ્ય xN છે. x નું મૂલ્ય, નજીકતમ પૂર્ણાંક માટે, _____ થશે.

$$[\sin(35^\circ) = 0.573, \cos(35^\circ) = 0.819$$

$$\sin(110^\circ) = 0.939, \cos(110^\circ) = -0.342 \text{ આપેલ છે.]}$$

Response Type : Numeric

Evaluation Required For SA : Yes

Show Word Count : Yes

Answers Type : Equal

Text Areas : PlainText

Possible Answers :

100

Question Number : 23 **Question Id :** 864351833 **Question Type :** SA

Correct Marks : 4 **Wrong Marks :** 0

The first three spectral lines of H-atom in the Balmer series are given $\lambda_1, \lambda_2, \lambda_3$ considering the

Bohr atomic model, the wave lengths of first and third spectral lines $\left(\frac{\lambda_1}{\lambda_3}\right)$ are related by a

factor of approximately ' x ' $\times 10^{-1}$.

The value of x , to the nearest integer, is _____.

Response Type : Numeric

Evaluation Required For SA : Yes

Show Word Count : Yes

Answers Type : Equal

Text Areas : PlainText

Possible Answers :

100

Question Number : 23 Question Id : 864351833 Question Type : SA

Correct Marks : 4 Wrong Marks : 0

H-પરમાણુમાં બામ્ શ્રેણીમાં પ્રથમ ત્રણ વર્ણપટ રેખાઓની તરંગલંબાઈ $\lambda_1, \lambda_2, \lambda_3$ છે. બોહ્ર પરમાણુ મોડેલ અનુસાર

પ્રથમ અને તૃતીય વર્ણપટ રેખાઓ $\left(\frac{\lambda_1}{\lambda_3}\right)$, લગભગ ' x ' $\times 10^{-1}$ દ્વારા સંકળાયેલ છે. x નું મૂલ્ય, નજીકતમ પૂર્ણાંક માટે,

_____ થશે.

Response Type : Numeric

Evaluation Required For SA : Yes

Show Word Count : Yes

Answers Type : Equal

Text Areas : PlainText

Possible Answers :

100

Question Number : 24 Question Id : 864351834 Question Type : SA

Correct Marks : 4 Wrong Marks : 0

The value of power dissipated across the zener diode ($V_z = 15$ V) connected in the circuit as shown in the figure is $x \times 10^{-1}$ watt.

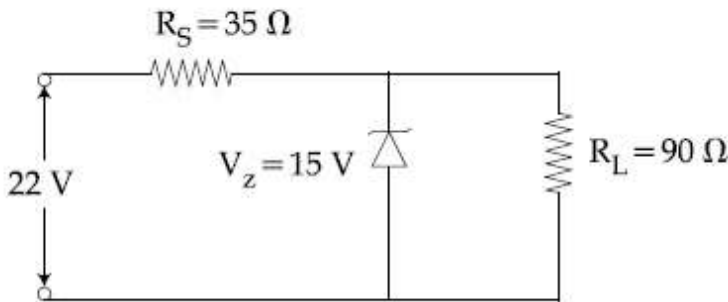

The value of x , to the nearest integer, is _____.

Response Type : Numeric

Evaluation Required For SA : Yes

Show Word Count : Yes

Answers Type : Equal

Text Areas : PlainText

Possible Answers :

100

Question Number : 24 Question Id : 864351834 Question Type : SA

Correct Marks : 4 Wrong Marks : 0

આકૃતિમાં દર્શાવ્યા અનુસાર પરિપથમાં જોડાયેલા ઝેનર ડાયોડ ($V_z = 15\text{ V}$) ને સમાંતર વિખેરીત થતી કાર્યત્વરા (પોવર) $x \times 10^{-1}$ વોટ છે.

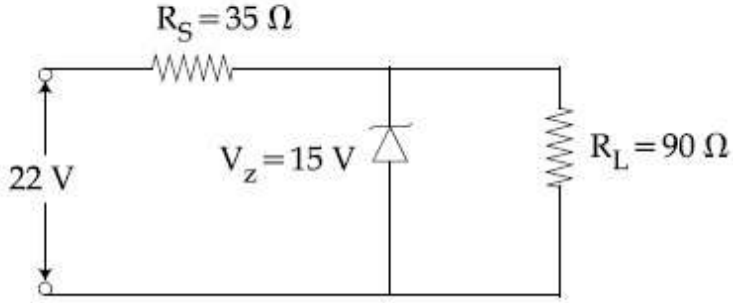

x નું મૂલ્ય, નજીકતમ પૂર્ણાંક માટે, _____ છે.

Response Type : Numeric

Evaluation Required For SA : Yes

Show Word Count : Yes

Answers Type : Equal

Text Areas : PlainText

Possible Answers :

100

Question Number : 25 Question Id : 864351835 Question Type : SA

Correct Marks : 4 Wrong Marks : 0

A ball of mass 10 kg moving with a velocity $10\sqrt{3} \text{ m s}^{-1}$ along X-axis, hits another ball of mass 20 kg which is at rest. After collision, the first ball comes to rest and the second one disintegrates into two equal pieces. One of the pieces starts moving along Y-axis at a speed of 10 m/s. The second piece starts moving at a speed of 20 m/s at an angle θ (degree) with respect to the X-axis.

The configuration of pieces after collision is shown in the figure.

The value of θ to the nearest integer is _____.

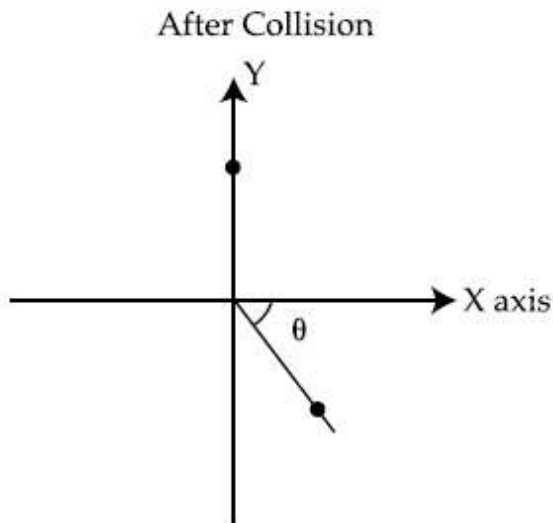

Response Type : Numeric

Evaluation Required For SA : Yes

Show Word Count : Yes

Answers Type : Equal

Text Areas : PlainText

Possible Answers :

100

Question Number : 25 **Question Id :** 864351835 **Question Type :** SA

Correct Marks : 4 **Wrong Marks :** 0

10 kg દળ ધરાવતો અને X-અક્ષની દિશામાં $10\sqrt{3} \text{ m s}^{-1}$ જેટલો વેગ ધરાવતો એક બોલ સ્થિર સ્થિતિમાં રહેલા બીજા 20 kg દળના બોલને અથડાય છે. અથડામણ બાદ, પ્રથમ બોલ સ્થિર સ્થિતિમાં આવે છે. અને બીજા બોલનાં બે એકસરખા ટુકડા થાય છે. એક ટુકડો Y-અક્ષની દિશામાં 10 m/s ગતિ કરવાનું ચાલું કરે છે. બીજો ટુકડો X-અક્ષને સાપેક્ષ θ કોણે 20 m/s થી ઝડપ સાથે ગતિ શરૂ કરે છે. અથડામણ પછીની સ્થિતિ આકૃતિમાં દર્શાવેલ છે. θ નું મૂલ્ય, નજીકતમ પૂર્ણાંક માટે, _____ થશે.

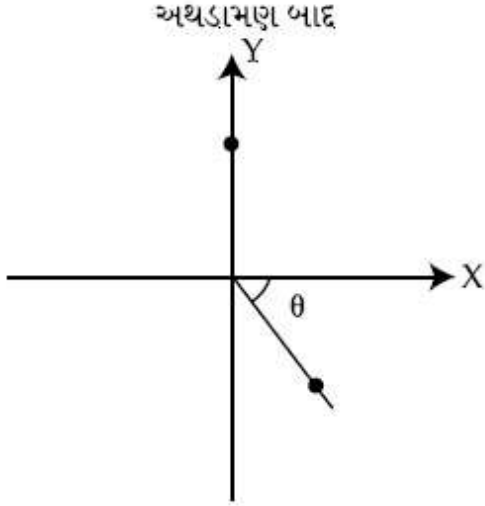

Response Type : Numeric

Evaluation Required For SA : Yes

Show Word Count : Yes

Answers Type : Equal

Text Areas : PlainText

Possible Answers :

100

Question Number : 26 **Question Id :** 864351836 **Question Type :** SA

Correct Marks : 4 **Wrong Marks :** 0

Consider a 20 kg uniform circular disk of radius 0.2 m. It is pin supported at its center and is at rest initially. The disk is acted upon by a constant force $F = 20 \text{ N}$ through a massless string wrapped around its periphery as shown in the figure.

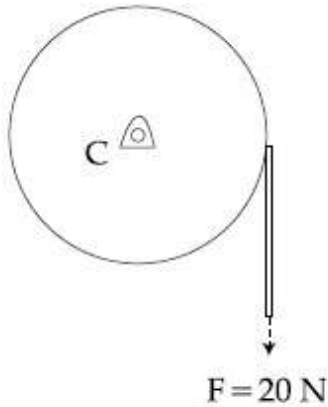

Suppose the disk makes n number of revolutions to attain an angular speed of 50 rad s^{-1} . The value of n , to the nearest integer, is _____.

[Given : In one complete revolution, the disk rotates by 6.28 rad]

Response Type : Numeric

Evaluation Required For SA : Yes

Show Word Count : Yes

Answers Type : Equal

Text Areas : PlainText

Possible Answers :

100

Question Number : 26 **Question Id :** 864351836 **Question Type :** SA

Correct Marks : 4 **Wrong Marks :** 0

0.2 m ત્રિજ્યા ધરાવતી 20 kg ની સમાંગ વર્તુળાકાર તકતિ ધ્યાનમાં લો. તેને તેના કેન્દ્ર આગળથી સ્થિર સ્થિતિમાં ટેકવેલી છે. તેને ફરતે દળરહિત દોરી વીંટાડીને આકૃતિમાં દર્શાવ્યા અનુસાર અચળ $F = 20\text{ N}$ જેટલું બળ લગાડવામાં આવે છે.

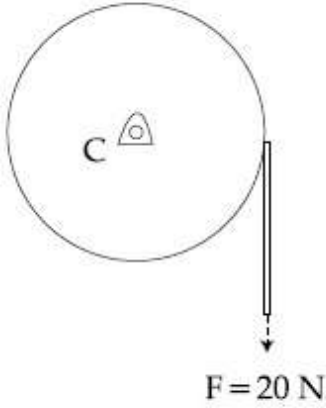

ધારો કે તકતિ n નંબરનાં પરિભ્રમણો કરી 50 rad s^{-1} જેટલી કોણીય ઝડપ પ્રાપ્ત કરે છે. n નું મૂલ્ય, નજીકતમ પૂર્ણાંક માટે, _____ થશે.

[એક પૂર્ણ પરિભ્રમણ દરમિયાન તકતિ 6.28 rad નું ભ્રમણ કરે છે.]

Response Type : Numeric

Evaluation Required For SA : Yes

Show Word Count : Yes

Answers Type : Equal

Text Areas : PlainText

Possible Answers :

100

Question Number : 27 **Question Id :** 864351837 **Question Type :** SA

Correct Marks : 4 **Wrong Marks :** 0

In the logic circuit shown in the figure, if input A and B are 0 to 1 respectively, the output at Y would be 'x'.

The value of x is _____.

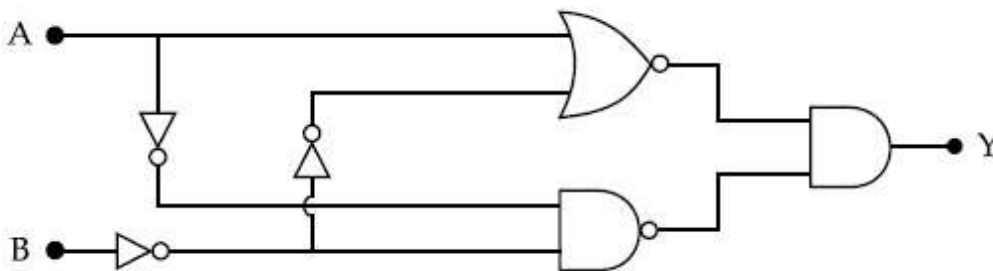

Response Type : Numeric

Evaluation Required For SA : Yes

Show Word Count : Yes

Answers Type : Equal

Text Areas : PlainText

Possible Answers :

100

Question Number : 27 Question Id : 864351837 Question Type : SA

Correct Marks : 4 Wrong Marks : 0

આકૃતિમાં દર્શાવેલ લોજિક પરિપથ માટે, જો ઈનપુટ A અને B અનુક્રમે 0 થી 1 હોય તો Y આગળ આઉટપુટ 'x' છે. x નું મૂલ્ય _____ થશે.

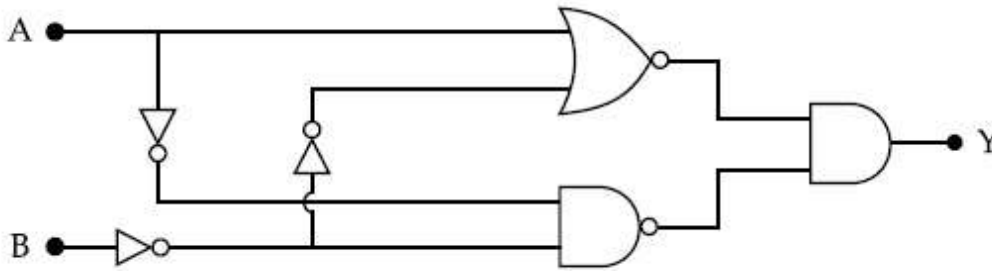

Response Type : Numeric

Evaluation Required For SA : Yes

Show Word Count : Yes

Answers Type : Equal

Text Areas : PlainText

Possible Answers :

100

Question Number : 28 Question Id : 864351838 Question Type : SA

Correct Marks : 4 Wrong Marks : 0

In the figure given, the electric current flowing through the 5 k Ω resistor is 'x' mA.

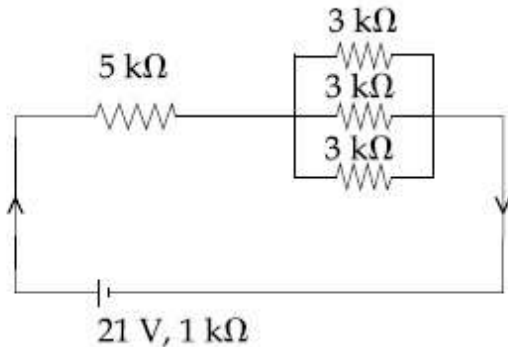

The value of x to the nearest integer is _____.

Response Type : Numeric

Evaluation Required For SA : Yes

Show Word Count : Yes

Answers Type : Equal

Text Areas : PlainText

Possible Answers :

100

Question Number : 28 Question Id : 864351838 Question Type : SA

Correct Marks : 4 Wrong Marks : 0

આપેલ પરિપથમાં, $5\text{ k}\Omega$ અવરોધમાંથી પસાર થતો વિદ્યુત પ્રવાહ ' x ' mA છે.

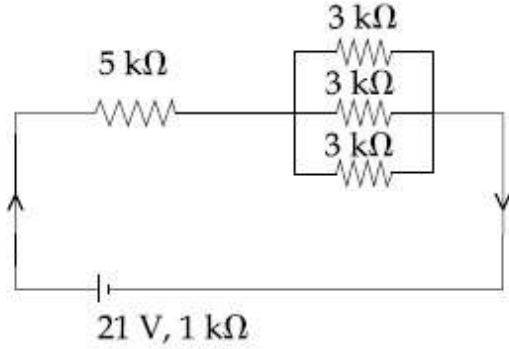

x નું મૂલ્ય, નજીકતમ પૂર્ણાંક માટે, _____ છે.

Response Type : Numeric

Evaluation Required For SA : Yes

Show Word Count : Yes

Answers Type : Equal

Text Areas : PlainText

Possible Answers :

100

Question Number : 29 Question Id : 864351839 Question Type : SA

Correct Marks : 4 Wrong Marks : 0

A fringe width of 6 mm was produced for two slits separated by 1 mm apart. The screen is placed 10 m away. The wavelength of light used is ' x ' nm.

The value of ' x ' to the nearest integer is _____.

Response Type : Numeric

Evaluation Required For SA : Yes

Show Word Count : Yes

Answers Type : Equal

Text Areas : PlainText

Possible Answers :

100

Question Number : 29 Question Id : 864351839 Question Type : SA

Correct Marks : 4 Wrong Marks : 0

1 mm અંતરે રહેલ બે સ્લિટો દ્વારા ઉત્પન્ન શલાકાની પહોળાઈ 6 mm છે. પડદો 10 m દૂર રાખેલ છે. વ્યસ્થિત પ્રકાશની તરંગલંબાઈ 'x' nm છે. 'x' નું મૂલ્ય, નજીકતમ પૂર્ણાંક માટે, _____ છે.

Response Type : Numeric

Evaluation Required For SA : Yes

Show Word Count : Yes

Answers Type : Equal

Text Areas : PlainText

Possible Answers :

100

Question Number : 30 **Question Id :** 864351840 **Question Type :** SA

Correct Marks : 4 **Wrong Marks :** 0

The resistance $R = \frac{V}{I}$, where $V = (50 \pm 2)V$ and $I = (20 \pm 0.2)A$. The percentage error in R is

'x' %.

The value of 'x' to the nearest integer is _____.

Response Type : Numeric

Evaluation Required For SA : Yes

Show Word Count : Yes

Answers Type : Equal

Text Areas : PlainText

Possible Answers :

100

Question Number : 30 **Question Id :** 864351840 **Question Type :** SA

Correct Marks : 4 **Wrong Marks :** 0

અવરોધ $R = \frac{V}{I}$, જ્યાં $V = (50 \pm 2)V$ અને $I = (20 \pm 0.2)A$ છે. R માં પ્રતિશત ત્રુટિ 'x' % છે. 'x' નું મૂલ્ય,

નજીકતમ પૂર્ણાંક માટે, _____ છે.

Response Type : Numeric

Evaluation Required For SA : Yes

Show Word Count : Yes

Answers Type : Equal

Text Areas : PlainText

Possible Answers :

100

Chemistry Section A

Section Id :	86435157
Section Number :	3
Section type :	Online
Mandatory or Optional :	Mandatory
Number of Questions :	20
Number of Questions to be attempted :	20
Section Marks :	80
Mark As Answered Required? :	Yes
Sub-Section Number :	1
Sub-Section Id :	86435157
Question Shuffling Allowed :	Yes

Question Number : 31 Question Id : 864351841 Question Type : MCQ Option Shuffling : Yes Is Question Mandatory : No Correct Marks : 4 Wrong Marks : 1

Given below are two statements : one is labelled as Assertion A and the other is labelled as Reason R :

Assertion A : The H–O–H bond angle in water molecule is 104.5° .

Reason R : The lone pair - lone pair repulsion of electrons is higher than the bond pair - bond pair repulsion.

In the light of the above statements, choose the correct answer from the options given below :

Options :

8643512521. Both A and R are true, and R is the correct explanation of A

8643512522. Both A and R are true, but R is not the correct explanation of A

8643512523. A is true but R is false

8643512524. A is false but R is true

Question Number : 31 Question Id : 864351841 Question Type : MCQ Option Shuffling : Yes Is Question Mandatory : No Correct Marks : 4 Wrong Marks : 1

નીચે બે વિધાનો આપેલા છે. એકને કથન A અને બીજાને કારણ R તરીકે લેબલ કરેલ છે.

કથન A : પાણીનાં અણુમાં H-O-H બંધખૂણો 104.5° છે.

કારણ R : ઈલેક્ટ્રોનોનું અબંધકારક-અબંધકારક અપાકર્ષણ એ બંધકારક-બંધકારક અપાકર્ષણ કરતાં વધારે હોય છે.

ઉપરનાં વિધાનોનાં સંદર્ભમાં, નીચે આપેલા વિકલ્પોમાંથી સાચો જવાબ પસંદ કરો.

Options :

8643512521. બંને A અને R સાચાં છે અને R એ A ની સાચી સમજૂતી છે

8643512522. બંને A અને R સાચાં છે પણ R એ A ની સાચી સમજૂતી નથી.

8643512523. A સાચું છે પણ R ખોટું છે.

8643512524. A ખોટું છે પણ R સાચું છે.

Question Number : 32 Question Id : 864351842 Question Type : MCQ Option Shuffling : Yes Is Question Mandatory : No

Correct Marks : 4 Wrong Marks : 1

Match List - I with List - II :

List - I	List - II
Industrial process	Application
(a) Haber's process	(i) HNO_3 synthesis
(b) Ostwald's process	(ii) Aluminium extraction
(c) Contact process	(iii) NH_3 synthesis
(d) Hall-Heroult process	(iv) H_2SO_4 synthesis

Choose the correct answer from the options given below :

Options :

8643512525. (a)-(iv), (b)-(i), (c)-(ii), (d)-(iii)

8643512526. (a)-(iii), (b)-(i), (c)-(iv), (d)-(ii)

8643512527. (a)-(ii), (b)-(iii), (c)-(iv), (d)-(i)

8643512528. (a)-(iii), (b)-(iv), (c)-(i), (d)-(ii)

Question Number : 32 Question Id : 864351842 Question Type : MCQ Option Shuffling : Yes Is Question Mandatory : No

Correct Marks : 4 Wrong Marks : 1

સૂચિ - I સાથે સૂચિ - II ને જોડો.

સૂચિ - I

ઔદ્યોગિક પ્રક્રમો

(a) હેબર પ્રક્રમ

(b) ઓસ્વાલ્ડ પ્રક્રમ

(c) સંપર્ક પ્રક્રમ

(d) હોલ-હેરોલ્ટ પ્રક્રમ

સૂચિ - II

ઉપયોગિતા

(i) HNO_3 સંશ્લેષણ

(ii) એલ્યુમિનિયમ નિષ્કર્ષણ

(iii) NH_3 સંશ્લેષણ

(iv) H_2SO_4 સંશ્લેષણ

નીચે આપેલા વિકલ્પોમાંથી સાચો જવાબ પસંદ કરો.

Options :

8643512525. (a)-(iv), (b)-(i), (c)-(ii), (d)-(iii)

8643512526. (a)-(iii), (b)-(i), (c)-(iv), (d)-(ii)

8643512527. (a)-(ii), (b)-(iii), (c)-(iv), (d)-(i)

8643512528. (a)-(iii), (b)-(iv), (c)-(i), (d)-(ii)

Question Number : 33 Question Id : 864351843 Question Type : MCQ Option Shuffling : Yes Is Question Mandatory : No

Correct Marks : 4 Wrong Marks : 1

A group 15 element, which is a metal and forms a hydride with strongest reducing power among group 15 hydrides. The element is :

Options :

8643512529. Bi

8643512530. P

8643512531. As

8643512532. Sb

Question Number : 33 Question Id : 864351843 Question Type : MCQ Option Shuffling : Yes Is Question Mandatory : No

Correct Marks : 4 Wrong Marks : 1

સમૂહ 15 નાં તત્વો કે જે ધાતુ છે અને સમૂહ 15 હાઈડ્રાઈડો પૈકી પ્રબળ રિડ્યુસીંગ શક્તિ (સામર્થ્ય)વાળો હાઈડ્રાઈડ બનાવે છે તે તત્વ શોધો :

Options :

8643512529. Bi

8643512530. P

8643512531. As

8643512532. Sb

Question Number : 34 Question Id : 864351844 Question Type : MCQ Option Shuffling : Yes Is Question Mandatory : No

Correct Marks : 4 Wrong Marks : 1

The process that involves the removal of sulphur from the ores is :

Options :

8643512533. Refining

8643512534. Roasting

8643512535. Smelting

8643512536. Leaching

Question Number : 34 Question Id : 864351844 Question Type : MCQ Option Shuffling : Yes Is Question Mandatory : No

Correct Marks : 4 Wrong Marks : 1

અયસ્કોમાંથી સલ્ફરને દૂર કરવા માટે સંકળાયેલ પ્રક્રમ જણાવો :

Options :

8643512533. શુદ્ધિકરણ

8643512534. ભૂંજન

8643512535. પ્રદ્રાવણ

8643512536. પ્રવાહિત નિક્ષાલન

Question Number : 35 Question Id : 864351845 Question Type : MCQ Option Shuffling : Yes Is Question Mandatory : No

Correct Marks : 4 Wrong Marks : 1

Given below are two statements :

Statement I : H_2O_2 can act as both oxidising and reducing agent in basic medium.

Statement II : In the hydrogen economy, the energy is transmitted in the form of dihydrogen.

In the light of the above statements, choose the correct answer from the options given below :

Options :

8643512537. Both statement I and statement II are true

8643512538. Both statement I and statement II are false

8643512539. Statement I is true but statement II is false

8643512540. Statement I is false but statement II is true

Question Number : 35 Question Id : 864351845 Question Type : MCQ Option Shuffling : Yes Is Question Mandatory : No

Correct Marks : 4 Wrong Marks : 1

નીચે બે વિધાનો આપેલા છે.

વિધાન I : બેઝિક માધ્યમમાં H_2O_2 એ ઓક્સિડેશન અને રિડક્શનકર્તા તરીકે વર્તે છે.

વિધાન II : હાઈડ્રોજન અર્થતંત્રમાં, ડાયહાઈડ્રોજનનાં સ્વરૂપમાં ઊર્જાનું પરાગમન (transmitted) થાય છે.

ઉપરનાં વિધાનોનાં સંદર્ભમાં, નીચે આપેલા વિકલ્પોમાંથી સાચો જવાબ પસંદ કરો.

Options :

8643512537. બંને વિધાન I અને વિધાન II સાચાં છે.

8643512538. બંને વિધાન I અને વિધાન II ખોટા છે.

8643512539. વિધાન I સાચું છે પણ વિધાન II ખોટું છે.

8643512540. વિધાન I ખોટું છે પણ વિધાન II સાચું છે.

Question Number : 36 Question Id : 864351846 Question Type : MCQ Option Shuffling : Yes Is Question Mandatory : No

Correct Marks : 4 Wrong Marks : 1

Given below are two statements :

Statement I : Both $\text{CaCl}_2 \cdot 6\text{H}_2\text{O}$ and $\text{MgCl}_2 \cdot 8\text{H}_2\text{O}$ undergo dehydration on heating.

Statement II : BeO is amphoteric whereas the oxides of other elements in the same group are acidic.

In the light of the above statements, choose the correct answer from the options given below :

Options :

8643512541. Both statement I and statement II are true

8643512542. Both statement I and statement II are false

8643512543. Statement I is true but statement II is false

8643512544. Statement I is false but statement II is true

Question Number : 36 Question Id : 864351846 Question Type : MCQ Option Shuffling : Yes Is Question Mandatory : No

Correct Marks : 4 Wrong Marks : 1

નીચે બે વિધાનો આપેલા છે.

વિધાન I : ગરમ કરતાં બંને $\text{CaCl}_2 \cdot 6\text{H}_2\text{O}$ અને $\text{MgCl}_2 \cdot 8\text{H}_2\text{O}$ નિર્જલીકરણ પામે છે.

વિધાન II : BeO એ ઉભયગુણી છે જ્યારે તે જ સમૂહનાં બીજા તત્ત્વોનાં ઓક્સાઈડો એસિડિક છે.

ઉપરનાં વિધાનોનાં સંદર્ભમાં, નીચે આપેલા વિકલ્પોમાંથી સાચો જવાબ પસંદ કરો.

Options :

8643512541. બંને વિધાન I અને વિધાન II સાચાં છે.

8643512542. બંને વિધાન I અને વિધાન II ખોટા છે.

8643512543. વિધાન I સાચું છે પણ વિધાન II ખોટું છે.

8643512544. વિધાન I ખોટું છે પણ વિધાન II સાચું છે.

Question Number : 37 Question Id : 864351847 Question Type : MCQ Option Shuffling : Yes Is Question Mandatory : No

Correct Marks : 4 Wrong Marks : 1

Match List - I with List - II :

List - I		List - II	
Name of oxo acid		Oxidation state of 'P'	
(a) Hypophosphorous acid	(i)	+5	
(b) Orthophosphoric acid	(ii)	+4	
(c) Hypophosphoric acid	(iii)	+3	
(d) Orthophosphorous acid	(iv)	+2	
	(v)	+1	

Choose the correct answer from the options given below :

Options :

8643512545. (a)-(v), (b)-(iv), (c)-(ii), (d)-(iii)

8643512546. (a)-(iv), (b)-(i), (c)-(ii), (d)-(iii)

8643512547. (a)-(iv), (b)-(v), (c)-(ii), (d)-(iii)

8643512548. (a)-(v), (b)-(i), (c)-(ii), (d)-(iii)

Question Number : 37 Question Id : 864351847 Question Type : MCQ Option Shuffling : Yes Is Question Mandatory : No

Correct Marks : 4 Wrong Marks : 1

સૂચિ - I સાથે સૂચિ - II ને જોડો.

સૂચિ - I	સૂચિ - II
ઓક્સિડેશન અવસ્થા	P' ની ઓક્સિડેશન અવસ્થા
(a) હાઈપોફોસ્ફોરસ એસિડ	(i) + 5
(b) ઓર્થોફોસ્ફોરિક એસિડ	(ii) + 4
(c) હાઈપોફોસ્ફોરિક એસિડ	(iii) + 3
(d) ઓર્થોફોસ્ફોરસ એસિડ	(iv) + 2
	(v) + 1

નીચે આપેલા વિકલ્પોમાંથી સાચો જવાબ પસંદ કરો.

Options :

8643512545. (a)-(v), (b)-(iv), (c)-(ii), (d)-(iii)

8643512546. (a)-(iv), (b)-(i), (c)-(ii), (d)-(iii)

8643512547. (a)-(iv), (b)-(v), (c)-(ii), (d)-(iii)

8643512548. (a)-(v), (b)-(i), (c)-(ii), (d)-(iii)

Question Number : 38 Question Id : 864351848 Question Type : MCQ Option Shuffling : Yes Is Question Mandatory : No

Correct Marks : 4 Wrong Marks : 1

Given below are two statement : one is labelled as Assertion A and the other is labelled as Reason R :

Assertion A : Size of Bk^{3+} ion is less than Np^{3+} ion.

Reason R : The above is a consequence of the lanthanoid contraction.

In the light of the above statements, choose the correct answer from the options given below :

Options :

8643512549. Both A and R are true and R is the correct explanation of A

8643512550. Both A and R are true but R is not the correct explanation of A

8643512551. A is true but R is false

8643512552. A is false but R is true

Question Number : 38 Question Id : 864351848 Question Type : MCQ Option Shuffling : Yes Is Question Mandatory : No

Correct Marks : 4 Wrong Marks : 1

નીચે બે વિધાનો આપેલા છે. એક ને કથન A અને બીજાને કારણ R તરીકે લેબલ કરેલ છે.

કથન A : Bk^{3+} આયનનું કદ Np^{3+} આયન કરતાં ઓછું છે.

કારણ R : ઉપરનું એ લેન્થેનોઈડ સંકોચનનું પરિણામ (consequence) છે.

ઉપરનાં વિધાનોનાં સંદર્ભમાં, નીચે આપેલા વિકલ્પોમાં સાચો જવાબ પસંદ કરો.

Options :

8643512549. બંને A અને R સાચાં છે અને R એ A ની સાચી સમજૂતી છે.

8643512550. બંને A અને R સાચાં છે અને R એ A ની સાચી સમજૂતી નથી.

8643512551. A સાચું છે પણ R ખોટું છે.

8643512552. A ખોટું છે પણ R સાચું છે.

Question Number : 39 Question Id : 864351849 Question Type : MCQ Option Shuffling : Yes Is Question Mandatory : No

Correct Marks : 4 Wrong Marks : 1

Given below are two statements :

Statement I : The E° value for Ce^{4+}/Ce^{3+} is +1.74 V.

Statement II : Ce is more stable in Ce^{4+} state than Ce^{3+} state.

In the light of the above statements, choose the most appropriate answer from the options given below :

Options :

8643512553. Both statement I and statement II are correct

8643512554. Both statement I and statement II are incorrect

8643512555. Statement I is correct but statement II is incorrect

8643512556. Statement I is incorrect but statement II is correct

Question Number : 39 Question Id : 864351849 Question Type : MCQ Option Shuffling : Yes Is Question Mandatory : No

Correct Marks : 4 Wrong Marks : 1

નીચે બે વિધાનો આપેલા છે.

વિધાન I : Ce^{4+}/Ce^{3+} માટે E° મૂલ્ય +1.74 V છે.

વિધાન II : Ce એ, Ce^{4+} અવસ્થામાં Ce^{3+} અવસ્થા કરતાં વધારે સ્થાયી છે.

ઉપરનાં વિધાનોનાં સંદર્ભમાં, નીચે આપેલા વિકલ્પોમાંથી સૌથી વધુ અંધબેસતો જવાબ પસંદ કરો.

Options :

8643512553. બંને વિધાન I અને વિધાન II સાચાં છે.

8643512554. બંને વિધાન I અને વિધાન II ખોટા છે.

8643512555. વિધાન I સાચું છે પણ વિધાન II ખોટું છે.

8643512556. વિધાન I ખોટું છે પણ વિધાન II સાચું છે.

Question Number : 40 Question Id : 864351850 Question Type : MCQ Option Shuffling : Yes Is Question Mandatory : No

Correct Marks : 4 Wrong Marks : 1

The type of pollution that gets increased during the day time and in the presence of O_3 is :

Options :

8643512557. Reducing smog

8643512558. Oxidising smog

8643512559. Acid rain

8643512560. Global warming

Question Number : 40 Question Id : 864351850 Question Type : MCQ Option Shuffling : Yes Is Question Mandatory : No

Correct Marks : 4 Wrong Marks : 1

O₃ ની હાજરીમાં દિવસ દરમ્યાન વધતું પ્રદૂષણનો પ્રકાર શોધો.

Options :

8643512557. રિડ્યુસીંગ ધૂમ્ર-ધુમ્મસ
8643512558. ઓક્સિડાઈસીંગ ધૂમ્ર-ધુમ્મસ
8643512559. એસિડ વર્ષા
8643512560. ઓબલ વાર્મિંગ (વૈશ્વિક તાપમાન)

Question Number : 41 Question Id : 864351851 Question Type : MCQ Option Shuffling : Yes Is Question Mandatory : No

Correct Marks : 4 Wrong Marks : 1

In chromatography technique, the purification of compound is independent of :

Options :

8643512561. Solubility of the compound
8643512562. Mobility or flow of solvent system
8643512563. Length of the column or TLC plate
8643512564. Physical state of the pure compound

Question Number : 41 Question Id : 864351851 Question Type : MCQ Option Shuffling : Yes Is Question Mandatory : No

Correct Marks : 4 Wrong Marks : 1

ક્રોમેટોગ્રાફી (વર્ણાનુલેખી) તકનિકીમાં, સંયોજનનું શુદ્ધિકરણ સ્વતંત્ર છે જે _____.

Options :

8643512561. સંયોજનની દ્રાવ્યતા
8643512562. દ્રાવક પ્રણાલીનું વહન અથવા પ્રવાહ
8643512563. કોલમ (સ્તંભ)ની લંબાઈ અથવા TLC પ્લેટ

8643512564. शुद्ध संयोजननी भौतिक अवस्था

Question Number : 42 Question Id : 864351852 Question Type : MCQ Option Shuffling : Yes Is Question Mandatory : No

Correct Marks : 4 Wrong Marks : 1

Among the following, the aromatic compounds are :

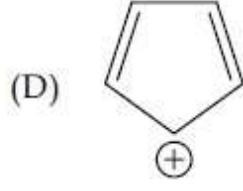
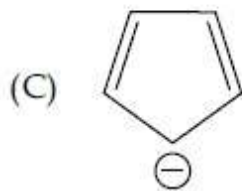
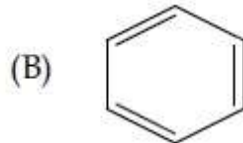
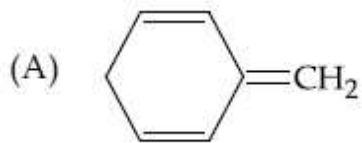

Choose the correct answer from the following options :

Options :

8643512565. (A) and (B) only

8643512566. (A), (B) and (C) only

8643512567. (B), (C) and (D) only

8643512568. (B) and (C) only

Question Number : 42 Question Id : 864351852 Question Type : MCQ Option Shuffling : Yes Is Question Mandatory : No

Correct Marks : 4 Wrong Marks : 1

નીચે આપેલા પૈકી, એરોમેટિક સંયોજનો શોધો.

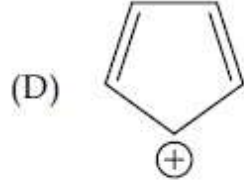
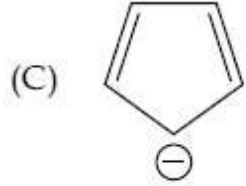
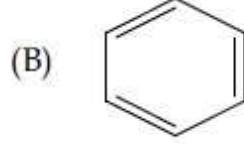

નીચે આપેલા વિકલ્પોમાંથી સાચો જવાબ પસંદ કરો :

Options :

8643512565. ફક્ત (A) અને (B)

8643512566. ફક્ત (A), (B) અને (C)

8643512567. ફક્ત (B), (C) અને (D)

8643512568. ફક્ત (B) અને (C)

Question Number : 43 Question Id : 864351853 Question Type : MCQ Option Shuffling : Yes Is

Question Mandatory : No

Correct Marks : 4 Wrong Marks : 1

Which of the following is Lindlar catalyst ?

Options :

8643512569. Partially deactivated palladised charcoal

8643512570. Sodium and Liquid NH_3

8643512571. Cold dilute solution of KMnO_4

8643512572. Zinc chloride and HCl

Question Number : 43 Question Id : 864351853 Question Type : MCQ Option Shuffling : Yes Is

Question Mandatory : No

Correct Marks : 4 Wrong Marks : 1

નીચે આપેલામાંથી કયો લીન્ડલર ઉદ્દીપક છે ?

Options :

8643512569. આંશિક અક્રિય (સક્રિય ન હોય) પેલેડાઈસ ચારકોલ

8643512570. સોડિયમ અને પ્રવાહી NH_3

8643512571. KMnO_4 નું ઠંડું મંદ દ્રાવણ

8643512572. ઝિંક ક્લોરાઈડ અને HCl

Question Number : 44 Question Id : 864351854 Question Type : MCQ Option Shuffling : Yes Is

Question Mandatory : No

Correct Marks : 4 Wrong Marks : 1

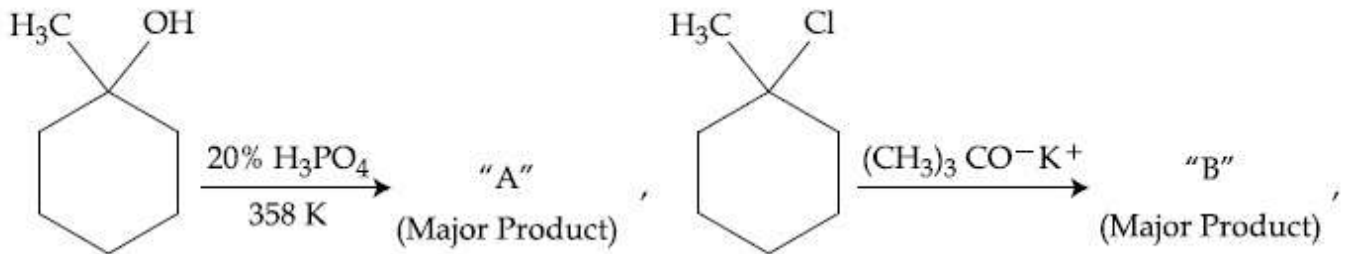

The products "A" and "B" formed in above reactions are :

Options :

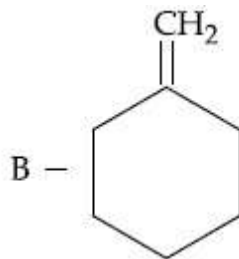
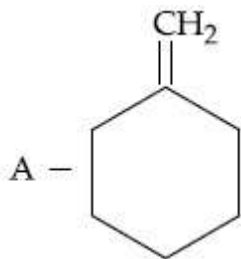

8643512573.

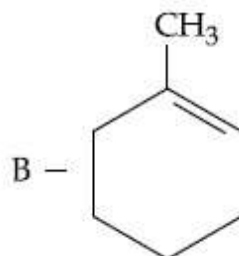
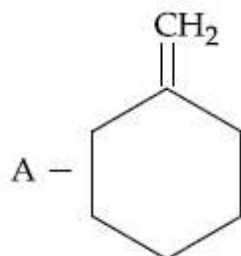

8643512574.

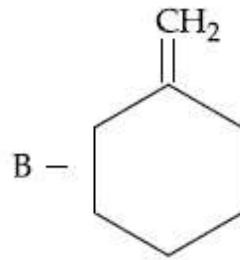
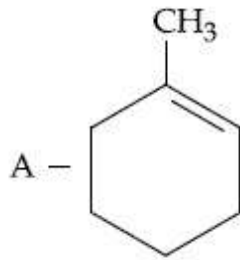

8643512575.

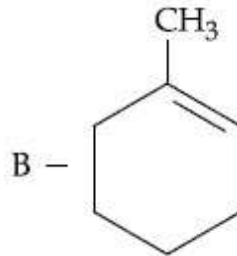
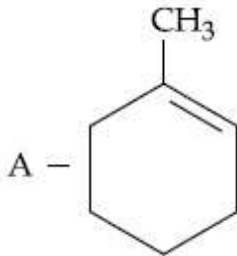

8643512576.

Question Number : 44 Question Id : 864351854 Question Type : MCQ Option Shuffling : Yes Is Question Mandatory : No

Correct Marks : 4 Wrong Marks : 1

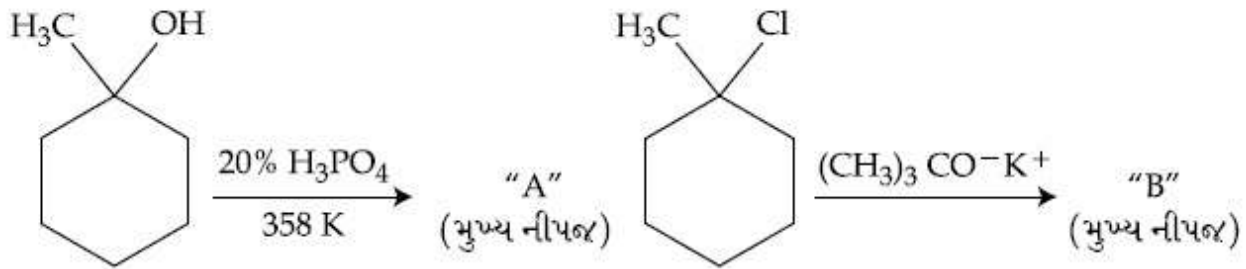

ઉપરની પ્રક્રિયામાં બનતી નીપજો "A" અને "B" શોધો.

Options :

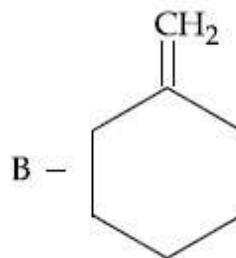
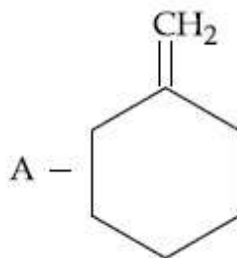

8643512573.

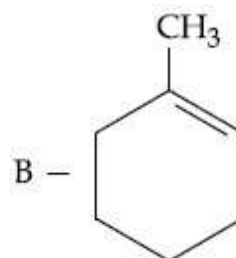
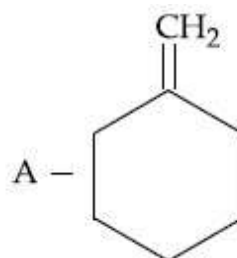

8643512574.

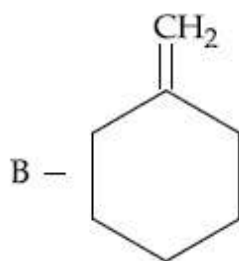
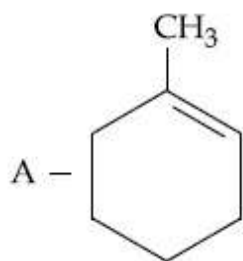

8643512575.

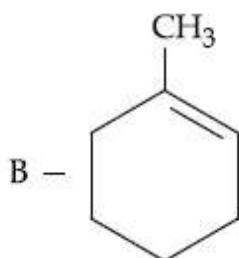
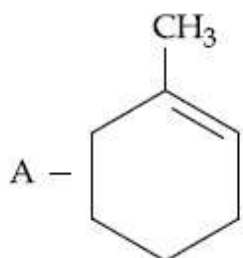

8643512576.

Question Number : 45 Question Id : 864351855 Question Type : MCQ Option Shuffling : Yes Is Question Mandatory : No Correct Marks : 4 Wrong Marks : 1

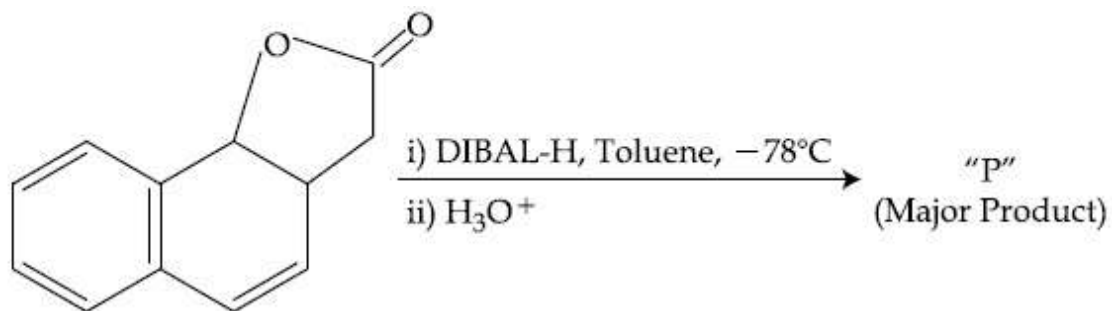

The product "P" in the above reaction is :

Options :

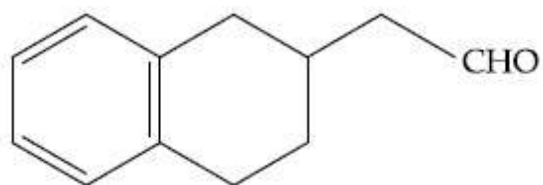

8643512577.

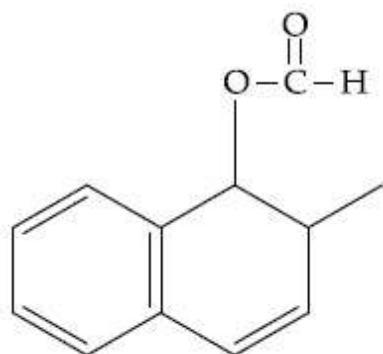

8643512578.

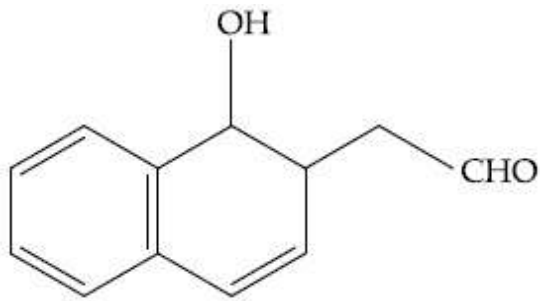

8643512579.

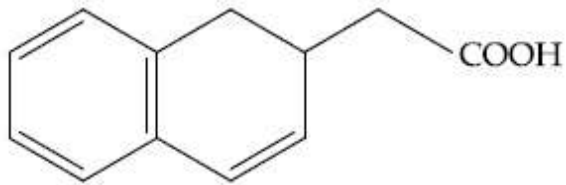

8643512580.

Question Number : 45 Question Id : 864351855 Question Type : MCQ Option Shuffling : Yes Is Question Mandatory : No

Correct Marks : 4 Wrong Marks : 1

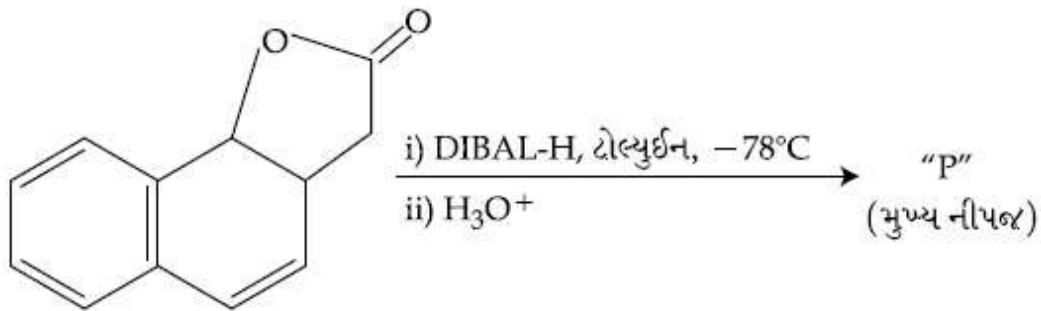

ઉપરની પ્રક્રિયામાં નીપજ "P" શોધો.

Options :

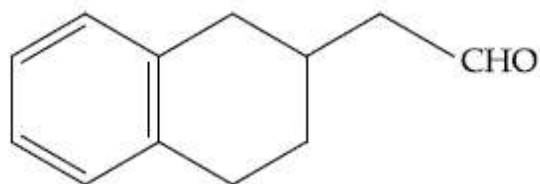

8643512577.

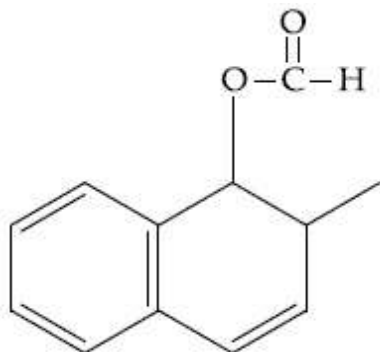

8643512578.

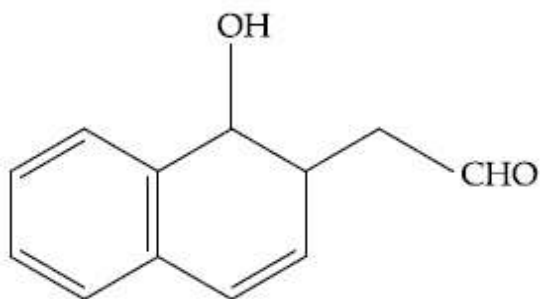

8643512579.

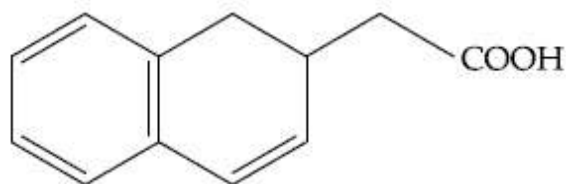

8643512580.

Question Number : 46 Question Id : 864351856 Question Type : MCQ Option Shuffling : Yes Is Question Mandatory : No

Correct Marks : 4 Wrong Marks : 1

Assertion A : Enol form of acetone [CH_3COCH_3] exists in $< 0.1\%$ quantity. However, the enol form of acetyl acetone [$\text{CH}_3\text{COCH}_2\text{OCCH}_3$] exists in approximately 15% quantity.

Reason R : Enol form of acetylacetone is stabilized by intramolecular hydrogen bonding, which is not possible in enol form of acetone.

Choose the correct statement :

Options :

8643512581. Both **A** and **R** are true and **R** is the correct explanation of **A**

8643512582. Both **A** and **R** are true but **R** is not the correct explanation of **A**

8643512583. **A** is true but **R** is false

8643512584. **A** is false but **R** is true

Question Number : 46 Question Id : 864351856 Question Type : MCQ Option Shuffling : Yes Is Question Mandatory : No

Correct Marks : 4 Wrong Marks : 1

કથન A : એસિટોન $[\text{CH}_3\text{COCH}_3]$ નું ઈનોલ સ્વરૂપ $< 0.1\%$ જથ્થામાં અસ્તિત્વ ધરાવે છે જ્યારે એસિટાઈલ એસિટોનનું $[\text{CH}_3\text{COCH}_2\text{OCCH}_3]$ ઈનોલ સ્વરૂપ આશરે 15% જથ્થામાં અસ્તિત્વ ધરાવે છે.

કારણ R : એસિટાઈલ એસિટોનનું ઈનોલ સ્વરૂપ આતઃઆણ્વીય હાઈડ્રોજન બંધન વડે સ્થિર છે કે જે એસિટોનનાં ઈનોલ સ્વરૂપમાં શક્ય નથી.

સાચું વિધાન પસંદ કરો.

Options :

8643512581. બંને A અને R સાચાં છે અને R એ A ની સાચી સમજૂતી છે.

8643512582. બંને A અને R સાચાં છે પણ R એ A ની સાચી સમજૂતી નથી.

8643512583. A સાચું છે પણ R ખોટું છે.

8643512584. A ખોટું છે પણ R સાચું છે.

Question Number : 47 Question Id : 864351857 Question Type : MCQ Option Shuffling : Yes Is Question Mandatory : No

Correct Marks : 4 Wrong Marks : 1

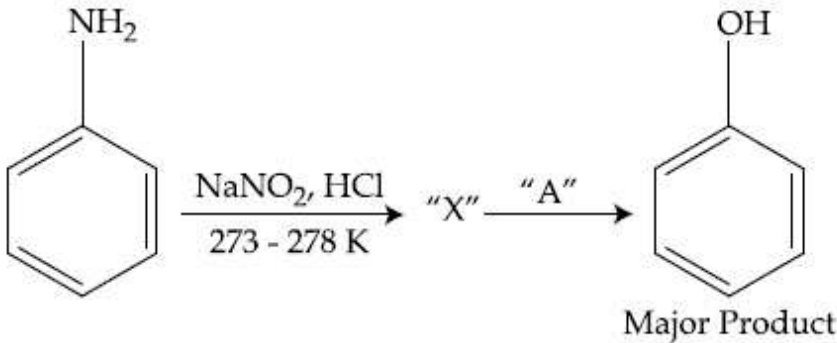

In the above chemical reaction, intermediate "X" and reagent/condition "A" are :

Options :

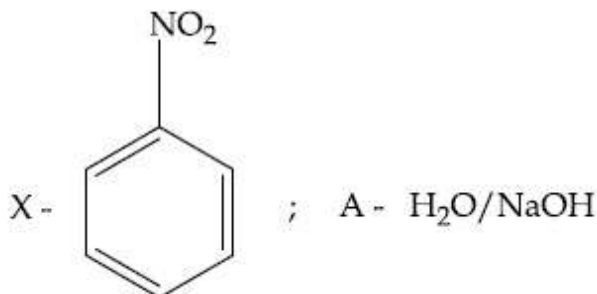

8643512585.

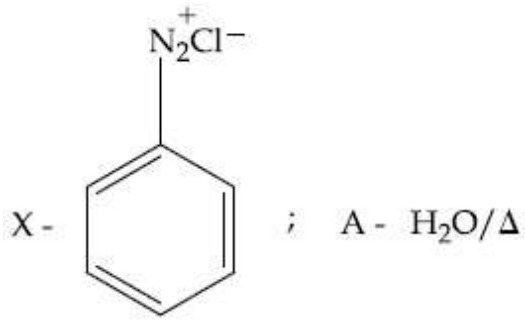

8643512586.

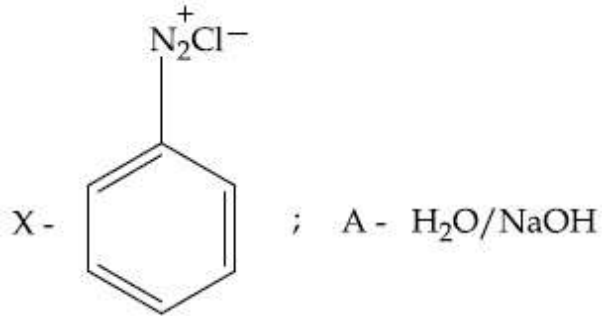

8643512587.

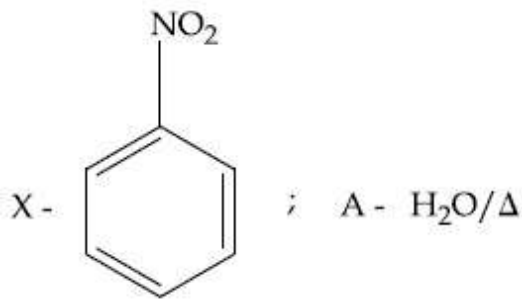

8643512588.

Question Number : 47 Question Id : 864351857 Question Type : MCQ Option Shuffling : Yes Is Question Mandatory : No

Correct Marks : 4 Wrong Marks : 1

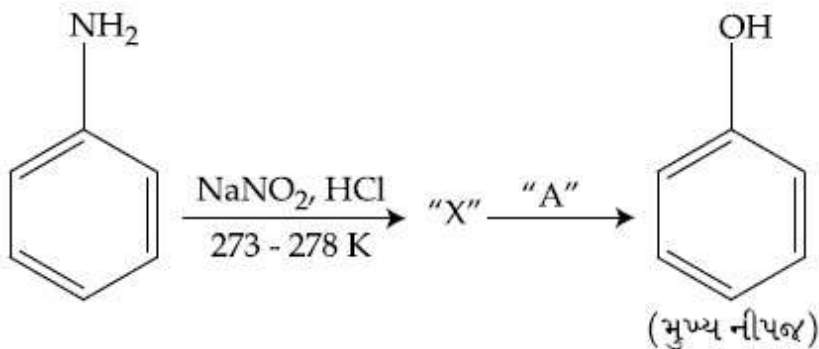

ઉપરની રાસાયણિક પ્રક્રિયામાં, મધ્યવર્તી "X" અને પ્રક્રિયક/પરિસ્થિતિ "A" શોધો.

Options :

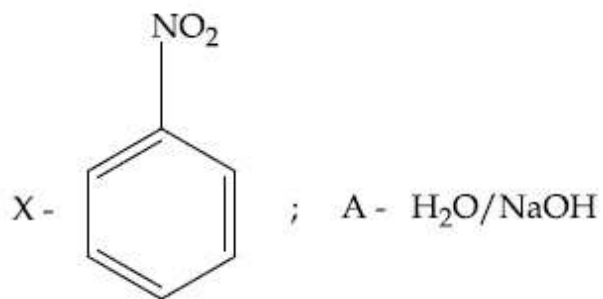

8643512585.

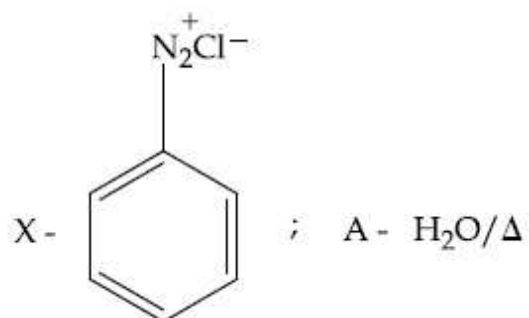

8643512586.

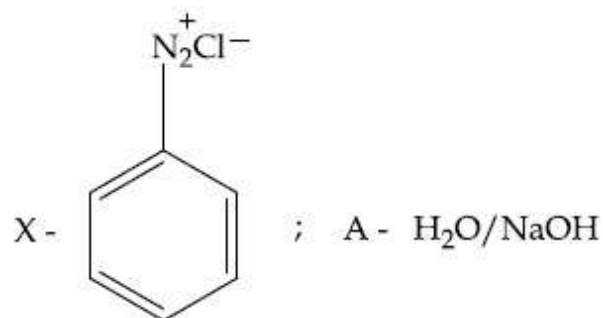

8643512587.

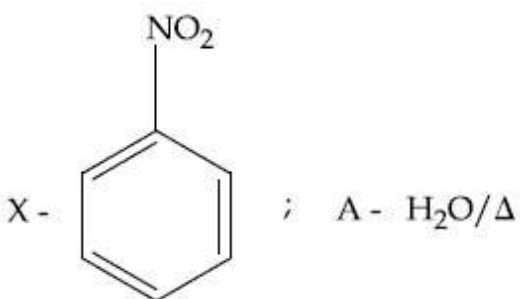

8643512588.

Question Number : 48 Question Id : 864351858 Question Type : MCQ Option Shuffling : Yes Is Question Mandatory : No Correct Marks : 4 Wrong Marks : 1

Which of the following reaction DOES NOT involve Hoffmann bromamide degradation ?

Options :

8643512589.

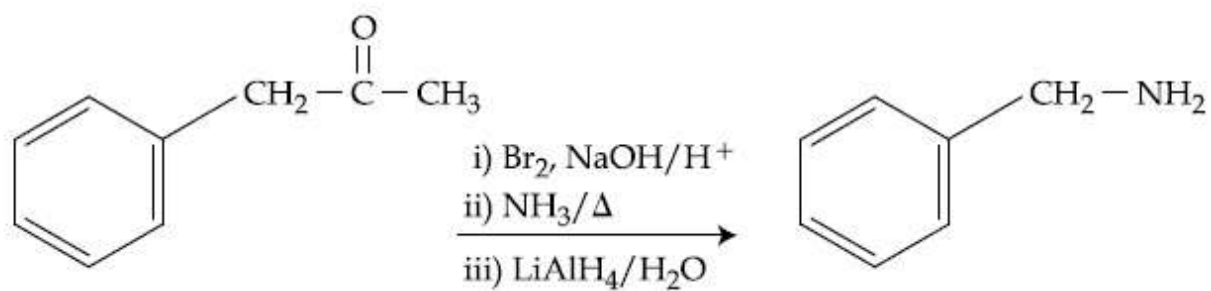

8643512590.

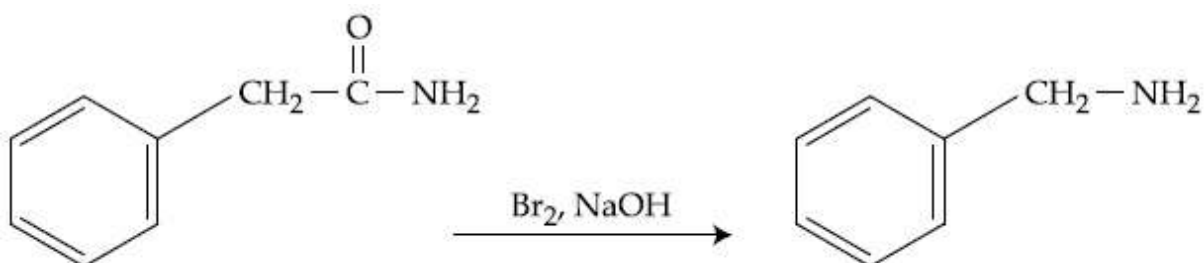

8643512591.

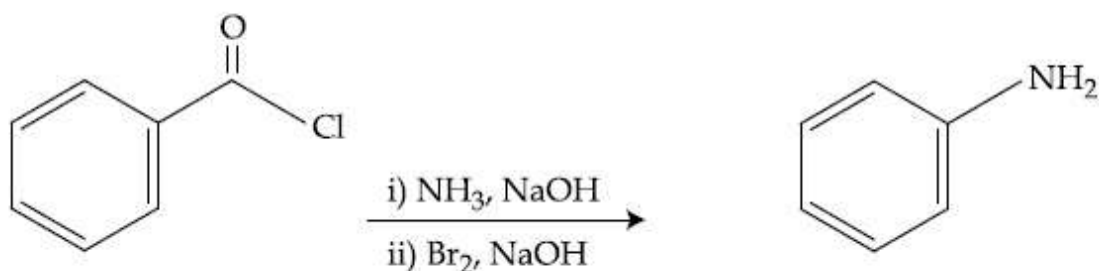

8643512592.

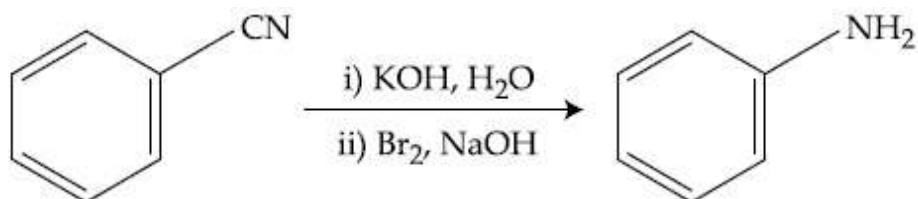

Question Number : 48 Question Id : 864351858 Question Type : MCQ Option Shuffling : Yes Is Question Mandatory : No

Correct Marks : 4 Wrong Marks : 1

नीचे आपेलामांथी कर्ण प्रक्रिया लोङ्गमान ओमेमार्ड डिग्रेडेशन साथे संकणायेल नथी ?

Options :

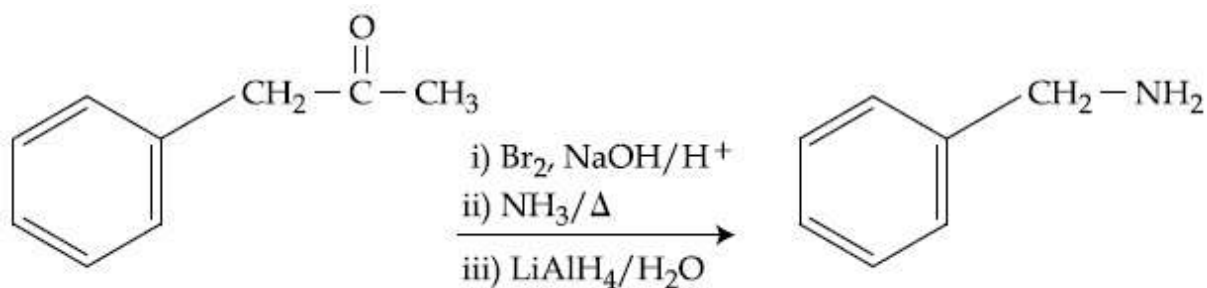

8643512589.

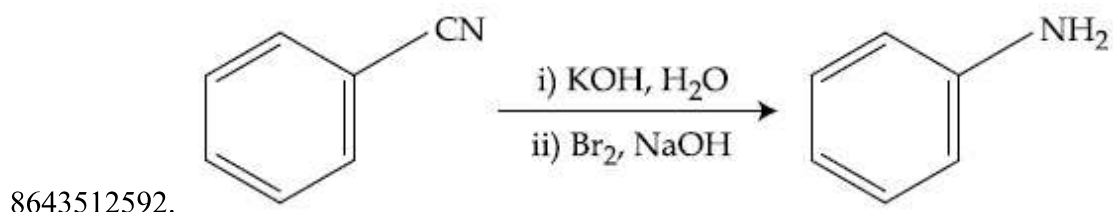
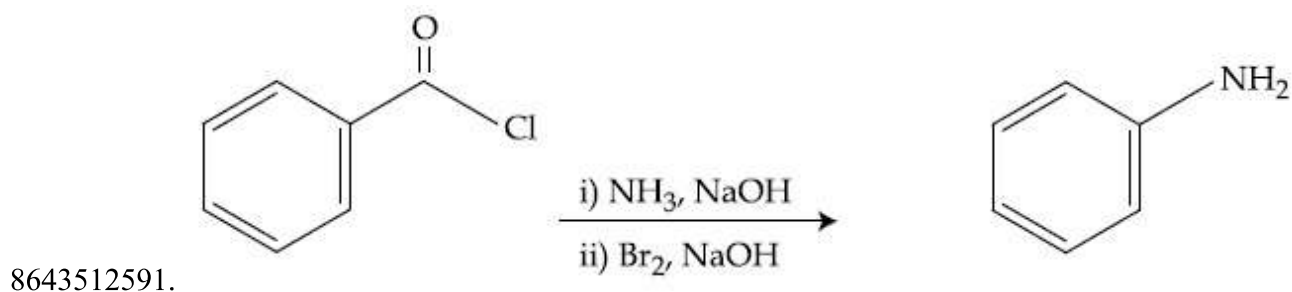
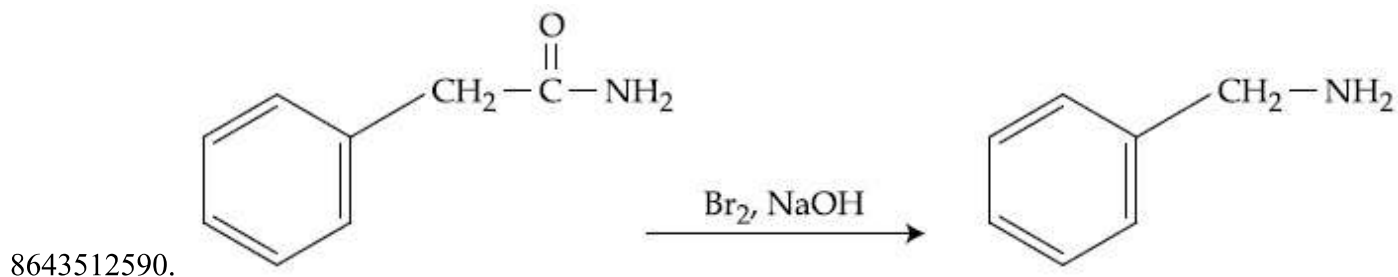

Question Number : 49 Question Id : 864351859 Question Type : MCQ Option Shuffling : Yes Is Question Mandatory : No

Correct Marks : 4 Wrong Marks : 1

The functions of antihistamine are :

Options :

8643512593. Antiallergic and Analgesic

8643512594. Analgesic and antacid

8643512595. Antacid and antiallergic

8643512596. Antiallergic and antidepressant

Question Number : 49 Question Id : 864351859 Question Type : MCQ Option Shuffling : Yes Is Question Mandatory : No

Correct Marks : 4 Wrong Marks : 1

प्रतिहिस्टैमार्शननुं कार्य (functions) शोधो :

Options :

8643512593. પ્રતિએલર્જ અને વેદનાહર
8643512594. વેદનાહર અને પ્રતિ એસિડ
8643512595. પ્રતિ એસિડ અને પ્રતિ એલર્જ
8643512596. પ્રતિએલર્જ અને ઉદાસીનતારોધી

Question Number : 50 Question Id : 864351860 Question Type : MCQ Option Shuffling : Yes Is Question Mandatory : No Correct Marks : 4 Wrong Marks : 1

Which among the following pairs of Vitamins is stored in our body relatively for longer duration ?

Options :

8643512597. Thiamine and Ascorbic acid
8643512598. Vitamin A and Vitamin D
8643512599. Thiamine and Vitamin A
8643512600. Ascorbic acid and Vitamin D

Question Number : 50 Question Id : 864351860 Question Type : MCQ Option Shuffling : Yes Is Question Mandatory : No Correct Marks : 4 Wrong Marks : 1

નીચે આપેલી વિટામીનોની જોડ પૈકી કઈ આપણા શરીરમાં લાંબા સમય માટે સચવાય (stored) છે ?

Options :

8643512597. થાયમીન અને એસ્કોર્બિક એસિડ
8643512598. વિટામીન A અને વિટામીન D
8643512599. થાયમીન અને વિટામીન A
8643512600. એસ્કોર્બિક એસિડ અને વિટામીન D

Chemistry Section B

Section Id :	86435158
Section Number :	4
Section type :	Online
Mandatory or Optional :	Mandatory
Number of Questions :	10
Number of Questions to be attempted :	5
Section Marks :	20
Mark As Answered Required? :	Yes
Sub-Section Number :	1
Sub-Section Id :	86435158
Question Shuffling Allowed :	Yes

Question Number : 51 Question Id : 864351861 Question Type : SA

Correct Marks : 4 Wrong Marks : 0

A 6.50 molal solution of KOH (aq.) has a density of 1.89 g cm^{-3} . The molarity of the solution is _____ mol dm^{-3} . (Round off to the Nearest Integer).

[Atomic masses : K : 39.0 u; O : 16.0 u; H : 1.0 u]

Response Type : Numeric

Evaluation Required For SA : Yes

Show Word Count : Yes

Answers Type : Equal

Text Areas : PlainText

Possible Answers :

100

Question Number : 51 Question Id : 864351861 Question Type : SA

Correct Marks : 4 Wrong Marks : 0

KOH (aq.) નું 6.50 મોલલ દ્રાવણ 1.89 g cm^{-3} ઘનતા ધરાવે છે. તો દ્રાવણની મોલારિટી _____ mol dm^{-3} છે. (નજીકનાં પૂર્ણાંકમાં રાઉન્ડ ઓફ કરો)

[પરમાણ્વીય દળો : K : 39.0 u; O : 16.0 u; H : 1.0 u]

Response Type : Numeric

Evaluation Required For SA : Yes

Show Word Count : Yes

Answers Type : Equal

Text Areas : PlainText

Possible Answers :

100

Question Number : 52 Question Id : 864351862 Question Type : SA

Correct Marks : 4 Wrong Marks : 0

A certain element crystallises in a bcc lattice of unit cell edge length 27\AA . If the same element under the same conditions crystallises in the fcc lattice, the edge length of the unit cell in \AA will be _____. (Round off to the Nearest Integer).

[Assume each lattice point has a single atom]

[Assume $\sqrt{3} = 1.73$, $\sqrt{2} = 1.41$]

Response Type : Numeric

Evaluation Required For SA : Yes

Show Word Count : Yes

Answers Type : Equal

Text Areas : PlainText

Possible Answers :

100

Question Number : 52 Question Id : 864351862 Question Type : SA

Correct Marks : 4 Wrong Marks : 0

એક નિશ્ચિત તત્વ એકમ કોષ ધાર લંબાઈ 27\AA સાથે bcc લેટાઈસમાં સ્ફટિકીકરણ પામે છે. તે જ તત્વ તે જ પરિસ્થિતિમાં fcc લેટાઈસમાં સ્ફટિકીકરણ પામે તો એકમ કોષની ધાર લંબાઈ \AA માં _____ થશે.

(નજીકનાં પૂર્ણાંકમાં રાઉન્ડ ઓફ કરો)

[ધારી લો કે દરેક લેટાઈસ બિંદુ એક જ પરમાણુ ધરાવે છે.]

[ધારી લો $\sqrt{3} = 1.73$, $\sqrt{2} = 1.41$]

Response Type : Numeric

Evaluation Required For SA : Yes

Show Word Count : Yes

Answers Type : Equal

Text Areas : PlainText

Possible Answers :

100

Question Number : 53 Question Id : 864351863 Question Type : SA

Correct Marks : 4 Wrong Marks : 0

When light of wavelength 248 nm falls on a metal of threshold energy 3.0 eV, the de-Broglie wavelength of emitted electrons is _____ Å. (Round off to the Nearest Integer).

[Use : $\sqrt{3} = 1.73$, $h = 6.63 \times 10^{-34}$ Js

$m_e = 9.1 \times 10^{-31}$ kg ; $c = 3.0 \times 10^8$ ms⁻¹ ; $1\text{eV} = 1.6 \times 10^{-19}$ J]

Response Type : Numeric

Evaluation Required For SA : Yes

Show Word Count : Yes

Answers Type : Equal

Text Areas : PlainText

Possible Answers :

100

Question Number : 53 **Question Id :** 864351863 **Question Type :** SA

Correct Marks : 4 **Wrong Marks :** 0

3.0 eV દેહલી ઊર્જા વાળી ધાતુ ઉપર 248 nm તરંગલંબાઈ વાળો પ્રકાશ આપાત (falls) કરવામાં આવે ત્યારે, ઉત્સર્જિત ઈલેક્ટ્રોનોની ડી-બ્રોગલી તરંગલંબાઈ _____ Å છે. (નજીકનાં પૂર્ણાંકમાં રાઉન્ડ ઓફ કરો)

[ઉપયોગ કરો : $\sqrt{3} = 1.73$, $h = 6.63 \times 10^{-34}$ Js

$m_e = 9.1 \times 10^{-31}$ kg ; $c = 3.0 \times 10^8$ ms⁻¹ ; $1\text{eV} = 1.6 \times 10^{-19}$ J]

Response Type : Numeric

Evaluation Required For SA : Yes

Show Word Count : Yes

Answers Type : Equal

Text Areas : PlainText

Possible Answers :

100

Question Number : 54 **Question Id :** 864351864 **Question Type :** SA

Correct Marks : 4 **Wrong Marks :** 0

For the reaction $A(g) \rightleftharpoons B(g)$ at 495 K, $\Delta_r G^\circ = -9.478$ kJ mol⁻¹.

If we start the reaction in a closed container at 495 K with 22 millimoles of A, the amount of B in the equilibrium mixture is _____ millimoles. (Round off to the Nearest Integer).

[$R = 8.314$ J mol⁻¹ K⁻¹ ; $\ln 10 = 2.303$]

Response Type : Numeric

Evaluation Required For SA : Yes

Show Word Count : Yes

Answers Type : Equal

Text Areas : PlainText

Possible Answers :

Question Number : 54 Question Id : 864351864 Question Type : SA

Correct Marks : 4 Wrong Marks : 0

$A(g) \rightleftharpoons B(g)$ પ્રક્રિયા માટે, 495 K પર, $\Delta_r G^\circ = -9.478 \text{ kJ mol}^{-1}$.

495 K પર A નાં 22 millimoles સાથે એક બંધ પાત્રમાં પ્રક્રિયાની શરૂઆત કરવામાં આવે છે. તો સંતુલને મિશ્રણમાં B નો જથ્થો _____ millimoles થશે. (નજીકનાં પૂર્ણાંકમાં રાઉન્ડ ઓફ કરો)

[$R = 8.314 \text{ J mol}^{-1} \text{ K}^{-1}$; $\ln 10 = 2.303$]

Response Type : Numeric

Evaluation Required For SA : Yes

Show Word Count : Yes

Answers Type : Equal

Text Areas : PlainText

Possible Answers :

100

Question Number : 55 Question Id : 864351865 Question Type : SA

Correct Marks : 4 Wrong Marks : 0

AB_2 is 10% dissociated in water to A^{2+} and B^- . The boiling point of a 10.0 molal aqueous solution of AB_2 is _____ $^\circ\text{C}$. (Round off to the Nearest Integer).

[Given : Molal elevation constant of water $K_b = 0.5 \text{ K kg mol}^{-1}$ boiling point of pure water = 100°C]

Response Type : Numeric

Evaluation Required For SA : Yes

Show Word Count : Yes

Answers Type : Equal

Text Areas : PlainText

Possible Answers :

100

Question Number : 55 Question Id : 864351865 Question Type : SA

Correct Marks : 4 Wrong Marks : 0

AB_2 નાં 10% પાણીમાં A^{2+} અને B^- માં વિયોજીત થાય છે. તો AB_2 નાં 10.0 મોલલ જલીય દ્રાવણનું ઉત્કલનબિંદુ _____ $^\circ\text{C}$ છે. (નજીકનાં પૂર્ણાંકમાં રાઉન્ડ ઓફ કરો)

[આપેલ : પાણીનો મોલલ ઉન્નયન અચળાંક $K_b = 0.5 \text{ K kg mol}^{-1}$ અને શુદ્ધ પાણીનું ઉત્કલન બિંદુ = 100°C]

Response Type : Numeric

Evaluation Required For SA : Yes

Show Word Count : Yes

Answers Type : Equal

Text Areas : PlainText

Possible Answers :

100

Question Number : 56 Question Id : 864351866 Question Type : SA

Correct Marks : 4 Wrong Marks : 0

Two salts A_2X and MX have the same value of solubility product of 4.0×10^{-12} . The ratio of

their molar solubilities i.e. $\frac{S(A_2X)}{S(MX)} = \text{_____}$. (Round off to the Nearest Integer).

Response Type : Numeric

Evaluation Required For SA : Yes

Show Word Count : Yes

Answers Type : Equal

Text Areas : PlainText

Possible Answers :

100

Question Number : 56 Question Id : 864351866 Question Type : SA

Correct Marks : 4 Wrong Marks : 0

A_2X અને MX બે ક્ષારો 4.0×10^{-12} દ્રાવ્યતા ગુણકારનું સમાન મૂલ્ય ધરાવે છે. તેમની મોલર દ્રાવ્યતાઓનો ગુણોત્તર

$\frac{S(A_2X)}{S(MX)} = \text{_____}$ છે. (નજીકનાં પૂર્ણાંકમાં રાઉન્ડ ઓફ કરો)

Response Type : Numeric

Evaluation Required For SA : Yes

Show Word Count : Yes

Answers Type : Equal

Text Areas : PlainText

Possible Answers :

100

Question Number : 57 Question Id : 864351867 Question Type : SA

Correct Marks : 4 Wrong Marks : 0

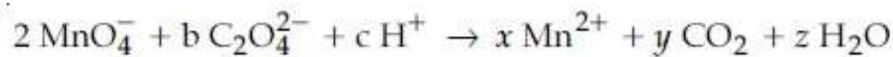

If the above equation is balanced with integer coefficients, the value of c is _____.
(Round off to the Nearest Integer).

Response Type : Numeric

Evaluation Required For SA : Yes

Show Word Count : Yes

Answers Type : Equal

Text Areas : PlainText

Possible Answers :

100

Question Number : 57 Question Id : 864351867 Question Type : SA

Correct Marks : 4 Wrong Marks : 0

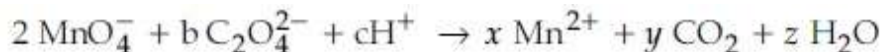

પૂર્ણાંક સહગુણકો સાથે ઉપરની પ્રક્રિયાને સંતુલિત કરવામાં આવે તો c નું મૂલ્ય _____ છે.

(નજીકનાં પૂર્ણાંકમાં રાઉન્ડ ઓફ કરો)

Response Type : Numeric

Evaluation Required For SA : Yes

Show Word Count : Yes

Answers Type : Equal

Text Areas : PlainText

Possible Answers :

100

Question Number : 58 Question Id : 864351868 Question Type : SA

Correct Marks : 4 Wrong Marks : 0

The decomposition of formic acid on gold surface follows first order kinetics. If the rate constant at 300 K is $1.0 \times 10^{-3} \text{ s}^{-1}$ and the activation energy $E_a = 11.488 \text{ kJ mol}^{-1}$, the rate constant at 200 K is _____ $\times 10^{-5} \text{ s}^{-1}$. (Round off to the Nearest Integer).

(Given : $R = 8.314 \text{ J mol}^{-1} \text{ K}^{-1}$)

Response Type : Numeric

Evaluation Required For SA : Yes

Show Word Count : Yes

Answers Type : Equal

Text Areas : PlainText

Possible Answers :

100

Question Number : 58 Question Id : 864351868 Question Type : SA

Correct Marks : 4 Wrong Marks : 0

સોનાની સપાટી પર ફોર્મિક એસિડનું વિઘટન એ પ્રથમ ક્રમ ગતિકીને અનુસરે છે. જો 300 K પર વેગ અચળાંક $1.0 \times 10^{-3} \text{ s}^{-1}$ અને સક્રિયકરણ શક્તિ $E_a = 11.488 \text{ kJ mol}^{-1}$ હોય તો, 200 K પર વેગ અચળાંક _____ $\times 10^{-5} \text{ s}^{-1}$ થાય. (નજીકનાં પૂર્ણાંકમાં રાઉન્ડ ઓફ કરો)

(આપેલ : $R = 8.314 \text{ J mol}^{-1} \text{ K}^{-1}$)

Response Type : Numeric

Evaluation Required For SA : Yes

Show Word Count : Yes

Answers Type : Equal

Text Areas : PlainText

Possible Answers :

100

Question Number : 59 **Question Id :** 864351869 **Question Type :** SA

Correct Marks : 4 **Wrong Marks :** 0

The equivalents of ethylene diamine required to replace the neutral ligands from the coordination sphere of the trans-complex of $\text{CoCl}_3 \cdot 4\text{NH}_3$ is _____. (Round off to the Nearest Integer).

Response Type : Numeric

Evaluation Required For SA : Yes

Show Word Count : Yes

Answers Type : Equal

Text Areas : PlainText

Possible Answers :

100

Question Number : 59 **Question Id :** 864351869 **Question Type :** SA

Correct Marks : 4 **Wrong Marks :** 0

$\text{CoCl}_3 \cdot 4\text{NH}_3$ નાં ટ્રાન્સ-સંકિર્ણનાં સર્વા પ્રભાવ ક્ષેત્ર (coordination sphere) માંથી તટસ્થ લિગાન્ડ્સને બદલવા માટે ઈથીલીન ડાયએમાઈનનાં જરૂરી સમતુલ્યો _____ છે. (નજીકનાં પૂર્ણાંકમાં રાઉન્ડ ઓફ કરો)

Response Type : Numeric

Evaluation Required For SA : Yes

Show Word Count : Yes

Answers Type : Equal

Text Areas : PlainText

Possible Answers :

100

Question Number : 60 **Question Id :** 864351870 **Question Type :** SA

Correct Marks : 4 **Wrong Marks :** 0

Complete combustion of 750 g of an organic compound provides 420 g of CO₂ and 210 g of H₂O. The percentage composition of carbon and hydrogen in organic compound is 15.3 and _____ respectively. (Round off to the Nearest Integer).

Response Type : Numeric

Evaluation Required For SA : Yes

Show Word Count : Yes

Answers Type : Equal

Text Areas : PlainText

Possible Answers :

100

Question Number : 60 **Question Id :** 864351870 **Question Type :** SA

Correct Marks : 4 **Wrong Marks :** 0

750 g એક કાર્બનિક સંયોજનનું સંપૂર્ણ દહન કરતાં તે CO₂ નાં 420 g અને H₂O નાં 210 g આપે છે. કાર્બનિક સંયોજનમાં કાર્બન અને હાઈડ્રોજનની ટકાવારી 15.3 અને અનુક્રમે _____ છે.

(નજીકનાં પૂર્ણાંકમાં રાઉન્ડ ઓફ કરો)

Response Type : Numeric

Evaluation Required For SA : Yes

Show Word Count : Yes

Answers Type : Equal

Text Areas : PlainText

Possible Answers :

100

Mathematics Section A

Section Id :	86435159
Section Number :	5
Section type :	Online
Mandatory or Optional :	Mandatory
Number of Questions :	20
Number of Questions to be attempted :	20
Section Marks :	80
Mark As Answered Required? :	Yes
Sub-Section Number :	1
Sub-Section Id :	86435159
Question Shuffling Allowed :	Yes

Question Number : 61 **Question Id :** 864351871 **Question Type :** MCQ **Option Shuffling :** Yes **Is**

Question Mandatory : No

Correct Marks : 4 **Wrong Marks :** 1

Let $A = \begin{bmatrix} i & -i \\ -i & i \end{bmatrix}$, $i = \sqrt{-1}$. Then, the system of linear equations $A \begin{bmatrix} x \\ y \end{bmatrix} = \begin{bmatrix} 8 \\ 64 \end{bmatrix}$ has :

Options :

8643512611. No solution

8643512612. A unique solution

8643512613. Infinitely many solutions

8643512614. Exactly two solutions

Question Number : 61 Question Id : 864351871 Question Type : MCQ Option Shuffling : Yes Is Question Mandatory : No

Correct Marks : 4 Wrong Marks : 1

ધારો કે $A = \begin{bmatrix} i & -i \\ -i & i \end{bmatrix}$, $i = \sqrt{-1}$. તો સુરેખ સમીકરણ સંહિત $A \begin{bmatrix} x \\ y \end{bmatrix} = \begin{bmatrix} 8 \\ 64 \end{bmatrix}$ ને _____.

Options :

8643512611. ઉકેલ નથી

8643512612. અનન્ય ઉકેલ છે

8643512613. અસંખ્ય ઉકેલો છે

8643512614. બરાબર બે ઉકેલો છે

Question Number : 62 Question Id : 864351872 Question Type : MCQ Option Shuffling : Yes Is Question Mandatory : No

Correct Marks : 4 Wrong Marks : 1

Let the functions $f: \mathbb{R} \rightarrow \mathbb{R}$ and $g: \mathbb{R} \rightarrow \mathbb{R}$ be defined as :

$$f(x) = \begin{cases} x + 2, & x < 0 \\ x^2, & x \geq 0 \end{cases} \text{ and } g(x) = \begin{cases} x^3, & x < 1 \\ 3x - 2, & x \geq 1 \end{cases}$$

Then, the number of points in \mathbb{R} where $(f \circ g)(x)$ is NOT differentiable is equal to :

Options :

8643512615. 0

8643512616. 1

8643512617. 2

8643512618. 3

Question Number : 62 Question Id : 864351872 Question Type : MCQ Option Shuffling : Yes Is Question Mandatory : No

Correct Marks : 4 Wrong Marks : 1

ધારો કે વિધેયો $f: \mathbb{R} \rightarrow \mathbb{R}$ અને $g: \mathbb{R} \rightarrow \mathbb{R}$ એ

$$f(x) = \begin{cases} x + 2, & x < 0 \\ x^2, & x \geq 0 \end{cases} \text{ અને } g(x) = \begin{cases} x^3, & x < 1 \\ 3x - 2, & x \geq 1 \end{cases}$$

મુજબ વ્યાખ્યાયિત છે. તો જ્યાં $(f \circ g)(x)$ વિકલનીય ન હોય તેવા \mathbb{R} નાં બિંદુઓની સંખ્યા _____ છે.

Options :

8643512615. 0

8643512616. 1

8643512617. 2

8643512618. 3

Question Number : 63 Question Id : 864351873 Question Type : MCQ Option Shuffling : Yes Is Question Mandatory : No

Correct Marks : 4 Wrong Marks : 1

Let P be a plane $lx + my + nz = 0$ containing the line, $\frac{1-x}{1} = \frac{y+4}{2} = \frac{z+2}{3}$. If plane P divides the line segment AB joining points A(-3, -6, 1) and B(2, 4, -3) in ratio k : 1 then the value of k is equal to :

Options :

8643512619. 2

8643512620. 1.5

8643512621. 3

8643512622. 4

Question Number : 63 Question Id : 864351873 Question Type : MCQ Option Shuffling : Yes Is Question Mandatory : No

Correct Marks : 4 Wrong Marks : 1

ધારો કે રેખા $\frac{1-x}{1} = \frac{y+4}{2} = \frac{z+2}{3}$ ને સમાવતુ સમતલ P એ $lx + my + nz = 0$ છે. જો સમતલ P એ બિંદુઓ $A(-3, -6, 1)$ અને $B(2, 4, -3)$ ને જોડતી રેખાખંડ AB નું $k : 1$ નાં ગુણોત્તરમાં વિભાજન કરે, તો k નું મૂલ્ય _____ થાય.

Options :

8643512619. 2

8643512620. 1.5

8643512621. 3

8643512622. 4

Question Number : 64 Question Id : 864351874 Question Type : MCQ Option Shuffling : Yes Is Question Mandatory : No

Correct Marks : 4 Wrong Marks : 1

If for $a > 0$, the feet of perpendiculars from the points $A(a, -2a, 3)$ and $B(0, 4, 5)$ on the plane $lx + my + nz = 0$ are points $C(0, -a, -1)$ and D respectively, then the length of line segment CD is equal to :

Options :

8643512623. $\sqrt{31}$

8643512624. $\sqrt{66}$

8643512625. $\sqrt{41}$

8643512626. $\sqrt{55}$

Question Number : 64 Question Id : 864351874 Question Type : MCQ Option Shuffling : Yes Is Question Mandatory : No

Correct Marks : 4 Wrong Marks : 1

$a > 0$ માટે બે બિંદુઓ $A(a, -2a, 3)$ અને $B(0, 4, 5)$ થી સમતલ $lx + my + nz = 0$ પરનાં લંબપાદો અનુક્રમે બિંદુઓ $C(0, -a, -1)$ અને D હોય, તો રેખાખંડ CD ની લંબાઈ _____ છે.

Options :

8643512623. $\sqrt{31}$

8643512624. $\sqrt{66}$

8643512625. $\sqrt{41}$

8643512626. $\sqrt{55}$

Question Number : 65 Question Id : 864351875 Question Type : MCQ Option Shuffling : Yes Is Question Mandatory : No

Correct Marks : 4 Wrong Marks : 1

Consider three observations a , b and c such that $b = a + c$. If the standard deviation of $a + 2$, $b + 2$, $c + 2$ is d , then which of the following is true ?

Options :

8643512627. $b^2 = 3(a^2 + c^2) - 9d^2$

8643512628. $b^2 = 3(a^2 + c^2) + 9d^2$

8643512629. $b^2 = a^2 + c^2 + 3d^2$

8643512630. $b^2 = 3(a^2 + c^2 + d^2)$

Question Number : 65 Question Id : 864351875 Question Type : MCQ Option Shuffling : Yes Is Question Mandatory : No

Correct Marks : 4 Wrong Marks : 1

ધારો કે ત્રણ અવલોકનો a , b અને c માટે $b = a + c$. જો $a + 2$, $b + 2$, $c + 2$ નું પ્રમાણિત વિચલન d હોય તો, નીચેના માંથી કયું સાચું છે ?

Options :

8643512627. $b^2 = 3(a^2 + c^2) - 9d^2$

8643512628. $b^2 = 3(a^2 + c^2) + 9d^2$

8643512629. $b^2 = a^2 + c^2 + 3d^2$

8643512630. $b^2 = 3(a^2 + c^2 + d^2)$

Question Number : 66 Question Id : 864351876 Question Type : MCQ Option Shuffling : Yes Is Question Mandatory : No Correct Marks : 4 Wrong Marks : 1

Let the position vectors of two points P and Q be $3\hat{i} - \hat{j} + 2\hat{k}$ and $\hat{i} + 2\hat{j} - 4\hat{k}$, respectively. Let R and S be two points such that the direction ratios of lines PR and QS are $(4, -1, 2)$ and $(-2, 1, -2)$, respectively. Let lines PR and QS intersect at T. If the vector \vec{TA} is perpendicular to both \vec{PR} and \vec{QS} and the length of vector \vec{TA} is $\sqrt{5}$ units, then the modulus of a position vector of A is :

Options :

8643512631. $\sqrt{5}$

8643512632. $\sqrt{171}$

8643512633. $\sqrt{227}$

8643512634. $\sqrt{482}$

Question Number : 66 Question Id : 864351876 Question Type : MCQ Option Shuffling : Yes Is Question Mandatory : No Correct Marks : 4 Wrong Marks : 1

ધારો કે બે બિંદુઓ P અને Q નાં સ્થાન સદિશો અનુક્રમે $3\hat{i} - \hat{j} + 2\hat{k}$ અને $\hat{i} + 2\hat{j} - 4\hat{k}$ છે. ધારો કે, R અને S બે એવા બિંદુઓ છે કે જેથી રેખાઓ PR અને QS નાં દિક્ગુણોત્તર અનુક્રમે $(4, -1, 2)$ અને $(-2, 1, -2)$ છે. ધારો કે રેખાઓ PR અને QS એ T પાસે છેદે છે. જો સદિશ \vec{TA} એ \vec{PR} અને \vec{QS} બંનેને લંબ હોય તથા સદિશ \vec{TA} ની લંબાઈ $\sqrt{5}$ એકમ હોય, તો A નાં સ્થાન સદિશનો માનાંક _____ છે.

Options :

8643512631. $\sqrt{5}$

8643512632. $\sqrt{171}$

8643512633. $\sqrt{227}$

8643512634. $\sqrt{482}$

Question Number : 67 Question Id : 864351877 Question Type : MCQ Option Shuffling : Yes Is Question Mandatory : No

Correct Marks : 4 Wrong Marks : 1

Let a vector $\alpha\hat{i} + \beta\hat{j}$ be obtained by rotating the vector $\sqrt{3}\hat{i} + \hat{j}$ by an angle 45° about the origin in counterclockwise direction in the first quadrant. Then the area of triangle having vertices (α, β) , $(0, \beta)$ and $(0, 0)$ is equal to :

Options :

8643512635. $\frac{1}{2}$

8643512636. 1

8643512637. $2\sqrt{2}$

8643512638. $\frac{1}{\sqrt{2}}$

Question Number : 67 Question Id : 864351877 Question Type : MCQ Option Shuffling : Yes Is

Question Mandatory : No

Correct Marks : 4 Wrong Marks : 1

ધારો કે સદિશ $\sqrt{3}\hat{i} + \hat{j}$ ને પ્રથમ અરણમાં ઊગમબિંદુની ફરતે ઘડિયાલનાં કાંટાની વિરુદ્ધ દિશામાં 45° ના ખૂણા જેટલું

પરિભ્રમણ કરાવતા મળતો સદિશ $\alpha\hat{i} + \beta\hat{j}$ છે. તો (α, β) , $(0, \beta)$ અને $(0, 0)$ શિરોબિંદુઓ વાળા ત્રિકોણનું ક્ષેત્રફળ

_____ છે.

Options :

8643512635. $\frac{1}{2}$

8643512636. 1

8643512637. $2\sqrt{2}$

8643512638. $\frac{1}{\sqrt{2}}$

Question Number : 68 Question Id : 864351878 Question Type : MCQ Option Shuffling : Yes Is

Question Mandatory : No

Correct Marks : 4 Wrong Marks : 1

The number of roots of the equation,

$$(81)^{\sin^2 x} + (81)^{\cos^2 x} = 30$$

in the interval $[0, \pi]$ is equal to :

Options :

8643512639. 2

8643512640. 3

8643512641. 4

8643512642. 8

Question Number : 68 Question Id : 864351878 Question Type : MCQ Option Shuffling : Yes Is

Question Mandatory : No

Correct Marks : 4 Wrong Marks : 1

$[0, \pi]$ અંતરાલમાં સમીકરણ $(81)^{\sin^2 x} + (81)^{\cos^2 x} = 30$ ની બીજેની સંખ્યા _____ છે.

Options :

8643512639. 2

8643512640. 3

8643512641. 4

8643512642. 8

Question Number : 69 Question Id : 864351879 Question Type : MCQ Option Shuffling : Yes Is Question Mandatory : No

Correct Marks : 4 Wrong Marks : 1

A pack of cards has one card missing. Two cards are drawn randomly and are found to be spades. The probability that the missing card is not a spade, is :

Options :

8643512643. $\frac{22}{425}$

8643512644. $\frac{52}{867}$

8643512645. $\frac{39}{50}$

8643512646. $\frac{3}{4}$

Question Number : 69 Question Id : 864351879 Question Type : MCQ Option Shuffling : Yes Is Question Mandatory : No

Correct Marks : 4 Wrong Marks : 1

પત્તાની બેડમાંથી એક પત્તુ ખોવાયેલ છે. આ બેડમાંથી બે પત્તા યાદચ્છિક રીતે ખેંચવામાં આવે છે અને તે કાળીના પત્તા હોવાનું માલૂમ પડે છે. તો ખોવાયેલ પત્તુ કાળીનું પત્તુ ન હોવાની સંભાવના _____ છે.

Options :

8643512643. $\frac{22}{425}$

8643512644. $\frac{52}{867}$

8643512645. $\frac{39}{50}$

8643512646. $\frac{3}{4}$

Question Number : 70 Question Id : 864351880 Question Type : MCQ Option Shuffling : Yes Is Question Mandatory : No

Correct Marks : 4 Wrong Marks : 1

The range of $a \in \mathbb{R}$ for which the function

$$f(x) = (4a - 3)(x + \log_e 5) + 2(a - 7) \cot\left(\frac{x}{2}\right) \sin^2\left(\frac{x}{2}\right), \quad x \neq 2n\pi, n \in \mathbb{N}$$

is :

Options :

8643512647. $[1, \infty)$

8643512648. $(-\infty, -1]$

8643512649. $\left[-\frac{4}{3}, 2\right]$

8643512650. $(-3, 1)$

Question Number : 70 Question Id : 864351880 Question Type : MCQ Option Shuffling : Yes Is Question Mandatory : No

Correct Marks : 4 Wrong Marks : 1

વિધેય $f(x) = (4a - 3)(x + \log_e 5) + 2(a - 7) \cot\left(\frac{x}{2}\right) \sin^2\left(\frac{x}{2}\right), \quad x \neq 2n\pi, n \in \mathbb{N}$ ને ક્રિતિકબિંદુઓ

(Critical points) હોય તેવા $a \in \mathbb{R}$ નો વિસ્તાર _____ છે.

Options :

8643512647. $[1, \infty)$

8643512648. $(-\infty, -1]$

8643512649. $\left[-\frac{4}{3}, 2\right]$

8643512650. $(-3, 1)$

Question Number : 71 Question Id : 864351881 Question Type : MCQ Option Shuffling : Yes Is Question Mandatory : No Correct Marks : 4 Wrong Marks : 1

If n is the number of irrational terms in the expansion of $(3^{1/4} + 5^{1/8})^{60}$, then $(n - 1)$ is divisible by :

Options :

8643512651. 30

8643512652. 8

8643512653. 26

8643512654. 7

Question Number : 71 Question Id : 864351881 Question Type : MCQ Option Shuffling : Yes Is Question Mandatory : No Correct Marks : 4 Wrong Marks : 1

$(3^{1/4} + 5^{1/8})^{60}$ નાં વિસ્તરણમાં અસંમેય પદોની સંખ્યા જો n હોય, તો $(n - 1)$ એ _____ વડે ભાજ્ય છે.

Options :

8643512651. 30

8643512652. 8

8643512653. 26

8643512654. 7

Question Number : 72 Question Id : 864351882 Question Type : MCQ Option Shuffling : Yes Is Question Mandatory : No

Correct Marks : 4 Wrong Marks : 1

Let $[x]$ denote greatest integer less than or equal to x . If for $n \in \mathbb{N}$,

$$(1 - x + x^3)^n = \sum_{j=0}^{3n} a_j x^j, \text{ then}$$

$$\sum_{j=0}^{\left[\frac{3n}{2}\right]} a_{2j} + 4 \sum_{j=0}^{\left[\frac{3n-1}{2}\right]} a_{2j+1} \text{ is equal to :}$$

Options :

8643512655. 2^{n-1}

8643512656. n

8643512657. 2

8643512658. 1

Question Number : 72 Question Id : 864351882 Question Type : MCQ Option Shuffling : Yes Is Question Mandatory : No

Correct Marks : 4 Wrong Marks : 1

ધારો કે $[x]$ એ x અથવા x થી નાનો મહત્તમ પૂર્ણાંક દર્શાવે છે. $n \in \mathbb{N}$ માટે, જો

$$(1 - x + x^3)^n = \sum_{j=0}^{3n} a_j x^j, \text{ તો}$$

$$\sum_{j=0}^{\left[\frac{3n}{2}\right]} a_{2j} + 4 \sum_{j=0}^{\left[\frac{3n-1}{2}\right]} a_{2j+1} = \underline{\hspace{2cm}}.$$

Options :

8643512655. 2^{n-1}

8643512656. n

8643512657. 2

8643512658. 1

Question Number : 73 Question Id : 864351883 Question Type : MCQ Option Shuffling : Yes Is Question Mandatory : No

Correct Marks : 4 Wrong Marks : 1

Which of the following Boolean expression is a tautology ?

Options :

8643512659. $(p \wedge q) \vee (p \vee q)$

8643512660. $(p \wedge q) \vee (p \rightarrow q)$

8643512661. $(p \wedge q) \wedge (p \rightarrow q)$

8643512662. $(p \wedge q) \rightarrow (p \rightarrow q)$

Question Number : 73 Question Id : 864351883 Question Type : MCQ Option Shuffling : Yes Is Question Mandatory : No

Correct Marks : 4 Wrong Marks : 1

નીચેનામાંથી કઈ બૂલીય અભિવ્યક્તિ નિત્યસત્ય છે ?

Options :

8643512659. $(p \wedge q) \vee (p \vee q)$

8643512660. $(p \wedge q) \vee (p \rightarrow q)$

8643512661. $(p \wedge q) \wedge (p \rightarrow q)$

8643512662. $(p \wedge q) \rightarrow (p \rightarrow q)$

Question Number : 74 Question Id : 864351884 Question Type : MCQ Option Shuffling : Yes Is

Question Mandatory : No

Correct Marks : 4 Wrong Marks : 1

Let $S_k = \sum_{r=1}^k \tan^{-1} \left(\frac{6^r}{2^{2r+1} + 3^{2r+1}} \right)$. Then $\lim_{k \rightarrow \infty} S_k$ is equal to :

Options :

8643512663. $\frac{\pi}{2}$

8643512664. $\cot^{-1} \left(\frac{3}{2} \right)$

8643512665. $\tan^{-1} \left(\frac{3}{2} \right)$

8643512666. $\tan^{-1} (3)$

Question Number : 74 Question Id : 864351884 Question Type : MCQ Option Shuffling : Yes Is Question Mandatory : No

Correct Marks : 4 Wrong Marks : 1

ધારો કે $S_k = \sum_{r=1}^k \tan^{-1} \left(\frac{6^r}{2^{2r+1} + 3^{2r+1}} \right)$. તો $\lim_{k \rightarrow \infty} S_k =$ _____

Options :

8643512663. $\frac{\pi}{2}$

8643512664. $\cot^{-1} \left(\frac{3}{2} \right)$

8643512665. $\tan^{-1} \left(\frac{3}{2} \right)$

8643512666. $\tan^{-1} (3)$

Question Number : 75 Question Id : 864351885 Question Type : MCQ Option Shuffling : Yes Is Question Mandatory : No

Correct Marks : 4 Wrong Marks : 1

The number of elements in the set $\{x \in \mathbb{R} : (|x| - 3) |x + 4| = 6\}$ is equal to :

Options :

8643512667. 1

8643512668. 2

8643512669. 3

8643512670. 4

Question Number : 75 Question Id : 864351885 Question Type : MCQ Option Shuffling : Yes Is Question Mandatory : No

Correct Marks : 4 Wrong Marks : 1

ગણ $\{x \in \mathbb{R} : (|x| - 3) |x + 4| = 6\}$ નાં ઘટકોની સંખ્યા _____ છે.

Options :

8643512667. 1

8643512668. 2

8643512669. 3

8643512670. 4

Question Number : 76 Question Id : 864351886 Question Type : MCQ Option Shuffling : Yes Is Question Mandatory : No

Correct Marks : 4 Wrong Marks : 1

If for $x \in \left(0, \frac{\pi}{2}\right)$, $\log_{10} \sin x + \log_{10} \cos x = -1$ and $\log_{10}(\sin x + \cos x) = \frac{1}{2}(\log_{10} n - 1)$, $n > 0$,

then the value of n is equal to :

Options :

8643512671. 9

8643512672. 12

8643512673. 16

8643512674. 20

Question Number : 76 Question Id : 864351886 Question Type : MCQ Option Shuffling : Yes Is Question Mandatory : No

Correct Marks : 4 Wrong Marks : 1

$x \in \left(0, \frac{\pi}{2}\right)$ માટે, જો $\log_{10} \sin x + \log_{10} \cos x = -1$ અને $\log_{10}(\sin x + \cos x) = \frac{1}{2} (\log_{10} n - 1)$, $n > 0$ હોય,

તો n નું મૂલ્ય _____ છે.

Options :

8643512671. 9

8643512672. 12

8643512673. 16

8643512674. 20

Question Number : 77 Question Id : 864351887 Question Type : MCQ Option Shuffling : Yes Is Question Mandatory : No

Correct Marks : 4 Wrong Marks : 1

If $y = y(x)$ is the solution of the differential equation, $\frac{dy}{dx} + 2y \tan x = \sin x$, $y\left(\frac{\pi}{3}\right) = 0$, then

the maximum value of the function $y(x)$ over \mathbb{R} is equal to :

Options :

8643512675. 8

8643512676. $\frac{1}{2}$

8643512677. $-\frac{15}{4}$

8643512678. $\frac{1}{8}$

Question Number : 77 Question Id : 864351887 Question Type : MCQ Option Shuffling : Yes Is

Question Mandatory : No

Correct Marks : 4 Wrong Marks : 1

જો $y = y(x)$ એ વિકલ સમીકરણ $\frac{dy}{dx} + 2y \tan x = \sin x$, $y\left(\frac{\pi}{3}\right) = 0$ નો ઉકેલ હોય, તો \mathbb{R} પર વિધેય $y(x)$ નું

મહત્તમ મૂલ્ય _____ છે.

Options :

8643512675. 8

8643512676. $\frac{1}{2}$

8643512677. $-\frac{15}{4}$

8643512678. $\frac{1}{8}$

Question Number : 78 Question Id : 864351888 Question Type : MCQ Option Shuffling : Yes Is

Question Mandatory : No

Correct Marks : 4 Wrong Marks : 1

The locus of the midpoints of the chord of the circle, $x^2 + y^2 = 25$ which is tangent to the

hyperbola, $\frac{x^2}{9} - \frac{y^2}{16} = 1$ is :

Options :

8643512679. $(x^2 + y^2)^2 - 9x^2 + 144y^2 = 0$

8643512680. $(x^2 + y^2)^2 - 9x^2 - 16y^2 = 0$

8643512681. $(x^2 + y^2)^2 - 9x^2 + 16y^2 = 0$

8643512682. $(x^2 + y^2)^2 - 16x^2 + 9y^2 = 0$

Question Number : 78 Question Id : 864351888 Question Type : MCQ Option Shuffling : Yes Is

Question Mandatory : No

Correct Marks : 4 Wrong Marks : 1

અતિવલય $\frac{x^2}{9} - \frac{y^2}{16} = 1$ ને સ્પર્શક હોય તેવા વર્તુળ $x^2 + y^2 = 25$ ની જીવાનાં મધ્યબિંદુઓનો બિંદુપથ _____ છે.

Options :

8643512679. $(x^2 + y^2)^2 - 9x^2 + 144y^2 = 0$

8643512680. $(x^2 + y^2)^2 - 9x^2 - 16y^2 = 0$

8643512681. $(x^2 + y^2)^2 - 9x^2 + 16y^2 = 0$

8643512682. $(x^2 + y^2)^2 - 16x^2 + 9y^2 = 0$

Question Number : 79 Question Id : 864351889 Question Type : MCQ Option Shuffling : Yes Is Question Mandatory : No

Correct Marks : 4 Wrong Marks : 1

If the three normals drawn to the parabola, $y^2 = 2x$ pass through the point $(a, 0)$ $a \neq 0$, then 'a' must be greater than :

Options :

8643512683. 1

8643512684. -1

8643512685. $\frac{1}{2}$

8643512686. $-\frac{1}{2}$

Question Number : 79 Question Id : 864351889 Question Type : MCQ Option Shuffling : Yes Is Question Mandatory : No

Correct Marks : 4 Wrong Marks : 1

પરવલય $y^2 = 2x$ ને દોરેલ ત્રણ અભિલંબો બે બિંદુ $(a, 0)$ $a \neq 0$ માંથી પસાર થાય, તો 'a' એ _____ કરતા મોટો જ હોવો જોઈએ.

Options :

8643512683. 1

8643512684. -1

8643512685. $\frac{1}{2}$

8643512686. $-\frac{1}{2}$

Question Number : 80 Question Id : 864351890 Question Type : MCQ Option Shuffling : Yes Is Question Mandatory : No Correct Marks : 4 Wrong Marks : 1

Let a complex number z , $|z| \neq 1$, satisfy $\log_{\frac{1}{\sqrt{2}}} \left(\frac{|z| + 11}{(|z| - 1)^2} \right) \leq 2$. Then, the largest value of

$|z|$ is equal to _____.

Options :

8643512687. 5

8643512688. 6

8643512689. 7

8643512690. 8

Question Number : 80 Question Id : 864351890 Question Type : MCQ Option Shuffling : Yes Is Question Mandatory : No Correct Marks : 4 Wrong Marks : 1

ધારો કે સંકર સંખ્યા z , $|z| \neq 1$, એ $\log_{\frac{1}{\sqrt{2}}} \left(\frac{|z| + 11}{(|z| - 1)^2} \right) \leq 2$ નું સમાધાન કરે છે. તો

$|z|$ નું મહત્તમ મૂલ્ય _____ છે.

Options :

8643512687. 5

8643512688. 6

8643512689. 7

8643512690. 8

Mathematics Section B

Section Id :	86435160
Section Number :	6
Section type :	Online
Mandatory or Optional :	Mandatory
Number of Questions :	10
Number of Questions to be attempted :	5
Section Marks :	20
Mark As Answered Required? :	Yes
Sub-Section Number :	1
Sub-Section Id :	86435160
Question Shuffling Allowed :	Yes

Question Number : 81 Question Id : 864351891 Question Type : SA

Correct Marks : 4 Wrong Marks : 0

Let z and w be two complex numbers such that $w = z\bar{z} - 2z + 2$, $\left| \frac{z+i}{z-3i} \right| = 1$ and $\text{Re}(w)$

has minimum value. Then, the minimum value of $n \in \mathbb{N}$ for which w^n is real, is equal to

_____.

Response Type : Numeric

Evaluation Required For SA : Yes

Show Word Count : Yes

Answers Type : Equal

Text Areas : PlainText

Possible Answers :

100

Question Number : 81 Question Id : 864351891 Question Type : SA

Correct Marks : 4 Wrong Marks : 0

ધારો કે z અને w એ બે એવી સંકર સંખ્યાઓ છે કે જેથી $w = z\bar{z} - 2z + 2$, $\left| \frac{z+i}{z-3i} \right| = 1$ તથા $\text{Re}(w)$ ને ન્યૂનતમ

મૂલ્ય છે. તો w^n વાસ્તવિક હોય તેવા $n \in \mathbb{N}$ નું ન્યૂનતમ મૂલ્ય _____ છે.

Response Type : Numeric

Evaluation Required For SA : Yes

Show Word Count : Yes

Answers Type : Equal

Text Areas : PlainText

Possible Answers :

100

Question Number : 82 Question Id : 864351892 Question Type : SA

Correct Marks : 4 Wrong Marks : 0

Let $f: \mathbb{R} \rightarrow \mathbb{R}$ be a continuous function such that $f(x) + f(x+1) = 2$, for all $x \in \mathbb{R}$. If $I_1 = \int_0^8 f(x) dx$

and $I_2 = \int_{-1}^3 f(x) dx$, then the value of $I_1 + 2I_2$ is equal to _____.

Response Type : Numeric

Evaluation Required For SA : Yes

Show Word Count : Yes

Answers Type : Equal

Text Areas : PlainText

Possible Answers :

100

Question Number : 82 Question Id : 864351892 Question Type : SA

Correct Marks : 4 Wrong Marks : 0

ધારો કે સતત વિધેય $f: \mathbb{R} \rightarrow \mathbb{R}$ એવું છે કે જોઈ દરેક $x \in \mathbb{R}$ માટે $f(x) + f(x+1) = 2$. જો $I_1 = \int_0^8 f(x) dx$ અને

$I_2 = \int_{-1}^3 f(x) dx$ હોય, તો $I_1 + 2I_2$ નું મૂલ્ય _____ થાય.

Response Type : Numeric

Evaluation Required For SA : Yes

Show Word Count : Yes

Answers Type : Equal

Text Areas : PlainText

Possible Answers :

100

Question Number : 83 Question Id : 864351893 Question Type : SA

Correct Marks : 4 Wrong Marks : 0

If the normal to the curve $y(x) = \int_0^x (2t^2 - 15t + 10) dt$ at a point (a, b) is parallel to the line

$x + 3y = -5$, $a > 1$, then the value of $|a + 6b|$ is equal to _____.

Response Type : Numeric

Evaluation Required For SA : Yes

Show Word Count : Yes

Answers Type : Equal

Text Areas : PlainText

Possible Answers :

100

Question Number : 83 **Question Id :** 864351893 **Question Type :** SA

Correct Marks : 4 **Wrong Marks :** 0

જો બિંદુ (a, b) પાસે વક્ર $y(x) = \int_0^x (2t^2 - 15t + 10) dt$ નો અભિલંબ એ રેખા $x + 3y = -5$, $a > 1$ ને સમાંતર

હોય, તો $|a + 6b|$ નું મૂલ્ય _____ થશે.

Response Type : Numeric

Evaluation Required For SA : Yes

Show Word Count : Yes

Answers Type : Equal

Text Areas : PlainText

Possible Answers :

100

Question Number : 84 **Question Id :** 864351894 **Question Type :** SA

Correct Marks : 4 **Wrong Marks :** 0

If $\lim_{x \rightarrow 0} \frac{ae^x - b\cos x + ce^{-x}}{x \sin x} = 2$, then $a + b + c$ is equal to _____.

Response Type : Numeric

Evaluation Required For SA : Yes

Show Word Count : Yes

Answers Type : Equal

Text Areas : PlainText

Possible Answers :

100

Question Number : 84 **Question Id :** 864351894 **Question Type :** SA

Correct Marks : 4 **Wrong Marks :** 0

જો $\lim_{x \rightarrow 0} \frac{ae^x - b\cos x + ce^{-x}}{x \sin x} = 2$ હોય, તો $a + b + c =$ _____.

Response Type : Numeric

Evaluation Required For SA : Yes

Show Word Count : Yes

Answers Type : Equal

Text Areas : PlainText

Possible Answers :

100

Question Number : 85 Question Id : 864351895 Question Type : SA

Correct Marks : 4 Wrong Marks : 0

Consider an arithmetic series and a geometric series having four initial terms from the set {11, 8, 21, 16, 26, 32, 4}. If the last terms of these series are the maximum possible four digit numbers, then the number of common terms in these two series is equal to _____.

Response Type : Numeric

Evaluation Required For SA : Yes

Show Word Count : Yes

Answers Type : Equal

Text Areas : PlainText

Possible Answers :

100

Question Number : 85 Question Id : 864351895 Question Type : SA

Correct Marks : 4 Wrong Marks : 0

જોના શરૂઆતમાં ચાર પદો ગણ {11, 8, 21, 16, 26, 32, 4} માંથી હોય તેવી સમાંતર શ્રેણી તથા સમગુણોત્તર શ્રેણી ગણતરીમાં લો. જો આ શ્રેણીઓનાં છેલ્લા પદો એ ચાર અંકની શક્ય મહત્તમ સંખ્યાઓ હોય, તો આ બંને શ્રેણીઓનાં સામાન્ય પદોની સંખ્યા _____ છે.

Response Type : Numeric

Evaluation Required For SA : Yes

Show Word Count : Yes

Answers Type : Equal

Text Areas : PlainText

Possible Answers :

100

Question Number : 86 Question Id : 864351896 Question Type : SA

Correct Marks : 4 Wrong Marks : 0

Let $P = \begin{bmatrix} -30 & 20 & 56 \\ 90 & 140 & 112 \\ 120 & 60 & 14 \end{bmatrix}$ and $A = \begin{bmatrix} 2 & 7 & \omega^2 \\ -1 & -\omega & 1 \\ 0 & -\omega & -\omega+1 \end{bmatrix}$ where $\omega = \frac{-1 + i\sqrt{3}}{2}$, and I_3 be the

identity matrix of order 3. If the determinant of the matrix $(P^{-1}AP - I_3)^2$ is $\alpha\omega^2$, then the value of α is equal to _____.

Response Type : Numeric

Evaluation Required For SA : Yes

Show Word Count : Yes

Answers Type : Equal

Text Areas : PlainText

Possible Answers :

100

Question Number : 86 Question Id : 864351896 Question Type : SA

Correct Marks : 4 Wrong Marks : 0

ધારોકે $P = \begin{bmatrix} -30 & 20 & 56 \\ 90 & 140 & 112 \\ 120 & 60 & 14 \end{bmatrix}$ અને $A = \begin{bmatrix} 2 & 7 & \omega^2 \\ -1 & -\omega & 1 \\ 0 & -\omega & -\omega+1 \end{bmatrix}$, જ્યાં $\omega = \frac{-1 + i\sqrt{3}}{2}$, અને I_3 એ કક્ષા 3

નો એકમ શ્રેણિક છે. જો શ્રેણિક $(P^{-1}AP - I_3)^2$ નો નિશ્ચાયક $\alpha\omega^2$ હોય, તો α નું મૂલ્ય _____ છે.

Response Type : Numeric

Evaluation Required For SA : Yes

Show Word Count : Yes

Answers Type : Equal

Text Areas : PlainText

Possible Answers :

100

Question Number : 87 Question Id : 864351897 Question Type : SA

Correct Marks : 4 Wrong Marks : 0

Let $f: (0, 2) \rightarrow \mathbb{R}$ be defined as $f(x) = \log_2\left(1 + \tan\left(\frac{\pi x}{4}\right)\right)$.

Then, $\lim_{n \rightarrow \infty} \frac{2}{n} \left(f\left(\frac{1}{n}\right) + f\left(\frac{2}{n}\right) + \dots + f(1) \right)$ is equal to _____.

Response Type : Numeric

Evaluation Required For SA : Yes

Show Word Count : Yes

Answers Type : Equal

Text Areas : PlainText

Possible Answers :

100

Question Number : 87 Question Id : 864351897 Question Type : SA

Correct Marks : 4 Wrong Marks : 0

ધારો કે $f: (0, 2) \rightarrow \mathbb{R}$ એ $f(x) = \log_2 \left(1 + \tan\left(\frac{\pi x}{4}\right) \right)$ મુજબ વ્યાખ્યાયિત છે. તો

$$\lim_{n \rightarrow \infty} \frac{2}{n} \left(f\left(\frac{1}{n}\right) + f\left(\frac{2}{n}\right) + \dots + f(1) \right) = \underline{\hspace{2cm}}$$

Response Type : Numeric

Evaluation Required For SA : Yes

Show Word Count : Yes

Answers Type : Equal

Text Areas : PlainText

Possible Answers :

100

Question Number : 88 Question Id : 864351898 Question Type : SA

Correct Marks : 4 Wrong Marks : 0

The total number of 3×3 matrices A having entries from the set $\{0, 1, 2, 3\}$ such that the sum of all the diagonal entries of AA^T is 9, is equal to _____.

Response Type : Numeric

Evaluation Required For SA : Yes

Show Word Count : Yes

Answers Type : Equal

Text Areas : PlainText

Possible Answers :

100

Question Number : 88 Question Id : 864351898 Question Type : SA

Correct Marks : 4 Wrong Marks : 0

જેનાં બધાં ઘટકો ગણ $\{0, 1, 2, 3\}$ માંથી આવેલ હોય તથા AA^T નાં વિકર્ણી ઘટકોનો સરવાળો 9 હોય તેવા 3×3 શ્રેણિક A ની કુલ સંખ્યા _____ છે.

Response Type : Numeric

Evaluation Required For SA : Yes

Show Word Count : Yes

Answers Type : Equal

Text Areas : PlainText

Possible Answers :

100

Question Number : 89 Question Id : 864351899 Question Type : SA

Correct Marks : 4 Wrong Marks : 0

Let ABCD be a square of side of unit length. Let a circle C_1 centered at A with unit radius is drawn. Another circle C_2 which touches C_1 and the lines AD and AB are tangent to it, is also drawn. Let a tangent line from the point C to the circle C_2 meet the side AB at E. If the length of EB is $\alpha + \sqrt{3} \beta$, where α, β are integers, then $\alpha + \beta$ is equal to _____.

Response Type : Numeric

Evaluation Required For SA : Yes

Show Word Count : Yes

Answers Type : Equal

Text Areas : PlainText

Possible Answers :

100

Question Number : 89 Question Id : 864351899 Question Type : SA

Correct Marks : 4 Wrong Marks : 0

ધારો કે ABCD એ એકમ બાજુઓ વાળો ચોરસ છે. ધારો કે A પર કેન્દ્રિત એકમ ત્રિજ્યાવાળો વર્તુળ C_1 દોરવામાં આવે છે. C_1 ને સ્પર્શતો અને રેખાઓ AD અને AB જેનાં સ્પર્શક હોય તેવો અન્ય વર્તુળ C_2 પણ દોરવામાં આવે છે. ધારો કે બિંદુ C માંથી વર્તુળ C_2 પર દોરેલ સ્પર્શક બાજુ AB ને E માં મળે છે. જો α, β પૂર્ણાંકો હોય અને EB ની લંબાઈ $\alpha + \sqrt{3} \beta$ હોય, તો $\alpha + \beta =$ _____.

Response Type : Numeric

Evaluation Required For SA : Yes

Show Word Count : Yes

Answers Type : Equal

Text Areas : PlainText

Possible Answers :

100

Question Number : 90 Question Id : 864351900 Question Type : SA

Correct Marks : 4 Wrong Marks : 0

Let the curve $y = y(x)$ be the solution of the differential equation, $\frac{dy}{dx} = 2(x + 1)$. If the numerical value of area bounded by the curve $y = y(x)$ and x -axis is $\frac{4\sqrt{8}}{3}$, then the value of $y(1)$ is equal to _____.

Response Type : Numeric

Evaluation Required For SA : Yes

Show Word Count : Yes

Answers Type : Equal

Text Areas : PlainText

Possible Answers :

100

Question Number : 90 **Question Id :** 864351900 **Question Type :** SA

Correct Marks : 4 **Wrong Marks :** 0

ધારો કે વક્ર $y = y(x)$ એ વિકલ સમીકરણ $\frac{dy}{dx} = 2(x + 1)$ નો ઉકેલ છે. જો વક્ર $y = y(x)$ તથા x -અક્ષ દ્વારા સંવૃત્ત

ક્ષેત્રફળની સંખ્યાત્મક કિંમત $\frac{4\sqrt{8}}{3}$ હોય, તો $y(1)$ નું મૂલ્ય _____ છે.

Response Type : Numeric

Evaluation Required For SA : Yes

Show Word Count : Yes

Answers Type : Equal

Text Areas : PlainText

Possible Answers :

100