

National Testing Agency

Question Paper Name :	B TECH EO 16th March 2021 Shift 1
Subject Name :	B TECH EO
Creation Date :	2021-03-16 14:04:33
Duration :	180
Number of Questions :	90
Total Marks :	300
Display Marks:	Yes

B TECH EO

Group Number :	1
Group Id :	8643516
Group Maximum Duration :	0
Group Minimum Duration :	180
Show Attended Group? :	No
Edit Attended Group? :	No
Break time :	0
Group Marks :	300
Is this Group for Examiner? :	No

Physics Section A

Section Id :	86435131
Section Number :	1
Section type :	Online
Mandatory or Optional :	Mandatory
Number of Questions :	20
Number of Questions to be attempted :	20
Section Marks :	80
Mark As Answered Required? :	Yes
Sub-Section Number :	1
Sub-Section Id :	86435131
Question Shuffling Allowed :	Yes

Question Number : 1 Question Id : 864351451 Question Type : MCQ Option Shuffling : Yes Is Question Mandatory : No

Correct Marks : 4 Wrong Marks : 1

For an electromagnetic wave travelling in free space, the relation between average energy densities due to electric (U_e) and magnetic (U_m) fields is :

Options :

8643511351. $U_e = U_m$

8643511352. $U_e \neq U_m$

8643511353. $U_e > U_m$

8643511354. $U_e < U_m$

Question Number : 1 Question Id : 864351451 Question Type : MCQ Option Shuffling : Yes Is Question Mandatory : No

Correct Marks : 4 Wrong Marks : 1

ଶୂନ୍ୟରେ ଗତି କରୁଥିବା ଗୋଟିଏ ବିଦ୍ୟୁତ୍ ଚୁମ୍ବକୀୟ ଚରଙ୍କ ପାଇଁ, ବିଦ୍ୟୁତ୍ କ୍ଷେତ୍ର ଯୋଗୁଁ ଶକ୍ତି ସାହଚ୍ୟ (U_e) ଏବଂ ଚୁମ୍ବକୀୟ କ୍ଷେତ୍ର ଶକ୍ତି ସାହଚ୍ୟ (U_m) ଦ୍ୱୟ ପାଇଁ ହାରାହାରି ସମ୍ପର୍କଟି ହେଉଛି :

Options :

8643511351. $U_e = U_m$

8643511352. $U_e \neq U_m$

8643511353. $U_e > U_m$

8643511354. $U_e < U_m$

Question Number : 2 Question Id : 864351452 Question Type : MCQ Option Shuffling : Yes Is Question Mandatory : No

Correct Marks : 4 Wrong Marks : 1

The volume V of an enclosure contains a mixture of three gases, 16 g of oxygen, 28 g of nitrogen and 44 g of carbon dioxide at absolute temperature T . Consider R as universal gas constant. The pressure of the mixture of gases is :

Options :

8643511355. $\frac{5}{2} \frac{RT}{V}$

8643511356. $\frac{3RT}{V}$

8643511357. $\frac{4RT}{V}$

8643511358. $\frac{88RT}{V}$

Question Number : 2 Question Id : 864351452 Question Type : MCQ Option Shuffling : Yes Is Question Mandatory : No

Correct Marks : 4 Wrong Marks : 1

V ଆୟତନର ଏକ ଆବକ ପାତ୍ର ପରମ ତାପମାତ୍ରା T ରେ ତିନିଗୋଟି ଗ୍ୟାସ୍ ଯଥା 16 g ର ଅମ୍ଳଜାନ, 28 g ର ଯକ୍ଷାରଜାନ ଏବଂ 44 g ର ଅଜ୍ଞାତଗ୍ୟାସ୍ ବାଷ୍ପ ଧାରଣ କରୁଅଛି । ବିଚାର କର ସାବିତ୍ରିକ୍ତ ଗ୍ୟାସ୍ ଧୁବାଙ୍କ R ଅଟେ । ଏହି ଗ୍ୟାସ୍ ମିଶ୍ରଣର ଚାପ ହେବ :

Options :

8643511355. $\frac{5}{2} \frac{RT}{V}$

8643511356. $\frac{3RT}{V}$

8643511357. $\frac{4RT}{V}$

8643511358. $\frac{88RT}{V}$

Question Number : 3 Question Id : 864351453 Question Type : MCQ Option Shuffling : Yes Is Question Mandatory : No

Correct Marks : 4 Wrong Marks : 1

For changing the capacitance of a given parallel plate capacitor, a dielectric material of dielectric constant K is used, which has the same area as the plates of the capacitor. The thickness of the dielectric slab is $\frac{3}{4}d$, where 'd' is the separation between the plates of parallel plate capacitor. The new capacitance (C') in terms of original capacitance (C₀) is given by the following relation :

Options :

8643511359.
$$C' = \frac{4K}{K+3}C_0$$

8643511360.
$$C' = \frac{4}{3+K}C_0$$

8643511361.
$$C' = \frac{3+K}{4K}C_0$$

8643511362.
$$C' = \frac{4+K}{3}C_0$$

Question Number : 3 Question Id : 864351453 Question Type : MCQ Option Shuffling : Yes Is Question Mandatory : No

Correct Marks : 4 Wrong Marks : 1

ଦିଆଯାଇଥିବା ସମାନ୍ତରାଳ ପ୍ଲେଟ୍‌ଧାରିତ୍ରର ଧାରିତାକୁ ବଦଳାଇବା ପାଇଁ, ପରାବୈଦ୍ୟୁତାଙ୍କ K ଥିବା ଏକ ପଦାର୍ଥକୁ ବ୍ୟବହାର କରାଗଲା, ଯାହାର କ୍ଷେତ୍ରଫଳ ଧାରିତ୍ରର ପ୍ଲେଟର କ୍ଷେତ୍ରଫଳ ସହ ସମାନ । ପରାବୈଦ୍ୟୁତାଙ୍କ ସ୍ଥାବର ମୋଟେଇ $\frac{3}{4}d$ ଥିଲେ, ଯେଉଁଠାରେ 'd' ହେଉଛି ଧାରିତ୍ରର ପ୍ଲେଟ୍ ଦୁଇଟି ମଧ୍ୟରେ ବ୍ୟବଧାନ । ମୂଳ ଧାରିତା (C_0) ଆକାରରେ ନୂତନ ଧାରିତା (C') ସମ୍ପର୍କକୁ ଦର୍ଶାଯାଇପାରିବ ।

Options :

8643511359.
$$C' = \frac{4K}{K+3}C_0$$

8643511360.
$$C' = \frac{4}{3+K}C_0$$

8643511361.
$$C' = \frac{3+K}{4K}C_0$$

8643511362.
$$C' = \frac{4+K}{3}C_0$$

Question Number : 4 Question Id : 864351454 Question Type : MCQ Option Shuffling : Yes Is Question Mandatory : No

Correct Marks : 4 Wrong Marks : 1

The velocity-displacement graph describing the motion of a bicycle is shown in the figure.

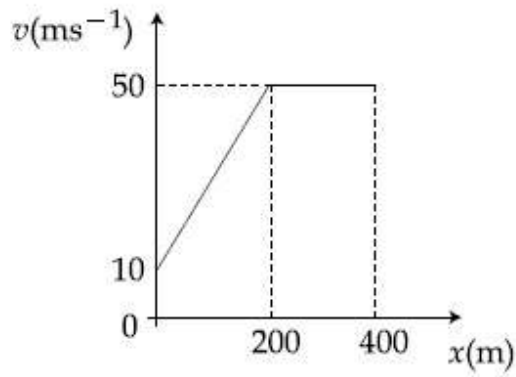

The acceleration-displacement graph of the bicycle's motion is best described by :

Options :

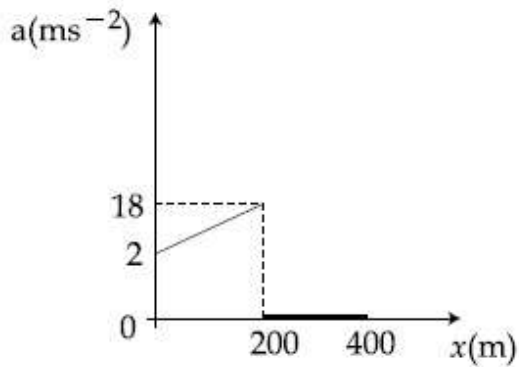

8643511363.

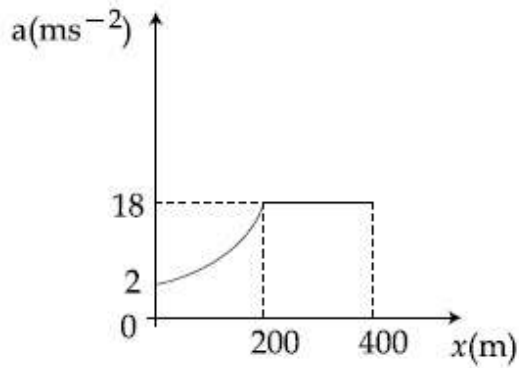

8643511364.

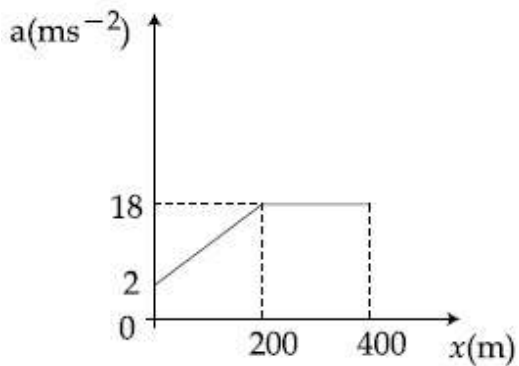

8643511365.

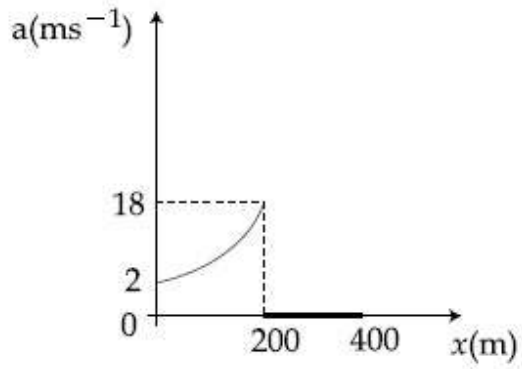

8643511366.

Question Number : 4 Question Id : 864351454 Question Type : MCQ Option Shuffling : Yes Is Question Mandatory : No

Correct Marks : 4 Wrong Marks : 1

ଗୋଟିଏ ଗତିଶୀଳ ସାଇକେଲର ପରିବେଗ-ବିସ୍ଥାପନକୁ ବର୍ଣ୍ଣନା କରୁଥିବା ଲେଖଚିତ୍ରଟି ଅଟେ :

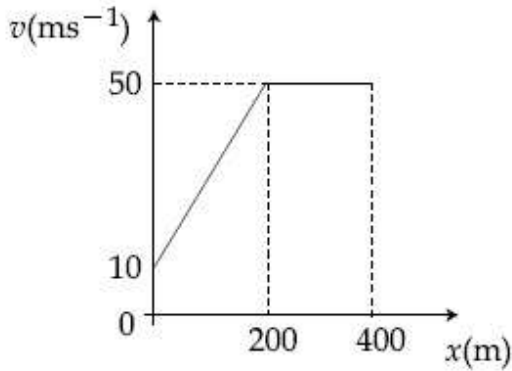

ଏହି ସାଇକେଲ ଗତିର ସର୍ବୋଚ୍ଚ ଗତି ଉପରେ ବର୍ଣ୍ଣନା କରାଯାଇଥିବା ଦୂରଣ-ବିସ୍ଥାପନ ଲେଖଚିତ୍ର ହେବ :

Options :

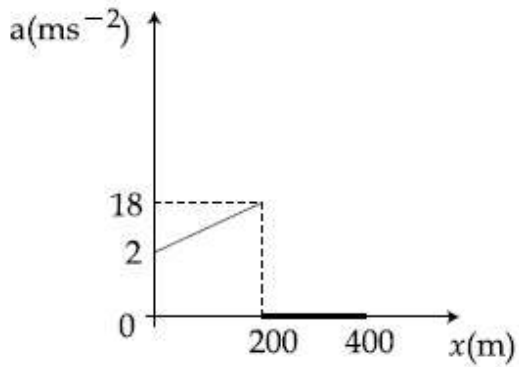

8643511363.

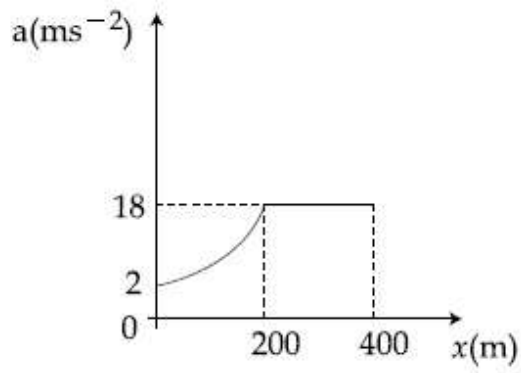

8643511364.

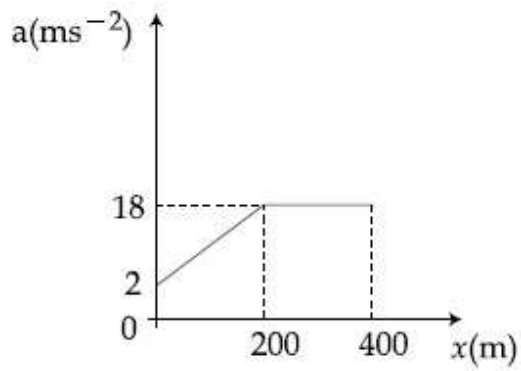

8643511365.

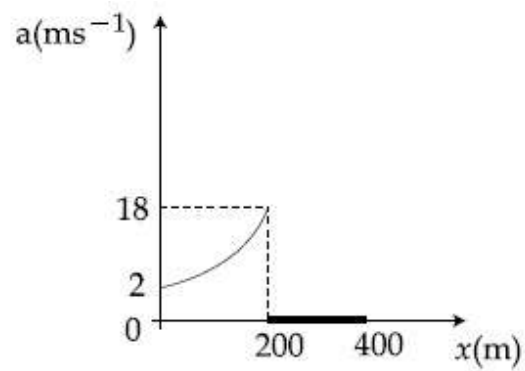

8643511366.

Question Number : 5 Question Id : 864351455 Question Type : MCQ Option Shuffling : Yes Is Question Mandatory : No

Correct Marks : 4 Wrong Marks : 1

A block of mass m slides along a floor while a force of magnitude F is applied to it at an angle θ as shown in figure. The coefficient of kinetic friction is μ_K . Then, the block's acceleration 'a' is given by :

(g is acceleration due to gravity)

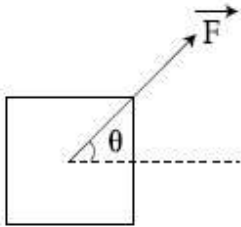

Options :

8643511367. $-\frac{F}{m}\cos\theta - \mu_K\left(g - \frac{F}{m}\sin\theta\right)$

8643511368. $\frac{F}{m}\cos\theta + \mu_K\left(g - \frac{F}{m}\sin\theta\right)$

8643511369. $\frac{F}{m}\cos\theta - \mu_K\left(g + \frac{F}{m}\sin\theta\right)$

8643511370. $\frac{F}{m}\cos\theta - \mu_K\left(g - \frac{F}{m}\sin\theta\right)$

Question Number : 5 Question Id : 864351455 Question Type : MCQ Option Shuffling : Yes Is Question Mandatory : No

Correct Marks : 4 Wrong Marks : 1

ଚିତ୍ରରେ ଦର୍ଶାଯାଇଥିବା ଅନୁସାରେ m ବସ୍ତୁକୁ ବିଶିଷ୍ଟ ଗୋଟିଏ ବ୍ଲକ୍ ଉପରେ θ କୋଣରେ F ପରିମାଣର ବଳ ପ୍ରୟୋଗ କରି ଚୋଗରେ ଚଳାଯାଇଛି । ଗତିଜ ଘର୍ଷଣ ଧ୍ରୁବାଙ୍କ μ_K ଅଟେ । ତେବେ ବ୍ଲକ୍‌ଟିର ତ୍ୱରଣ 'a' କୁ ଦର୍ଶାଯାଇପାରିବ :
(g = ମାଧ୍ୟାକର୍ଷଣ ଜନିତ ତ୍ୱରଣ)

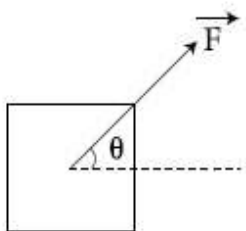

Options :

8643511367. $-\frac{F}{m}\cos\theta - \mu_K\left(g - \frac{F}{m}\sin\theta\right)$

8643511368. $\frac{F}{m}\cos\theta + \mu_K\left(g - \frac{F}{m}\sin\theta\right)$

8643511369. $\frac{F}{m}\cos\theta - \mu_K\left(g + \frac{F}{m}\sin\theta\right)$

8643511370. $\frac{F}{m}\cos\theta - \mu_K\left(g - \frac{F}{m}\sin\theta\right)$

Question Number : 6 Question Id : 864351456 Question Type : MCQ Option Shuffling : Yes Is Question Mandatory : No

Correct Marks : 4 Wrong Marks : 1

A bar magnet of length 14 cm is placed in the magnetic meridian with its north pole pointing towards the geographic north pole. A neutral point is obtained at a distance of 18 cm from the center of the magnet. If $B_H = 0.4$ G, the magnetic moment of the magnet is ($1 \text{ G} = 10^{-4}\text{T}$)

Options :

8643511371. 28.80 J T^{-1}

8643511372. $2.880 \times 10^2 \text{ J T}^{-1}$

8643511373. 2.880 J T^{-1}

8643511374. $2.880 \times 10^3 \text{ J T}^{-1}$

Question Number : 6 Question Id : 864351456 Question Type : MCQ Option Shuffling : Yes Is Question Mandatory : No

Correct Marks : 4 Wrong Marks : 1

14 cm ଦୈର୍ଘ୍ୟ ବିଶିଷ୍ଟ ଗୋଟିଏ ଦଣ୍ଡଚୁମ୍ବକକୁ ଏହାର ଉତ୍ତରପେରୁକୁ ଭୂଗୋଳକାନ୍ଦ ଉତ୍ତରପେରୁ ଦିଗରେ ମୁହାଁଇ ଚୁମ୍ବକୀୟ ଦ୍ରାଘିମା (ମେରିଡିଆନ)ରେ ରଖାଗଲା । ଚୁମ୍ବକର କେନ୍ଦ୍ରଠାରୁ 18 cm ଦୂରତାରେ ଏକ ଦୁ୍ୟତ୍ରୀୟ ପଏଣ୍ଟ ମିଳିଲା । ଯଦି $B_H = 0.4$ G, ଚୁମ୍ବକଟିର ଚୁମ୍ବକୀୟ ଆୟତ୍ତ ହେବ :

($1 \text{ G} = 10^{-4}\text{T}$)

Options :

8643511371. 28.80 J T^{-1}

8643511372. $2.880 \times 10^2 \text{ J T}^{-1}$

8643511373. 2.880 J T^{-1}

8643511374. $2.880 \times 10^3 \text{ J T}^{-1}$

Question Number : 7 Question Id : 864351457 Question Type : MCQ Option Shuffling : Yes Is Question Mandatory : No

Correct Marks : 4 Wrong Marks : 1

The angle of deviation through a prism is minimum when

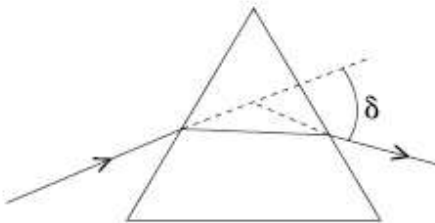

- (A) Incident ray and emergent ray are symmetric to the prism
- (B) The refracted ray inside the prism becomes parallel to its base
- (C) Angle of incidence is equal to that of the angle of emergence
- (D) When angle of emergence is double the angle of incidence

Choose the correct answer from the options given below :

Options :

8643511375. Only statements (A) and (B) are true

8643511376. Statements (A), (B) and (C) are true

8643511377. Only statement (D) is true

8643511378. Statements (B) and (C) are true

Question Number : 7 Question Id : 864351457 Question Type : MCQ Option Shuffling : Yes Is Question Mandatory : No

Correct Marks : 4 Wrong Marks : 1

ପ୍ରିଜମ୍ ମଧ୍ୟରେ ଯାଉଥିବା ଏକ ରଶ୍ମି ପାଇଁ ବିଚଳନ କୋଣ ସର୍ବନିମ୍ନ ଅଟେ ଯେତେବେଳେ

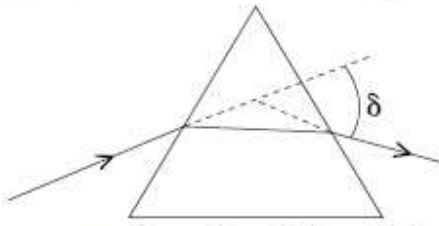

- (A) ଆପତିତ ରଶ୍ମି ଓ ନିର୍ଗତ ରଶ୍ମି ପ୍ରିଜମ୍ ସହିତ ପ୍ରତିସମ ହୋଇଥାଏ ।
- (B) ପ୍ରିଜମ୍ ମଧ୍ୟରେ ପ୍ରତିସରିତ ରଶ୍ମିଟି ପ୍ରିଜମ୍‌ର ଭୂମି ସହ ସମାନ୍ତର ହୋଇଥାଏ ।
- (C) ଆପତିତ କୋଣ ଓ ନିର୍ଗତ କୋଣ ଦୁଇଟି ସମାନ ହୋଇଥାଏ ।
- (D) ଯେତେବେଳେ ନିର୍ଗତ କୋଣଟି ଆପତିତ କୋଣର ଦୁଇଗୁଣ ହୋଇଥାଏ ।

ତଳେ ଦିଆଯାଇଥିବା ବିକଳଗୁଡ଼ିକରୁ ଠିକ୍ ଉତ୍ତରଟି ଚୟନ କର :

Options :

8643511375. କେବଳ ଉକ୍ତି (A) ଏବଂ (B) ଠିକ୍ ଅଟନ୍ତି

8643511376. ଉକ୍ତି (A), (B) ଏବଂ (C) ଠିକ୍ ଅଟନ୍ତି

8643511377. କେବଳ (D) ଠିକ୍ ଅଟେ

8643511378. ଉକ୍ତି (B) ଏବଂ (C) ସଠିକ୍ ଅଟନ୍ତି

Question Number : 8 Question Id : 864351458 Question Type : MCQ Option Shuffling : Yes Is Question Mandatory : No

Correct Marks : 4 Wrong Marks : 1

An RC circuit as shown in the figure is driven by a AC source generating a square wave. The output wave pattern monitored by CRO would look close to :

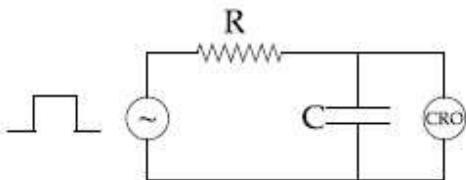

Options :

8643511379.

8643511380.

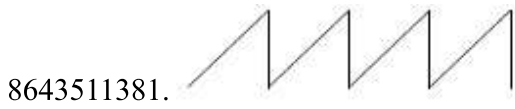

Question Number : 8 Question Id : 864351458 Question Type : MCQ Option Shuffling : Yes Is Question Mandatory : No

Correct Marks : 4 Wrong Marks : 1

ଚିତ୍ରରେ ଦର୍ଶାଯାଇଥିବା ଅନୁସାରେ ବର୍ଗାକାର (ସ୍କୋୟାର) ତରଙ୍ଗ ସୃଷ୍ଟି କରୁଥିବା ଏକ ପ୍ରତ୍ୟାବର୍ତ୍ତୀ ବିଦ୍ୟୁତ୍ ଉତ୍ସ (ଏ.ସି. ସୋର୍ସ) ଦ୍ୱାରା RC ପରିପଥକୁ ଚଳାଯାଇଛି । CRO ଦ୍ୱାରା ଦର୍ଶାଯାଇଥିବା ଆଉଟପୁଟ୍ ତରଙ୍ଗର ଆକାର ପାଖାପାଖି ଦେଖାଯିବ :

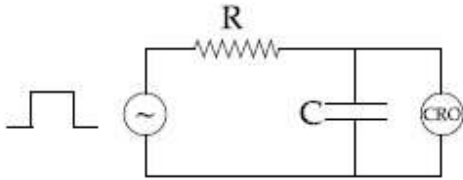

Options :

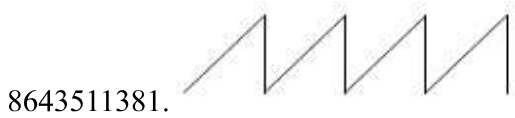
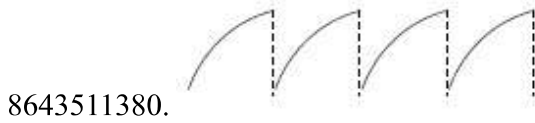

Question Number : 9 Question Id : 864351459 Question Type : MCQ Option Shuffling : Yes Is Question Mandatory : No

Correct Marks : 4 Wrong Marks : 1

A block of 200 g mass moves with a uniform speed in a horizontal circular groove, with vertical side walls of radius 20 cm. If the block takes 40 s to complete one round, the normal force by the side walls of the groove is :

Options :

8643511383. 0.0314 N

8643511384. 9.859×10^{-4} N

8643511385. 6.28×10^{-3} N

8643511386. 9.859×10^{-2} N

Question Number : 9 Question Id : 864351459 Question Type : MCQ Option Shuffling : Yes Is Question Mandatory : No

Correct Marks : 4 Wrong Marks : 1

ଭୂଲୟାୟ ପାର୍ଶ୍ୱକାନ୍ଧ ଥିବା 20 cm ବ୍ୟାସାର୍ଦ୍ଧ ବିଶିଷ୍ଟ ଗୋଟିଏ ଭୂସମାନ୍ତର ବୃତ୍ତାକାର ନଳା (ଗୁଡ) ରେ 200 g ବସ୍ତୁ ବିଶିଷ୍ଟ ଗୋଟିଏ ବ୍ଲକ୍ ସମଗତିରେ ଗତି କରୁଅଛି । ଯଦି ବ୍ଲକ୍ଟି ପୂରା ବୁଲି ଆସିବା ପାଇଁ 40 ସେକେଣ୍ଡ ସମୟ ନେଉଥାଏ, ଗୁଡ୍ଟିର ପାର୍ଶ୍ୱ କାନ୍ଧରେ ପଡୁଥିବା ଲୟାୟ ସ୍ୱର୍ଗ ବଳ (ନରମାଲ ଫୋର୍ସ) ହେବ :

Options :

8643511383. 0.0314 N

8643511384. 9.859×10^{-4} N

8643511385. 6.28×10^{-3} N

8643511386. 9.859×10^{-2} N

Question Number : 10 Question Id : 864351460 Question Type : MCQ Option Shuffling : Yes Is Question Mandatory : No

Correct Marks : 4 Wrong Marks : 1

In thermodynamics, heat and work are :

Options :

8643511387. Point functions

8643511388. Path functions

8643511389. Intensive thermodynamic state variables

8643511390. Extensive thermodynamic state variables

Question Number : 10 Question Id : 864351460 Question Type : MCQ Option Shuffling : Yes Is Question Mandatory : No

Correct Marks : 4 Wrong Marks : 1

ତାପଗତିକ ବିଜ୍ଞାନରେ, ତାପ ଏବଂ କାର୍ଯ୍ୟ ହେଉଛି :

Options :

8643511387. ପଏଣ୍ଟ୍ ଫଙ୍କସନ୍

8643511388. ପାଥ୍ ଫଙ୍କସନ୍

8643511389. ଇଣ୍ଟେନ୍ସିଭ୍ ତାପଗତିକ ଛିତିର ଚଳରାଶି

8643511390. ଏକ୍ସଟେନ୍ସିଭ୍ ତାପଗତିକ ଛିତିର ଚଳରାଶି

Question Number : 11 Question Id : 864351461 Question Type : MCQ Option Shuffling : Yes Is Question Mandatory : No

Correct Marks : 4 Wrong Marks : 1

The maximum and minimum distances of a comet from the Sun are 1.6×10^{12} m and 8.0×10^{10} m respectively. If the speed of the comet at the nearest point is 6×10^4 ms⁻¹, the speed at the farthest point is :

Options :

8643511391. 1.5×10^3 m/s

8643511392. 3.0×10^3 m/s

8643511393. 6.0×10^3 m/s

8643511394. 4.5×10^3 m/s

Question Number : 11 Question Id : 864351461 Question Type : MCQ Option Shuffling : Yes Is Question Mandatory : No

Correct Marks : 4 Wrong Marks : 1

ସୂର୍ଯ୍ୟଠାରୁ ଗୋଟିଏ ଧୂମକେତୁ (କେମେଟ୍) ର ସର୍ବାଧିକ ଓ ସର୍ବନିମ୍ନ ଦୂରତା ଯଥାକ୍ରମେ 1.6×10^{12} m ଏବଂ 8.0×10^{10} m ଅଟେ । ଯଦି ନିକଟତମ ବିନ୍ଦୁରେ ଥିବାବେଳେ ଧୂମକେତୁର ବେଗ 6×10^4 ms⁻¹ ହୁଏ, ତେବେ ଦୂରତମ ବିନ୍ଦୁରେ ଥିବାବେଳେ ଏହାର ବେଗ ହେବ :

Options :

8643511391. 1.5×10^3 m/s

8643511392. 3.0×10^3 m/s

8643511393. $6.0 \times 10^3 \text{ m/s}$

8643511394. $4.5 \times 10^3 \text{ m/s}$

Question Number : 12 Question Id : 864351462 Question Type : MCQ Option Shuffling : Yes Is Question Mandatory : No

Correct Marks : 4 Wrong Marks : 1

Four equal masses, m each are placed at the corners of a square of length (l) as shown in the figure. The moment of inertia of the system about an axis passing through A and parallel to DB would be :

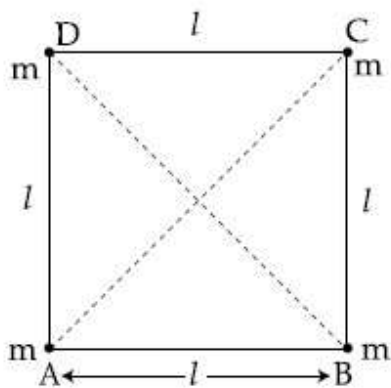

Options :

8643511395. $2 ml^2$

8643511396. $\sqrt{3} ml^2$

8643511397. $3 ml^2$

8643511398. ml^2

Question Number : 12 Question Id : 864351462 Question Type : MCQ Option Shuffling : Yes Is Question Mandatory : No

Correct Marks : 4 Wrong Marks : 1

ଚିତ୍ରରେ ଦର୍ଶାଯାଇଥିବା ଅନୁସାରେ, ଚାରୋଟି ସମାନ ବସ୍ତୁତ୍ୱ (m) କୁ l ଦୈର୍ଘ୍ୟ ବିଶିଷ୍ଟ ବର୍ଗକ୍ଷେତ୍ରର ଚାରି କୋଣ ରଖାଯାଇଛି ।
DB ସହ ସମାନ୍ତର ହୋଇ A ବିନ୍ଦୁ ଦେଇ ଯାଇଥିବା ଅକ୍ଷ ଚାରିପଟେ ଏହି ସମୂହଟିର ଆୟତ୍ତ୍ୱ ଜଡ଼ତ୍ୱ ହେବ :

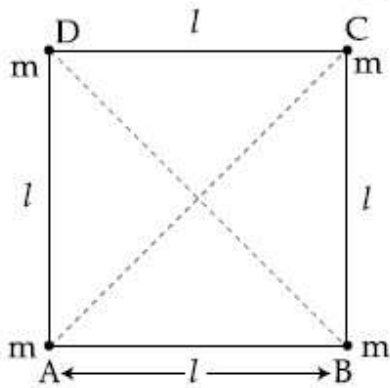

Options :

8643511395. $2 ml^2$

8643511396. $\sqrt{3} ml^2$

8643511397. $3 ml^2$

8643511398. ml^2

Question Number : 13 Question Id : 864351463 Question Type : MCQ Option Shuffling : Yes Is Question Mandatory : No

Correct Marks : 4 Wrong Marks : 1

A 25 m long antenna is mounted on an antenna tower. The height of the antenna tower is 75 m. The wavelength (in meter) of the signal transmitted by this antenna would be :

Options :

8643511399. 200

8643511400. 300

8643511401. 400

8643511402. 100

Question Number : 13 Question Id : 864351463 Question Type : MCQ Option Shuffling : Yes Is Question Mandatory : No

Correct Marks : 4 Wrong Marks : 1

ଗୋଟିଏ ଆଣ୍ଡେନା ଟାଓ୍ଵାର ଉପରେ 25 m ଦୈର୍ଘ୍ୟର ଏକ ଆଣ୍ଡେନା ସ୍ଥାପନା କରାଯାଇଅଛି । ଆଣ୍ଡେନା ଟାଓ୍ଵାରର ଉଚ୍ଚତା 75 m ଅଟେ । ଏହି ଆଣ୍ଡେନା ଦ୍ଵାରା ପ୍ରସାରିତ ସଂକେତର ଚରଙ୍ଗ ଦୈର୍ଘ୍ୟ (ମିଟରରେ) ହେବ :

Options :

8643511399. 200

8643511400. 300

8643511401. 400

8643511402. 100

Question Number : 14 Question Id : 864351464 Question Type : MCQ Option Shuffling : Yes Is Question Mandatory : No

Correct Marks : 4 Wrong Marks : 1

The stopping potential in the context of photoelectric effect depends on the following property of incident electromagnetic radiation :

Options :

8643511403. Frequency

8643511404. Amplitude

8643511405. Intensity

8643511406. Phase

Question Number : 14 Question Id : 864351464 Question Type : MCQ Option Shuffling : Yes Is Question Mandatory : No

Correct Marks : 4 Wrong Marks : 1

ଆଲୋକ-ବିଦ୍ୟୁତ୍ ପ୍ରଭାବ ପ୍ରସଙ୍ଗରେ, ନିରୋଧ ବିଭବ(ଷ୍ଟପିଙ୍ଗ୍ ପୋଟେନସିଆଲ) ଟି ବିଦ୍ୟୁତ୍ ବୁଲ୍‌କାନ୍ଦ ବିକିରଣର କେଉଁ ସ୍ଵଭାବ ଉପରେ ନିର୍ଭର କରିଥାଏ ?

Options :

8643511403. ଆବୃତ୍ତି

8643511404. ଆକାମ

8643511405. ତୀବ୍ରତା

8643511406. କଳା (ଫେଜ୍)

Question Number : 15 Question Id : 864351465 Question Type : MCQ Option Shuffling : Yes Is Question Mandatory : No

Correct Marks : 4 Wrong Marks : 1

Time period of a simple pendulum is T inside a lift when the lift is stationary. If the lift moves upwards with an acceleration $g/2$, the time period of pendulum will be :

Options :

8643511407. $\frac{T}{\sqrt{3}}$

8643511408. $\sqrt{3}T$

8643511409. $\sqrt{\frac{3}{2}} T$

8643511410. $\sqrt{\frac{2}{3}} T$

Question Number : 15 Question Id : 864351465 Question Type : MCQ Option Shuffling : Yes Is Question Mandatory : No

Correct Marks : 4 Wrong Marks : 1

ଲିଫ୍ଟ୍ ଛିର ଥିବାବେଳେ, ଏହା ମଧ୍ୟରେ ଥିବା ଏକ ସରଳ ପେଣ୍ଡୁଲମ୍ ଆବର୍ତ୍ତକାଳ T ଅଟେ । ଯଦି ଲିଫ୍ଟ୍ଟି ଉପରକୁ $g/2$ ଦ୍ରୁତତାରେ ଗତିକରେ ତେବେ ପେଣ୍ଡୁଲମ୍ ଆବର୍ତ୍ତକାଳ ହେବ :

Options :

8643511407. $\frac{T}{\sqrt{3}}$

8643511408. $\sqrt{3}T$

8643511409. $\sqrt{\frac{3}{2}} T$

8643511410. $\sqrt{\frac{2}{3}} T$

Question Number : 16 Question Id : 864351466 Question Type : MCQ Option Shuffling : Yes Is Question Mandatory : No

Correct Marks : 4 Wrong Marks : 1

A plane electromagnetic wave of frequency 500 MHz is travelling in vacuum along y -direction.

At a particular point in space and time, $\vec{B} = 8.0 \times 10^{-8} \hat{z} \text{ T}$. The value of electric field at this point is :

(speed of light = $3 \times 10^8 \text{ ms}^{-1}$)

\hat{x} , \hat{y} , \hat{z} are unit vectors along x , y and z directions.

Options :

8643511411. $-24 \hat{x} \text{ V/m}$

8643511412. $2.6 \hat{x} \text{ V/m}$

8643511413. $24 \hat{x} \text{ V/m}$

8643511414. $-2.6 \hat{y} \text{ V/m}$

Question Number : 16 Question Id : 864351466 Question Type : MCQ Option Shuffling : Yes Is Question Mandatory : No

Correct Marks : 4 Wrong Marks : 1

ଶୂନ୍ୟରେ y - ଦିଗରେ 500 MHz ଆବୃତ୍ତିର ଗୋଟିଏ ସମତଳୀୟ ବିଦ୍ୟୁତ୍ ତୁମ୍ବକୀୟ ତରଙ୍ଗ ଗତି କରୁଛି । ଶୂନ୍ୟର ଏକ ନିର୍ଦ୍ଦିଷ୍ଟ

ବିନ୍ଦୁରେ ଏବଂ ସମୟରେ $\vec{B} = 8.0 \times 10^{-8} \hat{z} \text{ T}$ ଅଟେ । ଏହି ବିନ୍ଦୁରେ ବୈଦ୍ୟୁତିକ କ୍ଷେତ୍ରଚିତ୍ରର ମୂଲ୍ୟ ହେଉଛି :

(ଆଲୋକର ବେଗ = $3 \times 10^8 \text{ ms}^{-1}$)

(x , y ଏବଂ z ଦିଗରେ \hat{x} , \hat{y} ଏବଂ \hat{z} ଗୁଡ଼ିକ ହେଲା ଏକକ ସଦିଶ)

Options :

8643511411. $-24 \hat{x} \text{ V/m}$

8643511412. $2.6 \hat{x} \text{ V/m}$

8643511413. $24 \hat{x} \text{ V/m}$

8643511414. $-2.6 \hat{y}$ V/m

Question Number : 17 Question Id : 864351467 Question Type : MCQ Option Shuffling : Yes Is Question Mandatory : No

Correct Marks : 4 Wrong Marks : 1

A conducting bar of length L is free to slide on two parallel conducting rails as shown in the figure

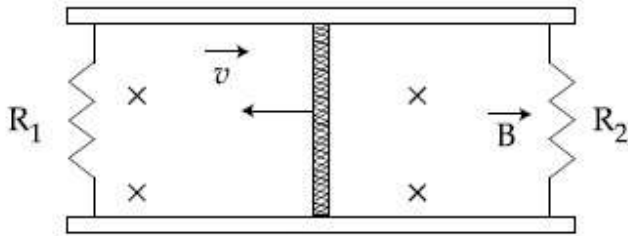

Two resistors R_1 and R_2 are connected across the ends of the rails. There is a uniform magnetic field \vec{B} pointing into the page. An external agent pulls the bar to the left at a constant speed v .

The correct statement about the directions of induced currents I_1 and I_2 flowing through R_1 and R_2 respectively is :

Options :

8643511415. I_1 is in anticlockwise direction and I_2 is in clockwise direction

8643511416. I_1 is in clockwise direction and I_2 is in anticlockwise direction

8643511417. Both I_1 and I_2 are in anticlockwise direction

8643511418. Both I_1 and I_2 are in clockwise direction

Question Number : 17 Question Id : 864351467 Question Type : MCQ Option Shuffling : Yes Is Question Mandatory : No

Correct Marks : 4 Wrong Marks : 1

ଚିତ୍ରରେ ଦର୍ଶାଯାଇଥିବା ଅନୁସାରେ, L ଦୈର୍ଘ୍ୟ ବିଶିଷ୍ଟ ବିଦ୍ୟୁତ୍ ପରିବାହୀ ଦୁଇଟି ସମାନ୍ତର ବିଦ୍ୟୁତ୍ ପରିବାହୀ ଧାରଣା ଉପରେ ମୁକ୍ତରେ ଗତି କରିବାକୁ ଛଡ଼ାଗଲା ।

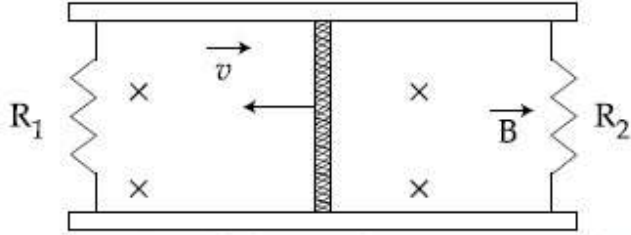

R_1 ଏବଂ R_2 ଦୁଇଟି ବିଦ୍ୟୁତ୍ ପ୍ରତିରୋଧ ଧାରଣା ଦୁଇଟିର ଦୁଇ ପ୍ରାନ୍ତରେ ସଂଯୋଗ କରାଗଲା । ଗୋଟିଏ ସମାନ (ଯୁନିଫର୍ମ) ବୃତ୍ତାକାର କ୍ଷେତ୍ର \vec{B} ପୃଷ୍ଠା ଆଡ଼କୁ ମୁହଁ କରି ରହିଅଛି । ଗୋଟିଏ ବାହ୍ୟ ଏଜେଣ୍ଟ ଦ୍ୱାରା ସ୍ଥିର ବେଗ v ରେ ବାମଦିଗକୁ ଚଳାଯାଇଛି ।

R_1 ଏବଂ R_2 ମଧ୍ୟ ଦେଇ ପ୍ରବାହିତ ପ୍ରେରିତ ବିଦ୍ୟୁତ୍ ସ୍ରୋତ I_1 ଏବଂ I_2 ର ଦିଗ ବିଷୟରେ ସଠିକ୍ ଉକ୍ତି ଅଟେ :

Options :

8643511415. I_1 ଘଣ୍ଟାର ବିପରୀତ ଦିଗରେ ଏବଂ I_2 ଘଣ୍ଟାର ଦିଗରେ

8643511416. I_1 ଘଣ୍ଟାର ଦିଗରେ ଏବଂ I_2 ଘଣ୍ଟାର ବିପରୀତ ଦିଗରେ

8643511417. ଉଭୟ I_1 ଏବଂ I_2 ଘଣ୍ଟାର ବିପରୀତ ଦିଗରେ

8643511418. ଉଭୟ I_1 ଏବଂ I_2 ଘଣ୍ଟାର ଦିଗରେ

Question Number : 18 Question Id : 864351468 Question Type : MCQ Option Shuffling : Yes Is Question Mandatory : No

Correct Marks : 4 Wrong Marks : 1

The pressure acting on a submarine is 3×10^5 Pa at a certain depth. If the depth is doubled, the percentage increase in the pressure acting on the submarine would be :

(Assume that atmospheric pressure is 1×10^5 Pa density of water is 10^3 kg m^{-3} , $g = 10 \text{ ms}^{-2}$)

Options :

8643511419. $\frac{5}{200}\%$

8643511420. $\frac{200}{5}\%$

8643511421. $\frac{200}{3}\%$

8643511422. $\frac{3}{200}\%$

Question Number : 18 Question Id : 864351468 Question Type : MCQ Option Shuffling : Yes Is Question Mandatory : No

Correct Marks : 4 Wrong Marks : 1

ନିର୍ଦ୍ଦିଷ୍ଟ ଗଭୀରତାରେ, ଏକ ବୁଡ଼ାଜାହାଜ ଉପରେ କାର୍ଯ୍ୟକାରୀ ଚାପ 3×10^5 Pa ଅଟେ । ଯଦି ଗଭୀରତାକୁ ଦୁଇଗୁଣ କରିଦିଆଯାଏ, ତେବେ ବୁଡ଼ାଜାହାଜଟି ଉପରେ ପଡୁଥିବା ଚାପରେ ହେଉଥିବା ଶତକଡ଼ା ବୃଦ୍ଧି ହେବ :
(ଧର ବାୟୁମଣ୍ଡଳୀୟ ଚାପ ଅଟେ 1×10^5 Pa, ଜଳର ସାନ୍ଦ୍ରତା ଅଟେ 10^3 kg m^{-3} ଏବଂ $g = 10 \text{ ms}^{-2}$)

Options :

8643511419. $\frac{5}{200}\%$

8643511420. $\frac{200}{5}\%$

8643511421. $\frac{200}{3}\%$

8643511422. $\frac{3}{200}\%$

Question Number : 19 Question Id : 864351469 Question Type : MCQ Option Shuffling : Yes Is Question Mandatory : No

Correct Marks : 4 Wrong Marks : 1

A conducting wire of length l , area of cross-section A and electric resistivity ρ is connected between the terminals of a battery. A potential difference V is developed between its ends, causing an electric current.

If the length of the wire of the same material is doubled and the area of cross-section is halved, the resultant current would be :

Options :

8643511423. $4 \frac{VA}{\rho l}$

8643511424. $\frac{1}{4} \frac{\rho l}{VA}$

8643511425. $\frac{1}{4} \frac{VA}{\rho l}$

8643511426. $\frac{3}{4} \frac{VA}{\rho l}$

Question Number : 19 Question Id : 864351469 Question Type : MCQ Option Shuffling : Yes Is Question Mandatory : No

Correct Marks : 4 Wrong Marks : 1

ଦୈର୍ଘ୍ୟ 'l' ପ୍ରସ୍ତୁତ କ୍ଷେତ୍ରଫଳ A ଏବଂ ବୈଦ୍ୟୁତିକ ପ୍ରତିରୋଧକତା ρ ବିଶିଷ୍ଟ ଗୋଟିଏ ପରିବାହୀ ତାରକୁ ବ୍ୟାଚେରୀର ଦୁଇମୁଣ୍ଡରେ ସଂଯୋଗ କରାଗଲା । ଉଭୟ ପ୍ରାନ୍ତ ମଧ୍ୟରେ ବିଭବ ପାର୍ଥକ୍ୟ V ଉତ୍ପନ୍ନ ହେଲା ଯାହା ବିଦ୍ୟୁତ୍ ସ୍ରୋତ ପ୍ରବାହ କଲା । ଯଦି ଏକା ପଦାର୍ଥରେ ତିଆରି ତାରଟିର ଦୈର୍ଘ୍ୟକୁ ଦୁଇଗୁଣ କରାଯାଏ ଏବଂ ପ୍ରସ୍ତୁତ କ୍ଷେତ୍ରଫଳକୁ ଅଧା କରାଯାଏ, ତେବେ ପରିଣାମୀ ବିଦ୍ୟୁତ୍ ସ୍ରୋତ ହେବ :

Options :

8643511423. $\frac{4}{\rho l} VA$

8643511424. $\frac{1}{4} \frac{\rho l}{VA}$

8643511425. $\frac{1}{4} \frac{VA}{\rho l}$

8643511426. $\frac{3}{4} \frac{VA}{\rho l}$

Question Number : 20 Question Id : 864351470 Question Type : MCQ Option Shuffling : Yes Is Question Mandatory : No

Correct Marks : 4 Wrong Marks : 1

One main scale division of a vernier callipers is 'a' cm and n^{th} division of the vernier scale coincide with $(n-1)^{\text{th}}$ division of the main scale. The least count of the callipers in mm is :

Options :

8643511427. $\left(\frac{n-1}{10n}\right)a$

8643511428. $\frac{10na}{(n-1)}$

8643511429. $\frac{10 a}{n}$

8643511430. $\frac{10 a}{(n - 1)}$

Question Number : 20 Question Id : 864351470 Question Type : MCQ Option Shuffling : Yes Is Question Mandatory : No

Correct Marks : 4 Wrong Marks : 1

ଏକ ଭର୍ନିଅର କାଲିପରସର ଏକ ମେନ୍‌ସେଲ୍ ଭାଗ a cm ଅଟେ ଏବଂ ଭର୍ନିଅର ସ୍କେଲର n^{th} ଡମ ଭାଗ ମୁଖ୍ୟ ସ୍କେଲ (ମେନ୍‌ସେଲ୍) ର $(n-1)^{\text{th}}$ ଭାଗ ସହ ମିଳିତ ହୋଇଥାଏ । କାଲିପରସର ସ୍ୱତନ୍ତ୍ର ମାପ (ଲିଷ୍ଟ କାଉଣ୍ଟ) ମିଲିମିଟରରେ ଅଟେ :

Options :

8643511427. $\left(\frac{n - 1}{10 n}\right)a$

8643511428. $\frac{10 na}{(n - 1)}$

8643511429. $\frac{10 a}{n}$

8643511430. $\frac{10 a}{(n - 1)}$

Physics Section B

Section Id :	86435132
Section Number :	2
Section type :	Online
Mandatory or Optional :	Mandatory
Number of Questions :	10
Number of Questions to be attempted :	5
Section Marks :	20
Mark As Answered Required? :	Yes
Sub-Section Number :	1
Sub-Section Id :	86435132
Question Shuffling Allowed :	Yes

Question Number : 21 Question Id : 864351471 Question Type : SA

Correct Marks : 4 Wrong Marks : 0

A sinusoidal voltage of peak value 250 V is applied to a series LCR circuit, in which $R=8\ \Omega$, $L=24\ \text{mH}$ and $C=60\ \mu\text{F}$. The value of power dissipated at resonant condition is 'x' kW.

The value of x to the nearest integer is _____.

Response Type : Numeric

Evaluation Required For SA : Yes

Show Word Count : Yes

Answers Type : Equal

Text Areas : PlainText

Possible Answers :

100

Question Number : 21 Question Id : 864351471 Question Type : SA

Correct Marks : 4 Wrong Marks : 0

ସର୍ବୋଚ୍ଚ ମୂଲ୍ୟ 250 V ର ସାଇନୋସାଇଡାଲ୍ ବିଦ୍ୟୁତ୍ ବିଭବକୁ ଏକ ଶ୍ରେଣୀରେ ସଂଯୁକ୍ତ LCR ପରିପଥରେ ପ୍ରୟୋଗ କରାଯାଇଛି, ଯେଉଁଠାରେ $R=8\ \Omega$, $L=24\ \text{mH}$ ଏବଂ $C=60\ \mu\text{F}$ ଅଟେ । ଅନୁନାଦିତ ସ୍ଥିତିରେ ଅପଚୟ ହେଉଥିବା ଶକ୍ତିର ମୂଲ୍ୟ 'x' kW ଅଟେ । ନିକଟତମ ପୂର୍ଣ୍ଣସଂଖ୍ୟାରେ x ର ମୂଲ୍ୟ ଅଟେ _____ ।

Response Type : Numeric

Evaluation Required For SA : Yes

Show Word Count : Yes

Answers Type : Equal

Text Areas : PlainText

Possible Answers :

100

Question Number : 22 Question Id : 864351472 Question Type : SA

Correct Marks : 4 Wrong Marks : 0

Consider a frame that is made up of two thin massless rods AB and AC as shown in the figure. A vertical force \vec{P} of magnitude 100 N is applied at point A of the frame.

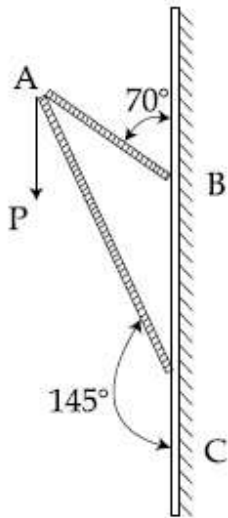

Suppose the force is \vec{P} resolved parallel to the arms AB and AC of the frame.

The magnitude of the resolved component along the arm AC is x N.

The value of x , to the nearest integer, is _____.

[Given : $\sin(35^\circ) = 0.573$, $\cos(35^\circ) = 0.819$

$\sin(110^\circ) = 0.939$, $\cos(110^\circ) = -0.342$]

Response Type : Numeric

Evaluation Required For SA : Yes

Show Word Count : Yes

Answers Type : Equal

Text Areas : PlainText

Possible Answers :

100

Question Number : 22 **Question Id :** 864351472 **Question Type :** SA

Correct Marks : 4 **Wrong Marks :** 0

ଚିତ୍ରରେ ଦର୍ଶାଯାଇଥିବା ଅନୁସାରେ ଗୋଟିଏ ପ୍ରେମକୁ ବିଚାର କର ଯାହା ଦୁଇଟି ପତଳା ବସ୍ତୁତ୍ୱହୀନ ରତ୍ AB ଏବଂ AC ଦ୍ୱାରା ଗଠିତ । ପ୍ରେମର A ବିନ୍ଦୁରେ 100 N ପରିମାଣର ଏକ ଭୂଲମ୍ବ ବଳ \vec{P} କୁ ପ୍ରୟୋଗ କରାଯାଇଛି ।

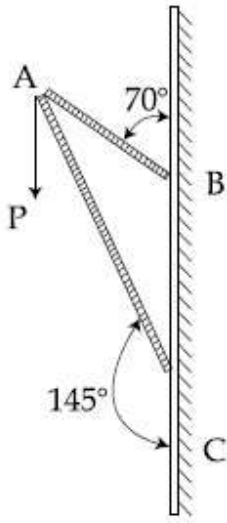

ମନେକର ବଳ \vec{P} କୁ AB ଏବଂ AC ବାହୁ ସହ ସମାନ୍ତର ଦିଗରେ ପୃଥକ୍ (ରିଜଲଭ୍) କରାଗଲା । AC ବାହୁ ଦେଇ ବଳର ଅଂଶର ପରିମାଣ xN ଅଟେ । ନିକଟତମ ପୂର୍ଣ୍ଣସଂଖ୍ୟାରେ x ର ମୂଲ୍ୟ ହେବ _____ ।

[ଦତ୍ତ : $\sin(35^\circ) = 0.573$, $\cos(35^\circ) = 0.819$

$\sin(110^\circ) = 0.939$, $\cos(110^\circ) = -0.342$]

Response Type : Numeric

Evaluation Required For SA : Yes

Show Word Count : Yes

Answers Type : Equal

Text Areas : PlainText

Possible Answers :

100

Question Number : 23 **Question Id :** 864351473 **Question Type :** SA

Correct Marks : 4 **Wrong Marks :** 0

The first three spectral lines of H-atom in the Balmer series are given $\lambda_1, \lambda_2, \lambda_3$ considering the

Bohr atomic model, the wave lengths of first and third spectral lines $\left(\frac{\lambda_1}{\lambda_3}\right)$ are related by a

factor of approximately ' x ' $\times 10^{-1}$.

The value of x , to the nearest integer, is _____.

Response Type : Numeric

Evaluation Required For SA : Yes

Show Word Count : Yes

Answers Type : Equal

Text Areas : PlainText

Possible Answers :

100

Question Number : 23 Question Id : 864351473 Question Type : SA

Correct Marks : 4 Wrong Marks : 0

ବୋହରଙ୍କ ପରମାଣୁ ମଡେଲକୁ ବିଚାରକୁ ନେଇ ବାଲମର ଶ୍ରେଣୀର ପ୍ରଥମ ତିନୋଟି ବର୍ଣ୍ଣାଳୀ ରେଖାଗୁଡ଼ିକୁ λ_1, λ_2 ଏବଂ λ_3 ଦ୍ୱାରା ଦର୍ଶାଯାଇଛି । ପ୍ରଥମ ଏବଂ ଦ୍ୱିତୀୟ ବର୍ଣ୍ଣାଳୀ ରେଖାର ଅନୁପାତ $\left(\frac{\lambda_1}{\lambda_3}\right)$ କୁ ଆନୁମାନିକ ଭାବେ ' x ' $\times 10^{-1}$ ଦ୍ୱାରା ଦେଖାଯାଇଛି । ନିକଟତମ ପୂର୍ଣ୍ଣସଂଖ୍ୟାରେ ' x ' ର ମୂଲ୍ୟ ହେବ _____ ।

Response Type : Numeric

Evaluation Required For SA : Yes

Show Word Count : Yes

Answers Type : Equal

Text Areas : PlainText

Possible Answers :

100

Question Number : 24 Question Id : 864351474 Question Type : SA

Correct Marks : 4 Wrong Marks : 0

The value of power dissipated across the zener diode ($V_z = 15$ V) connected in the circuit as shown in the figure is $x \times 10^{-1}$ watt.

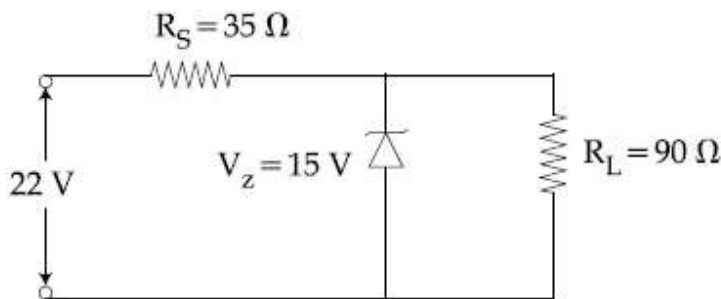

The value of x , to the nearest integer, is _____.

Response Type : Numeric

Evaluation Required For SA : Yes

Show Word Count : Yes

Answers Type : Equal

Text Areas : PlainText

Possible Answers :

100

Question Number : 24 Question Id : 864351474 Question Type : SA

Correct Marks : 4 Wrong Marks : 0

ଚିତ୍ରରେ ଦର୍ଶାଯାଇଥିବା ବିଦ୍ୟୁତ୍ ପରିପଥରେ ସଂଯୁକ୍ତ ଜନର ଡାଇଓଡ୍ ($V_z = 15 \text{ V}$) ରେ ହେଉଥିବା ଶକ୍ତି ଅପଚୟ ଅଟେ $x \times 10^{-1}$ ୱାଟ୍ ।

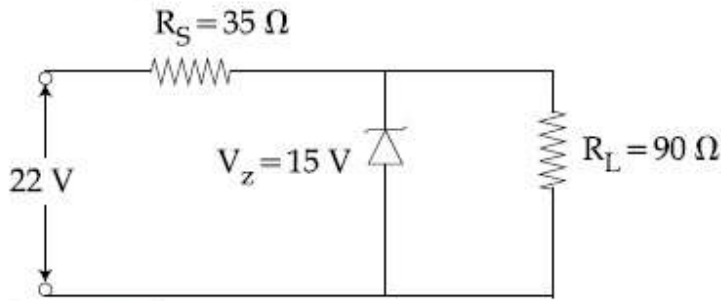

ନିକଟତମ ପୂର୍ଣ୍ଣସଂଖ୍ୟାରେ x ର ମୂଲ୍ୟ ଅଟେ _____ ।

Response Type : Numeric

Evaluation Required For SA : Yes

Show Word Count : Yes

Answers Type : Equal

Text Areas : PlainText

Possible Answers :

100

Question Number : 25 **Question Id :** 864351475 **Question Type :** SA

Correct Marks : 4 **Wrong Marks :** 0

A ball of mass 10 kg moving with a velocity $10\sqrt{3} \text{ m s}^{-1}$ along X-axis, hits another ball of mass 20 kg which is at rest. After collision, the first ball comes to rest and the second one disintegrates into two equal pieces. One of the pieces starts moving along Y-axis at a speed of 10 m/s. The second piece starts moving at a speed of 20 m/s at an angle θ (degree) with respect to the X-axis.

The configuration of pieces after collision is shown in the figure.

The value of θ to the nearest integer is _____.

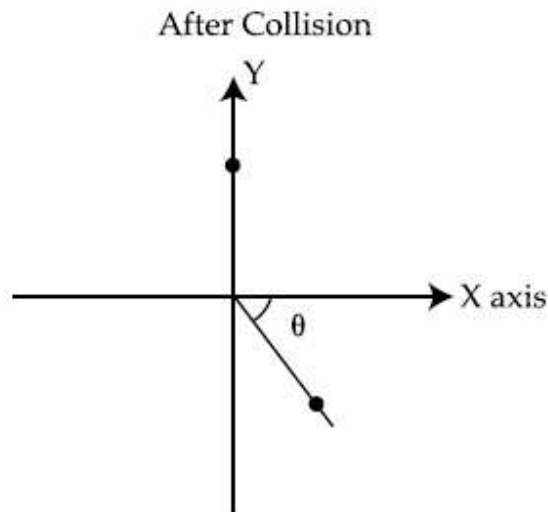

Response Type : Numeric

Evaluation Required For SA : Yes

Show Word Count : Yes

Answers Type : Equal

Text Areas : PlainText

Possible Answers :

100

Question Number : 25 Question Id : 864351475 Question Type : SA

Correct Marks : 4 Wrong Marks : 0

ଗୋଟିଏ 10 kg ବସ୍ତୁ ବିଶିଷ୍ଟ ବଲ୍ $10\sqrt{3}\text{ m s}^{-1}$ ବେଗରେ X -ଅକ୍ଷ ଦେଇ ଗତିକରି ଛିର ଅବସ୍ଥାରେ ଥିବା 20 kg ବସ୍ତୁ ବିଶିଷ୍ଟ ଅନ୍ୟ ଏକ ବଲ୍‌କୁ ଧକ୍କା ଦେଲା । ଧକ୍କା ପରେ, ପ୍ରଥମ ବଲ୍‌ଟି ଛିର ଅବସ୍ଥାକୁ ଫେରି ଆସିଲା ଏବଂ ଦ୍ୱିତୀୟ ବଲ୍‌ଟି ସମାନ୍ତ ଦୁଇଖଣ୍ଡରେ ବିଭକ୍ତ ହୋଇଗଲା । ଏହି ଖଣ୍ଡ ମଧ୍ୟରୁ ଗୋଟିଏ 10 m/s ବେଗରେ Y -ଅକ୍ଷ ଦେଇ ଗତିକଲା । ଦ୍ୱିତୀୟ ଖଣ୍ଡଟି 20 m/s ବେଗରେ X ଅକ୍ଷ ସହ θ କୋଣ ଉତ୍ପନ୍ନ କରି ଗତି କରିବାକୁ ଆରମ୍ଭ କଲା ।

(ବିଘଟନ ପ୍ରକ୍ରିୟା ଚିତ୍ରରେ ଦର୍ଶାଯାଇଛି)

θ ର ମୂଲ୍ୟ ନିକଟତମ ପୂର୍ଣ୍ଣସଂଖ୍ୟାରେ ଅଟେ _____ ।

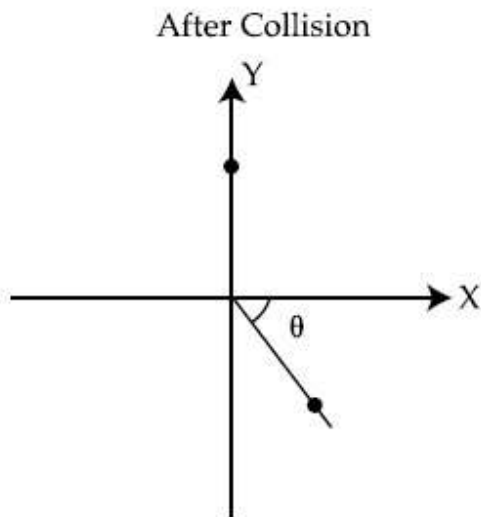

Response Type : Numeric

Evaluation Required For SA : Yes

Show Word Count : Yes

Answers Type : Equal

Text Areas : PlainText

Possible Answers :

100

Question Number : 26 Question Id : 864351476 Question Type : SA

Correct Marks : 4 Wrong Marks : 0

Consider a 20 kg uniform circular disk of radius 0.2 m. It is pin supported at its center and is at rest initially. The disk is acted upon by a constant force $F = 20 \text{ N}$ through a massless string wrapped around its periphery as shown in the figure.

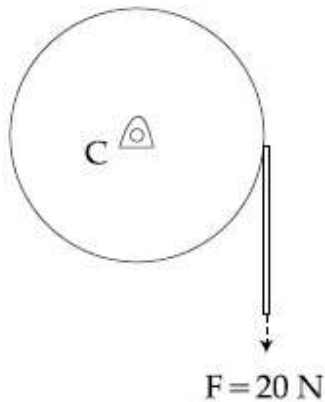

Suppose the disk makes n number of revolutions to attain an angular speed of 50 rad s^{-1} . The value of n , to the nearest integer, is _____.

[Given : In one complete revolution, the disk rotates by 6.28 rad]

Response Type : Numeric

Evaluation Required For SA : Yes

Show Word Count : Yes

Answers Type : Equal

Text Areas : PlainText

Possible Answers :

100

Question Number : 26 **Question Id :** 864351476 **Question Type :** SA

Correct Marks : 4 **Wrong Marks :** 0

0.2 m ବ୍ୟାସାର୍ଦ୍ଧ ବିଶିଷ୍ଟ 20 କି.ଗ୍ରାମ ଏକ ସରଳ ବୃତ୍ତାକାର ଡିସ୍କ(ଫାଳ)କୁ ବିଚାର କର । ଏହା ପ୍ରାରମ୍ଭିକ ଭାବେ ଛିର ଅବସ୍ଥାରେ ଏକ ପିନ୍ ମୁନରେ (ଡିସ୍କର କେନ୍ଦ୍ର) ଅବସ୍ଥିତ । ଏକ ବସ୍ତୁତ୍ୱବିହୀନ ସୂତା ଦ୍ୱାରା ଗୁଡ଼ାଯାଇଥିବା ଡିସ୍କ ଉପରେ ଏହି ସୂତା ମଧ୍ୟ ବେଳ ଏକ ଛିରବଳ $F = 20 \text{ N}$ ପ୍ରୟୋଗ କରାଯାଇଛି । (ଚିତ୍ରରେ ଦର୍ଶାଯାଇଛି)

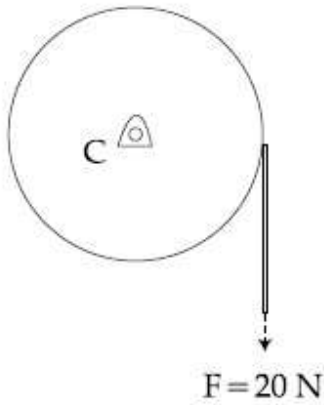

ମନେକର ଡିସ୍କଟି n ଥର ଘୂର୍ଣ୍ଣନ ପରେ 50 rad s^{-1} କୌଣସିକ ବେଗରେ ପହଞ୍ଚିଛି ।
 n ର ମୂଲ୍ୟ ଅଟେ _____ ।
 (ଗୋଟିଏ ସଂପୂର୍ଣ୍ଣ ଘୂର୍ଣ୍ଣନରେ ଡିସ୍କ ଘୂରେ 6.28 rad)

Response Type : Numeric

Evaluation Required For SA : Yes

Show Word Count : Yes

Answers Type : Equal

Text Areas : PlainText

Possible Answers :

100

Question Number : 27 **Question Id :** 864351477 **Question Type :** SA

Correct Marks : 4 **Wrong Marks :** 0

In the logic circuit shown in the figure, if input A and B are 0 to 1 respectively, the output at Y would be 'x'.

The value of x is _____.

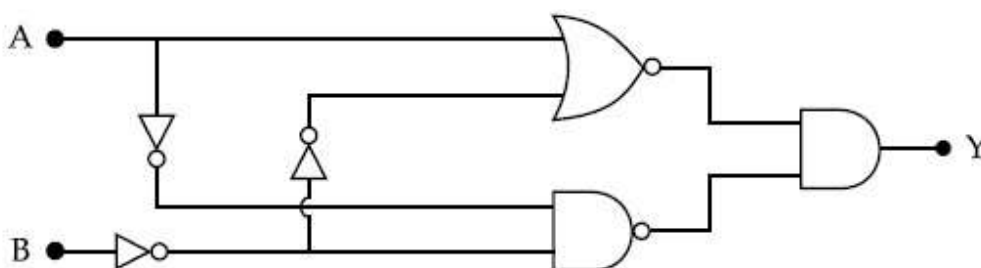

Response Type : Numeric

Evaluation Required For SA : Yes

Show Word Count : Yes

Answers Type : Equal

Text Areas : PlainText

Possible Answers :

100

Question Number : 27 Question Id : 864351477 Question Type : SA

Correct Marks : 4 Wrong Marks : 0

ଚିତ୍ରରେ ଦର୍ଶାଯାଇଥିବା ଲଜିକ୍ ପରିପଥଟିରେ, ଯଦି A ଏବଂ B ନିବେଶ (ଇନପୁଟ୍) ଯଥାକ୍ରମେ 0 ଓ 1 ଏବଂ Y ଠାରେ ବର୍ତ୍ତମାନ ହେବ 'x' ।

x ର ମୂଲ୍ୟ ହେବ _____ ।

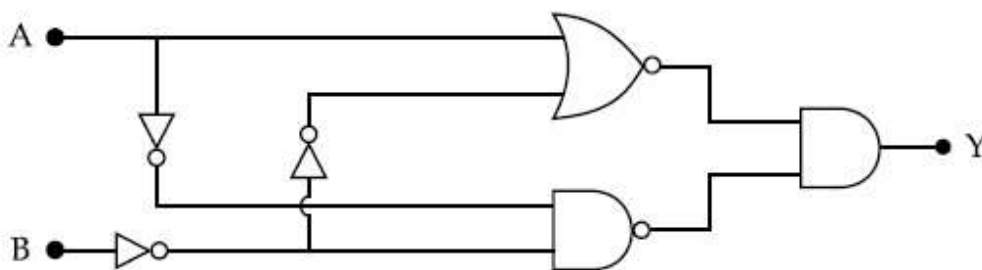

Response Type : Numeric

Evaluation Required For SA : Yes

Show Word Count : Yes

Answers Type : Equal

Text Areas : PlainText

Possible Answers :

100

Question Number : 28 Question Id : 864351478 Question Type : SA

Correct Marks : 4 Wrong Marks : 0

In the figure given, the electric current flowing through the 5 k Ω resistor is 'x' mA.

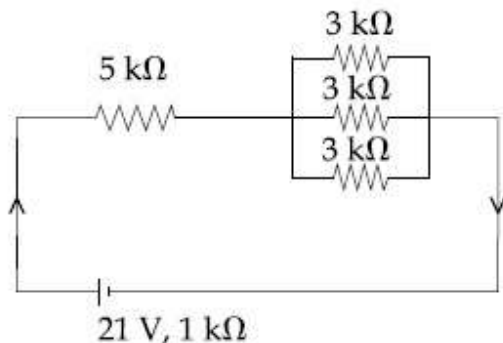

The value of x to the nearest integer is _____.

Response Type : Numeric

Evaluation Required For SA : Yes

Show Word Count : Yes

Answers Type : Equal

Text Areas : PlainText

Possible Answers :

100

Question Number : 28 Question Id : 864351478 Question Type : SA

Correct Marks : 4 Wrong Marks : 0

ଦଳ ଚିତ୍ରରେ, $5\text{ k}\Omega$ ପ୍ରତିରୋଧ ମଧ୍ୟବେଳେ ପ୍ରବାହିତ ବିଦ୍ୟୁତ୍ ସ୍ରୋତ ଅଟେ ' x ' mA ।

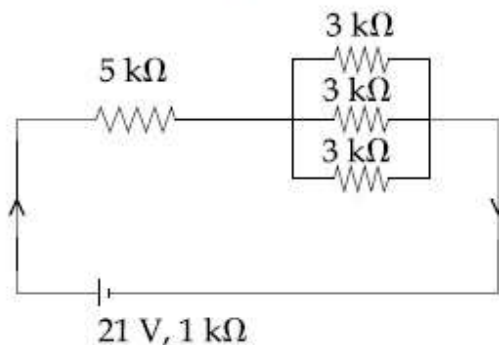

ନିକଟତମ ପୂର୍ଣ୍ଣସଂଖ୍ୟାରେ x ର ମୂଲ୍ୟ ହେବ _____ ।

Response Type : Numeric

Evaluation Required For SA : Yes

Show Word Count : Yes

Answers Type : Equal

Text Areas : PlainText

Possible Answers :

100

Question Number : 29 Question Id : 864351479 Question Type : SA

Correct Marks : 4 Wrong Marks : 0

A fringe width of 6 mm was produced for two slits separated by 1 mm apart. The screen is placed 10 m away. The wavelength of light used is ' x ' nm.

The value of ' x ' to the nearest integer is _____.

Response Type : Numeric

Evaluation Required For SA : Yes

Show Word Count : Yes

Answers Type : Equal

Text Areas : PlainText

Possible Answers :

100

Question Number : 29 Question Id : 864351479 Question Type : SA

Correct Marks : 4 Wrong Marks : 0

1 mm ଦୂରତାରେ ଥିବା ଦୁଇଟି ଛିଦ୍ର (ସିର) ପାଇଁ ଉତ୍ତର ପ୍ରିଞ୍ଚ ପ୍ରସ୍ଥ 6 mm ଅଟେ । ପରଦାଟି 10 m ଦୂରତାରେ ରଖାଯାଇଛି । ବ୍ୟବହୃତ ଆଲୋକଟିର ତରଙ୍ଗ ଦୈର୍ଘ୍ୟ ଅଟେ 'x' nm ।

ନିକଟତମ ପୂର୍ଣ୍ଣସଂଖ୍ୟାରେ 'x' ର ମୂଲ୍ୟ ହେବ _____ ।

Response Type : Numeric

Evaluation Required For SA : Yes

Show Word Count : Yes

Answers Type : Equal

Text Areas : PlainText

Possible Answers :

100

Question Number : 30 **Question Id :** 864351480 **Question Type :** SA

Correct Marks : 4 **Wrong Marks :** 0

The resistance $R = \frac{V}{I}$, where $V = (50 \pm 2)V$ and $I = (20 \pm 0.2)A$. The percentage error in R is

'x' %.

The value of 'x' to the nearest integer is _____.

Response Type : Numeric

Evaluation Required For SA : Yes

Show Word Count : Yes

Answers Type : Equal

Text Areas : PlainText

Possible Answers :

100

Question Number : 30 **Question Id :** 864351480 **Question Type :** SA

Correct Marks : 4 **Wrong Marks :** 0

ବିଦ୍ୟୁତ୍ ପ୍ରତିରୋଧ $R = \frac{V}{I}$, ଯେଉଁଠାରେ $V = (50 \pm 2)V$ ଏବଂ $I = (20 \pm 0.2)A$ । R ରେ ରହୁଥିବା ଶତକଡ଼ା ତ୍ରୁଟି

ଅଟେ x% । ନିକଟତମ ପୂର୍ଣ୍ଣସଂଖ୍ୟାରେ 'x' ର ମୂଲ୍ୟ ଅଟେ _____ ।

Response Type : Numeric

Evaluation Required For SA : Yes

Show Word Count : Yes

Answers Type : Equal

Text Areas : PlainText

Possible Answers :

100

Section Id :	86435133
Section Number :	3
Section type :	Online
Mandatory or Optional :	Mandatory
Number of Questions :	20
Number of Questions to be attempted :	20
Section Marks :	80
Mark As Answered Required? :	Yes
Sub-Section Number :	1
Sub-Section Id :	86435133
Question Shuffling Allowed :	Yes

Question Number : 31 Question Id : 864351481 Question Type : MCQ Option Shuffling : Yes Is Question Mandatory : No

Correct Marks : 4 Wrong Marks : 1

Given below are two statements : one is labelled as Assertion A and the other is labelled as Reason R :

Assertion A : The H – O – H bond angle in water molecule is 104.5° .

Reason R : The lone pair - lone pair repulsion of electrons is higher than the bond pair - bond pair repulsion.

In the light of the above statements, choose the correct answer from the options given below :

Options :

8643511441. Both A and R are true, and R is the correct explanation of A

8643511442. Both A and R are true, but R is not the correct explanation of A

8643511443. A is true but R is false

8643511444. A is false but R is true

Question Number : 31 Question Id : 864351481 Question Type : MCQ Option Shuffling : Yes Is Question Mandatory : No

Correct Marks : 4 Wrong Marks : 1

ନିମ୍ନରେ ଦୁଇଟି ଉକ୍ତି ଦିଆଯାଇଛି : ଗୋଟିଏ ଦୃଢ଼ୋକ୍ତି A ଏବଂ ଅନ୍ୟଟି କାରଣ R ।

ଦୃଢ଼ୋକ୍ତି A : ଜଳର H – O – H ବନ୍ଧ କୋଣ 104.5° ଅଟେ ।

କାରଣ R : ଏକାକୀ ଇଲେକ୍ଟ୍ରନ୍ ଯୋଡ଼ା - ଏକାକୀ ଇଲେକ୍ଟ୍ରନ୍ ଯୋଡ଼ା ବିକର୍ଷଣ ବନ୍ଧଯୋଡ଼ା - ବନ୍ଧଯୋଡ଼ା ବିକର୍ଷଣ ଠାରୁ ଅଧିକ ।

ଉପରୋକ୍ତ ଉକ୍ତି ଅନୁସାରେ, ନିମ୍ନଲିଖିତ ବିକଳ୍ପ ମଧ୍ୟରୁ ସଠିକ୍ ଉତ୍ତରଟି ବାଛି ।

Options :

8643511441. ଉଭୟ A ଏବଂ R ସତ୍ୟ ଅଟେ ଏବଂ A ର ସଠିକ୍ ବ୍ୟାଖ୍ୟା ହେଉଛି R ।

8643511442. ଉଭୟ A ଏବଂ R ସତ୍ୟ ଅଟେ କିନ୍ତୁ A ର ସଠିକ୍ ବ୍ୟାଖ୍ୟା R ନୁହେଁ ।

8643511443. A ସତ୍ୟ କିନ୍ତୁ R ମିଥ୍ୟା ଅଟେ ।

8643511444. A ମିଥ୍ୟା କିନ୍ତୁ R ସତ୍ୟ ଅଟେ ।

Question Number : 32 Question Id : 864351482 Question Type : MCQ Option Shuffling : Yes Is Question Mandatory : No

Correct Marks : 4 Wrong Marks : 1

Match List - I with List - II :

List - I

Industrial process

(a) Haber's process

(b) Ostwald's process

(c) Contact process

(d) Hall-Heroult process

List - II

Application

(i) HNO_3 synthesis

(ii) Aluminium extraction

(iii) NH_3 synthesis

(iv) H_2SO_4 synthesis

Choose the correct answer from the options given below :

Options :

8643511445. (a)-(iv), (b)-(i), (c)-(ii), (d)-(iii)

8643511446. (a)-(iii), (b)-(i), (c)-(iv), (d)-(ii)

8643511447. (a)-(ii), (b)-(iii), (c)-(iv), (d)-(i)

8643511448. (a)-(iii), (b)-(iv), (c)-(i), (d)-(ii)

Question Number : 32 Question Id : 864351482 Question Type : MCQ Option Shuffling : Yes Is Question Mandatory : No

Correct Marks : 4 Wrong Marks : 1

ତାଲିକା - II ସହିତ ତାଲିକା - I କୁ ମିଳାଅ :

ତାଲିକା - I	ତାଲିକା - II
ଶିଳ୍ପ ପ୍ରଣାଳୀ	ପ୍ରୟୋଗ
(a) ହାବରକ ପ୍ରଣାଳୀ	(i) HNO_3 ସଂଶ୍ଳେଷଣ
(b) ଅଷ୍ଟାଲୁ ପ୍ରଣାଳୀ	(ii) ଆଲୁମିନିୟମ୍ ନିଷ୍କାସନ
(c) କଞ୍ଚାକ ପ୍ରଣାଳୀ	(iii) NH_3 ସଂଶ୍ଳେଷଣ
(d) ହଲ-ହେରୋଲ୍ ପ୍ରଣାଳୀ	(iv) H_2SO_4 ସଂଶ୍ଳେଷଣ

ନିମ୍ନଲିଖିତ ମଧ୍ୟରୁ ସଠିକ୍ ଉତ୍ତରଟି ବାଛି :

Options :

8643511445. (a)-(iv), (b)-(i), (c)-(ii), (d)-(iii)

8643511446. (a)-(iii), (b)-(i), (c)-(iv), (d)-(ii)

8643511447. (a)-(ii), (b)-(iii), (c)-(iv), (d)-(i)

8643511448. (a)-(iii), (b)-(iv), (c)-(i), (d)-(ii)

Question Number : 33 Question Id : 864351483 Question Type : MCQ Option Shuffling : Yes Is Question Mandatory : No

Correct Marks : 4 Wrong Marks : 1

A group 15 element, which is a metal and forms a hydride with strongest reducing power among group 15 hydrides. The element is :

Options :

8643511449. Bi

8643511450. P

8643511451. As

8643511452. Sb

Question Number : 33 Question Id : 864351483 Question Type : MCQ Option Shuffling : Yes Is Question Mandatory : No

Correct Marks : 4 Wrong Marks : 1

ଗ୍ରୁପ୍ 15 ରେ ଏକ ମୌଳିକ ଯିଏକି ଏକ ଉପଧାରୁ ଏବଂ ଉଚ୍ଚ ମୌଳିକର ହାଇଡ୍ରାଇଡ଼ିର ବିଜାରଣ କ୍ଷମତା ସେହି ଗ୍ରୁପ୍‌ର ଅନ୍ୟ ହାଇଡ୍ରାଇଡ଼ିଗୁଡ଼ିକର ବିଜାରଣ କ୍ଷମତା ଠାରୁ ସର୍ବାଧିକ ଶକ୍ତିଶାଳୀ ।

ମୌଳିକଟି ହେଉଛି :

Options :

8643511449. Bi

8643511450. P

8643511451. As

8643511452. Sb

Question Number : 34 Question Id : 864351484 Question Type : MCQ Option Shuffling : Yes Is Question Mandatory : No

Correct Marks : 4 Wrong Marks : 1

The process that involves the removal of sulphur from the ores is :

Options :

8643511453. Refining

8643511454. Roasting

8643511455. Smelting

8643511456. Leaching

Question Number : 34 Question Id : 864351484 Question Type : MCQ Option Shuffling : Yes Is Question Mandatory : No

Correct Marks : 4 Wrong Marks : 1

ଧାତୁପିଣ୍ଡରୁ ସଲଫର ନିଷ୍କାସନ ପ୍ରଣାଳୀଟି ହେଉଛି :

Options :

8643511453. ବିଶୁଦ୍ଧିକରଣ

8643511454. ରୋଷ୍ଟିଙ୍ଗ

8643511455. ବିଗଳନ

8643511456. ନିଷ୍କାଳନ

Question Number : 35 Question Id : 864351485 Question Type : MCQ Option Shuffling : Yes Is Question Mandatory : No

Correct Marks : 4 Wrong Marks : 1

Given below are two statements :

Statement I : H_2O_2 can act as both oxidising and reducing agent in basic medium.

Statement II : In the hydrogen economy, the energy is transmitted in the form of dihydrogen.

In the light of the above statements, choose the correct answer from the options given below :

Options :

8643511457. Both statement I and statement II are true

8643511458. Both statement I and statement II are false

8643511459. Statement I is true but statement II is false

8643511460. Statement I is false but statement II is true

Question Number : 35 Question Id : 864351485 Question Type : MCQ Option Shuffling : Yes Is Question Mandatory : No

Correct Marks : 4 Wrong Marks : 1

ନିମ୍ନରେ ଦୁଇଟି ଉକ୍ତି ଦିଆଯାଇଛି :

ଉକ୍ତି I : କ୍ଷାରୀୟ ମାଧ୍ୟମରେ H_2O_2 ଉଭୟ ଜାରକ, ଏବଂ ବିଜାରକ ଭାବେ କାର୍ଯ୍ୟକରେ ।

ଉକ୍ତି II : ହାଇଡ୍ରୋଜେନ୍ ମିଟବ୍ୟାୟିତା ଅନୁସାରେ, ଏହାର ଶକ୍ତି ଡାଇହାଇଡ୍ରୋଜେନ୍ ରୂପରେ ସଂଚାରିତ ହୁଏ ।

ଉପରୋକ୍ତ ଉକ୍ତି ଅନୁସାରେ, ନିମ୍ନଲିଖିତ ବିକଳ୍ପ ମଧ୍ୟରୁ ସଠିକ୍ ଉତ୍ତରଟିକୁ ବାଛି :

Options :

8643511457. ଉଭୟ ଉକ୍ତି I ଏବଂ ଉକ୍ତି II ସତ୍ୟ ଅଟେ ।

8643511458. ଉଭୟ ଉକ୍ତି I ଏବଂ ଉକ୍ତି II ମିଥ୍ୟା ଅଟେ ।

8643511459. ଉକ୍ତି I ସତ୍ୟ କିନ୍ତୁ ଉକ୍ତି II ମିଥ୍ୟା ଅଟେ ।

8643511460. ଉକ୍ତି I ମିଥ୍ୟା କିନ୍ତୁ ଉକ୍ତି II ସତ୍ୟ ଅଟେ ।

Question Number : 36 Question Id : 864351486 Question Type : MCQ Option Shuffling : Yes Is Question Mandatory : No

Correct Marks : 4 Wrong Marks : 1

Given below are two statements :

Statement I : Both $\text{CaCl}_2 \cdot 6\text{H}_2\text{O}$ and $\text{MgCl}_2 \cdot 8\text{H}_2\text{O}$ undergo dehydration on heating.

Statement II : BeO is amphoteric whereas the oxides of other elements in the same group are acidic.

In the light of the above statements, choose the correct answer from the options given below :

Options :

8643511461. Both statement I and statement II are true

8643511462. Both statement I and statement II are false

8643511463. Statement I is true but statement II is false

8643511464. Statement I is false but statement II is true

Question Number : 36 Question Id : 864351486 Question Type : MCQ Option Shuffling : Yes Is Question Mandatory : No

Correct Marks : 4 Wrong Marks : 1

ନିମ୍ନରେ ଦୁଇଟି ଉକ୍ତି ଦିଆଯାଇଛି :

ଉକ୍ତି I : ଉଭୟ $\text{CaCl}_2 \cdot 6\text{H}_2\text{O}$ ଏବଂ $\text{MgCl}_2 \cdot 8\text{H}_2\text{O}$ ଗରମ କଲେ ନିର୍ଜଳୀକରଣ ହୋଇଥାନ୍ତି ।

ଉକ୍ତି II : BeO ଉଦ୍ଭୟଧର୍ମୀ ଯେଉଁଠିକି ସମାନ ଗୁଣରେ ଥିବା ଅନ୍ୟ ମୌଳିକର ଅକ୍ସାଇଡ୍ ଗୁଡ଼ିକ ଅମ୍ଳୀୟ ଅଟନ୍ତି ।

ଉପରୋକ୍ତ ଉକ୍ତି ଅନୁସାରେ, ନିମ୍ନଲିଖିତ ବିକଳ୍ପ ମଧ୍ୟରୁ ସଠିକ୍ ଉତ୍ତରଟିକୁ ବାଛି :

Options :

8643511461. ଉକ୍ତି I ଏବଂ ଉକ୍ତି II ଉଭୟ ସତ୍ୟ ଅଟେ ।

8643511462. ଉକ୍ତି I ଏବଂ ଉକ୍ତି II ଉଭୟ ମିଥ୍ୟା ଅଟେ ।

8643511463. ଉକ୍ତି I ସତ୍ୟ କିନ୍ତୁ ଉକ୍ତି II ମିଥ୍ୟା ଅଟେ ।

8643511464. ଉକ୍ତି I ମିଥ୍ୟା କିନ୍ତୁ ଉକ୍ତି II ସତ୍ୟ ଅଟେ ।

Question Number : 37 Question Id : 864351487 Question Type : MCQ Option Shuffling : Yes Is Question Mandatory : No

Correct Marks : 4 Wrong Marks : 1

Match List - I with List - II :

List - I		List - II	
Name of oxo acid		Oxidation state of 'P'	
(a) Hypophosphorous acid	(i)	+ 5	
(b) Orthophosphoric acid	(ii)	+ 4	
(c) Hypophosphoric acid	(iii)	+ 3	
(d) Orthophosphorous acid	(iv)	+ 2	
	(v)	+ 1	

Choose the correct answer from the options given below :

Options :

8643511465. (a)-(v), (b)-(iv), (c)-(ii), (d)-(iii)

8643511466. (a)-(iv), (b)-(i), (c)-(ii), (d)-(iii)

8643511467. (a)-(iv), (b)-(v), (c)-(ii), (d)-(iii)

8643511468. (a)-(v), (b)-(i), (c)-(ii), (d)-(iii)

Question Number : 37 Question Id : 864351487 Question Type : MCQ Option Shuffling : Yes Is Question Mandatory : No

Correct Marks : 4 Wrong Marks : 1

ତାଲିକା - I କୁ ତାଲିକା - II ସହିତ ମିଳାଅ :

ତାଲିକା - I		ତାଲିକା - II	
ଅକ୍ସୋଅମ୍ଳର ନାମ		ଫସଫରସର ଜାରଣ ଅବସ୍ଥା	
(a) ହାଇପୋ ଫସଫରସ ଅମ୍ଳ	(i)	+ 5	
(b) ଅର୍ଥୋ ଫସଫରିକ୍ ଅମ୍ଳ	(ii)	+ 4	
(c) ହାଇପୋ ଫସଫରିକ୍ ଅମ୍ଳ	(iii)	+ 3	
(d) ଅର୍ଥୋ ଫସଫରସ ଅମ୍ଳ	(iv)	+ 2	
	(v)	+ 1	

ନିମ୍ନଲିଖିତ ବିକଳ୍ପ ମଧ୍ୟରୁ ସଠିକ୍ ଉତ୍ତରଟିକୁ ବାଛ :

Options :

8643511465. (a)-(v), (b)-(iv), (c)-(ii), (d)-(iii)

8643511466. (a)-(iv), (b)-(i), (c)-(ii), (d)-(iii)

8643511467. (a)-(iv), (b)-(v), (c)-(ii), (d)-(iii)

8643511468. (a)-(v), (b)-(i), (c)-(ii), (d)-(iii)

Question Number : 38 Question Id : 864351488 Question Type : MCQ Option Shuffling : Yes Is Question Mandatory : No

Correct Marks : 4 Wrong Marks : 1

Given below are two statement : one is labelled as Assertion A and the other is labelled as Reason R :

Assertion A : Size of Bk^{3+} ion is less than Np^{3+} ion.

Reason R : The above is a consequence of the lanthanoid contraction.

In the light of the above statements, choose the correct answer from the options given below :

Options :

8643511469. Both A and R are true and R is the correct explanation of A

8643511470. Both A and R are true but R is not the correct explanation of A

8643511471. A is true but R is false

8643511472. A is false but R is true

Question Number : 38 Question Id : 864351488 Question Type : MCQ Option Shuffling : Yes Is Question Mandatory : No

Correct Marks : 4 Wrong Marks : 1

ନିମ୍ନରେ ଦୁଇଟି ଉକ୍ତି ଦିଆଯାଇଛି । ଗୋଟିଏ ଦୃଢ଼ୋକ୍ତି A ଏବଂ ଅନ୍ୟଟି କାରଣ R ।

ଦୃଢ଼ୋକ୍ତି A : Bk^{3+} ଆୟନର ଆକାର Np^{3+} ଆୟନ ଅପେକ୍ଷା କମ୍ ସ୍ଥର ଅଟେ ।

କାରଣ R : ଉପରୋକ୍ତି ଲାନ୍ଥାନାଇଡ଼ ସଂକୋଚନର ଫଳାଫଳ ଅଟେ ।

ଉପରୋକ୍ତ ଉକ୍ତି ଅନୁସାରେ, ନିମ୍ନ ପ୍ରଦତ୍ତ ବିକଳ୍ପ ମଧ୍ୟରୁ ସଠିକ୍ ଉତ୍ତରଟି ବାଛି :

Options :

8643511469. ଉଭୟ A ଏବଂ R ସତ୍ୟ ଅଟେ ଏବଂ A ର ସଠିକ୍ ବ୍ୟାଖ୍ୟା ହେଉଛି R ।

8643511470. ଉଭୟ A ଏବଂ R ସତ୍ୟ ଅଟେ କିନ୍ତୁ A ର ସଠିକ୍ ବ୍ୟାଖ୍ୟା ନୁହେଁ R ।

8643511471. A ସତ୍ୟ ଅଟେ କିନ୍ତୁ R ମିଥ୍ୟା ଅଟେ ।

8643511472. A ମିଥ୍ୟା ଅଟେ କିନ୍ତୁ R ସତ୍ୟ ଅଟେ ।

Question Number : 39 Question Id : 864351489 Question Type : MCQ Option Shuffling : Yes Is Question Mandatory : No

Correct Marks : 4 Wrong Marks : 1

Given below are two statements :

Statement I : The E° value for Ce^{4+}/Ce^{3+} is +1.74 V.

Statement II : Ce is more stable in Ce^{4+} state than Ce^{3+} state.

In the light of the above statements, choose the most appropriate answer from the options given below :

Options :

8643511473. Both statement I and statement II are correct

8643511474. Both statement I and statement II are incorrect

8643511475. Statement I is correct but statement II is incorrect

8643511476. Statement I is incorrect but statement II is correct

Question Number : 39 Question Id : 864351489 Question Type : MCQ Option Shuffling : Yes Is Question Mandatory : No

Correct Marks : 4 Wrong Marks : 1

ନିମ୍ନରେ ଦୁଇଟି ଉକ୍ତି ଦିଆଯାଇଛି :

ଉକ୍ତି I : Ce^{4+}/Ce^{3+} ର E° ମୂଲ୍ୟ +1.74 V ।

ଉକ୍ତି II : Ce ର Ce^{4+} ଅବସ୍ଥା Ce^{3+} ଅବସ୍ଥା ଅପେକ୍ଷା ଅଧିକ ସ୍ଥିର ।

ଉପରୋକ୍ତ ଉକ୍ତି ଅନୁସାରେ, ନିମ୍ନଲିଖିତ ବିକଳ୍ପ ମଧ୍ୟରୁ ସର୍ବାଧିକ ଉପଯୁକ୍ତ ଉତ୍ତରଟିକୁ ବାଛି ।

Options :

8643511473. ଉଭୟ ଉକ୍ତି I ଏବଂ ଉକ୍ତି II ସଠିକ୍ ଅଟେ ।

8643511474. ଉଭୟ ଉକ୍ତି I ଏବଂ ଉକ୍ତି II ଭୁଲ୍ ଅଟେ ।

8643511475. ଉକ୍ତି I ସଠିକ୍ ଅଟେ କିନ୍ତୁ ଉକ୍ତି II ଭୁଲ୍ ଅଟେ ।

8643511476. ଉକ୍ତି I ଭୁଲ୍ ଅଟେ କିନ୍ତୁ ଉକ୍ତି II ସଠିକ୍ ଅଟେ ।

Question Number : 40 Question Id : 864351490 Question Type : MCQ Option Shuffling : Yes Is Question Mandatory : No

Correct Marks : 4 Wrong Marks : 1

The type of pollution that gets increased during the day time and in the presence of O_3 is :

Options :

8643511477. Reducing smog

8643511478. Oxidising smog

8643511479. Acid rain

8643511480. Global warming

Question Number : 40 Question Id : 864351490 Question Type : MCQ Option Shuffling : Yes Is Question Mandatory : No

Correct Marks : 4 Wrong Marks : 1

O_3 ଉପସ୍ଥିତିରେ ଏବଂ ଦିନ ସମୟରେ ବହୁଥିବା ପ୍ରଦୂଷଣର ପ୍ରକାର ହେଉଛି :

Options :

8643511477. ବିଜାରଣ ସ୍ମଗ୍

8643511478. ଜାରଣ ସ୍ମଗ୍

8643511479. ଅମ୍ଳ ବର୍ଷା

8643511480. ଭୂମଣ୍ଡଳୀୟ ଉଷ୍ମତା

Question Number : 41 Question Id : 864351491 Question Type : MCQ Option Shuffling : Yes Is Question Mandatory : No

Correct Marks : 4 Wrong Marks : 1

In chromatography technique, the purification of compound is independent of :

Options :

8643511481. Solubility of the compound

8643511482. Mobility or flow of solvent system

8643511483. Length of the column or TLC plate

8643511484. Physical state of the pure compound

Question Number : 41 Question Id : 864351491 Question Type : MCQ Option Shuffling : Yes Is Question Mandatory : No

Correct Marks : 4 Wrong Marks : 1

କ୍ରୋମାଟୋଗ୍ରାଫି ଟେକନିକରେ ଯୌଗିକର ବିଶୁଦ୍ଧିକରଣ ନିର୍ଭର କରୁନଥିବା ବିକଳ୍ପଟି ହେଉଛି :

Options :

8643511481. ଯୌଗିକର ଦ୍ରବଣୀୟତା

8643511482. ଦ୍ରବଣର ଗତି କିମ୍ବା ପ୍ରବାହ

8643511483. ଉତ୍ସ କିମ୍ବା TLC ପ୍ଲେଟ୍ରେ ଲମ୍ବ

8643511484. ବିଶୁଦ୍ଧ ଯୌଗିକର ଭୌତିକ ଅବସ୍ଥା

Question Number : 42 Question Id : 864351492 Question Type : MCQ Option Shuffling : Yes Is Question Mandatory : No

Correct Marks : 4 Wrong Marks : 1

Among the following, the aromatic compounds are :

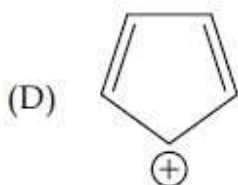
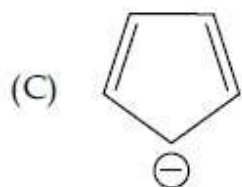
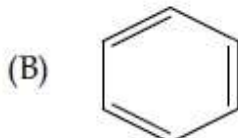

Choose the correct answer from the following options :

Options :

8643511485. (A) and (B) only

8643511486. (A), (B) and (C) only

8643511487. (B), (C) and (D) only

8643511488. (B) and (C) only

Question Number : 42 Question Id : 864351492 Question Type : MCQ Option Shuffling : Yes Is Question Mandatory : No

Correct Marks : 4 Wrong Marks : 1

ନିମ୍ନଲିଖିତ ମଧ୍ୟରୁ ଆରୋମାଟିକ୍ ଯୌଗିକ ଗୁଡ଼ିକ ହେଉଛି :

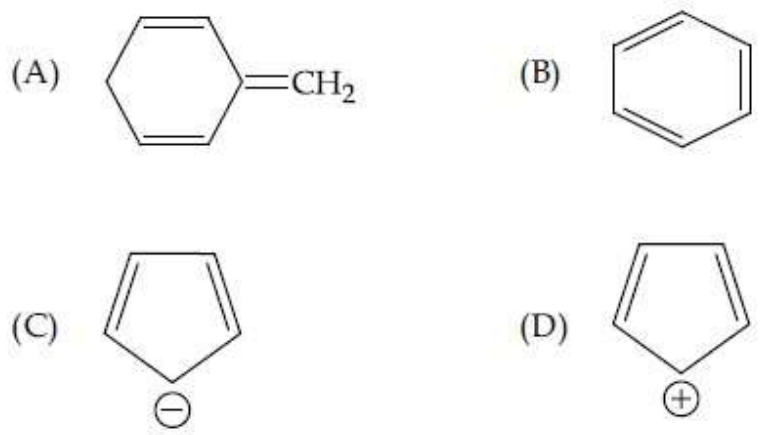

ନିମ୍ନଲିଖିତ ବିକଳ୍ପ ମଧ୍ୟରୁ ସଠିକ୍ ଉତ୍ତରଟିକୁ ବାଛି :

Options :

8643511485. (A) ଏବଂ (B) କେବଳ

8643511486. (A), (B) ଏବଂ (C) କେବଳ

8643511487. (B), (C) ଏବଂ (D) କେବଳ

8643511488. (B) ଏବଂ (C) କେବଳ

Question Number : 43 Question Id : 864351493 Question Type : MCQ Option Shuffling : Yes Is Question Mandatory : No

Correct Marks : 4 Wrong Marks : 1

Which of the following is Lindlar catalyst ?

Options :

8643511489. Partially deactivated palladised charcoal

8643511490. Sodium and Liquid NH₃

8643511491. Cold dilute solution of KMnO₄

8643511492. Zinc chloride and HCl

Question Number : 43 Question Id : 864351493 Question Type : MCQ Option Shuffling : Yes Is Question Mandatory : No

Correct Marks : 4 Wrong Marks : 1

ନିମ୍ନଲିଖିତ ମଧ୍ୟରୁ କେଉଁଟି ଲିଓଲାଲ ଉତ୍ପେରକ ?

Options :

8643511489. ଆଂଶିକ ନିସ୍ତୁୟ ଯାଲାତାଲଜଡ଼ ଅକାର

8643511490. ସୋଡ଼ିୟମ୍ ଏବଂ ଚରକ ଆମୋନିଆ

8643511491. KMnO_4 ର ଅଣ୍ଡା ଲଘୁ ଦ୍ରବଣ

8643511492. ଜିଙ୍କ୍ କ୍ଲୋରାଇଡ଼ ଏବଂ HCl

Question Number : 44 Question Id : 864351494 Question Type : MCQ Option Shuffling : Yes Is Question Mandatory : No

Correct Marks : 4 Wrong Marks : 1

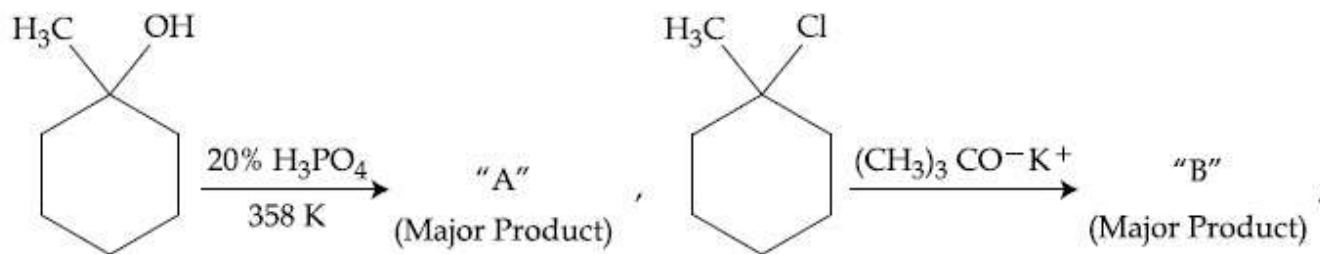

The products "A" and "B" formed in above reactions are :

Options :

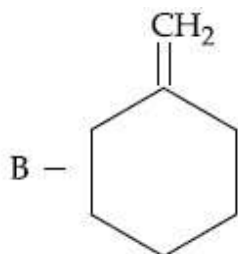
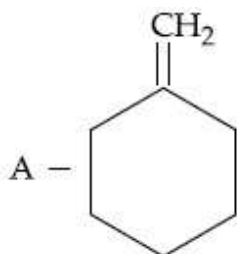

8643511493.

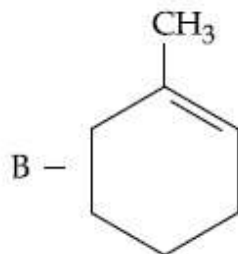
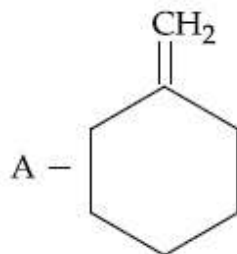

8643511494.

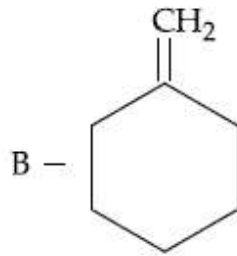
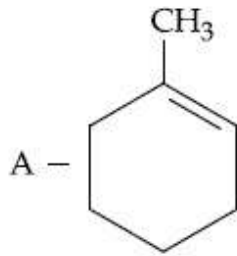

8643511495.

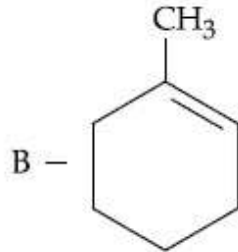
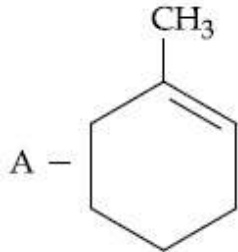

8643511496.

Question Number : 44 Question Id : 864351494 Question Type : MCQ Option Shuffling : Yes Is Question Mandatory : No

Correct Marks : 4 Wrong Marks : 1

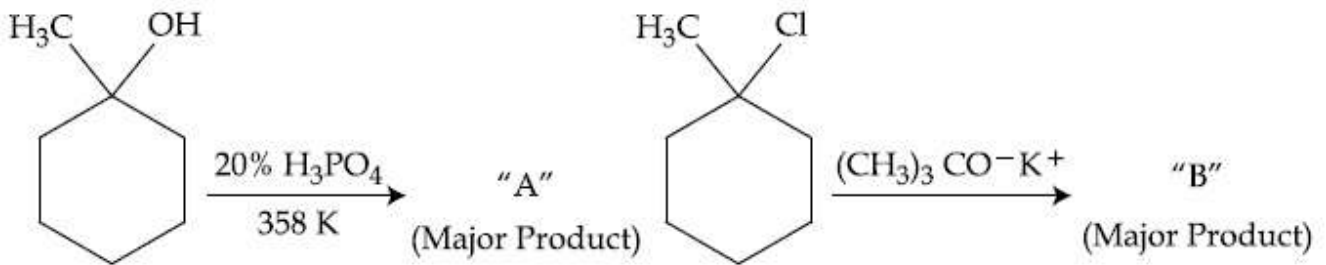

ଉପରୋକ୍ତ ପ୍ରତିକ୍ରିୟାରେ ଗଠିତ ଉତ୍ପାଦ "A" ଏବଂ "B" ହେଉଛି :

Options :

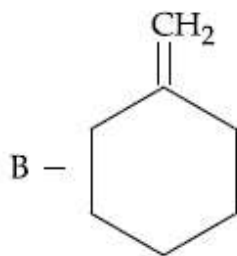
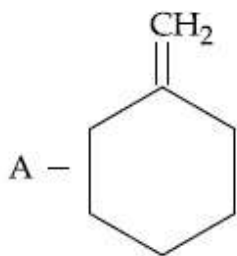

8643511493.

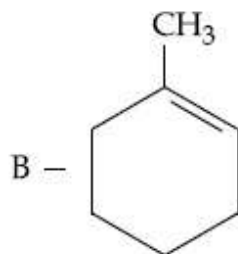
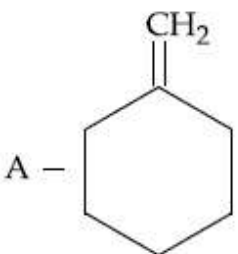

8643511494.

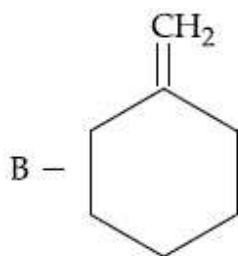
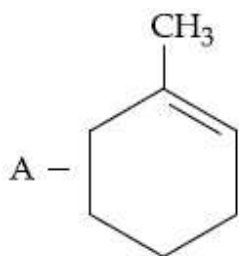

8643511495.

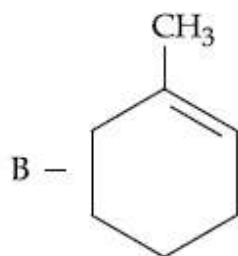
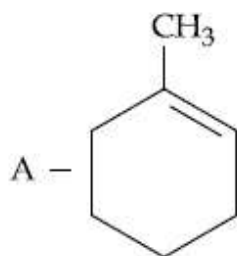

8643511496.

Question Number : 45 Question Id : 864351495 Question Type : MCQ Option Shuffling : Yes Is Question Mandatory : No

Correct Marks : 4 Wrong Marks : 1

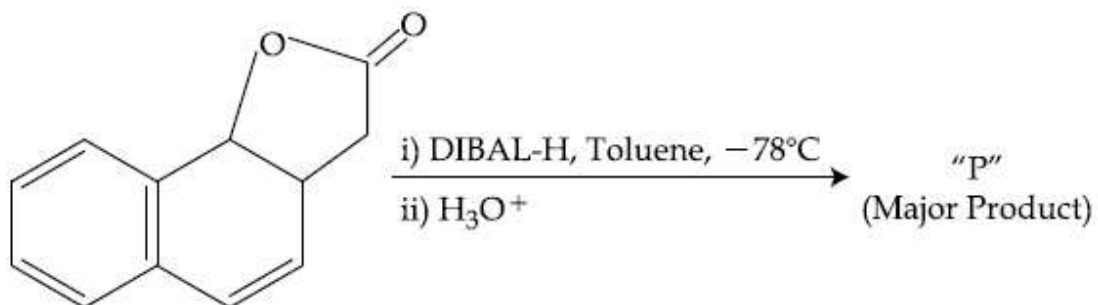

The product "P" in the above reaction is :

Options :

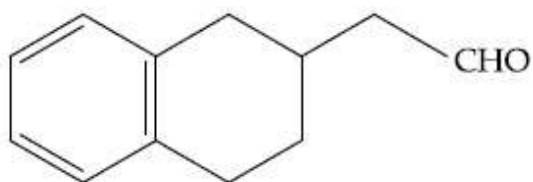

8643511497.

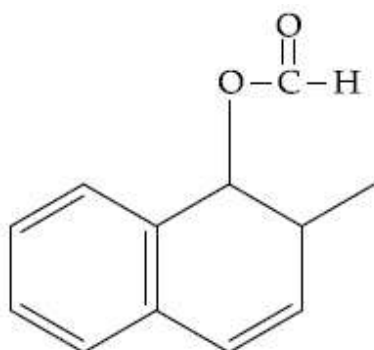

8643511498.

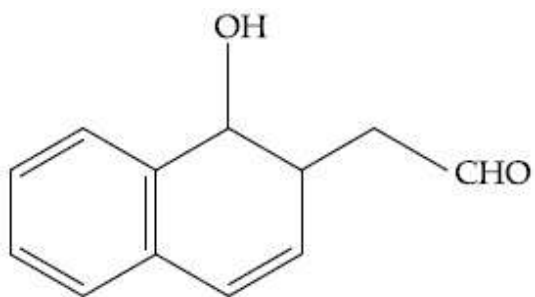

8643511499.

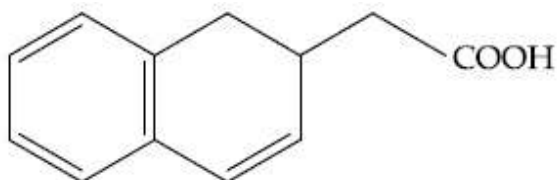

8643511500.

Question Number : 45 Question Id : 864351495 Question Type : MCQ Option Shuffling : Yes Is Question Mandatory : No

Correct Marks : 4 Wrong Marks : 1

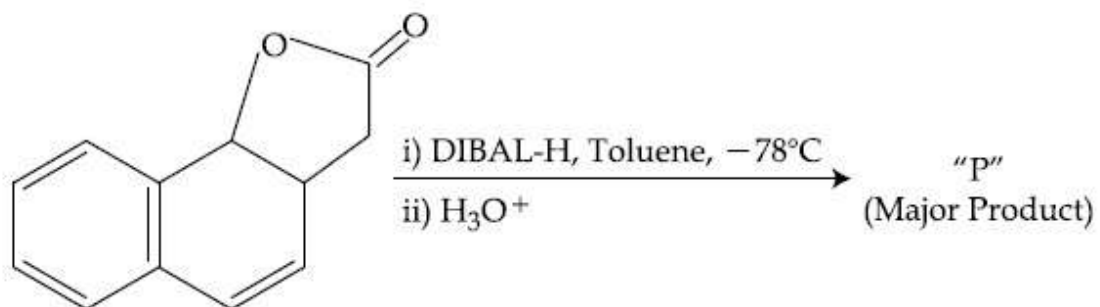

ଉପରୋକ୍ତ ପ୍ରତିକ୍ରିୟାରେ ଗଠିତ ଉତ୍ପାଦ "P" ହେଉଛି :

Options :

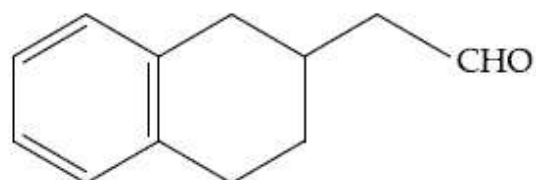

8643511497.

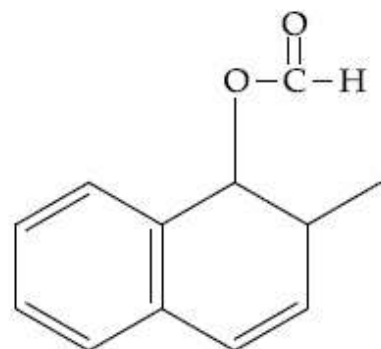

8643511498.

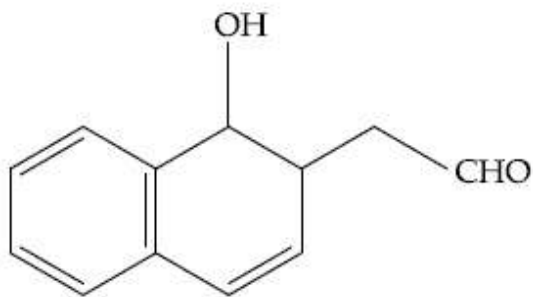

8643511499.

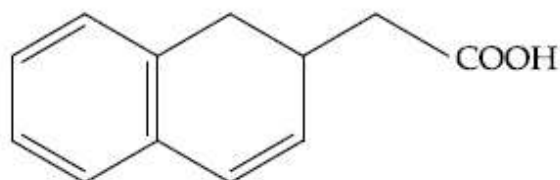

8643511500.

Question Number : 46 Question Id : 864351496 Question Type : MCQ Option Shuffling : Yes Is Question Mandatory : No

Correct Marks : 4 Wrong Marks : 1

Assertion A : Enol form of acetone [CH_3COCH_3] exists in $< 0.1\%$ quantity. However, the enol form of acetyl acetone [$\text{CH}_3\text{COCH}_2\text{OCCH}_3$] exists in approximately 15% quantity.

Reason R : Enol form of acetyl acetone is stabilized by intramolecular hydrogen bonding, which is not possible in enol form of acetone.

Choose the correct statement :

Options :

8643511501. Both A and R are true and R is the correct explanation of A

8643511502. Both A and R are true but R is not the correct explanation of A

8643511503. A is true but R is false

8643511504. A is false but R is true

Question Number : 46 Question Id : 864351496 Question Type : MCQ Option Shuffling : Yes Is Question Mandatory : No

Correct Marks : 4 Wrong Marks : 1

ଦୃଢ଼ୋକ୍ତି **A** : ଏସିଟୋନ୍ $[CH_3COCH_3]$ ର ଜନଲ ଆକାରର ପରିମାଣ $< 0.1\%$ । ସେ ଯାହା ହେଉନା କହିଲେ ଏସିଟିଲ୍ ଏସିଟୋନ୍ $[CH_3COCH_2OCCH_3]$ ର ଜନଲ ଆକାରର ଆନୁମାନିକ ପରିମାଣ 15% ।

କାରଣ **R** : ଇଣ୍ଡ୍ରାମଲିକୁଲାର ହାଇଡ୍ରୋଜେନ୍ ବନ୍ଧ ଦ୍ୱାରା ଏସିଟିଲ୍ ଏସିଟୋନ୍ର ଜନଲ ଆକାର ସ୍ଥିରତା ପ୍ରାପ୍ତି କରିଥାଏ ଯାହାକି ଏସିଟୋନ୍ର ଜନଲ ଆକାରରେ ତାହା ସମ୍ଭବ ହୁଏ ନାହିଁ ।

ସଠିକ୍ ଉକ୍ତିଟିକୁ ବାଛି :

Options :

8643511501. ଉଭୟ **A** ଏବଂ **R** ସତ୍ୟ ଅଟେ ଏବଂ **A** ର ସଠିକ୍ ବ୍ୟାଖ୍ୟା ହେଉଛି **R** ।

8643511502. ଉଭୟ **A** ଏବଂ **R** ସତ୍ୟ ଅଟେ କିନ୍ତୁ **A** ର ସଠିକ୍ ବ୍ୟାଖ୍ୟା ନୁହେଁ **R** ।

8643511503. **A** ସତ୍ୟ ଅଟେ କିନ୍ତୁ **R** ମିଥ୍ୟା ଅଟେ ।

8643511504. **A** ମିଥ୍ୟା ଅଟେ କିନ୍ତୁ **R** ସତ୍ୟ ଅଟେ ।

Question Number : 47 Question Id : 864351497 Question Type : MCQ Option Shuffling : Yes Is Question Mandatory : No

Correct Marks : 4 Wrong Marks : 1

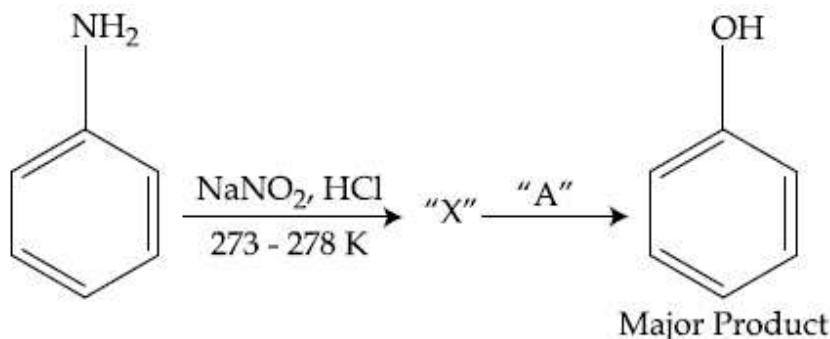

In the above chemical reaction, intermediate "X" and reagent/condition "A" are :

Options :

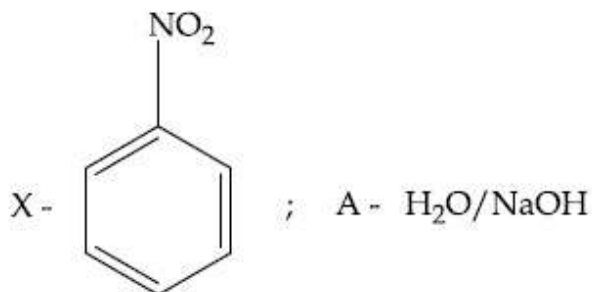

8643511505.

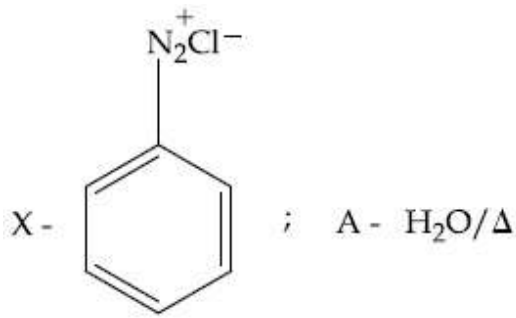

8643511506.

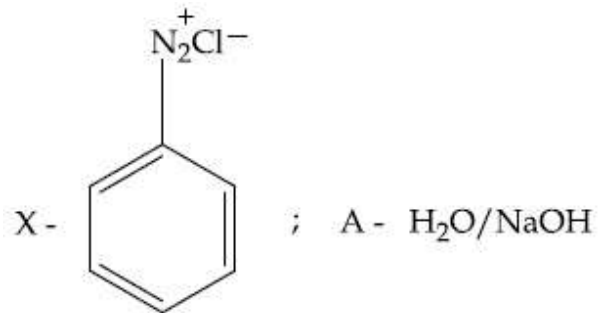

8643511507.

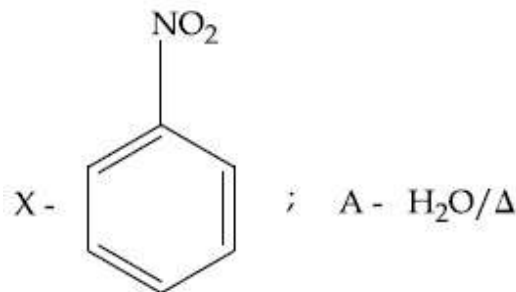

8643511508.

Question Number : 47 Question Id : 864351497 Question Type : MCQ Option Shuffling : Yes Is Question Mandatory : No

Correct Marks : 4 Wrong Marks : 1

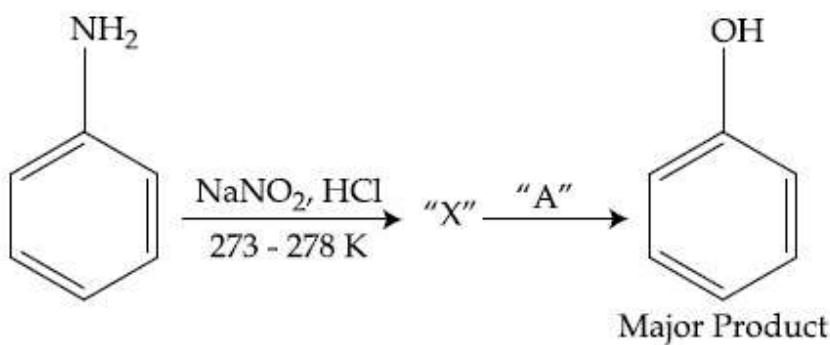

ଉପରୋକ୍ତ ରାସାୟନିକ ପ୍ରକ୍ରିୟାରେ, ମଧ୍ୟବର୍ତ୍ତୀ "X" ଏବଂ ଅଭିକର୍ଷକ/ସର୍ତ୍ତ "A" ହେଉଛନ୍ତି :

Options :

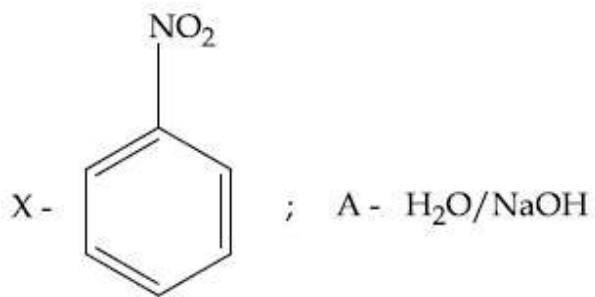

8643511505.

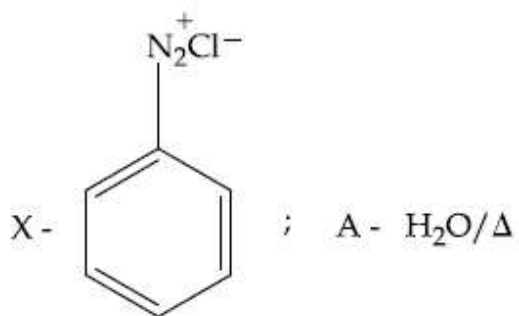

8643511506.

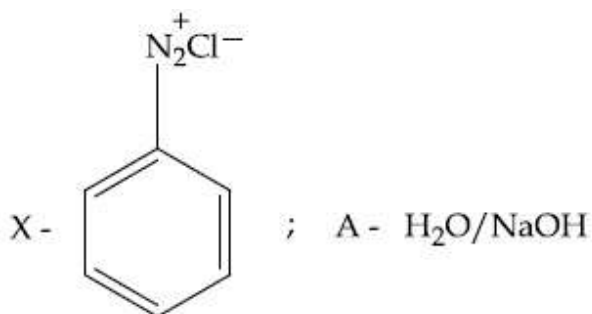

8643511507.

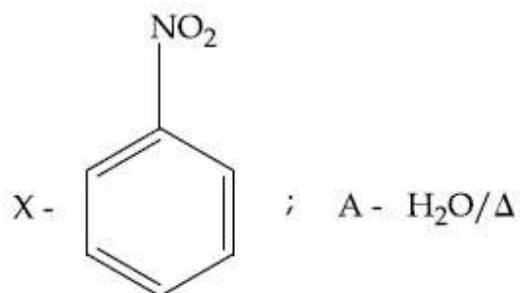

8643511508.

Question Number : 48 Question Id : 864351498 Question Type : MCQ Option Shuffling : Yes Is Question Mandatory : No

Correct Marks : 4 Wrong Marks : 1

Which of the following reaction DOES NOT involve Hoffmann bromamide degradation ?

Options :

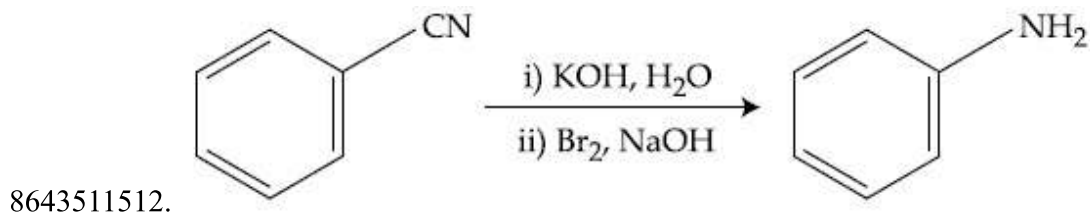
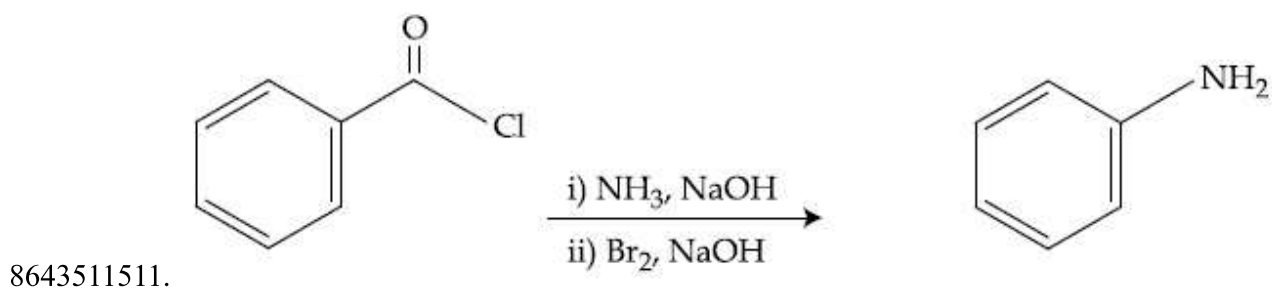
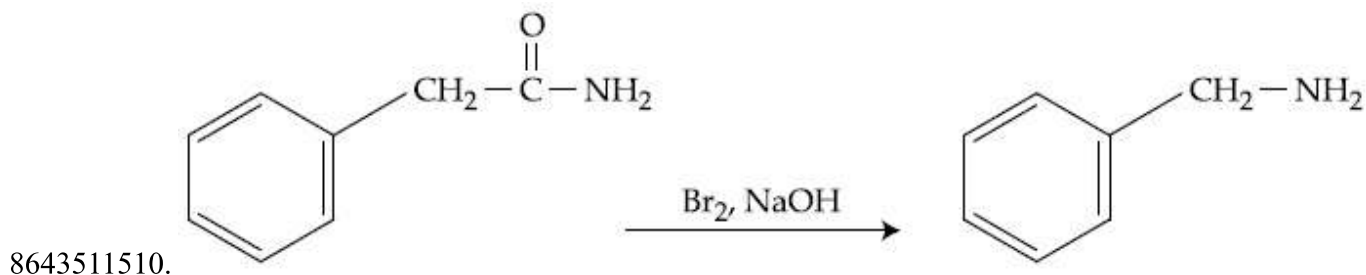
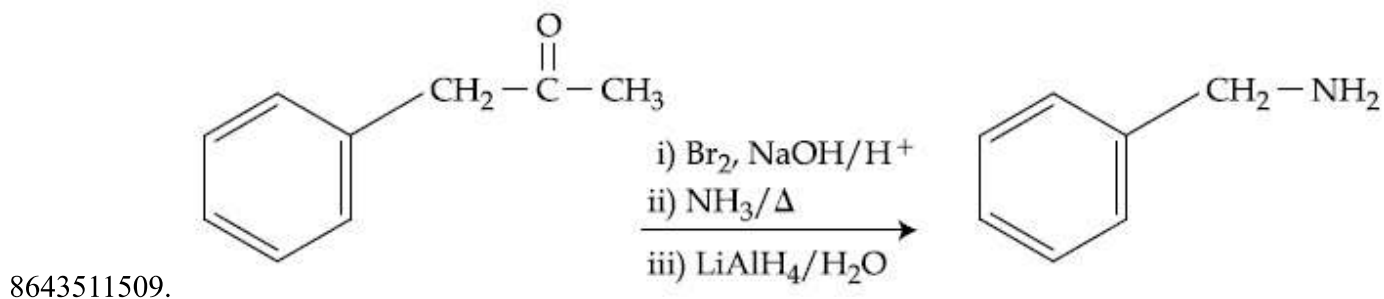

Question Number : 48 Question Id : 864351498 Question Type : MCQ Option Shuffling : Yes Is Question Mandatory : No

Correct Marks : 4 Wrong Marks : 1

ନିମ୍ନଲିଖିତ କେଉଁ ପ୍ରତିକ୍ରିୟାଟି ହଫମାନ୍ ଡ୍ରୋମାମାଇଡ୍ ଅବକ୍ରମଣ ସହିତ ସଂପୃକ୍ତ ନୁହେଁ ?

Options :

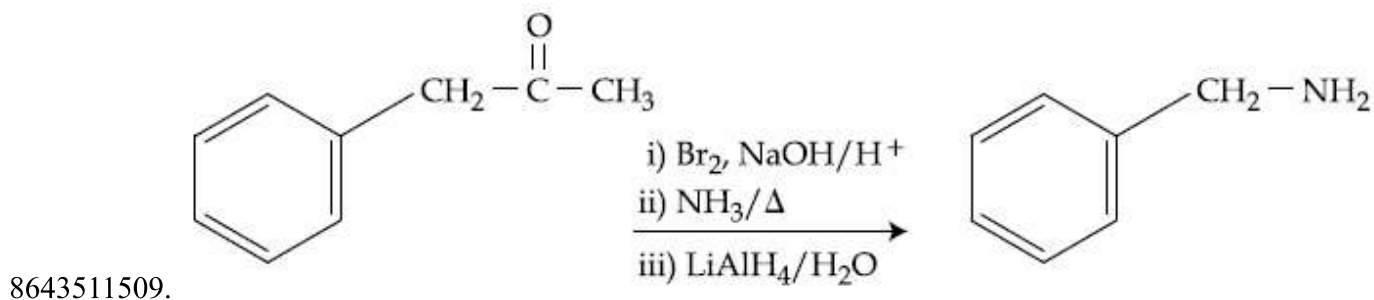

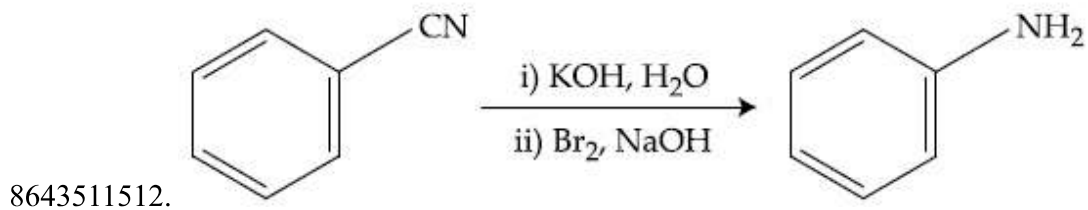
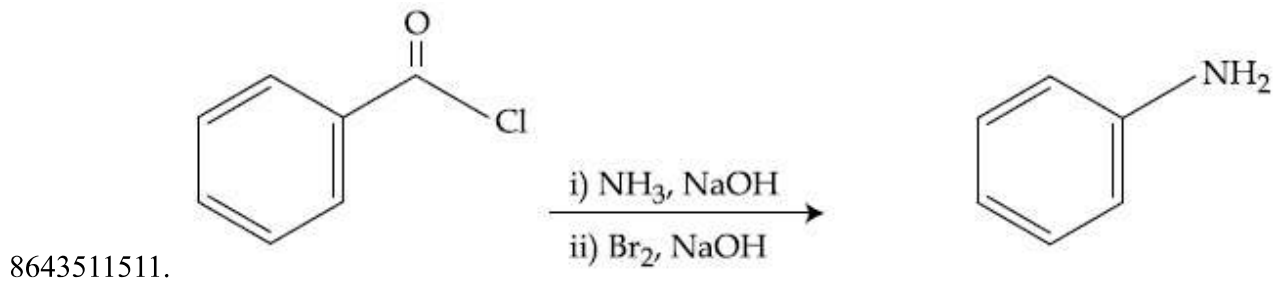
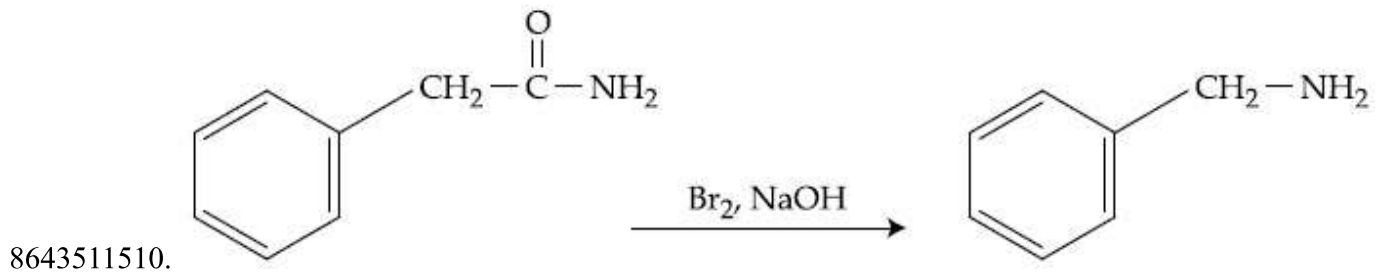

Question Number : 49 Question Id : 864351499 Question Type : MCQ Option Shuffling : Yes Is Question Mandatory : No

Correct Marks : 4 Wrong Marks : 1

The functions of antihistamine are :

Options :

8643511513. Antiallergic and Analgesic

8643511514. Analgesic and antacid

8643511515. Antacid and antiallergic

8643511516. Antiallergic and antidepressant

Question Number : 49 Question Id : 864351499 Question Type : MCQ Option Shuffling : Yes Is Question Mandatory : No

Correct Marks : 4 Wrong Marks : 1

ଏକାନ୍ତକାଳୀନ କାର୍ଯ୍ୟଗୁଡ଼ିକ ହେଉଛି :

Options :

8643511513. ଆଣ୍ଟିସଲାରଜିକ୍ ଏବଂ ଏନାଲଜେସିକ୍

8643511514. ଏନାଲଜେସିକ୍ ଏବଂ ପ୍ରତିଅମ୍ଳ

8643511515. ପ୍ରତିଅମ୍ଳ ଏବଂ ଆଣ୍ଟିସଲାରଜିକ୍

8643511516. ଆଣ୍ଟିସଲାରଜିକ୍ ଏବଂ ଆଣ୍ଟିଡିପ୍ରେସାଣ୍ଟ

Question Number : 50 Question Id : 864351500 Question Type : MCQ Option Shuffling : Yes Is Question Mandatory : No

Correct Marks : 4 Wrong Marks : 1

Which among the following pairs of Vitamins is stored in our body relatively for longer duration ?

Options :

8643511517. Thiamine and Ascorbic acid

8643511518. Vitamin A and Vitamin D

8643511519. Thiamine and Vitamin A

8643511520. Ascorbic acid and Vitamin D

Question Number : 50 Question Id : 864351500 Question Type : MCQ Option Shuffling : Yes Is Question Mandatory : No

Correct Marks : 4 Wrong Marks : 1

ନିମ୍ନଲିଖିତ ମଧ୍ୟରୁ କେଉଁ ଭିଟାମିନ୍ ଯୋଡ଼ାଟି ଆମ ଶରୀରରେ ଅପେକ୍ଷାକୃତ ଅଧିକ ସମୟ ଗଚ୍ଛିତ ରହିଥାଏ ?

Options :

8643511517. ଥିଆମିନ୍ ଏବଂ ଏସ୍କରବିକ୍ ଅମ୍ଳ

8643511518. ଭିଟାମିନ୍ A ଏବଂ ଭିଟାମିନ୍ D

8643511519. ଥିଆମିନ୍ ଏବଂ ଭିଟାମିନ୍ A

8643511520. ଏସ୍କରବିକ୍ ଅମ୍ଳ ଏବଂ ଭିଟାମିନ୍ D

Chemistry Section B

Section Id :	86435134
Section Number :	4
Section type :	Online
Mandatory or Optional :	Mandatory
Number of Questions :	10
Number of Questions to be attempted :	5
Section Marks :	20
Mark As Answered Required? :	Yes
Sub-Section Number :	1
Sub-Section Id :	86435134
Question Shuffling Allowed :	Yes

Question Number : 51 Question Id : 864351501 Question Type : SA

Correct Marks : 4 Wrong Marks : 0

A 6.50 molal solution of KOH (aq.) has a density of 1.89 g cm^{-3} . The molarity of the solution is _____ mol dm^{-3} . (Round off to the Nearest Integer).

[Atomic masses : K : 39.0 u; O : 16.0 u; H : 1.0 u]

Response Type : Numeric

Evaluation Required For SA : Yes

Show Word Count : Yes

Answers Type : Equal

Text Areas : PlainText

Possible Answers :

100

Question Number : 51 Question Id : 864351501 Question Type : SA

Correct Marks : 4 Wrong Marks : 0

6.50 ମୋଲାଲ KOH (aq.) ଦ୍ରବଣର ସାନ୍ଦ୍ରତା 1.89 g cm^{-3} । ଦ୍ରବଣର ମୋଲାରଟି ହେଉଛି _____ mol dm^{-3} । (ନିକଟତମ ପୂର୍ଣ୍ଣସଂଖ୍ୟାରେ ପରିଣତ କର)

[ଆଣବିକ ବସ୍ତୁତ୍ଵ : K : 39.0 u; O : 16.0 u; H : 1.0 u]

Response Type : Numeric

Evaluation Required For SA : Yes

Show Word Count : Yes

Answers Type : Equal

Text Areas : PlainText

Possible Answers :

100

Question Number : 52 Question Id : 864351502 Question Type : SA

Correct Marks : 4 Wrong Marks : 0

A certain element crystallises in a bcc lattice of unit cell edge length 27\AA . If the same element under the same conditions crystallises in the fcc lattice, the edge length of the unit cell in \AA will be _____. (Round off to the Nearest Integer).

[Assume each lattice point has a single atom]

[Assume $\sqrt{3} = 1.73$, $\sqrt{2} = 1.41$]

Response Type : Numeric

Evaluation Required For SA : Yes

Show Word Count : Yes

Answers Type : Equal

Text Areas : PlainText

Possible Answers :

100

Question Number : 52 **Question Id :** 864351502 **Question Type :** SA

Correct Marks : 4 **Wrong Marks :** 0

ଗୋଟିଏ ନିର୍ଦ୍ଦିଷ୍ଟ ଉପାଦାନ ଏକ ଇଉନିଟ୍ ସେଲ୍ ପାର୍ଶ୍ୱ ଲମ୍ବ 27\AA bcc ଲାଟିସ୍‌ରେ ଦାନା ବାନ୍ଧେ । ଯଦି ସେହି ଉପାଦାନ ସମାନ ଅବସ୍ଥା ମଧ୍ୟରେ fcc ଲାଟିସ୍‌ରେ ଦାନା ବାନ୍ଧେ ତେବେ ଏକକ ସେଲ୍ ପାର୍ଶ୍ୱ ଦୈର୍ଘ୍ୟ \AA ରେ ହେବ _____ । (ନିକଟତମ ପୂର୍ଣ୍ଣସଂଖ୍ୟାରେ)

(ଧରାଯାଉ ଲାଟିସ୍ ପଦ୍ମର ଗୋଟିଏ ପରମାଣୁ ଅଛି, $\sqrt{3} = 1.73$, $\sqrt{2} = 1.41$)

Response Type : Numeric

Evaluation Required For SA : Yes

Show Word Count : Yes

Answers Type : Equal

Text Areas : PlainText

Possible Answers :

100

Question Number : 53 **Question Id :** 864351503 **Question Type :** SA

Correct Marks : 4 **Wrong Marks :** 0

When light of wavelength 248 nm falls on a metal of threshold energy 3.0 eV , the de-Broglie wavelength of emitted electrons is _____ \AA . (Round off to the Nearest Integer).

[Use : $\sqrt{3} = 1.73$, $h = 6.63 \times 10^{-34}\text{ Js}$

$m_e = 9.1 \times 10^{-31}\text{ kg}$; $c = 3.0 \times 10^8\text{ ms}^{-1}$; $1\text{ eV} = 1.6 \times 10^{-19}\text{ J}$]

Response Type : Numeric

Evaluation Required For SA : Yes

Show Word Count : Yes

Answers Type : Equal

Text Areas : PlainText

Possible Answers :

Question Number : 53 Question Id : 864351503 Question Type : SA

Correct Marks : 4 Wrong Marks : 0

248 nm ତରଙ୍ଗ ଦୈର୍ଘ୍ୟ ଥିବା ଆଲୋକ ଯେତେବେଳେ ଏକ ଧାତୁ ଯାହାର ପ୍ରାରମ୍ଭିକ ଶକ୍ତି 3.0 eV ଉପରେ ପଡ଼େ, ନିର୍ଗତ ଇଲେକ୍ଟ୍ରନ୍‌ର ଡିବ୍ରଗିଲାଇ ତରଙ୍ଗ ଦୈର୍ଘ୍ୟ _____ Å ଅଟେ । (ନିକଟତମ ପୂର୍ଣ୍ଣସଂଖ୍ୟାରେ ପରିଣତ କର)

[ବ୍ୟବହାର କର : $\sqrt{3} = 1.73$, $h = 6.63 \times 10^{-34}$ Js

$m_e = 9.1 \times 10^{-31}$ kg ; $c = 3.0 \times 10^8$ ms⁻¹ ; 1eV = 1.6 × 10⁻¹⁹J]

Response Type : Numeric

Evaluation Required For SA : Yes

Show Word Count : Yes

Answers Type : Equal

Text Areas : PlainText

Possible Answers :

100

Question Number : 54 Question Id : 864351504 Question Type : SA

Correct Marks : 4 Wrong Marks : 0

For the reaction $A(g) \rightleftharpoons B(g)$ at 495 K, $\Delta_r G^\circ = -9.478$ kJ mol⁻¹.

If we start the reaction in a closed container at 495 K with 22 millimoles of A, the amount of B in the equilibrium mixture is _____ millimoles. (Round off to the Nearest Integer).

[R = 8.314 J mol⁻¹ K⁻¹ ; ln 10 = 2.303]

Response Type : Numeric

Evaluation Required For SA : Yes

Show Word Count : Yes

Answers Type : Equal

Text Areas : PlainText

Possible Answers :

100

Question Number : 54 Question Id : 864351504 Question Type : SA

Correct Marks : 4 Wrong Marks : 0

ପ୍ରତିକ୍ରିୟାଟି 495 K ରେ $A(g) \rightleftharpoons B(g)$, $\Delta_r G^\circ = -9.478$ kJ mol⁻¹ ଯଦି 495 K ତାପମାତ୍ରାରେ 22 ମିଲିମୋଲ୍‌ସ A ସହିତ ଏକ ବନ୍ଦ ପାତ୍ରରେ ପ୍ରତିକ୍ରିୟା ଆରମ୍ଭ କରାଯାଏ ତାହେଲେ ସାମ୍ୟ ମିଶ୍ରଣରେ B ର ପରିମାଣ _____ ମିଲି ମୋଲ୍‌ସ ଅଟେ । (ନିକଟତମ ପୂର୍ଣ୍ଣସଂଖ୍ୟାରେ ପରିଣତ କର)

[R = 8.314 J mol⁻¹ K⁻¹ ; ln 10 = 2.303]

Response Type : Numeric

Evaluation Required For SA : Yes

Show Word Count : Yes

Answers Type : Equal

Text Areas : PlainText

Possible Answers :

100

Question Number : 55 Question Id : 864351505 Question Type : SA

Correct Marks : 4 Wrong Marks : 0

AB_2 is 10% dissociated in water to A^{2+} and B^- . The boiling point of a 10.0 molal aqueous solution of AB_2 is _____ $^{\circ}C$. (Round off to the Nearest Integer).

[Given : Molal elevation constant of water $K_b = 0.5 \text{ K kg mol}^{-1}$ boiling point of pure water = $100^{\circ}C$]

Response Type : Numeric

Evaluation Required For SA : Yes

Show Word Count : Yes

Answers Type : Equal

Text Areas : PlainText

Possible Answers :

100

Question Number : 55 Question Id : 864351505 Question Type : SA

Correct Marks : 4 Wrong Marks : 0

AB_2 ଜଳରେ 10% ଅଣୁ ପୃଥକୀକରଣ କରି A^{2+} ଏବଂ B^- ସୃଷ୍ଟି କରନ୍ତି । 10.0 ମୋଲାଲ AB_2 ଜଳୀୟ ଦ୍ରବଣର ସ୍ଵତନ୍ତ୍ରତା ହେଉଛି _____ $^{\circ}C$ । (ନିକଟତମ ପୂର୍ଣ୍ଣସଂଖ୍ୟାରେ ପରିଣତ କର)

(ଦତ୍ତ : ଜଳର ମୋଲାଲ ଉତ୍ତୋତ୍ତନ ସ୍ଥିରାଙ୍କ $K_b = 0.5 \text{ K kg mol}^{-1}$, ବିଶୁଦ୍ଧ ଜଳର ସ୍ଵତନ୍ତ୍ରତା = $100^{\circ}C$)

Response Type : Numeric

Evaluation Required For SA : Yes

Show Word Count : Yes

Answers Type : Equal

Text Areas : PlainText

Possible Answers :

100

Question Number : 56 Question Id : 864351506 Question Type : SA

Correct Marks : 4 Wrong Marks : 0

Two salts A_2X and MX have the same value of solubility product of 4.0×10^{-12} . The ratio of

their molar solubilities i.e. $\frac{S(A_2X)}{S(MX)} = \text{_____}$. (Round off to the Nearest Integer).

Response Type : Numeric

Evaluation Required For SA : Yes

Show Word Count : Yes

Answers Type : Equal

Text Areas : PlainText

Possible Answers :

100

Question Number : 56 Question Id : 864351506 Question Type : SA

Correct Marks : 4 Wrong Marks : 0

ଦୁଇଟି ଲବଣ A_2X ଏବଂ MX ର ସମାନ ଦ୍ରବଣୀୟତା ଗୁଣଫଳ 4.0×10^{-12} । ସେମାନଙ୍କର ମୋଲାର ଦ୍ରବଣୀୟତାର

ଅନୁପାତ $\frac{S(A_2X)}{S(MX)} = \underline{\hspace{2cm}}$ ଅଟେ । (ନିକଟତମ ପୂର୍ଣ୍ଣସଂଖ୍ୟାରେ ପରିଣତ କର)

Response Type : Numeric

Evaluation Required For SA : Yes

Show Word Count : Yes

Answers Type : Equal

Text Areas : PlainText

Possible Answers :

100

Question Number : 57 Question Id : 864351507 Question Type : SA

Correct Marks : 4 Wrong Marks : 0

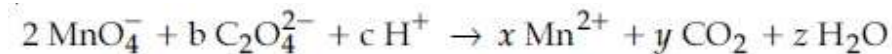

If the above equation is balanced with integer coefficients, the value of c is _____.
(Round off to the Nearest Integer).

Response Type : Numeric

Evaluation Required For SA : Yes

Show Word Count : Yes

Answers Type : Equal

Text Areas : PlainText

Possible Answers :

100

Question Number : 57 Question Id : 864351507 Question Type : SA

Correct Marks : 4 Wrong Marks : 0

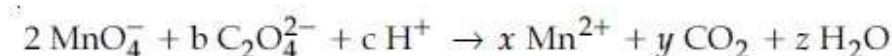

ଯଦି ଉପରୋକ୍ତ ସମୀକରଣଟି ପୂର୍ଣ୍ଣସଂଖ୍ୟା ସହଜ ଦ୍ୱାରା ସମତୁଲ୍ୟ କରାଯାଏ, c ର ମୂଲ୍ୟ _____ ଅଟେ । (ନିକଟତମ ପୂର୍ଣ୍ଣସଂଖ୍ୟାରେ ପରିଣତ କର)

Response Type : Numeric

Evaluation Required For SA : Yes

Show Word Count : Yes

Answers Type : Equal

Text Areas : PlainText

Possible Answers :

100

Question Number : 58 Question Id : 864351508 Question Type : SA

Correct Marks : 4 Wrong Marks : 0

The decomposition of formic acid on gold surface follows first order kinetics. If the rate constant at 300 K is $1.0 \times 10^{-3} \text{ s}^{-1}$ and the activation energy $E_a = 11.488 \text{ kJ mol}^{-1}$, the rate constant at 200 K is _____ $\times 10^{-5} \text{ s}^{-1}$. (Round off to the Nearest Integer).

(Given : $R = 8.314 \text{ J mol}^{-1} \text{ K}^{-1}$)

Response Type : Numeric

Evaluation Required For SA : Yes

Show Word Count : Yes

Answers Type : Equal

Text Areas : PlainText

Possible Answers :

100

Question Number : 58 Question Id : 864351508 Question Type : SA

Correct Marks : 4 Wrong Marks : 0

ସୁନାର ଉପର ଭାଗରେ ଫରମିକ୍ ଅମ୍ଳର ବିଘଟନ ପ୍ରଥମକ୍ରମ କାଇନେଟିକ୍‌କୁ ଅନୁସରଣ କରେ । 300 K ତାପମାତ୍ରାରେ ଯଦି ହାର ଛିରାଙ୍କ $1.0 \times 10^{-3} \text{ s}^{-1}$ ଏବଂ ସକ୍ରିୟତା ଶକ୍ତି $E_a = 11.488 \text{ kJ mol}^{-1}$ ହୁଏ, 200 K ତାପମାତ୍ରାରେ ହାର ଛିରାଙ୍କ _____ $\times 10^{-5} \text{ s}^{-1}$ ଅଟେ ।

(ନିକଟତମ ପୂର୍ଣ୍ଣସଂଖ୍ୟାରେ ପରିଣତ କର)

(ଦତ୍ତ : $R = 8.314 \text{ J mol}^{-1} \text{ K}^{-1}$)

Response Type : Numeric

Evaluation Required For SA : Yes

Show Word Count : Yes

Answers Type : Equal

Text Areas : PlainText

Possible Answers :

100

Question Number : 59 Question Id : 864351509 Question Type : SA

Correct Marks : 4 Wrong Marks : 0

The equivalents of ethylene diamine required to replace the neutral ligands from the coordination sphere of the trans-complex of $\text{CoCl}_3 \cdot 4\text{NH}_3$ is _____. (Round off to the Nearest Integer).

Response Type : Numeric

Evaluation Required For SA : Yes

Show Word Count : Yes

Answers Type : Equal

Text Areas : PlainText

Possible Answers :

100

Question Number : 59 Question Id : 864351509 Question Type : SA

Correct Marks : 4 Wrong Marks : 0

ପ୍ରାକୃତକ୍ଷେତ୍ର $\text{CoCl}_3 \cdot 4\text{NH}_3$ ର ସମତୁଳ୍ୟ ଗୋଲକରୁ ନିଉଟ୍ରାଲ୍ ଲିଗାଣ୍ଡ ରୁଡ଼ିକୁ ସ୍ଥାନାନ୍ତର କରିବା ପାଇଁ ଆବଶ୍ୟକ ଇଥିଲିନ୍ ଡାଇଆମିନ ତୁଲ୍ୟାଙ୍କ ହେଉଛି _____ । (ନିକଟତମ ପୂର୍ଣ୍ଣସଂଖ୍ୟାରେ ପରିଣତ କର)

Response Type : Numeric

Evaluation Required For SA : Yes

Show Word Count : Yes

Answers Type : Equal

Text Areas : PlainText

Possible Answers :

100

Question Number : 60 Question Id : 864351510 Question Type : SA

Correct Marks : 4 Wrong Marks : 0

Complete combustion of 750 g of an organic compound provides 420 g of CO_2 and 210 g of H_2O . The percentage composition of carbon and hydrogen in organic compound is 15.3 and _____ respectively. (Round off to the Nearest Integer).

Response Type : Numeric

Evaluation Required For SA : Yes

Show Word Count : Yes

Answers Type : Equal

Text Areas : PlainText

Possible Answers :

100

Question Number : 60 Question Id : 864351510 Question Type : SA

Correct Marks : 4 Wrong Marks : 0

750 g ଜୈବ ଯୌଗିକକୁ ସଂପୂର୍ଣ୍ଣ ଦହନ କଲେ 420 g CO_2 ଏବଂ 210 g H_2O ମିଳିଥାଏ । ଜୈବ ଯୌଗିକରେ କାରବନ ଏବଂ ହାଇଡ୍ରୋଜେନର ଶତକଡ଼ା ମିଶ୍ରଣ ଯଥାକ୍ରମେ 15.3 ଏବଂ _____ । (ନିକଟତମ ପୂର୍ଣ୍ଣସଂଖ୍ୟାରେ ପରିଣତ କର)

Response Type : Numeric

Evaluation Required For SA : Yes

Show Word Count : Yes

Answers Type : Equal

Text Areas : PlainText

Possible Answers :

100

Mathematics Section A

Section Id :	86435135
Section Number :	5
Section type :	Online
Mandatory or Optional :	Mandatory
Number of Questions :	20
Number of Questions to be attempted :	20
Section Marks :	80
Mark As Answered Required? :	Yes
Sub-Section Number :	1
Sub-Section Id :	86435135
Question Shuffling Allowed :	Yes

Question Number : 61 Question Id : 864351511 Question Type : MCQ Option Shuffling : Yes Is Question Mandatory : No

Correct Marks : 4 Wrong Marks : 1

Let $A = \begin{bmatrix} i & -i \\ -i & i \end{bmatrix}$, $i = \sqrt{-1}$. Then, the system of linear equations $A^8 \begin{bmatrix} x \\ y \end{bmatrix} = \begin{bmatrix} 8 \\ 64 \end{bmatrix}$ has :

Options :

8643511531. No solution

8643511532. A unique solution

8643511533. Infinitely many solutions

8643511534. Exactly two solutions

Question Number : 61 Question Id : 864351511 Question Type : MCQ Option Shuffling : Yes Is Question Mandatory : No

Correct Marks : 4 Wrong Marks : 1

ମନେକର $A = \begin{bmatrix} i & -i \\ -i & i \end{bmatrix}$, $i = \sqrt{-1}$ । ତେବେ ଏକପାତ ସମୀକରଣ ସମୂହ $A^8 \begin{bmatrix} x \\ y \end{bmatrix} = \begin{bmatrix} 8 \\ 64 \end{bmatrix}$ ର ଅଛି :

Options :

8643511531. ସମାଧାନ ନାହିଁ

8643511532. ଏକ ଅନନ୍ୟ ସମାଧାନ

8643511533. ଅସୀମ(ଅନେକ) ସମାଧାନ

8643511534. ଠିକ୍ ଦୁଇଗୋଟି ସମାଧାନ

Question Number : 62 Question Id : 864351512 Question Type : MCQ Option Shuffling : Yes Is Question Mandatory : No

Correct Marks : 4 Wrong Marks : 1

Let the functions $f: \mathbb{R} \rightarrow \mathbb{R}$ and $g: \mathbb{R} \rightarrow \mathbb{R}$ be defined as :

$$f(x) = \begin{cases} x + 2, & x < 0 \\ x^2, & x \geq 0 \end{cases} \text{ and } g(x) = \begin{cases} x^3, & x < 1 \\ 3x - 2, & x \geq 1 \end{cases}$$

Then, the number of points in \mathbb{R} where $(fog)(x)$ is NOT differentiable is equal to :

Options :

8643511535. 0

8643511536. 1

8643511537. 2

8643511538. 3

Question Number : 62 Question Id : 864351512 Question Type : MCQ Option Shuffling : Yes Is Question Mandatory : No

Correct Marks : 4 Wrong Marks : 1

ମନେକର ଫଳନ $f: \mathbb{R} \rightarrow \mathbb{R}$ ଏବଂ $g: \mathbb{R} \rightarrow \mathbb{R}$ ଗୁଡ଼ିକୁ $f(x) = \begin{cases} x + 2, & x < 0 \\ x^2, & x \geq 0 \end{cases}$ ଏବଂ

$$g(x) = \begin{cases} x^3, & x < 1 \\ 3x - 2, & x \geq 1 \end{cases}$$

ଭାବେ ପରିଭାଷିତ କରାଯାଇଛି । ତେବେ ଫଳନ $(fog)(x)$ ଚି ଅବକଳନୀୟ ହେଉନଥିବା

ବାସ୍ତବ ବିନ୍ଦୁମାନଙ୍କର ସଂଖ୍ୟା ସମାନ :

Options :

8643511535. 0

8643511536. 1

8643511537. 2

8643511538. 3

Question Number : 63 Question Id : 864351513 Question Type : MCQ Option Shuffling : Yes Is Question Mandatory : No

Correct Marks : 4 Wrong Marks : 1

Let P be a plane $lx + my + nz = 0$ containing the line, $\frac{1-x}{1} = \frac{y+4}{2} = \frac{z+2}{3}$. If plane P divides the line segment AB joining points A(-3, -6, 1) and B(2, 4, -3) in ratio k : 1 then the value of k is equal to :

Options :

8643511539. 2

8643511540. 1.5

8643511541. 3

8643511542. 4

Question Number : 63 Question Id : 864351513 Question Type : MCQ Option Shuffling : Yes Is Question Mandatory : No

Correct Marks : 4 Wrong Marks : 1

ମନେକର $lx + my + nz = 0$ ଏକ ସମତଳ P, ଯାହା ଉପରେ $\frac{1-x}{1} = \frac{y+4}{2} = \frac{z+2}{3}$ ଏକ ରେଖା । ଯଦି ସମତଳ P, ବିନ୍ଦୁ A(-3, -6, 1) ଏବଂ ବିନ୍ଦୁ B(2, 4, -3) କୁ ଯୋଗକରୁଥିବା ରେଖାଖଣ୍ଡ AB କୁ k : 1 ଅନୁପାତରେ ଛେଦ କରେ, ତେବେ k ର ମୂଲ୍ୟ ସମାଜ :

Options :

8643511539. 2

8643511540. 1.5

8643511541. 3

8643511542. 4

Question Number : 64 Question Id : 864351514 Question Type : MCQ Option Shuffling : Yes Is Question Mandatory : No

Correct Marks : 4 Wrong Marks : 1

If for $a > 0$, the feet of perpendiculars from the points $A(a, -2a, 3)$ and $B(0, 4, 5)$ on the plane $lx + my + nz = 0$ are points $C(0, -a, -1)$ and D respectively, then the length of line segment CD is equal to :

Options :

8643511543. $\sqrt{31}$

8643511544. $\sqrt{66}$

8643511545. $\sqrt{41}$

8643511546. $\sqrt{55}$

Question Number : 64 Question Id : 864351514 Question Type : MCQ Option Shuffling : Yes Is Question Mandatory : No

Correct Marks : 4 Wrong Marks : 1

ଯଦି ($a > 0$ ପାଇଁ) $lx + my + nz = 0$ ସମତଳ ଉପରେ, ବିନ୍ଦୁ $A(a, -2a, 3)$ ଏବଂ ବିନ୍ଦୁ $B(0, 4, 5)$ ଠାରୁ ଅଙ୍କିତ ଲମ୍ବମାନଙ୍କର ପାଦବିନ୍ଦୁ ଯଥାକ୍ରମେ $C(0, -a, -1)$ ଏବଂ D ହୁଏ, ତେବେ ରେଖାଖଣ୍ଡ CD ର ଦୈର୍ଘ୍ୟ ସମାନ :

Options :

8643511543. $\sqrt{31}$

8643511544. $\sqrt{66}$

8643511545. $\sqrt{41}$

8643511546. $\sqrt{55}$

Question Number : 65 Question Id : 864351515 Question Type : MCQ Option Shuffling : Yes Is Question Mandatory : No

Correct Marks : 4 Wrong Marks : 1

Consider three observations a , b and c such that $b = a + c$. If the standard deviation of $a + 2$, $b + 2$, $c + 2$ is d , then which of the following is true ?

Options :

8643511547. $b^2 = 3(a^2 + c^2) - 9d^2$

8643511548. $b^2 = 3(a^2 + c^2) + 9d^2$

8643511549. $b^2 = a^2 + c^2 + 3d^2$

8643511550. $b^2 = 3(a^2 + c^2 + d^2)$

Question Number : 65 Question Id : 864351515 Question Type : MCQ Option Shuffling : Yes Is Question Mandatory : No

Correct Marks : 4 Wrong Marks : 1

ତିନିଗୋଟି ପର୍ଯ୍ୟବେକ୍ଷଣ a, b ଏବଂ c କୁ ବିଚାର କର ଯେପରିକି $b = a + c$ । ଯଦି $a + 2, b + 2, c + 2$ ର ସାଧାରଣ ବିଚ୍ୟୁତି (ସ୍ଵାଭାବିକ ତେଜିଏସନ) d ଅଟେ, ତେବେ ନିମ୍ନଲିଖିତ କେଉଁଟି ସତ ?

Options :

8643511547. $b^2 = 3(a^2 + c^2) - 9d^2$

8643511548. $b^2 = 3(a^2 + c^2) + 9d^2$

8643511549. $b^2 = a^2 + c^2 + 3d^2$

8643511550. $b^2 = 3(a^2 + c^2 + d^2)$

Question Number : 66 Question Id : 864351516 Question Type : MCQ Option Shuffling : Yes Is Question Mandatory : No

Correct Marks : 4 Wrong Marks : 1

Let the position vectors of two points P and Q be $3\hat{i} - \hat{j} + 2\hat{k}$ and $\hat{i} + 2\hat{j} - 4\hat{k}$,

respectively. Let R and S be two points such that the direction ratios of lines PR and QS are

$(4, -1, 2)$ and $(-2, 1, -2)$, respectively. Let lines PR and QS intersect at T. If the

vector \vec{TA} is perpendicular to both \vec{PR} and \vec{QS} and the length of vector \vec{TA} is $\sqrt{5}$ units,

then the modulus of a position vector of A is :

Options :

8643511551. $\sqrt{5}$

8643511552. $\sqrt{171}$

8643511553. $\sqrt{227}$

8643511554. $\sqrt{482}$

Question Number : 66 Question Id : 864351516 Question Type : MCQ Option Shuffling : Yes Is Question Mandatory : No

Correct Marks : 4 Wrong Marks : 1

ମନେକର ଦୁଇଟି ବିନ୍ଦୁ P ଏବଂ Q ର ଭିତ୍ତି ଦିଶାଙ୍କ (P.V) ଯଥାକ୍ରମେ $3\hat{i} - \hat{j} + 2\hat{k}$ ଏବଂ $\hat{i} + 2\hat{j} - 4\hat{k}$ । R ଏବଂ S ଦୁଇଟି ବିନ୍ଦୁ ଯେପରିକି ରେଖା PR ଏବଂ ରେଖା QS ର ଦିଶାୟ ଅନୁପାତ (d.r.) ଯଥାକ୍ରମେ $(4, -1, 2)$ ଏବଂ $(-2, 1, -2)$ । ମନେକର ରେଖା PR ଏବଂ QS, T ବିନ୍ଦୁରେ ଛେଦ କରନ୍ତି । ଯଦି ଦିଶାଙ୍କ \vec{TA} ଉଭୟ ଦିଶାଙ୍କ \vec{PR} ଓ \vec{QS} କୁ ଲମ୍ବ ହୁଅନ୍ତି ଏବଂ ଏହାର ଦୈର୍ଘ୍ୟ $\sqrt{5}$ ଏକକ, ତେବେ ବିନ୍ଦୁ A ର ଭିତ୍ତି ଦିଶାଙ୍କର ପରମମାନ ଅଟେ :

Options :

8643511551. $\sqrt{5}$

8643511552. $\sqrt{171}$

8643511553. $\sqrt{227}$

8643511554. $\sqrt{482}$

Question Number : 67 Question Id : 864351517 Question Type : MCQ Option Shuffling : Yes Is Question Mandatory : No

Correct Marks : 4 Wrong Marks : 1

Let a vector $\alpha\hat{i} + \beta\hat{j}$ be obtained by rotating the vector $\sqrt{3}\hat{i} + \hat{j}$ by an angle 45° about the origin in counterclockwise direction in the first quadrant. Then the area of triangle having vertices (α, β) , $(0, \beta)$ and $(0, 0)$ is equal to :

Options :

8643511555. $\frac{1}{2}$

8643511556. 1

8643511557. $2\sqrt{2}$

8643511558. $\frac{1}{\sqrt{2}}$

Question Number : 67 Question Id : 864351517 Question Type : MCQ Option Shuffling : Yes Is Question Mandatory : No

Correct Marks : 4 Wrong Marks : 1

ପ୍ରଥମ ପାଦରେ, ମୂଳ ବିନ୍ଦୁଠାରେ ଦିଶାଙ୍କ $\sqrt{3}\hat{i} + \hat{j}$ କୁ ଘଣ୍ଟାର ବିପରୀତ ଦିଗରେ 45° ଘୁରାଇଲେ, ଦିଶାଙ୍କ $\alpha\hat{i} + \beta\hat{j}$ ମିଳେ । ତେବେ (α, β) , $(0, \beta)$ ଏବଂ $(0, 0)$ ଶୀର୍ଷବିନ୍ଦୁ ବିଶିଷ୍ଟ ତ୍ରିଭୁଜର କ୍ଷେତ୍ରଫଳ ସମାନ :

Options :

8643511555. $\frac{1}{2}$

8643511556. 1

8643511557. $2\sqrt{2}$

8643511558. $\frac{1}{\sqrt{2}}$

Question Number : 68 Question Id : 864351518 Question Type : MCQ Option Shuffling : Yes Is Question Mandatory : No

Correct Marks : 4 Wrong Marks : 1

The number of roots of the equation,

$$(81)^{\sin^2 x} + (81)^{\cos^2 x} = 30$$

in the interval $[0, \pi]$ is equal to :

Options :

8643511559. 2

8643511560. 3

8643511561. 4

8643511562. 8

Question Number : 68 Question Id : 864351518 Question Type : MCQ Option Shuffling : Yes Is Question Mandatory : No

Correct Marks : 4 Wrong Marks : 1

$[0, \pi]$ ଅନ୍ତରାଳରେ ସମୀକରଣ $(81)^{\sin^2 x} + (81)^{\cos^2 x} = 30$ ର ମୂଳ(ଗଞ୍ଜ) ସଂଖ୍ୟା ସମାନ :

Options :

8643511559. 2

8643511560. 3

8643511561. 4

8643511562. 8

Question Number : 69 Question Id : 864351519 Question Type : MCQ Option Shuffling : Yes Is Question Mandatory : No

Correct Marks : 4 Wrong Marks : 1

A pack of cards has one card missing. Two cards are drawn randomly and are found to be spades. The probability that the missing card is not a spade, is :

Options :

8643511563. $\frac{22}{425}$

8643511564. $\frac{52}{867}$

8643511565. $\frac{39}{50}$

8643511566. $\frac{3}{4}$

Question Number : 69 Question Id : 864351519 Question Type : MCQ Option Shuffling : Yes Is Question Mandatory : No

Correct Marks : 4 Wrong Marks : 1

ଏକ ଡାସ ମୁଠାରେ ଗୋଟିଏ ଡାସ ହଜିଅଛି । ଦୁଇଟି ଡାସ ମନଇଚ୍ଛା ତା ମଧ୍ୟରୁ କାଳି ଦେଖାଗଲା ଯେ ଦୁଇଟି ଚିଡ଼ିଆ (spade) । ହଜିଯାଇଥିବା ଡାସଟି ଏକ ଚିଡ଼ିଆ ନୁହେଁ, ଏହାର ସମ୍ଭାବ୍ୟତା ହେଉଛି :

Options :

8643511563. $\frac{22}{425}$

8643511564. $\frac{52}{867}$

8643511565. $\frac{39}{50}$

8643511566. $\frac{3}{4}$

Question Number : 70 Question Id : 864351520 Question Type : MCQ Option Shuffling : Yes Is Question Mandatory : No

Correct Marks : 4 Wrong Marks : 1

The range of $a \in \mathbb{R}$ for which the function

$f(x) = (4a - 3)(x + \log_e 5) + 2(a - 7) \cot\left(\frac{x}{2}\right) \sin^2\left(\frac{x}{2}\right)$, $x \neq 2n\pi, n \in \mathbb{N}$ has critical points,

is :

Options :

8643511567. $[1, \infty)$

8643511568. $(-\infty, -1]$

8643511569. $\left[-\frac{4}{3}, 2\right]$

8643511570. $(-3, 1)$

Question Number : 70 Question Id : 864351520 Question Type : MCQ Option Shuffling : Yes Is Question Mandatory : No

Correct Marks : 4 Wrong Marks : 1

$a \in \mathbb{R}$ (ବାସ୍ତବ) ର ବିସ୍ତାର, ଯେଉଁଥି ପାଇଁ ଫଳନ $f(x) = (4a - 3)(x + \log_e 5) + 2(a - 7) \cot\left(\frac{x}{2}\right) \sin^2\left(\frac{x}{2}\right)$,

$x \neq 2n\pi, n \in \mathbb{N}$ ର କ୍ରାନ୍ତୀୟ ବିନ୍ଦୁ ରହିଛି, ତାହା ଅଟେ :

Options :

8643511567. $[1, \infty)$

8643511568. $(-\infty, -1]$

8643511569. $\left[-\frac{4}{3}, 2\right]$

8643511570. $(-3, 1)$

Question Number : 71 Question Id : 864351521 Question Type : MCQ Option Shuffling : Yes Is Question Mandatory : No

Correct Marks : 4 Wrong Marks : 1

If n is the number of irrational terms in the expansion of $(3^{1/4} + 5^{1/8})^{60}$, then $(n - 1)$ is divisible by :

Options :

8643511571. 30

8643511572. 8

8643511573. 26

8643511574. 7

Question Number : 71 Question Id : 864351521 Question Type : MCQ Option Shuffling : Yes Is Question Mandatory : No

Correct Marks : 4 Wrong Marks : 1

$(3^{1/4} + 5^{1/8})^{60}$ ର ପ୍ରସାରଣରେ, ଅପରିମେୟ ପଦମାନଙ୍କର ସଂଖ୍ୟା ଯଦି n ହୁଏ, ତେବେ $(n - 1)$ ବିଭାଜ୍ୟ ହୋଇପାରୁଥିବା

ସଂଖ୍ୟାଟି :

Options :

8643511571. 30

8643511572. 8

8643511573. 26

8643511574. 7

Question Number : 72 Question Id : 864351522 Question Type : MCQ Option Shuffling : Yes Is Question Mandatory : No

Correct Marks : 4 Wrong Marks : 1

Let $[x]$ denote greatest integer less than or equal to x . If for $n \in \mathbb{N}$,

$$(1 - x + x^3)^n = \sum_{j=0}^{3n} a_j x^j, \text{ then}$$

$$\sum_{j=0}^{\left[\frac{3n}{2}\right]} a_{2j} + 4 \sum_{j=0}^{\left[\frac{3n-1}{2}\right]} a_{2j+1} \text{ is equal to :}$$

Options :

8643511575. 2^{n-1}

8643511576. n

8643511577. 2

8643511578. 1

Question Number : 72 Question Id : 864351522 Question Type : MCQ Option Shuffling : Yes Is Question Mandatory : No

Correct Marks : 4 Wrong Marks : 1

ମନେକର $[x]$ ସୂଚାଏ ସର୍ବାଧିକ ପୂର୍ଣ୍ଣସଂଖ୍ୟା x ଠାରୁ ସାନ ବା x ସହ ସମାନ । ଯଦି $n \in \mathbb{N}$ ପାଇଁ

$$(1 - x + x^3)^n = \sum_{j=0}^{3n} a_j x^j, \text{ ତେବେ } \sum_{j=0}^{\left[\frac{3n}{2}\right]} a_{2j} + 4 \sum_{j=0}^{\left[\frac{3n-1}{2}\right]} a_{2j+1} \text{ ସମାନ :}$$

Options :

8643511575. 2^{n-1}

8643511576. n

8643511577. 2

8643511578. 1

Question Number : 73 Question Id : 864351523 Question Type : MCQ Option Shuffling : Yes Is Question Mandatory : No

Correct Marks : 4 Wrong Marks : 1

Which of the following Boolean expression is a tautology ?

Options :

8643511579. $(p \wedge q) \vee (p \vee q)$

8643511580. $(p \wedge q) \vee (p \rightarrow q)$

8643511581. $(p \wedge q) \wedge (p \rightarrow q)$

8643511582. $(p \wedge q) \rightarrow (p \rightarrow q)$

Question Number : 73 Question Id : 864351523 Question Type : MCQ Option Shuffling : Yes Is Question Mandatory : No

Correct Marks : 4 Wrong Marks : 1

ନିମ୍ନ କେଉଁ ବୁଲିଆନ୍ ଉକ୍ତଟି ଏକ ପୁନରୁକ୍ତି (ଟଟୋଲୋଜି) ?

Options :

8643511579. $(p \wedge q) \vee (p \vee q)$

8643511580. $(p \wedge q) \vee (p \rightarrow q)$

8643511581. $(p \wedge q) \wedge (p \rightarrow q)$

8643511582. $(p \wedge q) \rightarrow (p \rightarrow q)$

Question Number : 74 Question Id : 864351524 Question Type : MCQ Option Shuffling : Yes Is Question Mandatory : No

Correct Marks : 4 Wrong Marks : 1

Let $S_k = \sum_{r=1}^k \tan^{-1} \left(\frac{6^r}{2^{2r+1} + 3^{2r+1}} \right)$. Then $\lim_{k \rightarrow \infty} S_k$ is equal to :

Options :

8643511583. $\frac{\pi}{2}$

8643511584. $\cot^{-1}\left(\frac{3}{2}\right)$

8643511585. $\tan^{-1}\left(\frac{3}{2}\right)$

8643511586. $\tan^{-1}(3)$

Question Number : 74 Question Id : 864351524 Question Type : MCQ Option Shuffling : Yes Is Question Mandatory : No

Correct Marks : 4 Wrong Marks : 1

ମନେକର $S_k = \sum_{r=1}^k \tan^{-1}\left(\frac{6^r}{2^{2r+1} + 3^{2r+1}}\right)$ । ଶେଷର $\lim_{k \rightarrow \infty} S_k$ ର ମାନ :

Options :

8643511583. $\frac{\pi}{2}$

8643511584. $\cot^{-1}\left(\frac{3}{2}\right)$

8643511585. $\tan^{-1}\left(\frac{3}{2}\right)$

8643511586. $\tan^{-1}(3)$

Question Number : 75 Question Id : 864351525 Question Type : MCQ Option Shuffling : Yes Is Question Mandatory : No

Correct Marks : 4 Wrong Marks : 1

The number of elements in the set $\{x \in \mathbb{R} : (|x| - 3)|x + 4| = 6\}$ is equal to :

Options :

8643511587. 1

8643511588. 2

8643511589. 3

8643511590. 4

Question Number : 75 Question Id : 864351525 Question Type : MCQ Option Shuffling : Yes Is Question Mandatory : No

Correct Marks : 4 Wrong Marks : 1

ସେଇ $\{x \in \mathbb{R} : (|x| - 3) |x + 4| = 6\}$ ରେ ଉପାଦାନ ସଂଖ୍ୟା ସମାନ :

Options :

8643511587. 1

8643511588. 2

8643511589. 3

8643511590. 4

Question Number : 76 Question Id : 864351526 Question Type : MCQ Option Shuffling : Yes Is Question Mandatory : No

Correct Marks : 4 Wrong Marks : 1

If for $x \in \left(0, \frac{\pi}{2}\right)$, $\log_{10} \sin x + \log_{10} \cos x = -1$ and $\log_{10}(\sin x + \cos x) = \frac{1}{2}(\log_{10} n - 1)$, $n > 0$,

then the value of n is equal to :

Options :

8643511591. 9

8643511592. 12

8643511593. 16

8643511594. 20

Question Number : 76 Question Id : 864351526 Question Type : MCQ Option Shuffling : Yes Is Question Mandatory : No

Correct Marks : 4 Wrong Marks : 1

ଯଦି $x \in \left(0, \frac{\pi}{2}\right)$ ପାଇଁ, $\log_{10} \sin x + \log_{10} \cos x = -1$ ଏବଂ $\log_{10}(\sin x + \cos x) = \frac{1}{2}(\log_{10} n - 1)$, $n > 0$,

ତେବେ n ର ମୂଲ୍ୟ ସମାନ :

Options :

8643511591. 9

8643511592. 12

8643511593. 16

8643511594. 20

Question Number : 77 Question Id : 864351527 Question Type : MCQ Option Shuffling : Yes Is Question Mandatory : No

Correct Marks : 4 Wrong Marks : 1

If $y = y(x)$ is the solution of the differential equation, $\frac{dy}{dx} + 2y \tan x = \sin x$, $y\left(\frac{\pi}{3}\right) = 0$, then

the maximum value of the function $y(x)$ over \mathbb{R} is equal to :

Options :

8643511595. 8

8643511596. $\frac{1}{2}$

8643511597. $-\frac{15}{4}$

8643511598. $\frac{1}{8}$

Question Number : 77 Question Id : 864351527 Question Type : MCQ Option Shuffling : Yes Is Question Mandatory : No

Correct Marks : 4 Wrong Marks : 1

ଯଦି $y = y(x)$, $\frac{dy}{dx} + 2y \tan x = \sin x$, $y\left(\frac{\pi}{3}\right) = 0$, ଅବକଳ ସମୀକରଣର ସମାଧାନ ଅଟେ, ତେବେ ଫଳନ $y(x)$

ର ସର୍ବାଧିକ ବାସ୍ତବ ମୂଲ୍ୟ ସମାନ :

Options :

8643511595. $\frac{8}{8}$

8643511596. $\frac{1}{2}$

8643511597. $-\frac{15}{4}$

8643511598. $\frac{1}{8}$

Question Number : 78 Question Id : 864351528 Question Type : MCQ Option Shuffling : Yes Is Question Mandatory : No

Correct Marks : 4 Wrong Marks : 1

The locus of the midpoints of the chord of the circle, $x^2 + y^2 = 25$ which is tangent to the

hyperbola, $\frac{x^2}{9} - \frac{y^2}{16} = 1$ is :

Options :

8643511599. $(x^2 + y^2)^2 - 9x^2 + 144y^2 = 0$

8643511600. $(x^2 + y^2)^2 - 9x^2 - 16y^2 = 0$

8643511601. $(x^2 + y^2)^2 - 9x^2 + 16y^2 = 0$

8643511602. $(x^2 + y^2)^2 - 16x^2 + 9y^2 = 0$

Question Number : 78 Question Id : 864351528 Question Type : MCQ Option Shuffling : Yes Is Question Mandatory : No

Correct Marks : 4 Wrong Marks : 1

$x^2 + y^2 = 25$ ବୃତ୍ତର ଜ୍ୟା ମାନକର ମଧ୍ୟବିନ୍ଦୁମାନକର ସଂଚାର ପଥ, ଯାହା $\frac{x^2}{9} - \frac{y^2}{16} = 1$ ହାଇପରବୋଲା (ଜ୍ୟାମିତିକ

ଅତିପରାବଳୟ କ୍ଷେତ୍ର) ପ୍ରତି ସ୍ପର୍ଶକ, ତାହା ଅଟେ :

Options :

8643511599. $(x^2 + y^2)^2 - 9x^2 + 144y^2 = 0$

8643511600. $(x^2 + y^2)^2 - 9x^2 - 16y^2 = 0$

8643511601. $(x^2 + y^2)^2 - 9x^2 + 16y^2 = 0$

8643511602. $(x^2 + y^2)^2 - 16x^2 + 9y^2 = 0$

Question Number : 79 Question Id : 864351529 Question Type : MCQ Option Shuffling : Yes Is Question Mandatory : No

Correct Marks : 4 Wrong Marks : 1

If the three normals drawn to the parabola, $y^2 = 2x$ pass through the point $(a, 0)$ $a \neq 0$, then 'a' must be greater than :

Options :

8643511603. 1

8643511604. -1

8643511605. $\frac{1}{2}$

8643511606. $-\frac{1}{2}$

Question Number : 79 Question Id : 864351529 Question Type : MCQ Option Shuffling : Yes Is Question Mandatory : No

Correct Marks : 4 Wrong Marks : 1

ଯଦି $y^2 = 2x$ ପାରାବୋଲା (ପରିବୃତ୍ତ) ପ୍ରତି ଅଙ୍କିତ ତିନିଗୋଟି ଲମ୍ବ ବିନ୍ଦୁ $(a, 0)$ $a \neq 0$, ମଧ୍ୟ ଦେଇ ଗତି କରେ, ତେବେ 'a' ର ମାନ ନିଶ୍ଚିତ ଭାବରେ (କାହାଠାରୁ) ବଡ଼ :

Options :

8643511603. 1

8643511604. -1

8643511605. $\frac{1}{2}$

8643511606. $-\frac{1}{2}$

Question Number : 80 Question Id : 864351530 Question Type : MCQ Option Shuffling : Yes Is Question Mandatory : No

Correct Marks : 4 Wrong Marks : 1

Let a complex number z , $|z| \neq 1$, satisfy $\log_{\frac{1}{\sqrt{2}}} \left(\frac{|z| + 11}{(|z| - 1)^2} \right) \leq 2$. Then, the largest value of

$|z|$ is equal to _____.

Options :

8643511607. 5

8643511608. 6

8643511609. 7

8643511610. 8

Question Number : 80 Question Id : 864351530 Question Type : MCQ Option Shuffling : Yes Is Question Mandatory : No

Correct Marks : 4 Wrong Marks : 1

ମନେକର z ଏକ ମିଶ୍ର ସଂଖ୍ୟା (କମ୍ପ୍ଲେକ୍ସ ସଂଖ୍ୟା), $|z| \neq 1$, ଯାହା $\log_{\frac{1}{\sqrt{2}}} \left(\frac{|z| + 11}{(|z| - 1)^2} \right) \leq 2$, ସର୍ତ୍ତକୁ ସିଦ୍ଧ କରେ ।

ତେବେ $|z|$ ର ସର୍ବାଧିକ ମୂଲ୍ୟ ସମାନ :

Options :

8643511607. 5

8643511608. 6

8643511609. 7

8643511610. 8

Section Id :	86435136
Section Number :	6
Section type :	Online
Mandatory or Optional :	Mandatory
Number of Questions :	10
Number of Questions to be attempted :	5
Section Marks :	20
Mark As Answered Required? :	Yes
Sub-Section Number :	1
Sub-Section Id :	86435136
Question Shuffling Allowed :	Yes

Question Number : 81 Question Id : 864351531 Question Type : SA
Correct Marks : 4 Wrong Marks : 0

Let z and w be two complex numbers such that $w = z\bar{z} - 2z + 2$, $\left| \frac{z+i}{z-3i} \right| = 1$ and $\text{Re}(w)$ has minimum value. Then, the minimum value of $n \in \mathbb{N}$ for which w^n is real, is equal to _____.

Response Type : Numeric
Evaluation Required For SA : Yes
Show Word Count : Yes
Answers Type : Equal
Text Areas : PlainText
Possible Answers :

100

Question Number : 81 Question Id : 864351531 Question Type : SA
Correct Marks : 4 Wrong Marks : 0

ମନେକର z ଏବଂ w ଦୁଇଟି ମିଶ୍ର (କମ୍ପ୍ଲେକ୍ସ) ସଂଖ୍ୟା ଯେପରିକି $w = z\bar{z} - 2z + 2$, $\left| \frac{z+i}{z-3i} \right| = 1$ ଏବଂ $\text{Re}(w)$ ର ଏକ ସର୍ବନିମ୍ନ ମୂଲ୍ୟ ଅଛି । ତେବେ $n \in \mathbb{N}$ ର ସର୍ବନିମ୍ନ ମୂଲ୍ୟ, ଯେଉଁଥି ପାଇଁ w^n ବାସ୍ତବ ହେବ, ତାହା ସମାନ _____ ।

Response Type : Numeric
Evaluation Required For SA : Yes
Show Word Count : Yes
Answers Type : Equal
Text Areas : PlainText
Possible Answers :

100

Question Number : 82 Question Id : 864351532 Question Type : SA
Correct Marks : 4 Wrong Marks : 0

Let $f: \mathbb{R} \rightarrow \mathbb{R}$ be a continuous function such that $f(x) + f(x+1) = 2$, for all $x \in \mathbb{R}$. If $I_1 = \int_0^8 f(x) dx$ and $I_2 = \int_{-1}^3 f(x) dx$, then the value of $I_1 + 2I_2$ is equal to _____.

Response Type : Numeric

Evaluation Required For SA : Yes

Show Word Count : Yes

Answers Type : Equal

Text Areas : PlainText

Possible Answers :

100

Question Number : 82 **Question Id :** 864351532 **Question Type :** SA

Correct Marks : 4 **Wrong Marks :** 0

ମନେକର $f: \mathbb{R} \rightarrow \mathbb{R}$ ଏକ ଅବିଚ୍ଛିନ୍ନ ଫଳନ ଯେପରିକି $f(x) + f(x+1) = 2$, $x \in \mathbb{R}$ ର ସମସ୍ତ ବାସ୍ତବ ମୂଲ୍ୟ ପାଇଁ । ଯଦି

$I_1 = \int_0^8 f(x) dx$ ଏବଂ $I_2 = \int_{-1}^3 f(x) dx$, ତେବେ $I_1 + 2I_2$ ର ମୂଲ୍ୟ ସମାନ _____ ।

Response Type : Numeric

Evaluation Required For SA : Yes

Show Word Count : Yes

Answers Type : Equal

Text Areas : PlainText

Possible Answers :

100

Question Number : 83 **Question Id :** 864351533 **Question Type :** SA

Correct Marks : 4 **Wrong Marks :** 0

If the normal to the curve $y(x) = \int_0^x (2t^2 - 15t + 10) dt$ at a point (a, b) is parallel to the line

$x + 3y = -5$, $a > 1$, then the value of $|a + 6b|$ is equal to _____.

Response Type : Numeric

Evaluation Required For SA : Yes

Show Word Count : Yes

Answers Type : Equal

Text Areas : PlainText

Possible Answers :

100

Question Number : 83 Question Id : 864351533 Question Type : SA

Correct Marks : 4 Wrong Marks : 0

ଯଦି ବିନ୍ଦୁ (a, b) ଠାରେ ବକ୍ରରେଖା $y(x) = \int_0^x (2t^2 - 15t + 10) dt$ ପ୍ରତି ଅଙ୍କିତ ଲମ୍ବ, ସରଳରେଖା $x + 3y = -5$,

$a > 1$ ସହ ସମାନ୍ତର ହୁଏ, ତେବେ $|a + 6b|$ ର ମୂଲ୍ୟ ସମାନ _____ ।

Response Type : Numeric

Evaluation Required For SA : Yes

Show Word Count : Yes

Answers Type : Equal

Text Areas : PlainText

Possible Answers :

100

Question Number : 84 Question Id : 864351534 Question Type : SA

Correct Marks : 4 Wrong Marks : 0

If $\lim_{x \rightarrow 0} \frac{ae^x - b\cos x + ce^{-x}}{x \sin x} = 2$, then $a + b + c$ is equal to _____.

Response Type : Numeric

Evaluation Required For SA : Yes

Show Word Count : Yes

Answers Type : Equal

Text Areas : PlainText

Possible Answers :

100

Question Number : 84 Question Id : 864351534 Question Type : SA

Correct Marks : 4 Wrong Marks : 0

ଯଦି $\lim_{x \rightarrow 0} \frac{ae^x - b\cos x + ce^{-x}}{x \sin x} = 2$ । ତେବେ $a + b + c$ ସମାନ _____ ।

Response Type : Numeric

Evaluation Required For SA : Yes

Show Word Count : Yes

Answers Type : Equal

Text Areas : PlainText

Possible Answers :

100

Question Number : 85 Question Id : 864351535 Question Type : SA

Correct Marks : 4 Wrong Marks : 0

Consider an arithmetic series and a geometric series having four initial terms from the set {11, 8, 21, 16, 26, 32, 4}. If the last terms of these series are the maximum possible four digit numbers, then the number of common terms in these two series is equal to _____.

Response Type : Numeric

Evaluation Required For SA : Yes

Show Word Count : Yes

Answers Type : Equal

Text Areas : PlainText

Possible Answers :

100

Question Number : 85 **Question Id :** 864351535 **Question Type :** SA

Correct Marks : 4 **Wrong Marks :** 0

ସେଟ {11, 8, 21, 16, 26, 32, 4} ମଧ୍ୟରୁ ଚାରିଗୋଟି ପ୍ରାରମ୍ଭିକ ପଦ ନେଇ ଗୋଟିଏ ଗଣିତିକ ଶ୍ରେଣୀ ଓ ଗୁଣୋତ୍ତର ଶ୍ରେଣୀ କୁ ବିଚାର କର । ଯଦି ଏହି ଶ୍ରେଣୀ(ପ୍ରଗତି) ଗୁଡ଼ିକର ଶେଷ ପଦଗୁଡ଼ିକ ସର୍ବାଧିକ ସମ୍ଭବ ଚାରିଅଙ୍କ ବିଶିଷ୍ଟ ସଂଖ୍ୟା ହୋଇଥାଏ, ତେବେ ଏହି ଦୁଇଟି ଶ୍ରେଣୀ ମଧ୍ୟରେ ଥିବା ସାଧାରଣ ପଦମାନଙ୍କର ସଂଖ୍ୟା ସମାନ _____ ।

Response Type : Numeric

Evaluation Required For SA : Yes

Show Word Count : Yes

Answers Type : Equal

Text Areas : PlainText

Possible Answers :

100

Question Number : 86 **Question Id :** 864351536 **Question Type :** SA

Correct Marks : 4 **Wrong Marks :** 0

Let $P = \begin{bmatrix} -30 & 20 & 56 \\ 90 & 140 & 112 \\ 120 & 60 & 14 \end{bmatrix}$ and $A = \begin{bmatrix} 2 & 7 & \omega^2 \\ -1 & -\omega & 1 \\ 0 & -\omega & -\omega+1 \end{bmatrix}$ where $\omega = \frac{-1 + i\sqrt{3}}{2}$, and I_3 be the

identity matrix of order 3. If the determinant of the matrix $(P^{-1}AP - I_3)^2$ is $\alpha\omega^2$, then the value of α is equal to _____.

Response Type : Numeric

Evaluation Required For SA : Yes

Show Word Count : Yes

Answers Type : Equal

Text Areas : PlainText

Possible Answers :

100

Question Number : 86 Question Id : 864351536 Question Type : SA

Correct Marks : 4 Wrong Marks : 0

ମନେକର $P = \begin{bmatrix} -30 & 20 & 56 \\ 90 & 140 & 112 \\ 120 & 60 & 14 \end{bmatrix}$ ଏବଂ $A = \begin{bmatrix} 2 & 7 & \omega^2 \\ -1 & -\omega & 1 \\ 0 & -\omega & -\omega+1 \end{bmatrix}$, ଯେଉଁଠାରେ $\omega = \frac{-1 + i\sqrt{3}}{2}$, ଏବଂ

I_3 ହେଉଛି 3 ଅର୍ଡର ବିଶିଷ୍ଟ ଏକ (ଆଇଡେଣ୍ଟି) ମାଟ୍ରିକ୍ସ (ସାରଣୀ) । ଯଦି $(P^{-1}AP - I_3)^2$ ମାଟ୍ରିକ୍ସର ଡିଟରମିନାଣ୍ଟ ମୂଲ୍ୟ $\alpha\omega^2$ ହୁଏ, ତେବେ α ର ମୂଲ୍ୟ ସମାନ _____ ।

Response Type : Numeric

Evaluation Required For SA : Yes

Show Word Count : Yes

Answers Type : Equal

Text Areas : PlainText

Possible Answers :

100

Question Number : 87 Question Id : 864351537 Question Type : SA

Correct Marks : 4 Wrong Marks : 0

Let $f: (0, 2) \rightarrow \mathbb{R}$ be defined as $f(x) = \log_2 \left(1 + \tan \left(\frac{\pi x}{4} \right) \right)$.

Then, $\lim_{n \rightarrow \infty} \frac{2}{n} \left(f \left(\frac{1}{n} \right) + f \left(\frac{2}{n} \right) + \dots + f(1) \right)$ is equal to _____.

Response Type : Numeric

Evaluation Required For SA : Yes

Show Word Count : Yes

Answers Type : Equal

Text Areas : PlainText

Possible Answers :

100

Question Number : 87 Question Id : 864351537 Question Type : SA

Correct Marks : 4 Wrong Marks : 0

ମନେକର $f: (0, 2) \rightarrow \mathbb{R}$ ଫଙ୍କ୍ସନ୍‌ଟିକୁ $f(x) = \log_2 \left(1 + \tan \left(\frac{\pi x}{4} \right) \right)$ ରୂପେ ପରିଭାଷିତ କରାଗଲା । ତେବେ

$\lim_{n \rightarrow \infty} \frac{2}{n} \left(f \left(\frac{1}{n} \right) + f \left(\frac{2}{n} \right) + \dots + f(1) \right)$ ସମାନ _____ ।

Response Type : Numeric

Evaluation Required For SA : Yes

Show Word Count : Yes

Answers Type : Equal

Text Areas : PlainText

Possible Answers :

100

Question Number : 88 Question Id : 864351538 Question Type : SA

Correct Marks : 4 Wrong Marks : 0

The total number of 3×3 matrices A having entries from the set $\{0, 1, 2, 3\}$ such that the sum of all the diagonal entries of AA^T is 9, is equal to _____.

Response Type : Numeric

Evaluation Required For SA : Yes

Show Word Count : Yes

Answers Type : Equal

Text Areas : PlainText

Possible Answers :

100

Question Number : 88 Question Id : 864351538 Question Type : SA

Correct Marks : 4 Wrong Marks : 0

ସେଟ୍ $\{0, 1, 2, 3\}$ ରୁ ଉପାଦାନ ନେଇ (3×3) ଅର୍ଡରର ମାଟ୍ରିକ୍ସ (ସାରଣୀ) ତିଆରି କରିବା ଯେପରିକି AA^T ର ସମସ୍ତ କର୍ଣ୍ଣରେ ଥିବା ଉପାଦାନ ମାନଙ୍କର ମିଶାଣ ଫଳ 9 ହେଉଥିବ, ତେବେ ସେହି (3×3) ଅର୍ଡରର ମାଟ୍ରିକ୍ସ ମାନଙ୍କର ସଂଖ୍ୟା ସମାନ _____।

Response Type : Numeric

Evaluation Required For SA : Yes

Show Word Count : Yes

Answers Type : Equal

Text Areas : PlainText

Possible Answers :

100

Question Number : 89 Question Id : 864351539 Question Type : SA

Correct Marks : 4 Wrong Marks : 0

Let ABCD be a square of side of unit length. Let a circle C_1 centered at A with unit radius is drawn. Another circle C_2 which touches C_1 and the lines AD and AB are tangent to it, is also drawn. Let a tangent line from the point C to the circle C_2 meet the side AB at E. If the length of EB is $\alpha + \sqrt{3} \beta$, where α, β are integers, then $\alpha + \beta$ is equal to _____.

Response Type : Numeric

Evaluation Required For SA : Yes

Show Word Count : Yes

Answers Type : Equal

Text Areas : PlainText

Possible Answers :

100

Question Number : 89 Question Id : 864351539 Question Type : SA

Correct Marks : 4 Wrong Marks : 0

ମନେକର 1 ଏକକ ଲମ୍ବ ବାହୁ ବିଶିଷ୍ଟ ABCD ଏକ ବର୍ଗକ୍ଷେତ୍ର । ବିନ୍ଦୁ A ଠାରେ କେନ୍ଦ୍ର କରି, 1 ଏକକ ବ୍ୟାସାର୍ଦ୍ଧ ବିଶିଷ୍ଟ C_1 ବୃତ୍ତ ଅଙ୍କନ କରାଯାଇଛି । C_1 କୁ ସ୍ପର୍ଶକରି ଅନ୍ୟ ଏକ ବୃତ୍ତ C_2 ଅଙ୍କନ କରାଯାଇଛି ଯାହା ପ୍ରତି ରେଖା AD ଓ AB ସ୍ପର୍ଶକ ଅଟନ୍ତି । ମନେକର C ବିନ୍ଦୁରୁ C_2 ବୃତ୍ତ ପ୍ରତି ଏକ ସ୍ପର୍ଶକ ରେଖା ଚିତ୍ରିତ ଯାହା AB ପାର୍ଶ୍ୱକୁ E ବିନ୍ଦୁରେ ସ୍ପର୍ଶ କଲା । ଯଦି EB ର ଦୈର୍ଘ୍ୟ $\alpha + \sqrt{3} \beta$, (ଯେଉଁଠାରେ α, β ପୂର୍ଣ୍ଣସଂଖ୍ୟା), ତେବେ $\alpha + \beta$ ସମାନ _____ ।

Response Type : Numeric

Evaluation Required For SA : Yes

Show Word Count : Yes

Answers Type : Equal

Text Areas : PlainText

Possible Answers :

100

Question Number : 90 Question Id : 864351540 Question Type : SA

Correct Marks : 4 Wrong Marks : 0

Let the curve $y = y(x)$ be the solution of the differential equation, $\frac{dy}{dx} = 2(x + 1)$. If the numerical value of area bounded by the curve $y = y(x)$ and x -axis is $\frac{4\sqrt{8}}{3}$, then the value of $y(1)$ is equal to _____.

Response Type : Numeric

Evaluation Required For SA : Yes

Show Word Count : Yes

Answers Type : Equal

Text Areas : PlainText

Possible Answers :

100

Question Number : 90 Question Id : 864351540 Question Type : SA

Correct Marks : 4 Wrong Marks : 0

ମନେକର $y = y(x)$ ବକ୍ରରେଖା, $\frac{dy}{dx} = 2(x + 1)$ ଅବକଳ ସମୀକରଣଟିର ଏକ ସମାଧାନ ଅଟେ । ଯଦି ବକ୍ରରେଖା

$y = y(x)$ ଏବଂ x -ଅକ୍ଷ ଦ୍ୱାରା ଆବଦ୍ଧ କ୍ଷେତ୍ରର କ୍ଷେତ୍ରଫଳର ସୀମାନ୍ତୀକ ମୂଲ୍ୟ $\frac{4\sqrt{8}}{3}$ ହୁଏ, ତେବେ $y(1)$ ର ମୂଲ୍ୟ ସମାନ

_____।

Response Type : Numeric

Evaluation Required For SA : Yes

Show Word Count : Yes

Answers Type : Equal

Text Areas : PlainText

Possible Answers :

100