

National Testing Agency

Question Paper Name : B TECH EM 16th March 2021 Shift 2
Subject Name : B TECH EM
Creation Date : 2021-03-16 21:03:24
Duration : 180
Number of Questions : 90
Total Marks : 300
Display Marks: Yes

B TECH EM

Group Number : 1
Group Id : 86435118
Group Maximum Duration : 0
Group Minimum Duration : 180
Show Attended Group? : No
Edit Attended Group? : No
Break time : 0
Group Marks : 300
Is this Group for Examiner? : No

Physics Section A

Section Id : 864351103
Section Number : 1
Section type : Online
Mandatory or Optional : Mandatory
Number of Questions : 20
Number of Questions to be attempted : 20
Section Marks : 80
Mark As Answered Required? : Yes
Sub-Section Number : 1
Sub-Section Id : 864351103
Question Shuffling Allowed : Yes

Question Number : 1 Question Id : 8643511531 Question Type : MCQ Option Shuffling : Yes Is Question Mandatory : No Correct Marks : 4 Wrong Marks : 1

Two identical antennas mounted on identical towers are separated from each other by a distance of 45 km. What should nearly be the minimum height of receiving antenna to receive the signals in line of sight ?

(Assume radius of earth is 6400 km)

Options :

8643514591. 79.1 m

8643514592. 39.55 m

8643514593. 158.2 m

8643514594. 19.77 m

Question Number : 1 Question Id : 8643511531 Question Type : MCQ Option Shuffling : Yes Is Question Mandatory : No

Correct Marks : 4 Wrong Marks : 1

दोन एकसारखे अँटेना एकसारख्या टॉवरवर ठेवले असून ते एकमेकांपासून 45 km अंतराने वेगळे केले आहेत. दृष्टी रेषेतील संकेत ग्रहण करण्यासाठी ग्राही अँटेनाची कमीत कमी उंची जवळजवळ किती असू शकेल?

(पृथ्वीची त्रिज्या 6400 km माना)

Options :

8643514591. 79.1 m

8643514592. 39.55 m

8643514593. 158.2 m

8643514594. 19.77 m

Question Number : 2 Question Id : 8643511532 Question Type : MCQ Option Shuffling : Yes Is Question Mandatory : No

Correct Marks : 4 Wrong Marks : 1

The de-Broglie wavelength associated with an electron and a proton were calculated by accelerating them through same potential of 100 V. What should nearly be the ratio of their wavelengths ? ($m_p = 1.00727u$ $m_e = 0.00055u$)

Options :

8643514595. 43 : 1

8643514596. 1860 : 1

8643514597. 41.4 : 1

8643514598. $(1860)^2 : 1$

Question Number : 2 Question Id : 8643511532 Question Type : MCQ Option Shuffling : Yes Is

Question Mandatory : No

Correct Marks : 4 Wrong Marks : 1

इलेक्ट्रॉन व प्रोटॉन संबंधित डि-ब्रोगीली तरंगलांबी काढली, जेव्हा ते सारख्याच 100 V विभवाने त्वरित केले. त्यांच्या तरंगलांबीचे गुणोत्तर जवळपास किती असू शकेल? ($m_p = 1.00727u$ $m_e = 0.00055u$)

Options :

8643514595. 43 : 1

8643514596. 1860 : 1

8643514597. 41.4 : 1

8643514598. $(1860)^2 : 1$

Question Number : 3 Question Id : 8643511533 Question Type : MCQ Option Shuffling : Yes Is

Question Mandatory : No

Correct Marks : 4 Wrong Marks : 1

The refractive index of a converging lens is 1.4. What will be the focal length of this lens if it is placed in a medium of same refractive index ? Assume the radii of curvature of the faces of lens are R_1 and R_2 respectively.

Options :

8643514599. Zero

8643514600. 1

8643514601. Infinite

$$\frac{R_1 R_2}{R_1 - R_2}$$

8643514602.

Question Number : 3 Question Id : 8643511533 Question Type : MCQ Option Shuffling : Yes Is Question Mandatory : No

Correct Marks : 4 Wrong Marks : 1

एका अभिसारी भिंगाचा अपवर्तनांक 1.4 आहे. जर ते तेवढ्याच अपवर्तनांक असलेल्या माध्यमात ठेवले तर त्या भिंगाची नाभीय लांबी किती असू शकेल? असे माना कि भिंगाच्या पृष्ठभागाची वक्रता त्रिज्या अनुक्रमे R_1 व R_2 आहे.

Options :

8643514599. शून्य

8643514600. 1

8643514601. अनंत

$$\frac{R_1 R_2}{R_1 - R_2}$$

8643514602.

Question Number : 4 Question Id : 8643511534 Question Type : MCQ Option Shuffling : Yes Is Question Mandatory : No

Correct Marks : 4 Wrong Marks : 1

Red light differs from blue light as they have :

Options :

8643514603. Same frequencies and same wavelengths

8643514604. Different frequencies and different wavelengths

8643514605. Same frequencies and different wavelengths

8643514606. Different frequencies and same wavelengths

Question Number : 4 Question Id : 8643511534 Question Type : MCQ Option Shuffling : Yes Is Question Mandatory : No

Correct Marks : 4 Wrong Marks : 1

लाल प्रकाश निळ्या प्रकाशापासून वेगळ आहे कारण त्यांच्याकडे _____ आहे.

Options :

8643514603. सारख्या वारंवारिता व सारख्या तरंगलांबी
8643514604. वेगळ्या वारंवारिता व वेगळ्या तरंगलांबी
8643514605. सारख्या वारंवारिता व वेगळ्या तरंगलांबी
8643514606. वेगळ्या वारंवारिता व सारख्या तरंगलांबी

Question Number : 5 Question Id : 8643511535 Question Type : MCQ Option Shuffling : Yes Is Question Mandatory : No

Correct Marks : 4 Wrong Marks : 1

The magnetic field in a region is given by $\vec{B} = B_0 \left(\frac{x}{a}\right) \hat{k}$. A square loop of side d is placed with its edges along the x and y axes. The loop is moved with a constant velocity $\vec{v} = v_0 \hat{i}$.

The emf induced in the loop is :

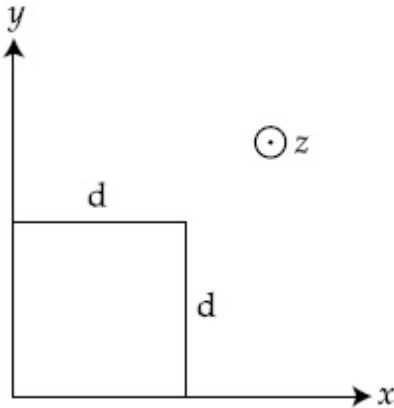

Options :

8643514607. $\frac{B_0 v_0 d}{2a}$
8643514608. $\frac{B_0 v_0 d^2}{a}$
8643514609. $\frac{B_0 v_0^2 d}{2a}$

$$\frac{B_0 v_0 d^2}{2a}$$

8643514610.

Question Number : 5 Question Id : 8643511535 Question Type : MCQ Option Shuffling : Yes Is Question Mandatory : No

Correct Marks : 4 Wrong Marks : 1

एका भागातील चुंबकीय क्षेत्र $\vec{B} = B_0 \left(\frac{x}{a}\right)\hat{k}$ असे दिले आहे. d बाजू असलेले लूप x व y अक्षावर बाजू रहातील असे ठेवले आहे. लूप $\vec{v} = v_0 \hat{i}$ स्थिर वेगाने गतिमान केले आहे. लूपमध्ये प्रवर्तित विद्युत गामक बल _____ आहे.

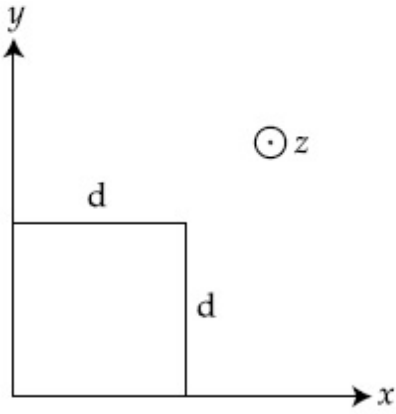

Options :

$$\frac{B_0 v_0 d}{2a}$$

8643514607.

$$\frac{B_0 v_0 d^2}{a}$$

8643514608.

$$\frac{B_0 v_0^2 d}{2a}$$

8643514609.

$$\frac{B_0 v_0 d^2}{2a}$$

8643514610.

Question Number : 6 Question Id : 8643511536 Question Type : MCQ Option Shuffling : Yes Is Question Mandatory : No

Correct Marks : 4 Wrong Marks : 1

Amplitude of a mass-spring system, which is executing simple harmonic motion decreases with time. If mass = 500g, Decay constant = 20 g/s then how much time is required for the amplitude of the system to drop to half of its initial value ?

($\ln 2 = 0.693$)

Options :

8643514611. 34.65 s

8643514612. 15.01 s

8643514613. 0.034 s

8643514614. 17.32 s

Question Number : 6 Question Id : 8643511536 Question Type : MCQ Option Shuffling : Yes Is Question Mandatory : No

Correct Marks : 4 Wrong Marks : 1

वस्तुमान-स्प्रिंग संहतीत, जी सरल आवर्त गतीत आहे तिचा आयाम वेळेबरोबर कमी होतो. संहतीचा आयाम सुरुवातीच्या मुल्याच्या अर्ध्यापर्यंत खाली येण्यासाठी किती वेळ लागेल?

(वस्तुमान = 500 g, ऱ्हासाचा स्थिरांक = 20 g/s, $\ln 2 = 0.693$ घ्या)

Options :

8643514611. 34.65 s

8643514612. 15.01 s

8643514613. 0.034 s

8643514614. 17.32 s

Question Number : 7 Question Id : 8643511537 Question Type : MCQ Option Shuffling : Yes Is Question Mandatory : No

Correct Marks : 4 Wrong Marks : 1

Calculate the value of mean free path (λ) for oxygen molecules at temperature 27°C and pressure 1.01×10^5 Pa. Assume the molecular diameter 0.3 nm and the gas is ideal. ($k = 1.38 \times 10^{-23}$ JK⁻¹)

Options :

8643514615. 32 nm

8643514616. 58 nm

8643514617. 86 nm

8643514618. 102 nm

Question Number : 7 Question Id : 8643511537 Question Type : MCQ Option Shuffling : Yes Is Question Mandatory : No

Correct Marks : 4 Wrong Marks : 1

27°C तापमानास व 1.01×10^5 Pa दाबास ऑक्सीजन रेणूसाठी सरासरी मुक्त पथाचे (λ) मूल्य काढा. माना कि रेणूचा व्यास 0.3 nm आहे व वायू आदर्श आहे. ($k = 1.38 \times 10^{-23} \text{ JK}^{-1}$)

Options :

8643514615. 32 nm

8643514616. 58 nm

8643514617. 86 nm

8643514618. 102 nm

Question Number : 8 Question Id : 8643511538 Question Type : MCQ Option Shuffling : Yes Is Question Mandatory : No

Correct Marks : 4 Wrong Marks : 1

What will be the nature of flow of water from a circular tap, when its flow rate increased from 0.18 L/min to 0.48 L/min ? The radius of the tap and viscosity of water are 0.5 cm and 10^{-3} Pa s, respectively.

(Density of water : 10^3 kg/m^3)

Options :

8643514619. Steady flow to unsteady flow

8643514620. Unsteady to steady flow

8643514621. Remains steady flow

8643514622. Remains turbulent flow

Question Number : 8 Question Id : 8643511538 Question Type : MCQ Option Shuffling : Yes Is Question Mandatory : No

Correct Marks : 4 Wrong Marks : 1

गोलाकार तोटीतून पाण्याच्या प्रवाहाचे स्वरूप कसे असेल जेव्हा प्रवाहाचा दर 0.18 L/min पासून 0.48 L/min पर्यंत वाढतो. त्रिज्या व पाण्याची विष्यंदिता अनुक्रमे 0.5 cm व 10^{-3} Pa s आहे.

(पाण्याची घनता : 10^3 kg/m³)

Options :

8643514619. स्थिर प्रवाह ते अस्थिर प्रवाह

8643514620. अस्थिर ते स्थिर प्रवाह

8643514621. स्थिर प्रवाह रहातो

8643514622. क्षुब्ध प्रवाह रहातो

Question Number : 9 Question Id : 8643511539 Question Type : MCQ Option Shuffling : Yes Is Question Mandatory : No

Correct Marks : 4 Wrong Marks : 1

A charge Q is moving $d\vec{l}$ distance in the magnetic field \vec{B} . Find the value of work done by \vec{B} .

Options :

8643514623. 1

8643514624. Zero

8643514625. Infinite

8643514626. -1

Question Number : 9 Question Id : 8643511539 Question Type : MCQ Option Shuffling : Yes Is Question Mandatory : No

Correct Marks : 4 Wrong Marks : 1

Q प्रभार \vec{B} चुंबकीय क्षेत्रात $d\vec{l}$ अंतर जात आहे. \vec{B} ने केलेल्या कार्याचे मूल्य काढा.

Options :

8643514623. 1

8643514624. शून्य

8643514625. अनंत

8643514626. -1

Question Number : 10 Question Id : 8643511540 Question Type : MCQ Option Shuffling : Yes Is Question Mandatory : No

Correct Marks : 4 Wrong Marks : 1

Calculate the time interval between 33% decay and 67% decay if half-life of a substance is 20 minutes.

Options :

8643514627. 20 minutes

8643514628. 40 minutes

8643514629. 60 minutes

8643514630. 13 minutes

Question Number : 10 Question Id : 8643511540 Question Type : MCQ Option Shuffling : Yes Is Question Mandatory : No

Correct Marks : 4 Wrong Marks : 1

जर पदार्थाचा अर्धायुकाल 20 मिनिटे आहे. तर 33% ऱ्हास व 67% ऱ्हास यामधील वेळेतील फरक काढा.

Options :

8643514627. 20 मिनिटे

8643514628. 40 मिनिटे

8643514629. 60 मिनिटे

8643514630. 13 मिनिटे

Question Number : 11 Question Id : 8643511541 Question Type : MCQ Option Shuffling : Yes Is Question Mandatory : No

Correct Marks : 4 Wrong Marks : 1

For the given circuit, comment on the type of transformer used.

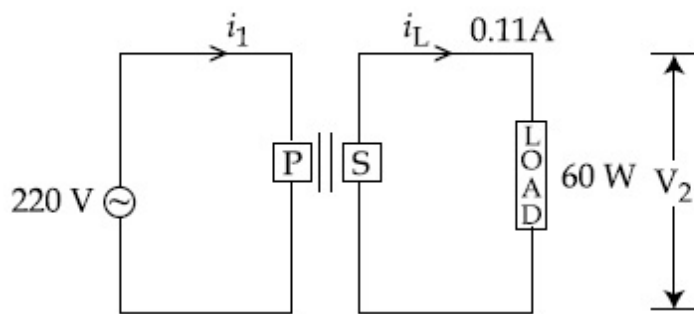

Options :

8643514631. Step - up transformer

8643514632. Step down transformer

8643514633. Auto transformer

8643514634. Auxilliary transformer

Question Number : 11 Question Id : 8643511541 Question Type : MCQ Option Shuffling : Yes Is Question Mandatory : No

Correct Marks : 4 Wrong Marks : 1

दिलेल्या परिपथासाठी, वापरलेल्या परिवर्तीत्राच्या प्रकारासंबंधी प्रतिक्रिया द्या.

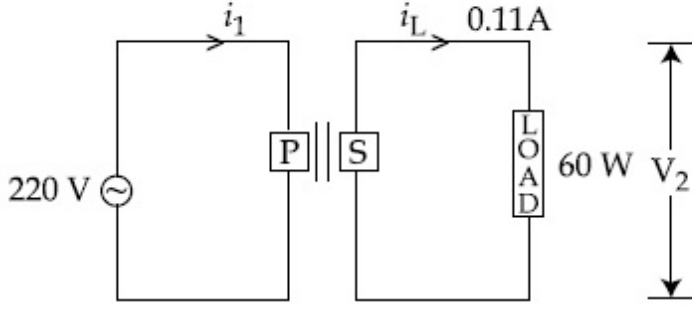

Options :

8643514631. उत्परिवर्तित्र
8643514632. अवपरिवर्तित्र
8643514633. स्वयंपरिवर्तित्र
8643514634. सहाय्यकारी परिवर्तित्र

Question Number : 12 Question Id : 8643511542 Question Type : MCQ Option Shuffling : Yes Is Question Mandatory : No

Correct Marks : 4 Wrong Marks : 1

The half-life of Au^{198} is 2.7 days. The activity of 1.50 mg of Au^{198} if its atomic weight is 198 g mol^{-1} is, ($N_A = 6 \times 10^{23}/\text{mol}$).

Options :

8643514635. 240 Ci
8643514636. 357 Ci
8643514637. 252 Ci
8643514638. 535 Ci

Question Number : 12 Question Id : 8643511542 Question Type : MCQ Option Shuffling : Yes Is Question Mandatory : No

Correct Marks : 4 Wrong Marks : 1

Au^{198} चा अर्धायु काल 2.7 दिवस आहे. 1.50 mg Au^{198} ची सक्रियता, जर त्याचे अण्विक वजन 198 g mol^{-1} आहे, _____ . ($N_A = 6 \times 10^{23} / \text{mol}$)

Options :

8643514635. ^{240}Ci

8643514636. ^{357}Ci

8643514637. ^{252}Ci

8643514638. ^{535}Ci

Question Number : 13 Question Id : 8643511543 Question Type : MCQ Option Shuffling : Yes Is Question Mandatory : No

Correct Marks : 4 Wrong Marks : 1

A bimetallic strip consists of metals A and B. It is mounted rigidly as shown. The metal A has higher coefficient of expansion compared to that of metal B. When the bimetallic strip is placed in a cold bath, it will :

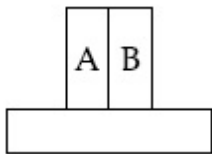

Options :

8643514639. Bend towards the right

8643514640. Bend towards the left

8643514641. Not bend but shrink

8643514642. Neither bend nor shrink

Question Number : 13 Question Id : 8643511543 Question Type : MCQ Option Shuffling : Yes Is Question Mandatory : No

Correct Marks : 4 Wrong Marks : 1

एका द्विधातुच्या पट्टीत A व B धातू आहेत. दाखविल्याप्रमाणे ते घट्ट ठेवलेले आहेत. A धातूचा प्रसरण गुणांक B धातूपेक्षा जास्त आहे. जेव्हा द्विधातुची पट्टी थंड भांड्यात ठेवली, ती

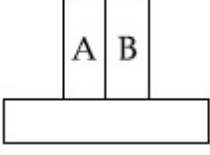

Options :

8643514639. उजव्या बाजूस वाकेल

8643514640. डाव्या बाजूस वाकेल

8643514641. वाकणार नाही पण आकसेल

8643514642. वाकणार नाही व आकसणार नाही

Question Number : 14 Question Id : 8643511544 Question Type : MCQ Option Shuffling : Yes Is Question Mandatory : No

Correct Marks : 4 Wrong Marks : 1

A large block of wood of mass $M = 5.99 \text{ kg}$ is hanging from two long massless cords. A bullet of mass $m = 10 \text{ g}$ is fired into the block and gets embedded in it. The (block + bullet) then swing upwards, their centre of mass rising a vertical distance $h = 9.8 \text{ cm}$ before the (block + bullet) pendulum comes momentarily to rest at the end of its arc. The speed of the bullet just before collision is :

(take $g = 9.8 \text{ ms}^{-2}$)

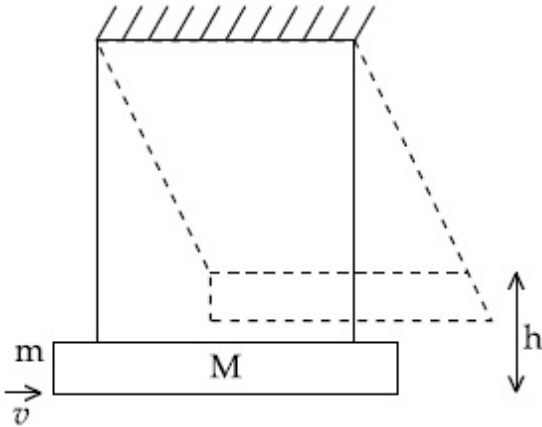

Options :

8643514643. 811.4 m/s

8643514644. 821.4 m/s

8643514645. 831.4 m/s

8643514646. 841.4 m/s

Question Number : 14 Question Id : 8643511544 Question Type : MCQ Option Shuffling : Yes Is Question Mandatory : No

Correct Marks : 4 Wrong Marks : 1

दोन लांब वजनविरहित दोऱ्यांपासून $M=5.99$ kg वस्तुमानाचा लाकडाचा मोठा ठोकळा लोंबत आहे. $m=10$ g वस्तुमानाची गोळी ठोकळ्यात झाडली व ती त्याच्यात एम्बेड होते नंतर (ठोकळा + गोळी) वरील दिशेत दोलते, चापाच्या शेवटच्या टोकावर (ठोकळा + गोळी) दोलक तात्पुरता स्थिर होण्यापूर्वी, वस्तुकेंद्र $h=9.8$ cm उभे अंतर वर जातो. गोळीचा वेग नुकताच संघात होण्यापूर्वी _____ आहे.

(घ्या $g=9.8$ ms⁻²)

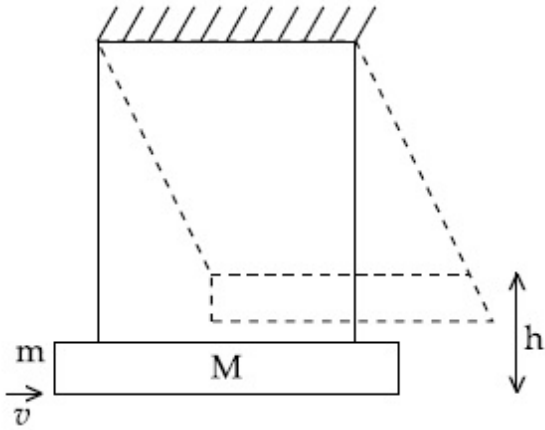

Options :

8643514643. 811.4 m/s

8643514644. 821.4 m/s

8643514645. 831.4 m/s

8643514646. 841.4 m/s

Question Number : 15 Question Id : 8643511545 Question Type : MCQ Option Shuffling : Yes Is Question Mandatory : No

Correct Marks : 4 Wrong Marks : 1

Statement I : A cyclist is moving on an unbanked road with a speed of 7 kmh^{-1} and takes a sharp circular turn along a path of radius of 2m without reducing the speed. The static friction coefficient is 0.2 . The cyclist will not slip and pass the curve. ($g = 9.8 \text{ m/s}^2$)

Statement II : If the road is banked at an angle of 45° , cyclist can cross the curve of 2m radius with the speed of 18.5 kmh^{-1} without slipping.

In the light of the above statements, choose the correct answer from the options given below.

Options :

8643514647. Both statement I and statement II are true

8643514648. Both statement I and statement II are false

8643514649. Statement I is correct and statement II is incorrect

8643514650. Statement I is incorrect and statement II is correct

Question Number : 15 Question Id : 8643511545 Question Type : MCQ Option Shuffling : Yes Is Question Mandatory : No

Correct Marks : 4 Wrong Marks : 1

विधान I : एक सायकलवाला न वाकविलेल्या रस्त्यावरून 7 kmh^{-1} वेगाने जात आहे व वेग कमी न करता 2 m त्रिज्या असलेल्या रस्त्यावरून तीव्र गोलाकार वळण घेतो. स्थितिक घर्षण गुणांक 0.2 आहे. सायकलवाला घसरत नाही व वळण पार करतो. ($g = 9.8 \text{ m/s}^2$)

विधान II : जर रस्ता 45° कोनातून वाकविला, सायकलवाला न घसरता 18.5 kmh^{-1} वेगाने 2 m त्रिज्या असलेला वक्र रस्ता पार करतो.

वरील विधानांसंदर्भात, खाली दिलेल्या पर्यायांतून योग्य उत्तर निवडा.

Options :

8643514647. विधान I व विधान II दोन्ही खरी आहेत.

8643514648. विधान I व विधान II दोन्ही खोटी आहेत.

8643514649. विधान I बरोबर आहे व विधान II चूक आहे.

8643514650. विधान I चूक आहे व विधान II बरोबर आहे.

Question Number : 16 Question Id : 8643511546 Question Type : MCQ Option Shuffling : Yes Is Question Mandatory : No

Correct Marks : 4 Wrong Marks : 1

A mosquito is moving with a velocity $\vec{v} = 0.5 t^2 \hat{i} + 3t \hat{j} + 9 \hat{k}$ m/s and accelerating in uniform conditions. What will be the direction of mosquito after 2 s ?

Options :

8643514651. $\tan^{-1}\left(\frac{5}{2}\right)$ from x -axis

8643514652. $\tan^{-1}\left(\frac{5}{2}\right)$ from y -axis

8643514653. $\tan^{-1}\left(\frac{2}{3}\right)$ from x -axis

8643514654. $\tan^{-1}\left(\frac{2}{3}\right)$ from y -axis

Question Number : 16 Question Id : 8643511546 Question Type : MCQ Option Shuffling : Yes Is Question Mandatory : No

Correct Marks : 4 Wrong Marks : 1

एक माशी $\vec{v} = 0.5 t^2 \hat{i} + 3t \hat{j} + 9 \hat{k}$ m/s वेगाने गतिमान आहे व एकसमान अटींवर त्वरणित आहे. दोन सेकंदानंतर माशीची दिशा कोणती असेल?

Options :

8643514651. x -अक्षापासून $\tan^{-1}\left(\frac{5}{2}\right)$

8643514652. y -अक्षापासून $\tan^{-1}\left(\frac{5}{2}\right)$

8643514653. x -अक्षापासून $\tan^{-1}\left(\frac{2}{3}\right)$

8643514654. y -अक्षापासून $\tan^{-1}\left(\frac{2}{3}\right)$

Question Number : 17 Question Id : 8643511547 Question Type : MCQ Option Shuffling : Yes Is

Question Mandatory : No

Correct Marks : 4 Wrong Marks : 1

In order to determine the Young's Modulus of a wire of radius 0.2 cm (measured using a scale of least count=0.001 cm) and length 1m (measured using a scale of least count=1 mm), a weight of mass 1 kg (measured using a scale of least count=1 g) was hanged to get the elongation of 0.5 cm (measured using a scale of least count 0.001 cm). What will be the fractional error in the value of Young's Modulus determined by this experiment ?

Options :

8643514655. 1.4 %

8643514656. 0.9%

8643514657. 0.14%

8643514658. 9%

Question Number : 17 Question Id : 8643511547 Question Type : MCQ Option Shuffling : Yes Is

Question Mandatory : No

Correct Marks : 4 Wrong Marks : 1

0.2 cm त्रिज्या (श्रेणीचे लघुत्तम माप=0.001 cm वापरून मोजली) व 1 m लांबीच्या (श्रेणीचे लघुत्तम माप= 1 mm वापरून मोजली) तारेचा यंगचा मापांक मोजण्यासाठी 1 kg चे वजन (श्रेणीचे लघुत्तम माप=1 g) टांगले तेव्हा लांबीतील वाढ 0.5 cm (श्रेणीचे लघुत्तम माप=0.001 cm वापरून मोजली) मिळाली. ह्या प्रयोगामुळे यंगचा मापांक मोजण्याच्या मुल्यातील अपूर्णाकातील चूक किती असेल?

Options :

8643514655. 1.4 %

8643514656. 0.9%

8643514657. 0.14%

8643514658. 9%

Question Number : 18 Question Id : 8643511548 Question Type : MCQ Option Shuffling : Yes Is Question Mandatory : No

Correct Marks : 4 Wrong Marks : 1

A resistor develops 500 J of thermal energy in 20 s when a current of 1.5A is passed through it. If the current is increased from 1.5 A to 3 A, what will be the energy developed in 20 s.

Options :

8643514659. 500 J

8643514660. 1000 J

8643514661. 1500 J

8643514662. 2000 J

Question Number : 18 Question Id : 8643511548 Question Type : MCQ Option Shuffling : Yes Is Question Mandatory : No

Correct Marks : 4 Wrong Marks : 1

एक रोध 20 सेकंदात 500 J एवढी औष्णिक ऊर्जा तयार करतो जेव्हा त्यातून 1.5A धारा वाहते. जर धारा 1.5A पासून 3A पर्यंत वाढविली, तर 20 सेकंदात किती ऊर्जा तयार होईल?

Options :

8643514659. 500 J

8643514660. 1000 J

8643514661. 1500 J

8643514662. 2000 J

Question Number : 19 Question Id : 8643511549 Question Type : MCQ Option Shuffling : Yes Is Question Mandatory : No

Correct Marks : 4 Wrong Marks : 1

Find out the surface charge density at the intersection of point $x=3$ m plane and x -axis, in the region of uniform line charge of 8 nC/m lying along the z -axis in free space.

Options :

8643514663. 47.88 C/m

8643514664. 0.07 nC m⁻²

8643514665. 0.424 nC m⁻²

8643514666. 4.0 nC m⁻²

Question Number : 19 Question Id : 8643511549 Question Type : MCQ Option Shuffling : Yes Is Question Mandatory : No Correct Marks : 4 Wrong Marks : 1

मुक्त वातावरणात, $x = 3$ m बिंदुच्या पृष्ठभागावरील प्रभार घनता काढा. z -अक्षावरील भागात एकसमान रेखीय प्रभार 8 nC/m आहे.

Options :

8643514663. 47.88 C/m

8643514664. 0.07 nC m⁻²

8643514665. 0.424 nC m⁻²

8643514666. 4.0 nC m⁻²

Question Number : 20 Question Id : 8643511550 Question Type : MCQ Option Shuffling : Yes Is Question Mandatory : No Correct Marks : 4 Wrong Marks : 1

The following logic gate is equivalent to :

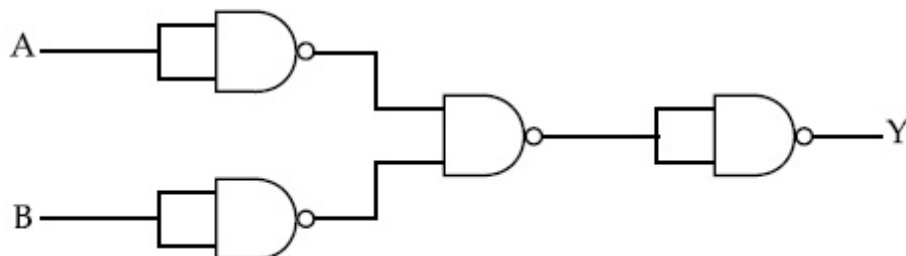

Options :

8643514667. AND Gate

8643514668. NAND Gate

8643514669. OR Gate

8643514670. NOR Gate

Question Number : 20 Question Id : 8643511550 Question Type : MCQ Option Shuffling : Yes Is Question Mandatory : No

Correct Marks : 4 Wrong Marks : 1

खालील लॉजिक द्वार _____ बरोबर एकसमान आहे.

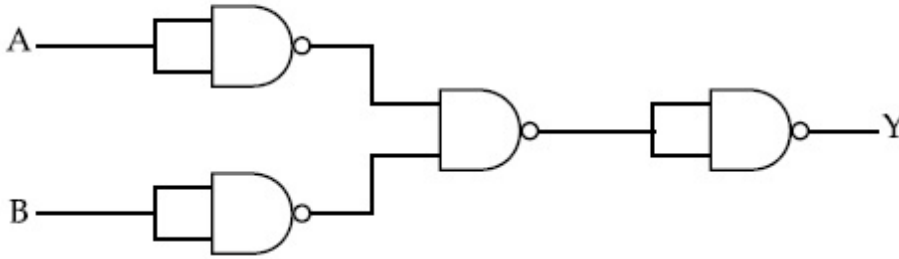

Options :

8643514667. AND द्वार

8643514668. NAND द्वार

8643514669. OR द्वार

8643514670. NOR द्वार

Physics Section B

Section Id :	864351104
Section Number :	2
Section type :	Online
Mandatory or Optional :	Mandatory
Number of Questions :	10
Number of Questions to be attempted :	5
Section Marks :	20
Mark As Answered Required? :	Yes

Sub-Section Number : 1
Sub-Section Id : 864351104
Question Shuffling Allowed : Yes

Question Number : 21 Question Id : 8643511551 Question Type : SA
Correct Marks : 4 Wrong Marks : 0

If one wants to remove all the mass of the earth to infinity in order to break it up completely.

The amount of energy that needs to be supplied will be $\frac{x}{5} \frac{GM^2}{R}$ where x is _____

(Round off to the Nearest Integer)

(M is the mass of earth, R is the radius of earth, G is the gravitational constant)

Response Type : Numeric
Evaluation Required For SA : Yes
Show Word Count : Yes
Answers Type : Equal
Text Areas : PlainText
Possible Answers :
100

Question Number : 21 Question Id : 8643511551 Question Type : SA
Correct Marks : 4 Wrong Marks : 0

जर एखाद्यास पृथ्वीचे सर्व वस्तुमान काढून अनंतापर्यंत, पूर्णपणे तोडण्यासाठी पाहिजे आहे. त्यासाठी पुरविण्यात

आलेली ऊर्जा $\frac{x}{5} \frac{GM^2}{R}$ असेल जेथे $x =$ _____ आहे. (जवळच्या पूर्णांकापर्यंत)

(M हे पृथ्वीचे वस्तुमान, R ही पृथ्वीची त्रिज्या, G हा गुरुत्वीय स्थिरांक आहे.)

Response Type : Numeric
Evaluation Required For SA : Yes
Show Word Count : Yes
Answers Type : Equal
Text Areas : PlainText
Possible Answers :
100

Question Number : 22 Question Id : 8643511552 Question Type : SA
Correct Marks : 4 Wrong Marks : 0

A swimmer can swim with velocity of 12 km/h in still water. Water flowing in a river has velocity 6 km/h. The direction with respect to the direction of flow of river water he should swim in order to reach the point on the other bank just opposite to his starting point is _____°. (Round off to the Nearest Integer)

(Find the angle in degrees)

Response Type : Numeric

Evaluation Required For SA : Yes

Show Word Count : Yes

Answers Type : Equal

Text Areas : PlainText

Possible Answers :

100

Question Number : 22 Question Id : 8643511552 Question Type : SA

Correct Marks : 4 Wrong Marks : 0

पोहणारा 12 km/h वेगाने पोहतो जेथे नदीतील पाण्याचा प्रवाहाचा वेग 6 km/h आहे. त्याने असे पोहावे कि ज्यामुळे नदीच्या पाण्याच्या प्रवाहाच्या दिशेशी _____° दिशेत तो पोहोचेल जो बिंदू सुरुवातीच्या बिंदूपासून नुकत्याच विरुद्ध तिरावरील बिंदू आहे. (जवळपासच्या पूर्णांकापर्यंत)

(डिग्रीजमध्ये कोन शोधा)

Response Type : Numeric

Evaluation Required For SA : Yes

Show Word Count : Yes

Answers Type : Equal

Text Areas : PlainText

Possible Answers :

100

Question Number : 23 Question Id : 8643511553 Question Type : SA

Correct Marks : 4 Wrong Marks : 0

A body of mass 2 kg moves under a force of $(2\hat{i} + 3\hat{j} + 5\hat{k})$ N. It starts from rest and was at the origin initially. After 4 s, its new coordinates are (8, b, 20). The value of b is _____.

(Round off to the Nearest Integer)

Response Type : Numeric

Evaluation Required For SA : Yes

Show Word Count : Yes

Answers Type : Equal

Text Areas : PlainText

Possible Answers :

100

Question Number : 23 Question Id : 8643511553 Question Type : SA

Correct Marks : 4 Wrong Marks : 0

2 kg वस्तुमानाची वस्तु $(2\hat{i} + 3\hat{j} + 5\hat{k})N$ बलाने गतिमान आहे. ती स्थिरतेपासून जाते व सुरुवातीस आरंभावर आहे. 4 सेकंदानंतर, तिचे नवीन सहनिर्देशांक $(8, b, 20)$ आहेत. b चे मूल्य _____ आहे. (जवळपासच्या पूर्णांकापर्यंत)

Response Type : Numeric

Evaluation Required For SA : Yes

Show Word Count : Yes

Answers Type : Equal

Text Areas : PlainText

Possible Answers :

100

Question Number : 24 Question Id : 8643511554 Question Type : SA

Correct Marks : 4 Wrong Marks : 0

A force $\vec{F} = 4\hat{i} + 3\hat{j} + 4\hat{k}$ is applied on an intersection point of $x = 2$ plane and x -axis. The magnitude of torque of this force about a point $(2, 3, 4)$ is _____. (Round off to the Nearest Integer)

Response Type : Numeric

Evaluation Required For SA : Yes

Show Word Count : Yes

Answers Type : Equal

Text Areas : PlainText

Possible Answers :

100

Question Number : 24 Question Id : 8643511554 Question Type : SA

Correct Marks : 4 Wrong Marks : 0

x -अक्ष व $x = 2$ प्रतलाच्या काटछेदावरील बिंदूवर $\vec{F} = 4\hat{i} + 3\hat{j} + 4\hat{k}$ बल लावले आहे. ह्या बलाची $(2, 3, 4)$ बिंदूभोवती आघूर्णाची किंमत _____ आहे. (जवळच्या पूर्णांकापर्यंत)

Response Type : Numeric

Evaluation Required For SA : Yes

Show Word Count : Yes

Answers Type : Equal

Text Areas : PlainText

Possible Answers :

100

Question Number : 25 Question Id : 8643511555 Question Type : SA

Correct Marks : 4 Wrong Marks : 0

A solid disc of radius 'a' and mass 'm' rolls down without slipping on an inclined plane making an angle θ with the horizontal. The acceleration of the disc will be $\frac{2}{b} g \sin\theta$ where

b is _____. (Round off to the Nearest Integer)

(g = acceleration due to gravity

θ = angle as shown in figure)

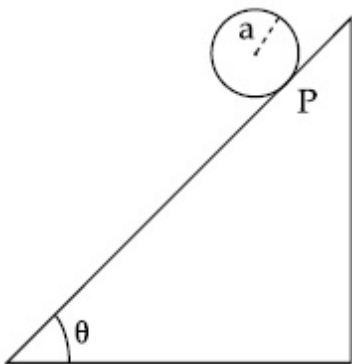

Response Type : Numeric

Evaluation Required For SA : Yes

Show Word Count : Yes

Answers Type : Equal

Text Areas : PlainText

Possible Answers :

100

Question Number : 25 Question Id : 8643511555 Question Type : SA

Correct Marks : 4 Wrong Marks : 0

'a' त्रिज्या व 'm' वस्तुमानाची भरीव तबकडी क्षितिजसमांतरशी θ कोन केलेल्या आनत प्रतलावरून न घसरता गडगडत खाली येत आहे. तबकडीचे त्वरण $\frac{2}{b} g \sin\theta$ असेल जेथे $b = \underline{\hspace{2cm}}$ आहे. (जवळच्या पूर्णांकापर्यंत)

($g =$ गुरुत्वीय त्वरण, $\theta =$ आकृतीत दाखविल्याप्रमाणे कोन)

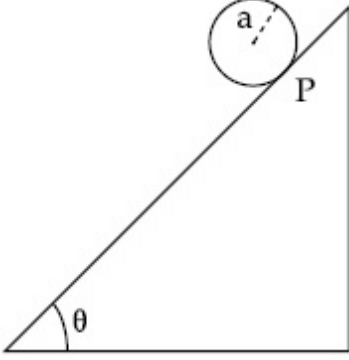

Response Type : Numeric

Evaluation Required For SA : Yes

Show Word Count : Yes

Answers Type : Equal

Text Areas : PlainText

Possible Answers :

100

Question Number : 26 **Question Id :** 8643511556 **Question Type :** SA

Correct Marks : 4 **Wrong Marks :** 0

For an ideal heat engine, the temperature of the source is 127°C . In order to have 60% efficiency the temperature of the sink should be $\underline{\hspace{2cm}}$ $^\circ\text{C}$. (Round off to the Nearest Integer)

Response Type : Numeric

Evaluation Required For SA : Yes

Show Word Count : Yes

Answers Type : Equal

Text Areas : PlainText

Possible Answers :

100

Question Number : 26 **Question Id :** 8643511556 **Question Type :** SA

Correct Marks : 4 **Wrong Marks :** 0

उष्मा अभियंत्रणासाठी, उद्गमाचे तापमान 127°C आहे. 60% कार्यक्षमता असण्यासाठी कुंडाचे तापमान $\underline{\hspace{2cm}}$ $^\circ\text{C}$ असले पाहिजे. (जवळच्या पूर्णांकापर्यंत)

Response Type : Numeric

Evaluation Required For SA : Yes

Show Word Count : Yes

Answers Type : Equal

Text Areas : PlainText

Possible Answers :

100

Question Number : 27 **Question Id :** 8643511557 **Question Type :** SA

Correct Marks : 4 **Wrong Marks :** 0

In a parallel plate capacitor set up, the plate area of capacitor is 2 m^2 and the plates are separated by 1 m . If the space between the plates are filled with a dielectric material of thickness 0.5 m and area 2 m^2 (see fig) the capacitance of the set-up will be _____ ϵ_0 . (Dielectric constant of the material = 3.2) (Round off to the Nearest Integer)

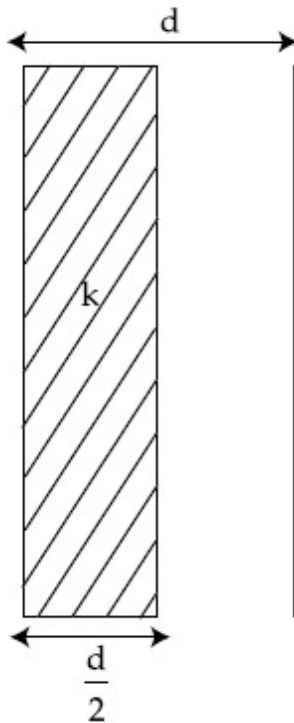

Response Type : Numeric

Evaluation Required For SA : Yes

Show Word Count : Yes

Answers Type : Equal

Text Areas : PlainText

Possible Answers :

100

Question Number : 27 **Question Id :** 8643511557 **Question Type :** SA

Correct Marks : 4 **Wrong Marks :** 0

समांतर पट्टी संधारित्रात, संधारित्राच्या पट्ट्यांचे क्षेत्रफळ 2 m^2 असून पट्ट्यांमधील अंतर 1 m आहे. जर पट्ट्यांमधील जागा 0.5 m जाड आणि 2 m^2 क्षेत्रफळात (आकृती बघा) पराविद्युत पदार्थाने भरली तर धारकता _____ ϵ_0 असेल. (पदार्थाचा पराविद्युत स्थिरांक = 3.2) (जवळच्या पूर्णांकापर्यंत)

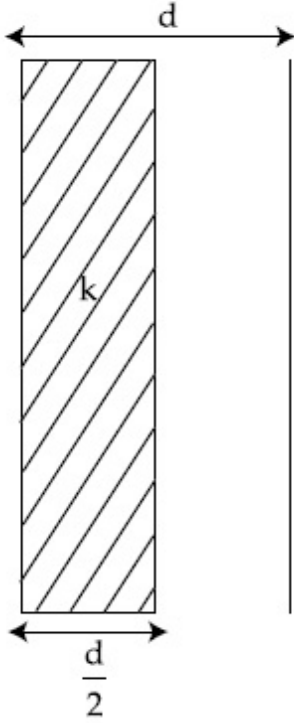

Response Type : Numeric

Evaluation Required For SA : Yes

Show Word Count : Yes

Answers Type : Equal

Text Areas : PlainText

Possible Answers :

100

Question Number : 28 **Question Id :** 8643511558 **Question Type :** SA

Correct Marks : 4 **Wrong Marks :** 0

The energy dissipated by a resistor is 10 mJ in 1 s when an electric current of 2 mA flows through it. The resistance is _____ Ω . (Round off to the Nearest Integer)

Response Type : Numeric

Evaluation Required For SA : Yes

Show Word Count : Yes

Answers Type : Equal

Text Areas : PlainText

Possible Answers :

100

Question Number : 28 **Question Id :** 8643511558 **Question Type :** SA

Correct Marks : 4 Wrong Marks : 0

रोधाने 1 सेकंदात 10 mJ ऊर्जा अपाकृत केली जेव्हा त्यातून 2 mA विद्युत धारा वाहते. रोध _____ Ω आहे. (जवळच्या पूर्णांकापर्यंत)

Response Type : Numeric

Evaluation Required For SA : Yes

Show Word Count : Yes

Answers Type : Equal

Text Areas : PlainText

Possible Answers :

100

Question Number : 29 Question Id : 8643511559 Question Type : SA

Correct Marks : 4 Wrong Marks : 0

A deviation of 2° is produced in the yellow ray when prism of crown and flint glass are achromatically combined. Taking dispersive powers of crown and flint glass as 0.02 and 0.03 respectively and refractive index for yellow light for these glasses are 1.5 and 1.6 respectively. The refracting angles for crown glass prism will be _____ $^\circ$ (in degree). (Round off to the Nearest Integer)

Response Type : Numeric

Evaluation Required For SA : Yes

Show Word Count : Yes

Answers Type : Equal

Text Areas : PlainText

Possible Answers :

100

Question Number : 29 Question Id : 8643511559 Question Type : SA

Correct Marks : 4 Wrong Marks : 0

जेव्हा क्राउन प्रिझम व फ्लिंट प्रिझम अवर्णीपणे जोडले तेव्हा पिवळ्या प्रकाशाचे 2° मधून विचलन होते. क्राउन व फ्लिंट काचेची अपस्करण शक्ती अनुक्रमे 0.02 व 0.03 घेउन व पिवळ्या प्रकाशाचा अपवर्तनांक त्या काचांसाठी अनुक्रमे 1.5 व 1.6 आहे. क्राउन काचेसाठी अपवर्तन कोन _____ असेल. (जवळच्या पूर्णांकापर्यंत)

Response Type : Numeric

Evaluation Required For SA : Yes

Show Word Count : Yes

Answers Type : Equal

Text Areas : PlainText

Possible Answers :

100

Question Number : 30 Question Id : 8643511560 Question Type : SA

Correct Marks : 4 Wrong Marks : 0

A closed organ pipe of length L and an open organ pipe contain gases of densities ρ_1 and ρ_2 respectively. The compressibility of gases are equal in both the pipes. Both the pipes are

vibrating in their first overtone with same frequency. The length of the open pipe is $\frac{x}{3} L \sqrt{\frac{\rho_1}{\rho_2}}$ where x is _____. (Round off to the Nearest Integer)

Response Type : Numeric

Evaluation Required For SA : Yes

Show Word Count : Yes

Answers Type : Equal

Text Areas : PlainText

Possible Answers :

100

Question Number : 30 Question Id : 8643511560 Question Type : SA

Correct Marks : 4 Wrong Marks : 0

L लांबीच्या बंद नळीत व उघड्या नळीत अनुक्रमे ρ_1 व ρ_2 घनतेचा वायू भरलेला आहे. दोन्ही नळ्यांमध्ये वायूची संपीड्यता सारखीच आहे. दोन्ही नळ्या सारख्याच वारंवारतेने त्यांच्या पहिल्या अधिस्वरकात कंपन पावत आहेत.

उघड्या नळीची लांबी $\frac{x}{3} L \sqrt{\frac{\rho_1}{\rho_2}}$ आहे. जेथे $x =$ _____ आहे. (जवळच्या पूर्णांकापर्यंत)

Response Type : Numeric

Evaluation Required For SA : Yes

Show Word Count : Yes

Answers Type : Equal

Text Areas : PlainText

Possible Answers :

100

Chemistry Section A

Section Id :	864351105
Section Number :	3
Section type :	Online
Mandatory or Optional :	Mandatory
Number of Questions :	20
Number of Questions to be attempted :	20
Section Marks :	80
Mark As Answered Required? :	Yes
Sub-Section Number :	1

Sub-Section Id :

864351105

Question Shuffling Allowed :

Yes

Question Number : 31 Question Id : 8643511561 Question Type : MCQ Option Shuffling : Yes Is Question Mandatory : No

Correct Marks : 4 Wrong Marks : 1

The INCORRECT statement regarding the structure of C_{60} is :

Options :

8643514681. It contains 12 six-membered rings and 24 five-membered rings.

8643514682. The six-membered rings are fused to both six and five-membered rings.

8643514683. The five-membered rings are fused only to six-membered rings.

8643514684. Each carbon atom forms three sigma bonds.

Question Number : 31 Question Id : 8643511561 Question Type : MCQ Option Shuffling : Yes Is Question Mandatory : No

Correct Marks : 4 Wrong Marks : 1

C_{60} च्या संरचनेबद्दलचे चुकीचे विधान _____ आहे.

Options :

8643514681. त्यात 12 सहा घटकांची वलये आणि 24 पाच घटकांची वलये आहेत.

8643514682. सहा घटकांची वलये हि दोन्ही सहा आणि पाच घटकांच्या वलयांनी एकीकृत (जोडलेली) आहेत.

8643514683. पाच घटकांची वलये फक्त सहा घटकांच्या वलयांना एकीकृत (जोडलेली) आहेत.

8643514684. प्रत्येक कार्बनचा अणू तीन सिग्मा बंध तयार करतो.

Question Number : 32 Question Id : 8643511562 Question Type : MCQ Option Shuffling : Yes Is Question Mandatory : No

Correct Marks : 4 Wrong Marks : 1

The INCORRECT statements below regarding colloidal solutions is :

Options :

8643514685. A colloidal solution shows colligative properties.

8643514686. A colloidal solution shows Brownian motion of colloidal particles.

8643514687. The flocculating power of Al^{3+} is more than that of Na^+ .

8643514688. An ordinary filter paper can stop the flow of colloidal particles.

Question Number : 32 Question Id : 8643511562 Question Type : MCQ Option Shuffling : Yes Is Question Mandatory : No

Correct Marks : 4 Wrong Marks : 1

कलिली द्रावणांसंबधी खाली दिलेल्या विधानांपैकी चुकीचे विधान _____ आहे.

Options :

8643514685. कलिली द्रावण कणसंख्यावलंबी गुणधर्म दाखवते.

8643514686. कलिली द्रावणातील कण बाऊनी हालचाल दाखवतात.

8643514687. Al^{3+} ची ऊर्णनाची शक्ती Na^+ पेक्षा जास्त आहे.

8643514688. कलिली कणांचे साध्या गाळणी कागदाने प्रवाहित होणे थांबवता येते.

Question Number : 33 Question Id : 8643511563 Question Type : MCQ Option Shuffling : Yes Is Question Mandatory : No

Correct Marks : 4 Wrong Marks : 1

The characteristics of elements X, Y and Z with atomic numbers, respectively, 33, 53 and 83 are :

Options :

8643514689. X, Y and Z are metals.

8643514690. X and Z are non-metals and Y is a metalloid.

8643514691. X is a metalloid, Y is a non-metal and Z is a metal.

8643514692. X and Y are metalloids and Z is a metal.

Question Number : 33 Question Id : 8643511563 Question Type : MCQ Option Shuffling : Yes Is Question Mandatory : No

Correct Marks : 4 Wrong Marks : 1

मूलद्रव्ये X, Y आणि Z ज्यांचे अनुक्रमे अणु अंक 33, 53 आणि 83 आहेत त्यांची अभिलाक्षणिके _____ आहेत.

Options :

8643514689. X, Y आणि Z हे धातु आहेत.

8643514690. X आणि Z हे अधातु आणि Y हे धातुसदृश आहे.

8643514691. X हे धातुसदृश, Y हे अधातु आणि Z हे धातु आहे.

8643514692. X आणि Y हे धातुसदृश आणि Z हे धातु आहे.

Question Number : 34 Question Id : 8643511564 Question Type : MCQ Option Shuffling : Yes Is Question Mandatory : No

Correct Marks : 4 Wrong Marks : 1

Which of the following reduction reaction CANNOT be carried out with coke ?

Options :

8643514693. $\text{Fe}_2\text{O}_3 \rightarrow \text{Fe}$

8643514694. $\text{ZnO} \rightarrow \text{Zn}$

8643514695. $\text{Cu}_2\text{O} \rightarrow \text{Cu}$

8643514696. $\text{Al}_2\text{O}_3 \rightarrow \text{Al}$

Question Number : 34 Question Id : 8643511564 Question Type : MCQ Option Shuffling : Yes Is Question Mandatory : No

Correct Marks : 4 Wrong Marks : 1

खालीलपैकी कोणती क्षण अभिक्रिया कोक सोबत करता येत नाही?

Options :

8643514693. $\text{Fe}_2\text{O}_3 \rightarrow \text{Fe}$

8643514694. $\text{ZnO} \rightarrow \text{Zn}$

8643514695. $\text{Cu}_2\text{O} \rightarrow \text{Cu}$

8643514696. $\text{Al}_2\text{O}_3 \rightarrow \text{Al}$

Question Number : 35 Question Id : 8643511565 Question Type : MCQ Option Shuffling : Yes Is Question Mandatory : No

Correct Marks : 4 Wrong Marks : 1

The correct statements about H_2O_2 are :

- (A) used in the treatment of effluents.
- (B) used as both oxidising and reducing agents.
- (C) the two hydroxyl groups lie in the same plane.
- (D) miscible with water.

Choose the correct answer from the options given below :

Options :

8643514697. (A), (B) and (D) only

8643514698. (B), (C) and (D) only

8643514699. (A), (C) and (D) only

8643514700. (A), (B), (C) and (D)

Question Number : 35 Question Id : 8643511565 Question Type : MCQ Option Shuffling : Yes Is Question Mandatory : No

Correct Marks : 4 Wrong Marks : 1

H_2O_2 संबंधी बरोबर विधाने _____ आहेत.

- (A) निःसृतद्राव प्रक्रियेसाठी वापरतात.
(B) ऑक्सिडीकारक आणि क्षपणकारक ह्या दोन्हीसाठी उपयोग होतो.
(C) दोन्ही हायड्रॉक्सिल गट एकाच प्रतलात असतात.
(D) पाण्याबरोबर मिश्रणीय आहे.

खालील पर्यायांमधून बरोबर उत्तर निवडा.

Options :

8643514697. (A), (B) आणि (D) फक्त

8643514698. (B), (C) आणि (D) फक्त

8643514699. (A), (C) आणि (D) फक्त

8643514700. (A), (B), (C) आणि (D)

Question Number : 36 Question Id : 8643511566 Question Type : MCQ Option Shuffling : Yes Is Question Mandatory : No

Correct Marks : 4 Wrong Marks : 1

Identify the elements X and Y using the ionisation energy values given below :

Ionization energy (kJ/mol)

	1 st	2 nd
X	495	4563
Y	731	1450

Options :

8643514701. X = Na ; Y = Mg

8643514702. X = Mg ; Y = Na

8643514703. X = F ; Y = Mg

8643514704. X = Mg ; Y = F

Question Number : 36 Question Id : 8643511566 Question Type : MCQ Option Shuffling : Yes Is Question Mandatory : No

Correct Marks : 4 Wrong Marks : 1

खाली दिलेल्या आयनन ऊर्जेच्या मूल्यांवरून मूलद्रव्ये X आणि Y ठरवा :

	आयनन ऊर्जा	(kJ/mol)
	प्रथम (1 st)	दुसरी (2 nd)
X	495	4563
Y	731	1450

Options :

8643514701. X = Na ; Y = Mg

8643514702. X = Mg ; Y = Na

8643514703. X = F ; Y = Mg

8643514704. X = Mg ; Y = F

Question Number : 37 Question Id : 8643511567 Question Type : MCQ Option Shuffling : Yes Is Question Mandatory : No

Correct Marks : 4 Wrong Marks : 1

The exact volumes of 1 M NaOH solution required to neutralise 50 mL of 1 M H_3PO_3 solution and 100 mL of 2 M H_3PO_2 solution, respectively, are :

Options :

8643514705. 50 mL and 50 mL

8643514706. 100 mL and 50 mL

8643514707. 100 mL and 200 mL

8643514708. 100 mL and 100 mL

Question Number : 37 Question Id : 8643511567 Question Type : MCQ Option Shuffling : Yes Is Question Mandatory : No

Correct Marks : 4 Wrong Marks : 1

50 mL 1 M H_3PO_3 आणि 100 mL 2 M H_3PO_2 द्रावणांच्या उदासीनीकरणात लागणारे 1 M NaOH चे बरोबर आकारमान अनुक्रमे _____ आहे.

Options :

8643514705. 50 mL आणि 50 mL
8643514706. 100 mL आणि 50 mL
8643514707. 100 mL आणि 200 mL
8643514708. 100 mL आणि 100 mL

Question Number : 38 Question Id : 8643511568 Question Type : MCQ Option Shuffling : Yes Is Question Mandatory : No

Correct Marks : 4 Wrong Marks : 1

Arrange the following metal complex/compounds in the increasing order of spin only magnetic moment. Presume all the three, high spin system.

(Atomic numbers Ce = 58, Gd = 64 and Eu = 63.)

(a) $(\text{NH}_4)_2[\text{Ce}(\text{NO}_3)_6]$ (b) $\text{Gd}(\text{NO}_3)_3$ and (c) $\text{Eu}(\text{NO}_3)_3$

Answer is :

Options :

8643514709. (a) < (b) < (c)
8643514710. (a) < (c) < (b)
8643514711. (b) < (a) < (c)
8643514712. (c) < (a) < (b)

Question Number : 38 Question Id : 8643511568 Question Type : MCQ Option Shuffling : Yes Is Question Mandatory : No

Correct Marks : 4 Wrong Marks : 1

खालील धातु जटिल/संयुगातील स्पीन फक्त चुंबकीय आघूर्णांचा चढता क्रम लावा, सर्व तीनही उच्च अभ्राम सिस्टिम आहेत असे समजा.

(अणुअंक Ce = 58, Gd = 64 आणि Eu = 63)

(a) $(\text{NH}_4)_2[\text{Ce}(\text{NO}_3)_6]$ (b) $\text{Gd}(\text{NO}_3)_3$ आणि (c) $\text{Eu}(\text{NO}_3)_3$

Options :

8643514709. (a) < (b) < (c)

8643514710. (a) < (c) < (b)

8643514711. (b) < (a) < (c)

8643514712. (c) < (a) < (b)

Question Number : 39 Question Id : 8643511569 Question Type : MCQ Option Shuffling : Yes Is Question Mandatory : No

Correct Marks : 4 Wrong Marks : 1

Fex_2 and Fey_3 are known when x and y are :

Options :

8643514713. $x = \text{F, Cl, Br, I}$ and $y = \text{F, Cl, Br, I}$

8643514714. $x = \text{F, Cl, Br, I}$ and $y = \text{F, Cl, Br}$

8643514715. $x = \text{F, Cl, Br}$ and $y = \text{F, Cl, Br, I}$

8643514716. $x = \text{Cl, Br, I}$ and $y = \text{F, Cl, Br, I}$

Question Number : 39 Question Id : 8643511569 Question Type : MCQ Option Shuffling : Yes Is Question Mandatory : No

Correct Marks : 4 Wrong Marks : 1

माहित असलेल्या Fex_2 आणि Fey_3 मधील x आणि y _____ आहेत.

Options :

8643514713. $x = \text{F, Cl, Br, I}$ आणि $y = \text{F, Cl, Br, I}$

8643514714. $x = F, Cl, Br, I$ आणि $y = F, Cl, Br$

8643514715. $x = F, Cl, Br$ आणि $y = F, Cl, Br, I$

8643514716. $x = Cl, Br, I$ आणि $y = F, Cl, Br, I$

Question Number : 40 Question Id : 8643511570 Question Type : MCQ Option Shuffling : Yes Is Question Mandatory : No

Correct Marks : 4 Wrong Marks : 1

The green house gas/ es is (are) :

- (A) Carbon dioxide
- (B) Oxygen
- (C) Water vapour
- (D) Methane

Choose the most appropriate answer from the options given below :

Options :

8643514717. (A) only

8643514718. (A) and (C) only

8643514719. (A), (C) and (D) only

8643514720. (A) and (B) only

Question Number : 40 Question Id : 8643511570 Question Type : MCQ Option Shuffling : Yes Is Question Mandatory : No

Correct Marks : 4 Wrong Marks : 1

ग्रीनहाऊस वायू _____ आहे/आहेत.

- (A) कार्बन डायऑक्साइड
- (B) ऑक्सिजन
- (C) पाण्याची वाफ
- (D) मिथेन

खालील पर्यायांमधून योग्य उत्तर निवडा.

Options :

8643514717. (A) फक्त

8643514718. (A) आणि (C) फक्त

8643514719. (A), (C) आणि (D) फक्त

8643514720. (A) आणि (B) फक्त

Question Number : 41 Question Id : 8643511571 Question Type : MCQ Option Shuffling : Yes Is Question Mandatory : No

Correct Marks : 4 Wrong Marks : 1

Match List-I with List-II :

List-I	List-II
Test/Reagents/Observation(s)	Species detected
(a) Lassaigne's Test	(i) Carbon
(b) Cu(II) oxide	(ii) Sulphur
(c) Silver nitrate	(iii) N, S, P, and halogen
(d) The sodium fusion extract gives black precipitate with acetic acid and lead acetate	(iv) Halogen Specifically

The correct match is :

Options :

8643514721. (a)-(i), (b)-(ii), (c)-(iv), (d)-(iii)

8643514722. (a)-(iii), (b)-(i), (c)-(iv), (d)-(ii)

8643514723. (a)-(iii), (b)-(i), (c)-(ii), (d)-(iv)

8643514724. (a)-(i), (b)-(iv), (c)-(iii), (d)-(ii)

Question Number : 41 Question Id : 8643511571 Question Type : MCQ Option Shuffling : Yes Is Question Mandatory : No

Correct Marks : 4 Wrong Marks : 1

यादी-I यादी-II शी जुळवा :

यादी-I	यादी-II
चाचणी/अभिक्रियाकारक/दर्शवणे	शोधलेली जाती
(a) लसायनाची चाचणी	(i) कार्बन
(b) Cu(II) ऑक्साइड	(ii) सल्फर
(c) सिल्व्हर नायट्रेट	(iii) N, S, P, आणि हॅलोजन्स
(d) अॅसेटिक आम्ल व लेड अॅसिटेट सोडिअम फ्युजन अर्कासोबत काळ अवक्षेप देते	(iv) हॅलोजनसाठी फक्त

योग्य जोडी आहे.

Options :

8643514721. (a)-(i), (b)-(ii), (c)-(iv), (d)-(iii)

8643514722. (a)-(iii), (b)-(i), (c)-(iv), (d)-(ii)

8643514723. (a)-(iii), (b)-(i), (c)-(ii), (d)-(iv)

8643514724. (a)-(i), (b)-(iv), (c)-(iii), (d)-(ii)

Question Number : 42 Question Id : 8643511572 Question Type : MCQ Option Shuffling : Yes Is Question Mandatory : No

Correct Marks : 4 Wrong Marks : 1

Statement I : Sodium hydride can be used as an oxidising agent.

Statement II : The lone pair of electrons on nitrogen in pyridine makes it basic.

Choose the **CORRECT** answer from the options given below :

Options :

8643514725. Both statement I and statement II are true

8643514726. Both statement I and statement II are false

8643514727. Statement I is true but statement II is false

8643514728. Statement I is false but statement II is true

Question Number : 42 Question Id : 8643511572 Question Type : MCQ Option Shuffling : Yes Is Question Mandatory : No

Correct Marks : 4 Wrong Marks : 1

विधान I : सोडीअम हायड्राइड ऑक्सिडीकारक म्हणून वापरू शकतात.

विधान II : पायरिडिनच्या नायट्रोजनवरील विविक्त इलेक्ट्रॉन युग्मांमुळे ते आम्लारि धर्मी आहे.

खाली दिलेल्या पर्यायांमधून बरोबर उत्तर निवडा.

Options :

8643514725. दोन्ही विधाने विधान I आणि विधान II खरी आहेत.

8643514726. दोन्ही विधाने विधान I आणि विधान II खोटी आहेत.

8643514727. विधान I खरे आणि विधान II खोटे आहे.

8643514728. विधान I खोटे आणि विधान II खरे आहे.

Question Number : 43 Question Id : 8643511573 Question Type : MCQ Option Shuffling : Yes Is Question Mandatory : No

Correct Marks : 4 Wrong Marks : 1

An unsaturated hydrocarbon X on ozonolysis gives A. Compound A when warmed with ammonical silver nitrate forms a bright silver mirror along the sides of the test tube. The unsaturated hydrocarbon X is :

Options :

8643514729. $\text{CH}_3 - \text{C} \equiv \text{C} - \text{CH}_3$

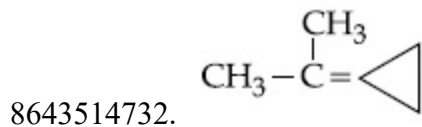
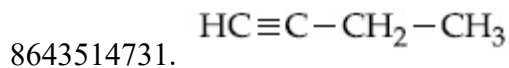
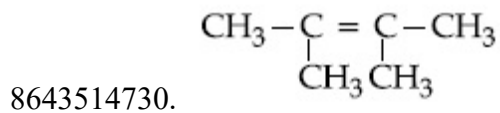

Question Number : 43 Question Id : 8643511573 Question Type : MCQ Option Shuffling : Yes Is Question Mandatory : No

Correct Marks : 4 Wrong Marks : 1

एका असंतृप्त हायड्रोकार्बन X चे ओझोनोलाइसिस केले असता A मिळते संयुग A जेव्हा अमोनियाकल सिल्व्हर नायट्रेटबरोबर तापवले तर चकचकित चांदीचा आरसा नळिच्या आतल्या बाजुस तयार झाला. ते असंतृप्त हायड्रोकार्बन X _____ आहे.

Options :

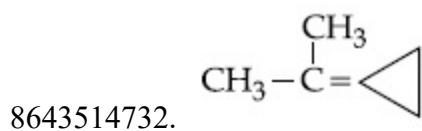
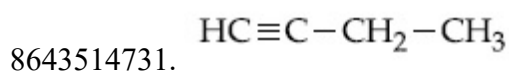
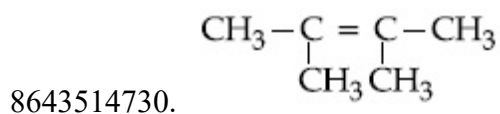
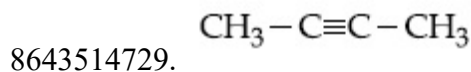

Question Number : 44 Question Id : 8643511574 Question Type : MCQ Option Shuffling : Yes Is Question Mandatory : No

Correct Marks : 4 Wrong Marks : 1

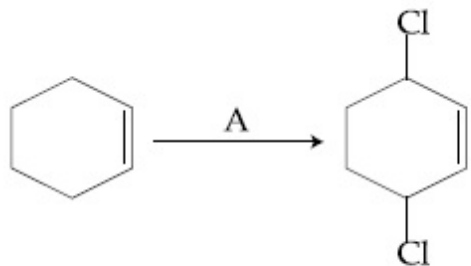

Identify the reagent(s) 'A' and condition(s) for the reaction

Options :

8643514733. A = Cl_2 ; dark, Anhydrous AlCl_3

8643514734. A = HCl , ZnCl_2

8643514735. A = Cl_2 ; UV light

8643514736. A = HCl ; Anhydrous AlCl_3

Question Number : 44 Question Id : 8643511574 Question Type : MCQ Option Shuffling : Yes Is Question Mandatory : No

Correct Marks : 4 Wrong Marks : 1

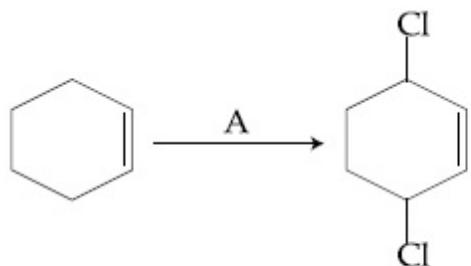

अभिक्रियेसाठी अभिक्रियाकारक 'A' आणि स्थिती ओळखा.

Options :

8643514733. A = Cl_2 ; काळोख, निर्जल AlCl_3

8643514734. A = HCl , ZnCl_2

8643514735. A = Cl_2 ; UV प्रकाश

8643514736. A = HCl ; निर्जल AlCl_3

Question Number : 45 Question Id : 8643511575 Question Type : MCQ Option Shuffling : Yes Is

Question Mandatory : No

Correct Marks : 4 Wrong Marks : 1

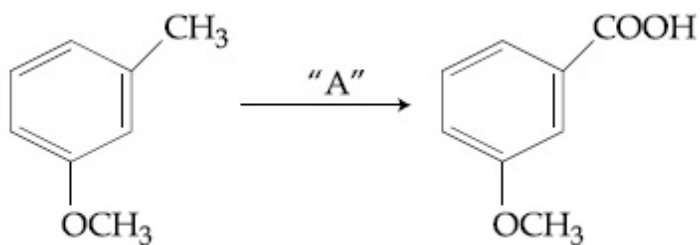

In the above reaction, the reagent "A" is :

Options :

8643514737. LiAlH_4

8643514738. Alkaline KMnO_4 , H^+

8643514739. HCl , $\text{Zn} - \text{Hg}$

8643514740. NaBH_4 , H_3O^+

Question Number : 45 Question Id : 8643511575 Question Type : MCQ Option Shuffling : Yes Is

Question Mandatory : No

Correct Marks : 4 Wrong Marks : 1

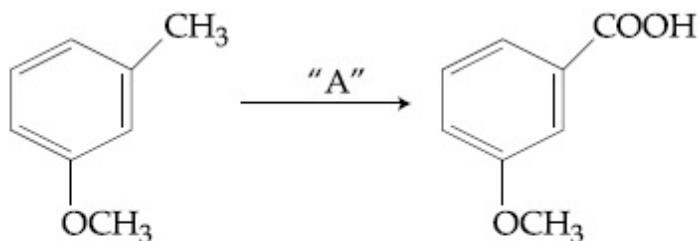

वरील अभिक्रियेतील, "A" अभिक्रियाकारक आहे :

Options :

8643514737. LiAlH_4

8643514738. आम्लारीधर्मी KMnO_4 , H^+

8643514739. HCl , $\text{Zn} - \text{Hg}$

8643514740. NaBH_4 , H_3O^+

Question Number : 46 Question Id : 8643511576 Question Type : MCQ Option Shuffling : Yes Is Question Mandatory : No Correct Marks : 4 Wrong Marks : 1

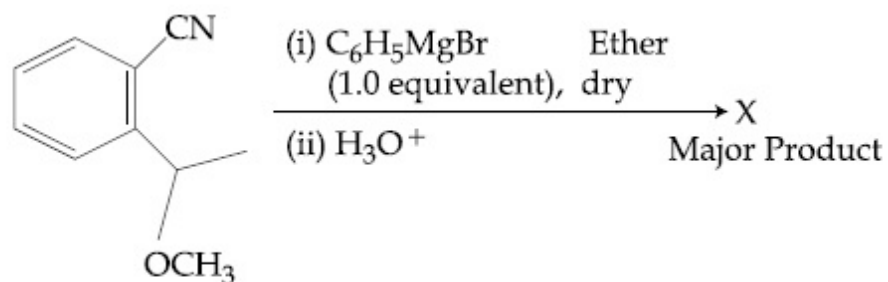

The structure of X is :

Options :

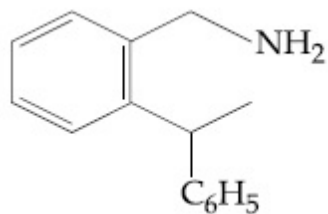
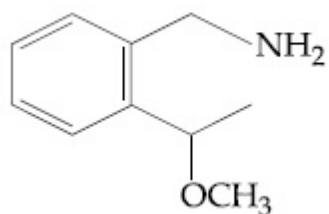
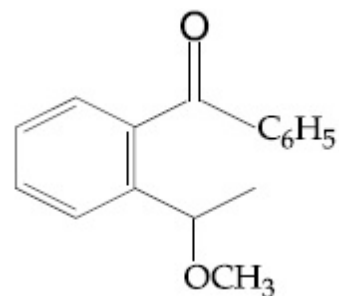

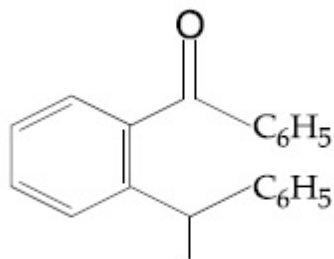

8643514744.

Question Number : 46 Question Id : 8643511576 Question Type : MCQ Option Shuffling : Yes Is Question Mandatory : No

Correct Marks : 4 Wrong Marks : 1

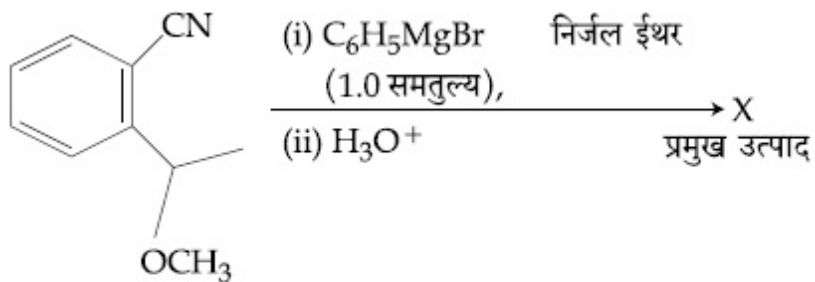

X ची संरचना _____ आहे.

Options :

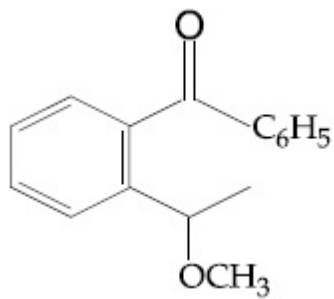

8643514741.

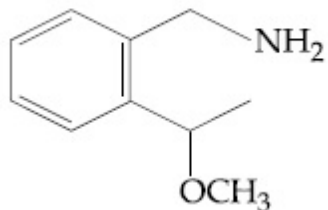

8643514742.

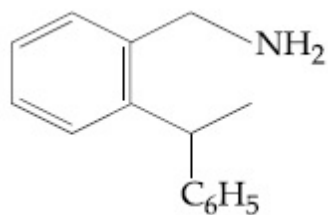

8643514743.

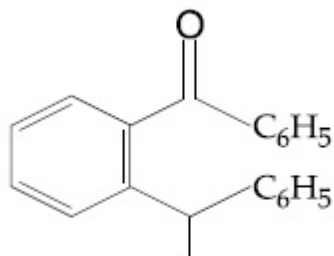

8643514744.

Question Number : 47 Question Id : 8643511577 Question Type : MCQ Option Shuffling : Yes Is Question Mandatory : No

Correct Marks : 4 Wrong Marks : 1

Which of the following is least basic ?

Options :

8643514745. $(\text{CH}_3\text{CO})_2\ddot{\text{N}}\text{H}$

8643514746. $(\text{C}_2\text{H}_5)_2\ddot{\text{N}}\text{H}$

8643514747. $(\text{CH}_3\text{CO})\ddot{\text{N}}\text{HC}_2\text{H}_5$

8643514748. $(\text{C}_2\text{H}_5)_3\ddot{\text{N}}$

Question Number : 47 Question Id : 8643511577 Question Type : MCQ Option Shuffling : Yes Is Question Mandatory : No

Correct Marks : 4 Wrong Marks : 1

खालीलपैकी सगळ्यात कमी आम्लारिधर्मी कोण आहे?

Options :

8643514745. $(\text{CH}_3\text{CO})_2\ddot{\text{N}}\text{H}$

8643514746. $(\text{C}_2\text{H}_5)_2\ddot{\text{N}}\text{H}$

8643514747. $(\text{CH}_3\text{CO})\ddot{\text{N}}\text{HC}_2\text{H}_5$

8643514748. $(\text{C}_2\text{H}_5)_3\ddot{\text{N}}$

Question Number : 48 Question Id : 8643511578 Question Type : MCQ Option Shuffling : Yes Is Question Mandatory : No

Correct Marks : 4 Wrong Marks : 1

Ammonolysis of Alkyl halides followed by the treatment with NaOH solution can be used to prepare primary, secondary and tertiary amines. The purpose of NaOH in the reaction is :

Options :

8643514749. to remove basic impurities
8643514750. to activate NH_3 used in the reaction
8643514751. to increase the reactivity of alkyl halide
8643514752. to remove acidic impurities

Question Number : 48 Question Id : 8643511578 Question Type : MCQ Option Shuffling : Yes Is Question Mandatory : No

Correct Marks : 4 Wrong Marks : 1

अल्किल हलाइडसच्या अमोनोलाइसिसनंतर NaOH च्या द्रावणाबरोबर प्रक्रिया केली असता प्राथमिक, दुय्यम आणि तृतीयक अमाइन्स तयार करता येतात. NaOH च्या वापराचा हेतू _____ आहे.

Options :

8643514749. आम्लारिधर्मी अशुद्धता काढण्यासाठी.
8643514750. अभिक्रियेतील वापरण्यात आलेल्या NH_3 ला सक्रियित करण्यासाठी.
8643514751. अल्किल हलाइडला जास्त सक्रियित करण्यासाठी.
8643514752. आम्लधर्मी अशुद्धता काढण्यासाठी.

Question Number : 49 Question Id : 8643511579 Question Type : MCQ Option Shuffling : Yes Is Question Mandatory : No

Correct Marks : 4 Wrong Marks : 1

Which of the following polymer is used in the manufacture of wood laminates ?

Options :

8643514753. Melamine formaldehyde resin

8643514754. Urea formaldehyde resin

8643514755. *cis*-poly isoprene

8643514756. Phenol and formaldehyde resin

Question Number : 49 Question Id : 8643511579 Question Type : MCQ Option Shuffling : Yes Is Question Mandatory : No

Correct Marks : 4 Wrong Marks : 1

लाकडी स्तरितांच्या निर्मितीमध्ये खालीलपैकी कोणते बहुवारिक वापरतात?

Options :

8643514753. मेलॅमाइन फॉरमाल्डीहाइड रेझिन

8643514754. युरिआ फॉरमाल्डीहाइड रेझिन

8643514755. *cis*-पॉली आयसोप्रीन

8643514756. फिनॉल आणि फॉरमाल्डीहाइड रेझिन

Question Number : 50 Question Id : 8643511580 Question Type : MCQ Option Shuffling : Yes Is Question Mandatory : No

Correct Marks : 4 Wrong Marks : 1

The secondary structure of protein is stabilised by :

Options :

8643514757. van der Waals forces

8643514758. Peptide bond

8643514759. Hydrogen bonding

8643514760. glycosidic bond

Question Number : 50 Question Id : 8643511580 Question Type : MCQ Option Shuffling : Yes Is Question Mandatory : No

Correct Marks : 4 Wrong Marks : 1

प्रथिनांच्या दुय्यम संरूपणाची स्थिरता _____ आहे.

Options :

8643514757. वॅन दे वॉल्झ बले

8643514758. पेप्टाइड बंध

8643514759. हायड्रोजन बंध

8643514760. ग्लायकोसायडी बंध

Chemistry Section B

Section Id :	864351106
Section Number :	4
Section type :	Online
Mandatory or Optional :	Mandatory
Number of Questions :	10
Number of Questions to be attempted :	5
Section Marks :	20
Mark As Answered Required? :	Yes
Sub-Section Number :	1
Sub-Section Id :	864351106
Question Shuffling Allowed :	Yes

Question Number : 51 Question Id : 8643511581 Question Type : SA

Correct Marks : 4 Wrong Marks : 0

When 35 mL of 0.15 M lead nitrate solution is mixed with 20 mL of 0.12 M chromic sulphate solution, _____ $\times 10^{-5}$ moles of lead sulphate precipitate out. (Round off to the Nearest Integer).

Response Type : Numeric

Evaluation Required For SA : Yes

Show Word Count : Yes

Answers Type : Equal

Text Areas : PlainText

Possible Answers :

100

Question Number : 51 Question Id : 8643511581 Question Type : SA

Correct Marks : 4 Wrong Marks : 0

जेव्हा 20 mL 0.12 M क्रोमिक सल्फेट द्रावणाला 35 mL 0.15 M लेड नायट्रेट द्रावणात मिसळले तेव्हा _____ $\times 10^{-5}$ मोल्स लेड सल्फेटचे अवक्षेपण झाले. (जवळच्या पूर्णांकात)

Response Type : Numeric

Evaluation Required For SA : Yes

Show Word Count : Yes

Answers Type : Equal

Text Areas : PlainText

Possible Answers :

100

Question Number : 52 **Question Id :** 8643511582 **Question Type :** SA

Correct Marks : 4 **Wrong Marks :** 0

Ga (atomic mass 70 u) crystallizes in a hexagonal close packed structure. The total number of voids in 0.581 g of Ga is _____ $\times 10^{21}$. (Round off to the Nearest Integer).

[Given : $N_A = 6.023 \times 10^{23}$]

Response Type : Numeric

Evaluation Required For SA : Yes

Show Word Count : Yes

Answers Type : Equal

Text Areas : PlainText

Possible Answers :

100

Question Number : 52 **Question Id :** 8643511582 **Question Type :** SA

Correct Marks : 4 **Wrong Marks :** 0

Ga (अणु वस्तुमान 70 u) चे षट्कोनी क्लोज पॅकड संरचनेत स्फटिकीकरण होते. 0.581 g Ga मधील पोकळ्यांची एकूण संख्या _____ $\times 10^{21}$ आहे. (जवळच्या पूर्णांकात)

[दिलेले आहे : $N_A = 6.023 \times 10^{23}$]

Response Type : Numeric

Evaluation Required For SA : Yes

Show Word Count : Yes

Answers Type : Equal

Text Areas : PlainText

Possible Answers :

100

Question Number : 53 **Question Id :** 8643511583 **Question Type :** SA

Correct Marks : 4 **Wrong Marks :** 0

The number of orbitals with $n=5$, $m_l = +2$ is _____. (Round off to the Nearest Integer).

Response Type : Numeric

Evaluation Required For SA : Yes

Show Word Count : Yes

Answers Type : Equal

Text Areas : PlainText

Possible Answers :

100

Question Number : 53 Question Id : 8643511583 Question Type : SA

Correct Marks : 4 Wrong Marks : 0

$n=5$, $m_l = +2$ मधील कक्षिकांची संख्या _____ आहे. (पूर्णाकात उत्तर)

Response Type : Numeric

Evaluation Required For SA : Yes

Show Word Count : Yes

Answers Type : Equal

Text Areas : PlainText

Possible Answers :

100

Question Number : 54 Question Id : 8643511584 Question Type : SA

Correct Marks : 4 Wrong Marks : 0

At 25°C , 50 g of iron reacts with HCl to form FeCl_2 . The evolved hydrogen gas expands against a constant pressure of 1 bar. The work done by the gas during this expansion is _____ J.

(Round off to the Nearest Integer).

[Given : $R = 8.314 \text{ J mol}^{-1} \text{ K}^{-1}$. Assume, hydrogen is an ideal gas]

[Atomic mass of Fe is 55.85 u]

Response Type : Numeric

Evaluation Required For SA : Yes

Show Word Count : Yes

Answers Type : Equal

Text Areas : PlainText

Possible Answers :

100

Question Number : 54 Question Id : 8643511584 Question Type : SA

Correct Marks : 4 Wrong Marks : 0

25°C ला 50 g लोखंडाची HCl बरोबर अभिक्रिया केल्यास FeCl_2 तयार होते. निर्माण होणाऱ्या हायड्रोजन वायूचे 1 bar दाबाविरुद्ध प्रसरण होते. ह्या प्रसरणातील वायूने केलेले कार्य _____ J आहे. (जवळच्या पूर्णांकात)
(दिलेले आहे : $R = 8.314 \text{ J mol}^{-1} \text{ K}^{-1}$. हायड्रोजन एक आदर्श वायू आहे असे समजा)

(Fe अणु वस्तुमान = 55.85 u)

Response Type : Numeric

Evaluation Required For SA : Yes

Show Word Count : Yes

Answers Type : Equal

Text Areas : PlainText

Possible Answers :

100

Question Number : 55 **Question Id :** 8643511585 **Question Type :** SA

Correct Marks : 4 **Wrong Marks :** 0

At 363 K, the vapour pressure of A is 21 kPa and that of B is 18 kPa. One mole of A and 2 moles of B are mixed. Assuming that this solution is ideal, the vapour pressure of the mixture is _____ kPa. (Round off to the Nearest Integer).

Response Type : Numeric

Evaluation Required For SA : Yes

Show Word Count : Yes

Answers Type : Equal

Text Areas : PlainText

Possible Answers :

100

Question Number : 55 **Question Id :** 8643511585 **Question Type :** SA

Correct Marks : 4 **Wrong Marks :** 0

363 K तापमानाला A चा बाष्पदाब 21 kPa व B चा 18 kPa आहे. A चा एक मोल आणि B चे दोन मोल्स मिसळले. हे द्रावण आदर्श आहे असे समजा, तर मिश्रणाचा बाष्पदाब _____ kPa आहे. (जवळच्या पूर्णांकात)

Response Type : Numeric

Evaluation Required For SA : Yes

Show Word Count : Yes

Answers Type : Equal

Text Areas : PlainText

Possible Answers :

100

Question Number : 56 Question Id : 8643511586 Question Type : SA

Correct Marks : 4 Wrong Marks : 0

Sulphurous acid (H_2SO_3) has $K_{a1} = 1.7 \times 10^{-2}$ and $K_{a2} = 6.4 \times 10^{-8}$. The pH of 0.588 M H_2SO_3 is _____. (Round off to the Nearest Integer).

Response Type : Numeric

Evaluation Required For SA : Yes

Show Word Count : Yes

Answers Type : Equal

Text Areas : PlainText

Possible Answers :

100

Question Number : 56 Question Id : 8643511586 Question Type : SA

Correct Marks : 4 Wrong Marks : 0

सल्फ्युरस आम्लासाठी (H_2SO_3) $K_{a1} = 1.7 \times 10^{-2}$ आणि $K_{a2} = 6.4 \times 10^{-8}$ आहेत. 0.588 M H_2SO_3 साठी pH _____ आहे. (जवळच्या पूर्णांकात)

Response Type : Numeric

Evaluation Required For SA : Yes

Show Word Count : Yes

Answers Type : Equal

Text Areas : PlainText

Possible Answers :

100

Question Number : 57 Question Id : 8643511587 Question Type : SA

Correct Marks : 4 Wrong Marks : 0

A $5.0 \text{ m mol dm}^{-3}$ aqueous solution of KCl has a conductance of 0.55 mS when measured in a cell of cell constant 1.3 cm^{-1} . The molar conductivity of this solution is _____ $\text{mSm}^2 \text{ mol}^{-1}$. (Round off to the Nearest Integer).

Response Type : Numeric

Evaluation Required For SA : Yes

Show Word Count : Yes

Answers Type : Equal

Text Areas : PlainText

Possible Answers :

100

Question Number : 57 Question Id : 8643511587 Question Type : SA

Correct Marks : 4 Wrong Marks : 0

1.3 cm⁻¹ घट स्थिरांक असलेल्या घटात 5.0 m mol dm⁻³ KCl च्या जलीय द्रावणाचे प्रवहन 0.55 mS आहे. ह्या द्रावणाची मोलर वाहकता _____ mSm² mol⁻¹ आहे. (जवळच्या पूर्णांकात)

Response Type : Numeric

Evaluation Required For SA : Yes

Show Word Count : Yes

Answers Type : Equal

Text Areas : PlainText

Possible Answers :

100

Question Number : 58 Question Id : 8643511588 Question Type : SA

Correct Marks : 4 Wrong Marks : 0

A and B decompose via first order kinetics with half-lives 54.0 min and 18.0 min respectively. Starting from an equimolar non reactive mixture of A and B, the time taken for the concentration of A to become 16 times that of B is _____ min. (Round off to the Nearest Integer).

Response Type : Numeric

Evaluation Required For SA : Yes

Show Word Count : Yes

Answers Type : Equal

Text Areas : PlainText

Possible Answers :

100

Question Number : 58 Question Id : 8643511588 Question Type : SA

Correct Marks : 4 Wrong Marks : 0

प्रथम कोटी गतिजानुसार A आणि B चे विघटन होते त्यासाठी अनुक्रमे 54.0 min आणि 18.0 min अर्धायुकाळ आहेत. A आणि B चे अक्रियाशील सममोलर मिश्रण सुरवातीला घेतले असता A ची संहती B च्या 16 पट होण्यासाठी लागणारा वेळ _____ min असेल. (जवळच्या पूर्णांकात)

Response Type : Numeric

Evaluation Required For SA : Yes

Show Word Count : Yes

Answers Type : Equal

Text Areas : PlainText

Possible Answers :

100

Question Number : 59 Question Id : 8643511589 Question Type : SA

Correct Marks : 4 Wrong Marks : 0

$[\text{Ti}(\text{H}_2\text{O})_6]^{3+}$ absorbs light of wavelength 498 nm during a d – d transition. The octahedral splitting energy for the above complex is _____ $\times 10^{-19}$ J. (Round off to the Nearest Integer). $h = 6.626 \times 10^{-34}$ Js; $c = 3 \times 10^8$ ms⁻¹

Response Type : Numeric

Evaluation Required For SA : Yes

Show Word Count : Yes

Answers Type : Equal

Text Areas : PlainText

Possible Answers :

100

Question Number : 59 Question Id : 8643511589 Question Type : SA

Correct Marks : 4 Wrong Marks : 0

d – d च्या संक्रमणासाठी $[\text{Ti}(\text{H}_2\text{O})_6]^{3+}$ 498 nm तरंगलांबीचा प्रकाश शोषून घेतो. वरील जटिलाची अष्टपृष्ठी विभाजनाची ऊर्जा _____ $\times 10^{-19}$ J आहे. (जवळच्या पूर्णांकात)

$h = 6.626 \times 10^{-34}$ Js; $c = 3 \times 10^8$ ms⁻¹

Response Type : Numeric

Evaluation Required For SA : Yes

Show Word Count : Yes

Answers Type : Equal

Text Areas : PlainText

Possible Answers :

100

Question Number : 60 Question Id : 8643511590 Question Type : SA

Correct Marks : 4 Wrong Marks : 0

In Duma's method of estimation of nitrogen, 0.1840 g of an organic compound gave 30 mL of nitrogen collected at 287 K and 758 mm of Hg pressure. The percentage composition of nitrogen in the compound is _____. (Round off to the Nearest Integer).

[Given : Aqueous tension at 287 K = 14 mm of Hg]

Response Type : Numeric

Evaluation Required For SA : Yes

Show Word Count : Yes

Answers Type : Equal

Text Areas : PlainText

Possible Answers :

100

Question Number : 60 Question Id : 8643511590 Question Type : SA

Correct Marks : 4 Wrong Marks : 0

नायट्रोजनच्या निर्धारणाच्या ड्युमाच्या पद्धतीत, 0.1840 g एका कार्बनी संयुगाने 30 mL नायट्रोजन 287 K आणि 758 mm Hg च्या दाबाला जमा केला. त्या संयुगातील नायट्रोजनची संघटनातील टक्केवारी _____ आहे. (जवळच्या पूर्णांकात)

(दिलेले : पाण्याचा दाब 14 mm Hg 287 K तापमानाला)

Response Type : Numeric

Evaluation Required For SA : Yes

Show Word Count : Yes

Answers Type : Equal

Text Areas : PlainText

Possible Answers :

100

Mathematics Section A

Section Id :	864351107
Section Number :	5
Section type :	Online
Mandatory or Optional :	Mandatory
Number of Questions :	20
Number of Questions to be attempted :	20
Section Marks :	80
Mark As Answered Required? :	Yes
Sub-Section Number :	1
Sub-Section Id :	864351107
Question Shuffling Allowed :	Yes

Question Number : 61 Question Id : 8643511591 Question Type : MCQ Option Shuffling : Yes Is

Question Mandatory : No

Correct Marks : 4 Wrong Marks : 1

If the foot of the perpendicular from point (4, 3, 8) on the line $L_1 : \frac{x - a}{l} = \frac{y - 2}{3} = \frac{z - b}{4}$,

$l \neq 0$ is (3, 5, 7), then the shortest distance between the line L_1 and line

$L_2 : \frac{x - 2}{3} = \frac{y - 4}{4} = \frac{z - 5}{5}$ is equal to :

Options :

8643514771. $\frac{1}{\sqrt{6}}$

8643514772. $\frac{1}{2}$

8643514773. $\frac{1}{\sqrt{3}}$

8643514774. $\sqrt{\frac{2}{3}}$

Question Number : 61 Question Id : 8643511591 Question Type : MCQ Option Shuffling : Yes Is Question Mandatory : No

Correct Marks : 4 Wrong Marks : 1

जर $L_1 : \frac{x-a}{l} = \frac{y-2}{3} = \frac{z-b}{4}, l \neq 0$ या रेषेवरील $(4, 3, 8)$ या बिंदू पासून काढलेला लंबाचा पाया

(foot of the perpendicular) $(3, 5, 7)$ आहे, तर रेषा L_1 आणि रेषा

$L_2 : \frac{x-2}{3} = \frac{y-4}{4} = \frac{z-5}{5}$ यांच्या मधील लहानात लहान अंतर (shortest distance) बरोबर

_____ आहे.

Options :

8643514771. $\frac{1}{\sqrt{6}}$

8643514772. $\frac{1}{2}$

8643514773. $\frac{1}{\sqrt{3}}$

8643514774. $\sqrt{\frac{2}{3}}$

Question Number : 62 Question Id : 8643511592 Question Type : MCQ Option Shuffling : Yes Is Question Mandatory : No

Correct Marks : 4 Wrong Marks : 1

Let the lengths of intercepts on x -axis and y -axis made by the circle $x^2 + y^2 + ax + 2ay + c = 0$, ($a < 0$) be $2\sqrt{2}$ and $2\sqrt{5}$, respectively. Then the shortest distance from origin to a tangent to this circle which is perpendicular to the line $x + 2y = 0$, is equal to :

Options :

8643514775. $\sqrt{10}$

8643514776. $\sqrt{11}$

8643514777. $\sqrt{7}$

8643514778. $\sqrt{6}$

Question Number : 62 Question Id : 8643511592 Question Type : MCQ Option Shuffling : Yes Is Question Mandatory : No

Correct Marks : 4 Wrong Marks : 1

समजा $x^2 + y^2 + ax + 2ay + c = 0$, ($a < 0$) या वर्तुळाने x -अक्ष व y -अक्ष यांच्यावर तयार केलेल्या आंतरखंडां (intercepts) ची लांबी अनुक्रमे $2\sqrt{2}$ आणि $2\sqrt{5}$ आहे. तर आरंभबिंदूपासून वर्तुळाच्या स्पर्शिकेचे सर्वात कमी अंतर, ही स्पर्शिका $x + 2y = 0$ या रेषेला लंब आहे, बरोबर _____ आहे.

Options :

8643514775. $\sqrt{10}$

8643514776. $\sqrt{11}$

8643514777. $\sqrt{7}$

8643514778. $\sqrt{6}$

Question Number : 63 Question Id : 8643511593 Question Type : MCQ Option Shuffling : Yes Is Question Mandatory : No

Correct Marks : 4 Wrong Marks : 1

Let $\vec{a} = \hat{i} + 2\hat{j} - 3\hat{k}$ and $\vec{b} = 2\hat{i} - 3\hat{j} + 5\hat{k}$. If $\vec{r} \times \vec{a} = \vec{b} \times \vec{r}$, $\vec{r} \cdot (\alpha\hat{i} + 2\hat{j} + \hat{k}) = 3$

and $\vec{r} \cdot (2\hat{i} + 5\hat{j} - \alpha\hat{k}) = -1$, $\alpha \in \mathbb{R}$, then the value of $\alpha + |\vec{r}|^2$ is equal to :

Options :

8643514779. 9

8643514780. 11

8643514781. 13

8643514782. 15

Question Number : 63 Question Id : 8643511593 Question Type : MCQ Option Shuffling : Yes Is Question Mandatory : No

Correct Marks : 4 Wrong Marks : 1

समजा $\vec{a} = \hat{i} + 2\hat{j} - 3\hat{k}$ आणि $\vec{b} = 2\hat{i} - 3\hat{j} + 5\hat{k}$. जर $\vec{r} \times \vec{a} = \vec{b} \times \vec{r}$,

$\vec{r} \cdot (\alpha\hat{i} + 2\hat{j} + \hat{k}) = 3$ आणि $\vec{r} \cdot (2\hat{i} + 5\hat{j} - \alpha\hat{k}) = -1$, $\alpha \in \mathbb{R}$, तर $\alpha + |\vec{r}|^2$ चे मूल्य बरोबर _____ आहे.

Options :

8643514779. 9

8643514780. 11

8643514781. 13

8643514782. 15

Question Number : 64 Question Id : 8643511594 Question Type : MCQ Option Shuffling : Yes Is Question Mandatory : No

Correct Marks : 4 Wrong Marks : 1

Let f be a real valued function, defined on $\mathbb{R} - \{-1, 1\}$ and given by

$$f(x) = 3 \log_e \left| \frac{x-1}{x+1} \right| - \frac{2}{x-1}.$$

Then in which of the following intervals, function $f(x)$ is increasing ?

Options :

8643514783. $(-\infty, \infty) - \{-1, 1\}$

8643514784. $(-\infty, -1) \cup \left(\left[\frac{1}{2}, \infty \right) - \{1\} \right)$

8643514785. $(-\infty, \frac{1}{2}] - \{-1\}$

8643514786. $(-1, \frac{1}{2}]$

Question Number : 64 Question Id : 8643511594 Question Type : MCQ Option Shuffling : Yes Is Question Mandatory : No

Correct Marks : 4 Wrong Marks : 1

समजा f हे $\mathbb{R} - \{-1, 1\}$ वर निश्चित (defined) केलेले वास्तव मूल्यदर्शी (real valued) फल आहे आणि

$f(x) = 3 \log_e \left| \frac{x-1}{x+1} \right| - \frac{2}{x-1}$ दिलेले आहे. तर खालीलपैकी कोणत्या अंतराला (intervals) मध्ये फल

$f(x)$ वाढता आहे ?

Options :

8643514783. $(-\infty, \infty) - \{-1, 1\}$

8643514784. $(-\infty, -1) \cup \left(\left[\frac{1}{2}, \infty \right) - \{1\} \right)$

8643514785. $(-\infty, \frac{1}{2}] - \{-1\}$

8643514786. $(-1, \frac{1}{2}]$

Question Number : 65 Question Id : 8643511595 Question Type : MCQ Option Shuffling : Yes Is Question Mandatory : No Correct Marks : 4 Wrong Marks : 1

If the points of intersections of the ellipse $\frac{x^2}{16} + \frac{y^2}{b^2} = 1$ and the circle $x^2 + y^2 = 4b$, $b > 4$ lie on the curve $y^2 = 3x^2$, then b is equal to :

Options :

8643514787. 5

8643514788. 6

8643514789. 10

8643514790. 12

Question Number : 65 Question Id : 8643511595 Question Type : MCQ Option Shuffling : Yes Is Question Mandatory : No Correct Marks : 4 Wrong Marks : 1

जर विवृत्त (ellipse) $\frac{x^2}{16} + \frac{y^2}{b^2} = 1$ आणि वर्तुळ $x^2 + y^2 = 4b$, $b > 4$ यांचे छेद बिंदू $y^2 = 3x^2$ या वक्रावर स्थित (lie) असतील, तर b बरोबर _____ आहे.

Options :

8643514787. 5

8643514788. 6

8643514789. 10

8643514790. 12

Question Number : 66 Question Id : 8643511596 Question Type : MCQ Option Shuffling : Yes Is Question Mandatory : No Correct Marks : 4 Wrong Marks : 1

Let C be the locus of the mirror image of a point on the parabola $y^2=4x$ with respect to the line $y=x$. Then the equation of tangent to C at P(2, 1) is :

Options :

8643514791. $x + 3y = 5$

8643514792. $2x + y = 5$

8643514793. $x - y = 1$

8643514794. $x + 2y = 4$

Question Number : 66 Question Id : 8643511596 Question Type : MCQ Option Shuffling : Yes Is

Question Mandatory : No

Correct Marks : 4 Wrong Marks : 1

समजा C हा $y^2=4x$ या अन्वस्ता (parabola) वरील बिंदूच्या आरशातील प्रतिमे (mirror image) चे $y=x$ या रेषेच्या संदर्भातील निधान (locus) आहे. तर C च्या P(2, 1) या बिंदूशी काढलेल्या स्पर्शिकेचे समीकरण _____ आहे.

Options :

8643514791. $x + 3y = 5$

8643514792. $2x + y = 5$

8643514793. $x - y = 1$

8643514794. $x + 2y = 4$

Question Number : 67 Question Id : 8643511597 Question Type : MCQ Option Shuffling : Yes Is

Question Mandatory : No

Correct Marks : 4 Wrong Marks : 1

Let A denote the event that a 6-digit integer formed by 0, 1, 2, 3, 4, 5, 6 without repetitions, be divisible by 3. Then probability of event A is equal to :

Options :

8643514795. $\frac{4}{9}$

8643514796. $\frac{3}{7}$

8643514797. $\frac{11}{27}$

8643514798. $\frac{9}{56}$

Question Number : 67 Question Id : 8643511597 Question Type : MCQ Option Shuffling : Yes Is Question Mandatory : No Correct Marks : 4 Wrong Marks : 1

समजा A ही घटना (event) दर्शविते. या घटने मध्ये 0, 1, 2, 3, 4, 5, 6 हे अंक (digit) वापरून पुनरावृत्ती नसणारे (without repetition), 3 ने भागले (divisible) जाणारे 6-अंकी पूर्णांक संख्या तयार केल्या. तर घटना A ची संभाव्यता (probability) बरोबर _____ आहे.

Options :

8643514795. $\frac{4}{9}$

8643514796. $\frac{3}{7}$

8643514797. $\frac{11}{27}$

8643514798. $\frac{9}{56}$

Question Number : 68 Question Id : 8643511598 Question Type : MCQ Option Shuffling : Yes Is Question Mandatory : No Correct Marks : 4 Wrong Marks : 1

If $y = y(x)$ is the solution of the differential equation $\frac{dy}{dx} + (\tan x) y = \sin x$, $0 \leq x \leq \frac{\pi}{3}$, with

$y(0) = 0$, then $y\left(\frac{\pi}{4}\right)$ equal to :

Options :

8643514799. $\left(\frac{1}{2\sqrt{2}}\right) \log_e 2$

8643514800. $\frac{1}{2} \log_e 2$

8643514801. $\log_e 2$

8643514802. $\frac{1}{4} \log_e 2$

Question Number : 68 Question Id : 8643511598 Question Type : MCQ Option Shuffling : Yes Is

Question Mandatory : No

Correct Marks : 4 Wrong Marks : 1

जर $y = y(x)$ हे $\frac{dy}{dx} + (\tan x) y = \sin x, 0 \leq x \leq \frac{\pi}{3}$, या विकलक समीकरणाची (differential equation),
 $y(0) = 0$ सहीत उकल आहे, तर $y\left(\frac{\pi}{4}\right)$ बरोबर _____.

Options :

8643514799. $\left(\frac{1}{2\sqrt{2}}\right) \log_e 2$

8643514800. $\frac{1}{2} \log_e 2$

8643514801. $\log_e 2$

8643514802. $\frac{1}{4} \log_e 2$

Question Number : 69 Question Id : 8643511599 Question Type : MCQ Option Shuffling : Yes Is

Question Mandatory : No

Correct Marks : 4 Wrong Marks : 1

Let $\alpha \in \mathbb{R}$ be such that the function $f(x) = \begin{cases} \frac{\cos^{-1}(1 - \{x\}^2) \sin^{-1}(1 - \{x\})}{\{x\} - \{x\}^3}, & x \neq 0 \\ \alpha, & x = 0 \end{cases}$ is

continuous at $x=0$, where $\{x\} = x - [x]$, $[x]$ is the greatest integer less than or equal to x .
Then :

Options :

8643514803. $\alpha = 0$

8643514804. no such α exists

8643514805. $\alpha = \frac{\pi}{\sqrt{2}}$

8643514806. $\alpha = \frac{\pi}{4}$

Question Number : 69 Question Id : 8643511599 Question Type : MCQ Option Shuffling : Yes Is Question Mandatory : No

Correct Marks : 4 Wrong Marks : 1

समजा $\alpha \in \mathbb{R}$ आहे जसे की

$$f(x) = \begin{cases} \frac{\cos^{-1}(1 - \{x\}^2) \sin^{-1}(1 - \{x\})}{\{x\} - \{x\}^3}, & x \neq 0 \\ \alpha, & x = 0 \end{cases}$$

हे $x=0$ वर संतत (continuous) असणारे फल आहे, जेव्हा $\{x\} = x - [x]$, $[x]$ हे x किंवा x पेक्षा लहान असणारे महत्तम पूर्णांक (greatest integer) आहे. तर :

Options :

8643514803. $\alpha = 0$

8643514804. असा कोणताही α अस्तित्वात (exists) नाही

8643514805. $\alpha = \frac{\pi}{\sqrt{2}}$

$$\alpha = \frac{\pi}{4}$$

8643514806.

Question Number : 70 Question Id : 8643511600 Question Type : MCQ Option Shuffling : Yes Is Question Mandatory : No

Correct Marks : 4 Wrong Marks : 1

If (x, y, z) be an arbitrary point lying on a plane P which passes through the points $(42, 0, 0)$,

$(0, 42, 0)$ and $(0, 0, 42)$, then the value of the expression

$$3 + \frac{x-11}{(y-19)^2 (z-12)^2} + \frac{y-19}{(x-11)^2 (z-12)^2} + \frac{z-12}{(x-11)^2 (y-19)^2} - \frac{x+y+z}{14(x-11)(y-19)(z-12)}$$

is equal to :

Options :

8643514807. - 45

8643514808. 39

8643514809. 0

8643514810. 3

Question Number : 70 Question Id : 8643511600 Question Type : MCQ Option Shuffling : Yes Is Question Mandatory : No

Correct Marks : 4 Wrong Marks : 1

जर (x, y, z) हा कोणताही बिंदू P प्रतलावर आहे. प्रतल P हे $(42, 0, 0)$, $(0, 42, 0)$ आणि $(0, 0, 42)$ या बिंदूंना मधून जाते, तर

$$3 + \frac{x-11}{(y-19)^2 (z-12)^2} + \frac{y-19}{(x-11)^2 (z-12)^2} + \frac{z-12}{(x-11)^2 (y-19)^2} - \frac{x+y+z}{14(x-11)(y-19)(z-12)}$$

या पदावलीचे मूल्य बरोबर _____ आहे.

Options :

8643514807. - 45

8643514808. 39

8643514809. 0

8643514810. 3

Question Number : 71 Question Id : 8643511601 Question Type : MCQ Option Shuffling : Yes Is Question Mandatory : No

Correct Marks : 4 Wrong Marks : 1

Let $A = \{2, 3, 4, 5, \dots, 30\}$ and ' \simeq ' be an equivalence relation on $A \times A$, defined by $(a, b) \simeq (c, d)$, if and only if $ad = bc$. Then the number of ordered pairs which satisfy this equivalence relation with ordered pair $(4, 3)$ is equal to :

Options :

8643514811. 5

8643514812. 6

8643514813. 7

8643514814. 8

Question Number : 71 Question Id : 8643511601 Question Type : MCQ Option Shuffling : Yes Is Question Mandatory : No

Correct Marks : 4 Wrong Marks : 1

समजा $A = \{2, 3, 4, 5, \dots, 30\}$ आणि ' \simeq ' हे $A \times A$ वर सममूल्यता संबंध (equivalence relation) असून, $(a, b) \simeq (c, d)$ द्वारा निश्चित करते, जर आणि फक्त जर (if and only if) $ad = bc$. तर क्रमित जोडी. (ordered pairs) ची संख्या, जी या सममूल्यता संबंधाचे $(4, 3)$ या क्रमित जोडी सह समाधान करते, बरोबर _____ आहे.

Options :

8643514811. 5

8643514812. 6

8643514813. 7

8643514814. 8

Question Number : 72 Question Id : 8643511602 Question Type : MCQ Option Shuffling : Yes Is Question Mandatory : No Correct Marks : 4 Wrong Marks : 1

Let $P(x) = x^2 + bx + c$ be a quadratic polynomial with real coefficients such that $\int_0^1 P(x) dx = 1$ and $P(x)$ leaves remainder 5 when it is divided by $(x - 2)$. Then the value of $9(b + c)$ is equal to :

Options :

8643514815. 7

8643514816. 9

8643514817. 11

8643514818. 15

Question Number : 72 Question Id : 8643511602 Question Type : MCQ Option Shuffling : Yes Is Question Mandatory : No Correct Marks : 4 Wrong Marks : 1

समजा $P(x) = x^2 + bx + c$ ही वास्तव सहगुणकां (real coefficients) सह वर्ग बहुपदी (quadratic polynomial) आहे, जसे की $\int_0^1 P(x) dx = 1$ आणि $P(x)$ ला $(x - 2)$ ने विभाजित (divided) केले असता बाकी 5 राहते. तर $9(b + c)$ चे मूल्य बरोबर _____ आहे.

Options :

8643514815. 7

8643514816. 9

8643514817. 11

8643514818. 15

Question Number : 73 Question Id : 8643511603 Question Type : MCQ Option Shuffling : Yes Is Question Mandatory : No

Correct Marks : 4 Wrong Marks : 1

Consider a rectangle ABCD having 5, 7, 6, 9 points in the interior of the line segments AB, CD, BC, DA respectively. Let α be the number of triangles having these points from different sides as vertices and β be the number of quadrilaterals having these points from different sides as vertices. Then $(\beta - \alpha)$ is equal to :

Options :

8643514819. 1173

8643514820. 1890

8643514821. 717

8643514822. 795

Question Number : 73 Question Id : 8643511603 Question Type : MCQ Option Shuffling : Yes Is Question Mandatory : No

Correct Marks : 4 Wrong Marks : 1

एक आयत ABCD, ज्याचे रेषा खंड AB, CD, BC, DA च्या आंतर भागात अनुक्रमे 5, 7, 6, 9 बिंदू आहेत, याचा विचार करा. समजा α ही त्या त्रिकोणाची संख्या आहे, ज्याचे शिरोबिंदू भिन्न बाजूंवरील हे बिंदू आहेत आणि β ही त्या चौकोनाची (quadrilaterals) संख्या आहे ज्याचे शिरोबिंदू भिन्न बाजूंवरील हे बिंदू आहेत. तर $(\beta - \alpha)$ बरोबर _____ आहे.

Options :

8643514819. 1173

8643514820. 1890

8643514821. 717

8643514822. 795

Question Number : 74 Question Id : 8643511604 Question Type : MCQ Option Shuffling : Yes Is

Question Mandatory : No

Correct Marks : 4 Wrong Marks : 1

Consider the integral

$$I = \int_0^{10} \frac{[x] e^{[x]}}{e^{x-1}} dx,$$

where $[x]$ denotes the greatest integer less than or equal to x . Then the value of I is equal

to :

Options :

8643514823. $45 (e + 1)$

8643514824. $9 (e + 1)$

8643514825. $45 (e - 1)$

8643514826. $9 (e - 1)$

Question Number : 74 Question Id : 8643511604 Question Type : MCQ Option Shuffling : Yes Is

Question Mandatory : No

Correct Marks : 4 Wrong Marks : 1

दिलेल्या पूर्णांकी (integral) चा विचार करा.

$$I = \int_0^{10} \frac{[x] e^{[x]}}{e^{x-1}} dx,$$

जेव्हा $[x]$ हे x किंवा x पेक्षा लहान महत्तम पूर्णांक (greatest integer) दर्शविते. तर I चे मूल्य बरोबर _____ आहे.

Options :

8643514823. $45 (e + 1)$

8643514824. $9 (e + 1)$

8643514825. $45 (e - 1)$

8643514826. $9(e-1)$

Question Number : 75 Question Id : 8643511605 Question Type : MCQ Option Shuffling : Yes Is Question Mandatory : No

Correct Marks : 4 Wrong Marks : 1

Let $A(-1, 1)$, $B(3, 4)$ and $C(2, 0)$ be given three points. A line $y = mx$, $m > 0$, intersects lines AC and BC at point P and Q respectively. Let A_1 and A_2 be the areas of ΔABC and ΔPQC respectively, such that $A_1 = 3A_2$, then the value of m is equal to :

Options :

8643514827. 1

8643514828. $\frac{4}{15}$

8643514829. 2

8643514830. 3

Question Number : 75 Question Id : 8643511605 Question Type : MCQ Option Shuffling : Yes Is Question Mandatory : No

Correct Marks : 4 Wrong Marks : 1

समजा $A(-1, 1)$, $B(3, 4)$ आणि $C(2, 0)$ हे तीन बिंदू दिलेले आहेत. एक रेषा $y = mx$, $m > 0$, रेषा AC आणि BC यांना अनुक्रमे बिंदू P आणि Q मध्ये छेदते. समजा ΔABC आणि ΔPQC ची क्षेत्रफळ अनुक्रमे A_1 आणि A_2 आहेत, जसे की $A_1 = 3A_2$, तर m चे मूल्य बरोबर _____ आहे.

Options :

8643514827. 1

8643514828. $\frac{4}{15}$

8643514829. 2

8643514830. 3

Question Number : 76 Question Id : 8643511606 Question Type : MCQ Option Shuffling : Yes Is Question Mandatory : No

Correct Marks : 4 Wrong Marks : 1

The least value of $|z|$ where z is complex number which satisfies the inequality

$$\exp\left(\frac{(|z| + 3)(|z| - 1)}{|z| + 1} \log_e 2\right) \geq \log_{\sqrt{2}} |5\sqrt{7} + 9i|, i = \sqrt{-1}, \text{ is equal to :}$$

Options :

8643514831. 2

8643514832. $\sqrt{5}$

8643514833. 3

8643514834. 8

Question Number : 76 Question Id : 8643511606 Question Type : MCQ Option Shuffling : Yes Is Question Mandatory : No

Correct Marks : 4 Wrong Marks : 1

$|z|$ चे लघूत्तम मूल्य (least value) बरोबर _____ आहे. जेव्हा z ही

$$\exp\left(\frac{(|z| + 3)(|z| - 1)}{|z| + 1} \log_e 2\right) \geq \log_{\sqrt{2}} |5\sqrt{7} + 9i|, i = \sqrt{-1}$$

या असमान पदावलीचे (inequality expression) समाधान करणारी संमिश्र संख्या (complex number) आहे.

Options :

8643514831. 2

8643514832. $\sqrt{5}$

8643514833. 3

8643514834. 8

Question Number : 77 Question Id : 8643511607 Question Type : MCQ Option Shuffling : Yes Is Question Mandatory : No

Correct Marks : 4 Wrong Marks : 1

The maximum value of $f(x) = \begin{vmatrix} \sin^2 x & 1 + \cos^2 x & \cos 2x \\ 1 + \sin^2 x & \cos^2 x & \cos 2x \\ \sin^2 x & \cos^2 x & \sin 2x \end{vmatrix}$, $x \in \mathbf{R}$ is :

Options :

8643514835. $\sqrt{5}$

8643514836. 5

8643514837. $\sqrt{7}$

8643514838. $\frac{3}{4}$

Question Number : 77 Question Id : 8643511607 Question Type : MCQ Option Shuffling : Yes Is Question Mandatory : No

Correct Marks : 4 Wrong Marks : 1

$f(x) = \begin{vmatrix} \sin^2 x & 1 + \cos^2 x & \cos 2x \\ 1 + \sin^2 x & \cos^2 x & \cos 2x \\ \sin^2 x & \cos^2 x & \sin 2x \end{vmatrix}$, $x \in \mathbf{R}$ चे कमाल मूल्य (maximum value) _____

आहे.

Options :

8643514835. $\sqrt{5}$

8643514836. 5

8643514837. $\sqrt{7}$

8643514838. $\frac{3}{4}$

Question Number : 78 Question Id : 8643511608 Question Type : MCQ Option Shuffling : Yes Is Question Mandatory : No

Correct Marks : 4 Wrong Marks : 1

Given that the inverse trigonometric functions take principal values only. Then, the number of real values of x which satisfy $\sin^{-1}\left(\frac{3x}{5}\right) + \sin^{-1}\left(\frac{4x}{5}\right) = \sin^{-1}x$ is equal to :

Options :

8643514839. 0

8643514840. 1

8643514841. 2

8643514842. 3

Question Number : 78 Question Id : 8643511608 Question Type : MCQ Option Shuffling : Yes Is Question Mandatory : No

Correct Marks : 4 Wrong Marks : 1

दिलेले आहे की व्यस्त त्रिकोणमितीय फलांची (inverse trigonometric functions) फक्त प्रमुख मूल्ये (principal values) घेतली आहेत. तर, $\sin^{-1}\left(\frac{3x}{5}\right) + \sin^{-1}\left(\frac{4x}{5}\right) = \sin^{-1}x$ याचे समाधान करणाऱ्या x च्या वास्तव मूल्यांची (real values) संख्या बरोबर _____ आहे.

Options :

8643514839. 0

8643514840. 1

8643514841. 2

8643514842. 3

Question Number : 79 Question Id : 8643511609 Question Type : MCQ Option Shuffling : Yes Is Question Mandatory : No

Correct Marks : 4 Wrong Marks : 1

Let $f: S \rightarrow S$ where $S = (0, \infty)$ be a twice differentiable function such that $f(x+1) = xf(x)$. If $g: S \rightarrow \mathbb{R}$ be defined as $g(x) = \log_e f(x)$, then the value of $|g''(5) - g''(1)|$ is equal to :

Options :

$$8643514843. \frac{205}{144}$$

$$8643514844. \frac{197}{144}$$

$$8643514845. \frac{187}{144}$$

$$8643514846. 1$$

Question Number : 79 Question Id : 8643511609 Question Type : MCQ Option Shuffling : Yes Is Question Mandatory : No

Correct Marks : 4 Wrong Marks : 1

समजा $f: S \rightarrow S$ जेंव्हा $S = (0, \infty)$ हे दोन वेळेस विकलनीय फल (twice differentiable function) आहे जसे की $f(x+1) = xf(x)$. जर $g: S \rightarrow \mathbb{R}$ हे $g(x) = \log_e f(x)$ ला निश्चित करते, तर $|g''(5) - g''(1)|$ चे मूल्य बरोबर _____ आहे.

Options :

$$8643514843. \frac{205}{144}$$

$$8643514844. \frac{197}{144}$$

$$8643514845. \frac{187}{144}$$

$$8643514846. 1$$

Question Number : 80 Question Id : 8643511610 Question Type : MCQ Option Shuffling : Yes Is Question Mandatory : No

Correct Marks : 4 Wrong Marks : 1

Let C_1 be the curve obtained by the solution of differential equation $2xy \frac{dy}{dx} = y^2 - x^2, x > 0$.

Let the curve C_2 be the solution of $\frac{2xy}{x^2 - y^2} = \frac{dy}{dx}$. If both the curves pass through $(1, 1)$, then

the area enclosed by the curves C_1 and C_2 is equal to :

Options :

8643514847. $\frac{\pi}{4} + 1$

8643514848. $\pi - 1$

8643514849. $\frac{\pi}{2} - 1$

8643514850. $\pi + 1$

Question Number : 80 Question Id : 8643511610 Question Type : MCQ Option Shuffling : Yes Is Question Mandatory : No

Correct Marks : 4 Wrong Marks : 1

समजा $2xy \frac{dy}{dx} = y^2 - x^2, x > 0$ या विकलक समीकरणाची (differential equation) उकल वक्र C_1 आहे.

समजा $\frac{2xy}{x^2 - y^2} = \frac{dy}{dx}$ या विकलक समीकरणाची उकल वक्र C_2 आहे. जर दोन्ही वक्र $(1, 1)$ या बिंदूमधून जात

असतील, तर C_1 आणि C_2 या वक्रांमुळे परिबद्ध (enclosed) क्षेत्राचे क्षेत्रफल बरोबर _____ आहे.

Options :

8643514847. $\frac{\pi}{4} + 1$

8643514848. $\pi - 1$

8643514849. $\frac{\pi}{2} - 1$

Mathematics Section B

Section Id :	864351108
Section Number :	6
Section type :	Online
Mandatory or Optional :	Mandatory
Number of Questions :	10
Number of Questions to be attempted :	5
Section Marks :	20
Mark As Answered Required? :	Yes
Sub-Section Number :	1
Sub-Section Id :	864351108
Question Shuffling Allowed :	Yes

Question Number : 81 Question Id : 8643511611 Question Type : SA

Correct Marks : 4 Wrong Marks : 0

For real numbers α , β , γ and δ , if

$$\int \frac{(x^2-1) + \tan^{-1}\left(\frac{x^2+1}{x}\right)}{(x^4+3x^2+1) \tan^{-1}\left(\frac{x^2+1}{x}\right)} dx$$

$$= \alpha \log_e \left(\tan^{-1} \left(\frac{x^2+1}{x} \right) \right) + \beta \tan^{-1} \left(\frac{\gamma(x^2-1)}{x} \right) + \delta \tan^{-1} \left(\frac{x^2+1}{x} \right) + C$$

where C is an arbitrary constant, then the value of $10(\alpha + \beta\gamma + \delta)$ is equal to _____.

Response Type : Numeric

Evaluation Required For SA : Yes

Show Word Count : Yes

Answers Type : Equal

Text Areas : PlainText

Possible Answers :

100

Question Number : 81 Question Id : 8643511611 Question Type : SA

Correct Marks : 4 Wrong Marks : 0

α, β, γ आणि δ या वास्तव संख्ये साठी, जर

$$\int \frac{(x^2-1) + \tan^{-1}\left(\frac{x^2+1}{x}\right)}{(x^4+3x^2+1) \tan^{-1}\left(\frac{x^2+1}{x}\right)} dx$$
$$= \alpha \log_e \left(\tan^{-1} \left(\frac{x^2+1}{x} \right) \right) + \beta \tan^{-1} \left(\frac{\gamma(x^2-1)}{x} \right) + \delta \tan^{-1} \left(\frac{x^2+1}{x} \right) + C$$

जेव्हा C हा कोणताही अचल (arbitrary constant) आहे. तर $10(\alpha + \beta\gamma + \delta)$ चे मूल्य बरोबर _____ आहे.

Response Type : Numeric

Evaluation Required For SA : Yes

Show Word Count : Yes

Answers Type : Equal

Text Areas : PlainText

Possible Answers :

100

Question Number : 82 **Question Id :** 8643511612 **Question Type :** SA

Correct Marks : 4 **Wrong Marks :** 0

In ΔABC , the lengths of sides AC and AB are 12 cm and 5 cm, respectively. If the area of ΔABC is 30 cm^2 and R and r are respectively the radii of circumcircle and incircle of ΔABC , then the value of $2R + r$ (in cm) is equal to _____.

Response Type : Numeric

Evaluation Required For SA : Yes

Show Word Count : Yes

Answers Type : Equal

Text Areas : PlainText

Possible Answers :

100

Question Number : 82 **Question Id :** 8643511612 **Question Type :** SA

Correct Marks : 4 **Wrong Marks :** 0

एका ΔABC मध्ये, AC आणि AB या बाजूंची लांबी अनुक्रमे 12 से.मी. आणि 5 से.मी. आहेत. जर ΔABC चे क्षेत्रफळ 30 (से.मी.)² आहे आणि ΔABC च्या परिवर्तुळ (circumcircle) आणि आंतरवर्तुळ (incircle) यांच्या त्रिज्या अनुक्रमे R आणि r आहे. तर $2R + r$ (से.मी. मध्ये) चे मूल्य बरोबर _____ आहे.

Response Type : Numeric

Evaluation Required For SA : Yes

Show Word Count : Yes

Answers Type : Equal

Text Areas : PlainText

Possible Answers :

100

Question Number : 83 **Question Id :** 8643511613 **Question Type :** SA

Correct Marks : 4 **Wrong Marks :** 0

If the distance of the point $(1, -2, 3)$ from the plane $x + 2y - 3z + 10 = 0$ measured parallel to

the line, $\frac{x-1}{3} = \frac{2-y}{m} = \frac{z+3}{1}$ is $\sqrt{\frac{7}{2}}$, then the value of $|m|$ is equal to _____.

Response Type : Numeric

Evaluation Required For SA : Yes

Show Word Count : Yes

Answers Type : Equal

Text Areas : PlainText

Possible Answers :

100

Question Number : 83 **Question Id :** 8643511613 **Question Type :** SA

Correct Marks : 4 **Wrong Marks :** 0

जर $(1, -2, 3)$ या बिंदूचे $\frac{x-1}{3} = \frac{2-y}{m} = \frac{z+3}{1}$ या रेषेला समांतर असणाऱ्या $x + 2y - 3z + 10 = 0$ या

प्रतलापासून मोजलेले अंतर $\sqrt{\frac{7}{2}}$ आहे, तर $|m|$ चे मूल्य बरोबर _____ आहे.

Response Type : Numeric

Evaluation Required For SA : Yes

Show Word Count : Yes

Answers Type : Equal

Text Areas : PlainText

Possible Answers :

100

Question Number : 84 Question Id : 8643511614 Question Type : SA

Correct Marks : 4 Wrong Marks : 0

Let \vec{c} be a vector perpendicular to the vectors $\vec{a} = \hat{i} + \hat{j} - \hat{k}$ and $\vec{b} = \hat{i} + 2\hat{j} + \hat{k}$. If

$\vec{c} \cdot (\hat{i} + \hat{j} + 3\hat{k}) = 8$ then the value of $\vec{c} \cdot (\vec{a} \times \vec{b})$ is equal to _____.

Response Type : Numeric

Evaluation Required For SA : Yes

Show Word Count : Yes

Answers Type : Equal

Text Areas : PlainText

Possible Answers :

100

Question Number : 84 Question Id : 8643511614 Question Type : SA

Correct Marks : 4 Wrong Marks : 0

समजा \vec{c} हे $\vec{a} = \hat{i} + \hat{j} - \hat{k}$ आणि $\vec{b} = \hat{i} + 2\hat{j} + \hat{k}$ या सदिशांना (vectors) लंब (perpendicular)

असणारे सदिश आहे. जर $\vec{c} \cdot (\hat{i} + \hat{j} + 3\hat{k}) = 8$, तर $\vec{c} \cdot (\vec{a} \times \vec{b})$ चे मूल्य बरोबर _____ आहे.

Response Type : Numeric

Evaluation Required For SA : Yes

Show Word Count : Yes

Answers Type : Equal

Text Areas : PlainText

Possible Answers :

100

Question Number : 85 Question Id : 8643511615 Question Type : SA

Correct Marks : 4 Wrong Marks : 0

Let $f: \mathbb{R} \rightarrow \mathbb{R}$ and $g: \mathbb{R} \rightarrow \mathbb{R}$ be defined as

$$f(x) = \begin{cases} x + a, & x < 0 \\ |x - 1|, & x \geq 0 \end{cases} \text{ and } g(x) = \begin{cases} x + 1, & x < 0 \\ (x - 1)^2 + b, & x \geq 0 \end{cases}$$

where a, b are non-negative real numbers. If $(g \circ f)(x)$ is continuous for all $x \in \mathbb{R}$, then $a + b$ is equal to _____.

Response Type : Numeric

Evaluation Required For SA : Yes

Show Word Count : Yes

Answers Type : Equal

Text Areas : PlainText

Possible Answers :

100

Question Number : 85 Question Id : 8643511615 Question Type : SA

Correct Marks : 4 Wrong Marks : 0

समजा $f: \mathbb{R} \rightarrow \mathbb{R}$ आणि $g: \mathbb{R} \rightarrow \mathbb{R}$

$$f(x) = \begin{cases} x+a, & x < 0 \\ |x-1|, & x \geq 0 \end{cases} \text{ आणि } g(x) = \begin{cases} x+1, & x < 0 \\ (x-1)^2+b, & x \geq 0 \end{cases}$$

द्वारे निश्चित करते. जेव्हा a, b हे ऋण नसलेले (non-negative) वास्तव संख्या आहेत. जर $(g \circ f)(x)$ हे सर्व $x \in \mathbb{R}$ साठी संतत (continuous) आहे, तर $a+b$ बरोबर _____ आहे.

Response Type : Numeric

Evaluation Required For SA : Yes

Show Word Count : Yes

Answers Type : Equal

Text Areas : PlainText

Possible Answers :

100

Question Number : 86 Question Id : 8643511616 Question Type : SA

Correct Marks : 4 Wrong Marks : 0

Consider the statistics of two sets of observations as follows :

	Size	Mean	Variance
Observation I	10	2	2
Observation II	n	3	1

If the variance of the combined set of these two observations is $\frac{17}{9}$, then the value of n is

equal to _____.

Response Type : Numeric

Evaluation Required For SA : Yes

Show Word Count : Yes

Answers Type : Equal

Text Areas : PlainText

Possible Answers :

100

Question Number : 86 Question Id : 8643511616 Question Type : SA

Correct Marks : 4 Wrong Marks : 0

खाली दिलेल्या 2 संचाच्या निरीक्षणाच्या (observations) संख्याशास्त्राचा (statistics) विचार करा :

	आकार (Size)	मध्य (Mean)	प्रचरण (Variance)
निरीक्षण I	10	2	2
निरीक्षण II	n	3	1

जर या दोन निरीक्षणांच्या एकत्रित (combined) संचाचे प्रचरण $\frac{17}{9}$ आहे, तर n चे मूल्य बरोबर _____ आहे.

Response Type : Numeric

Evaluation Required For SA : Yes

Show Word Count : Yes

Answers Type : Equal

Text Areas : PlainText

Possible Answers :

100

Question Number : 87 Question Id : 8643511617 Question Type : SA

Correct Marks : 4 Wrong Marks : 0

Let n be a positive integer. Let $A = \sum_{k=0}^n (-1)^k nC_k \left[\left(\frac{1}{2}\right)^k + \left(\frac{3}{4}\right)^k + \left(\frac{7}{8}\right)^k + \left(\frac{15}{16}\right)^k + \left(\frac{31}{32}\right)^k \right]$

If $63A = 1 - \frac{1}{2^{30}}$, then n is equal to _____.

Response Type : Numeric

Evaluation Required For SA : Yes

Show Word Count : Yes

Answers Type : Equal

Text Areas : PlainText

Possible Answers :

100

Question Number : 87 Question Id : 8643511617 Question Type : SA

Correct Marks : 4 Wrong Marks : 0

समजा n हा धन पूर्णांक (positive integer) आहे.

$$\text{समजा } A = \sum_{k=0}^n (-1)^k nC_k \left[\left(\frac{1}{2}\right)^k + \left(\frac{3}{4}\right)^k + \left(\frac{7}{8}\right)^k + \left(\frac{15}{16}\right)^k + \left(\frac{31}{32}\right)^k \right]$$

जर $63A = 1 - \frac{1}{2^{30}}$, तर n बरोबर _____ आहे.

Response Type : Numeric

Evaluation Required For SA : Yes

Show Word Count : Yes

Answers Type : Equal

Text Areas : PlainText

Possible Answers :

100

Question Number : 88 **Question Id :** 8643511618 **Question Type :** SA

Correct Marks : 4 **Wrong Marks :** 0

Let $A = \begin{bmatrix} a_1 \\ a_2 \end{bmatrix}$ and $B = \begin{bmatrix} b_1 \\ b_2 \end{bmatrix}$ be two 2×1 matrices with real entries such that $A = XB$, where

$X = \frac{1}{\sqrt{3}} \begin{bmatrix} 1 & -1 \\ 1 & k \end{bmatrix}$, and $k \in \mathbb{R}$. If $a_1^2 + a_2^2 = \frac{2}{3}(b_1^2 + b_2^2)$ and $(k^2 + 1) b_2^2 \neq -2 b_1 b_2$, then the

value of k is _____.

Response Type : Numeric

Evaluation Required For SA : Yes

Show Word Count : Yes

Answers Type : Equal

Text Areas : PlainText

Possible Answers :

100

Question Number : 88 **Question Id :** 8643511618 **Question Type :** SA

Correct Marks : 4 **Wrong Marks :** 0

समजा $A = \begin{bmatrix} a_1 \\ a_2 \end{bmatrix}$ आणि $B = \begin{bmatrix} b_1 \\ b_2 \end{bmatrix}$ या दोन 2×1 च्या सारण्या आहेत जसे की $A = XB$, जेव्हा

$X = \frac{1}{\sqrt{3}} \begin{bmatrix} 1 & -1 \\ 1 & k \end{bmatrix}$, आणि $k \in \mathbb{R}$ जर $a_1^2 + a_2^2 = \frac{2}{3}(b_1^2 + b_2^2)$ आणि $(k^2 + 1) b_2^2 \neq -2 b_1 b_2$, तर k चे

मूल्य _____ आहे.

Response Type : Numeric

Evaluation Required For SA : Yes

Show Word Count : Yes

Answers Type : Equal

Text Areas : PlainText

Possible Answers :

100

Question Number : 89 **Question Id :** 8643511619 **Question Type :** SA

Correct Marks : 4 **Wrong Marks :** 0

Let $\frac{1}{16}$, a and b be in G.P. and $\frac{1}{a}$, $\frac{1}{b}$, 6 be in A.P., where $a, b > 0$. Then $72(a + b)$ is equal to

_____.

Response Type : Numeric

Evaluation Required For SA : Yes

Show Word Count : Yes

Answers Type : Equal

Text Areas : PlainText

Possible Answers :

100

Question Number : 89 **Question Id :** 8643511619 **Question Type :** SA

Correct Marks : 4 **Wrong Marks :** 0

समजा $\frac{1}{16}$, a आणि b हे भूमिती श्रेढी (G.P.) मध्ये आहेत आणि $\frac{1}{a}$, $\frac{1}{b}$, 6 हे गणित श्रेढी (A.P.) मध्ये

आहेत, जेव्हा $a, b > 0$, तर $72(a + b)$ बरोबर _____ आहे.

Response Type : Numeric

Evaluation Required For SA : Yes

Show Word Count : Yes

Answers Type : Equal

Text Areas : PlainText

Possible Answers :

100

Question Number : 90 Question Id : 8643511620 Question Type : SA

Correct Marks : 4 Wrong Marks : 0

Let

$$S_n(x) = \log_{a/2} x + \log_{a/3} x + \log_{a/6} x + \log_{a/11} x + \log_{a/18} x + \log_{a/27} x + \dots \text{ up to n-terms,}$$

where $a > 1$. If $S_{24}(x) = 1093$ and $S_{12}(2x) = 265$, then value of a is equal to _____.

Response Type : Numeric

Evaluation Required For SA : Yes

Show Word Count : Yes

Answers Type : Equal

Text Areas : PlainText

Possible Answers :

100

Question Number : 90 Question Id : 8643511620 Question Type : SA

Correct Marks : 4 Wrong Marks : 0

समजा $S_n(x) = \log_{a/2} x + \log_{a/3} x + \log_{a/6} x + \log_{a/11} x$
 $+ \log_{a/18} x + \log_{a/27} x + \dots \dots n$ पदा पर्यंत

जेव्हा $a > 1$. जर $S_{24}(x) = 1093$ आणि $S_{12}(2x) = 265$, तर a चे मूल्य बरोबर _____ आहे.

Response Type : Numeric

Evaluation Required For SA : Yes

Show Word Count : Yes

Answers Type : Equal

Text Areas : PlainText

Possible Answers :

100