

National Testing Agency

Question Paper Name :	B TECH EM 17th March 2021 Shift 1
Subject Name :	B TECH EM
Creation Date :	2021-03-17 15:29:45
Duration :	180
Number of Questions :	90
Total Marks :	300
Display Marks:	Yes

B TECH EM

Group Number :	1
Group Id :	86435130
Group Maximum Duration :	0
Group Minimum Duration :	180
Show Attended Group? :	No
Edit Attended Group? :	No
Break time :	0
Group Marks :	300
Is this Group for Examiner? :	No

Physics Section A

Section Id :	864351175
Section Number :	1
Section type :	Online
Mandatory or Optional :	Mandatory
Number of Questions :	20
Number of Questions to be attempted :	20
Section Marks :	80
Mark As Answered Required? :	Yes
Sub-Section Number :	1
Sub-Section Id :	864351175
Question Shuffling Allowed :	Yes

Question Number : 1 Question Id : 8643512611 Question Type : MCQ Option Shuffling : Yes Is Question Mandatory : No Correct Marks : 4 Wrong Marks : 1

A car accelerates from rest at a constant rate α for some time after which it decelerates at a constant rate β to come to rest. If the total time elapsed is t seconds, the total distance travelled is :

Options :

8643517831. $\frac{2 \alpha \beta}{(\alpha + \beta)} t^2$

8643517832. $\frac{\alpha \beta}{2(\alpha + \beta)} t^2$

8643517833. $\frac{4 \alpha \beta}{(\alpha + \beta)} t^2$

8643517834. $\frac{\alpha \beta}{4(\alpha + \beta)} t^2$

Question Number : 1 Question Id : 8643512611 Question Type : MCQ Option Shuffling : Yes Is Question Mandatory : No

Correct Marks : 4 Wrong Marks : 1

एक गाडी स्थिरतेपासून काही वेळ α एवढ्या स्थिर दराने त्वरणीत होते व नंतर β स्थिर दराने अवत्वरण होऊन स्थिर होते. जर एकूण लागलेला वेळ t सेकंद आहे, एकूण पार केलेले अंतर _____ आहे.

Options :

8643517831. $\frac{2 \alpha \beta}{(\alpha + \beta)} t^2$

8643517832. $\frac{\alpha \beta}{2(\alpha + \beta)} t^2$

8643517833. $\frac{4 \alpha \beta}{(\alpha + \beta)} t^2$

8643517834. $\frac{\alpha \beta}{4(\alpha + \beta)} t^2$

Question Number : 2 Question Id : 8643512612 Question Type : MCQ Option Shuffling : Yes Is Question Mandatory : No

Correct Marks : 4 Wrong Marks : 1

A modern grand - prix racing car of mass m is travelling on a flat track in a circular arc of radius R with a speed v . If the coefficient of static friction between the tyres and the track is μ_s , then the magnitude of negative lift F_L acting downwards on the car is : (Assume forces on the four tyres are identical and g = acceleration due to gravity)

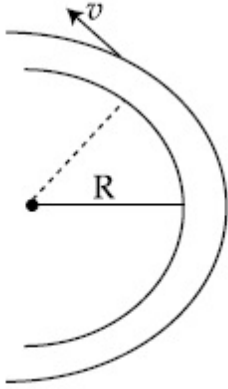

Options :

8643517835. $m \left(\frac{v^2}{\mu_s R} + g \right)$

8643517836. $m \left(g - \frac{v^2}{\mu_s R} \right)$

8643517837. $m \left(\frac{v^2}{\mu_s R} - g \right)$

8643517838. $- m \left(g + \frac{v^2}{\mu_s R} \right)$

Question Number : 2 Question Id : 8643512612 Question Type : MCQ Option Shuffling : Yes Is Question Mandatory : No

Correct Marks : 4 Wrong Marks : 1

एक आधुनिक शर्यतीतील गाडीचे वस्तुमान m असून ती v वेगाने R त्रिज्येच्या वर्तुळाकार चापाच्या सरळ रस्त्यावरून प्रवास करीत आहे. जर टायर व रस्ता यामधील स्थितिक घर्षण गुणांक μ_s आहे तर गाडीवर खालील दिशेत कार्य करणाऱ्या ऋण बलाची F_L किंमत _____ आहे. (असे माना कि चारही टायर्सवरील बल सारखेच आहे व $g =$ गुरुत्वीय त्वरण)

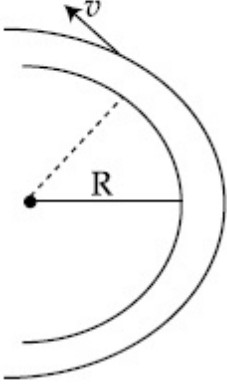

Options :

$$m \left(\frac{v^2}{\mu_s R} + g \right)$$

8643517835.

$$m \left(g - \frac{v^2}{\mu_s R} \right)$$

8643517836.

$$m \left(\frac{v^2}{\mu_s R} - g \right)$$

8643517837.

$$- m \left(g + \frac{v^2}{\mu_s R} \right)$$

8643517838.

Question Number : 3 Question Id : 8643512613 Question Type : MCQ Option Shuffling : Yes Is Question Mandatory : No

Correct Marks : 4 Wrong Marks : 1

A Carnot's engine working between 400 K and 800 K has a work output of 1200 J per cycle. The amount of heat energy supplied to the engine from the source in each cycle is :

Options :

8643517839. 2400 J

8643517840. 1600 J

8643517841. 3200 J

8643517842. 1800 J

Question Number : 3 Question Id : 8643512613 Question Type : MCQ Option Shuffling : Yes Is Question Mandatory : No

Correct Marks : 4 Wrong Marks : 1

कारनॉटचे अभियंत्र 400 K व 800 K मध्ये कार्य करित असून निष्पन्न कार्य एका चक्रासाठी 1200 J आहे. प्रत्येक चक्रासाठी उद्गमाने अभियंत्रास पुरवठा केलेली उष्मा ऊर्जा _____ आहे.

Options :

8643517839. 2400 J

8643517840. 1600 J

8643517841. 3200 J

8643517842. 1800 J

Question Number : 4 Question Id : 8643512614 Question Type : MCQ Option Shuffling : Yes Is Question Mandatory : No

Correct Marks : 4 Wrong Marks : 1

A solenoid of 1000 turns per metre has a core with relative permeability 500. Insulated windings of the solenoid carry an electric current of 5 A. The magnetic flux density produced by the solenoid is : (permeability of free space = $4\pi \times 10^{-7}$ H/m)

Options :

8643517843. $10^{-4}\pi$ T8643517844. $2 \times 10^{-3}\pi$ T8643517845. $\frac{\pi}{5}$ T

8643517846. πT

Question Number : 4 Question Id : 8643512614 Question Type : MCQ Option Shuffling : Yes Is Question Mandatory : No

Correct Marks : 4 Wrong Marks : 1

एका मिटरमध्ये 1000 वेढे असलेल्या सोलेनॉइडच्या आतील भागातील सापेक्ष पर्यता 500 आहे. सोलेनॉइडच्या रोधित कुंडलन 5 A विद्युत धारा वाहून नेते. सोलेनॉइडने तयार केलेली चुंबकीय अभिवाह घनता _____ आहे. (मुक्त वातावरणातील पर्यता $= 4\pi \times 10^{-7} \text{ H/m}$)

Options :

8643517843. $10^{-4}\pi T$

8643517844. $2 \times 10^{-3}\pi T$

8643517845. $\frac{\pi}{5} T$

8643517846. πT

Question Number : 5 Question Id : 8643512615 Question Type : MCQ Option Shuffling : Yes Is Question Mandatory : No

Correct Marks : 4 Wrong Marks : 1

A current of 10 A exists in a wire of crosssectional area of 5 mm² with a drift velocity of $2 \times 10^{-3} \text{ ms}^{-1}$. The number of free electrons in each cubic meter of the wire is _____.

Options :

8643517847. 2×10^6

8643517848. 1×10^{23}

8643517849. 625×10^{25}

8643517850. 2×10^{25}

Question Number : 5 Question Id : 8643512615 Question Type : MCQ Option Shuffling : Yes Is

Question Mandatory : No

Correct Marks : 4 Wrong Marks : 1

5 mm² क्रॉससेक्शनल क्षेत्रफळ असलेल्या तारेतून 10 A एवढी धारा आहे तर अपवहन वेग $2 \times 10^{-3} \text{ m s}^{-1}$ आहे. ह्या तारेतील प्रत्येक घन मीटरमधील मुक्त इलेक्ट्रॉन्सची संख्या _____ आहे.

Options :

8643517847. 2×10^6

8643517848. 1×10^{23}

8643517849. 625×10^{25}

8643517850. 2×10^{25}

Question Number : 6 Question Id : 8643512616 Question Type : MCQ Option Shuffling : Yes Is Question Mandatory : No

Correct Marks : 4 Wrong Marks : 1

A mass M hangs on a massless rod of length l which rotates at a constant angular frequency. The mass M moves with steady speed in a circular path of constant radius. Assume that the system is in steady circular motion with constant angular velocity ω . The angular momentum of M about point A is L_A which lies in the positive z direction and the angular momentum of M about point B is L_B . The correct statement for this system is :

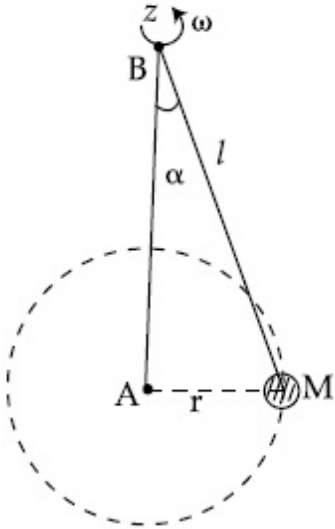

Options :

8643517851. L_A and L_B are both constant in magnitude and direction

8643517852. L_A is constant, both in magnitude and direction

8643517853. L_B is constant, both in magnitude and direction

8643517854. L_B is constant in direction with varying magnitude

Question Number : 6 Question Id : 8643512616 Question Type : MCQ Option Shuffling : Yes Is Question Mandatory : No

Correct Marks : 4 Wrong Marks : 1

l लांबीच्या वजनविरहीत दांड्यास M वस्तुमान टांगलेले आहे जे स्थिर कोनिय वेगाने घूर्णन करित आहे. M वस्तुमान स्थिर वेगाने वर्तुळाकार पथावरून स्थिर त्रिज्येने गतिमान आहे असे माना कि संहती स्थिर वर्तुळाकार गतित ω एवढ्या स्थिर कोनिय वेगाने गतिमान आहे. M चा A बिंदूवर कोनिय संवेग L_A आहे जो घन z दिशेत आहे व M चा B बिंदूवर कोनिय संवेग L_B आहे. ह्या संहतीसाठी योग्य विधान _____ आहे.

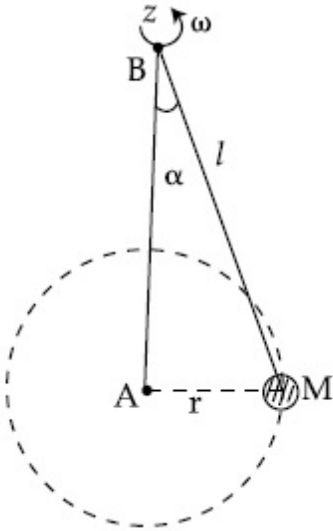

Options :

8643517851. L_A व L_B दोन्ही किंमतीत व दिशेत स्थिर आहेत.

8643517852. L_A स्थिर आहे, दोन्हीत किंमत व दिशा

8643517853. L_B स्थिर आहे, दोन्हीत किंमत व दिशा

8643517854. L_B दिशेत स्थिर आहे पण बदलत्या किंमतीत

Question Number : 7 Question Id : 8643512617 Question Type : MCQ Option Shuffling : Yes Is

Question Mandatory : No

Correct Marks : 4 Wrong Marks : 1

An AC current is given by $I = I_1 \sin \omega t + I_2 \cos \omega t$. A hot wire ammeter will give a reading :

Options :

8643517855. $\frac{I_1 + I_2}{\sqrt{2}}$

8643517856. $\frac{I_1 + I_2}{2\sqrt{2}}$

8643517857. $\sqrt{\frac{I_1^2 + I_2^2}{2}}$

8643517858. $\sqrt{\frac{I_1^2 - I_2^2}{2}}$

Question Number : 7 Question Id : 8643512617 Question Type : MCQ Option Shuffling : Yes Is

Question Mandatory : No

Correct Marks : 4 Wrong Marks : 1

प्रत्यावर्ती धारा $I = I_1 \sin \omega t + I_2 \cos \omega t$ अशी दिलेली आहे. गरम तार असलेला अॅमीटर _____ वाचन देईल.

Options :

8643517855. $\frac{I_1 + I_2}{\sqrt{2}}$

8643517856. $\frac{I_1 + I_2}{2\sqrt{2}}$

8643517857. $\sqrt{\frac{I_1^2 + I_2^2}{2}}$

8643517858. $\sqrt{\frac{I_1^2 - I_2^2}{2}}$

Question Number : 8 Question Id : 8643512618 Question Type : MCQ Option Shuffling : Yes Is Question Mandatory : No

Correct Marks : 4 Wrong Marks : 1

A polyatomic ideal gas has 24 vibrational modes. What is the value of γ ?

Options :

8643517859. 10.3

8643517860. 1.30

8643517861. 1.03

8643517862. 1.37

Question Number : 8 Question Id : 8643512618 Question Type : MCQ Option Shuffling : Yes Is Question Mandatory : No

Correct Marks : 4 Wrong Marks : 1

बहुअणू आदर्श वायूस 24 कंपनिक प्रकार आहेत. γ चे मूल्य किती आहे?

Options :

8643517859. 10.3

8643517860. 1.30

8643517861. 1.03

8643517862. 1.37

Question Number : 9 Question Id : 8643512619 Question Type : MCQ Option Shuffling : Yes Is Question Mandatory : No

Correct Marks : 4 Wrong Marks : 1

When two soap bubbles of radii a and b ($b > a$) coalesce, the radius of curvature of common surface is :

Options :

8643517863. $\frac{ab}{b-a}$

$$8643517864. \quad \frac{ab}{a+b}$$

$$8643517865. \quad \frac{b-a}{ab}$$

$$8643517866. \quad \frac{a+b}{ab}$$

Question Number : 9 Question Id : 8643512619 Question Type : MCQ Option Shuffling : Yes Is Question Mandatory : No

Correct Marks : 4 Wrong Marks : 1

जेव्हा a व b ($b > a$) त्रिज्येचे दोन साबणाचे फुगे एकत्र येतात, सामायिक पृष्ठभागाची वक्रता त्रिज्या _____ आहे.

Options :

$$8643517863. \quad \frac{ab}{b-a}$$

$$8643517864. \quad \frac{ab}{a+b}$$

$$8643517865. \quad \frac{b-a}{ab}$$

$$8643517866. \quad \frac{a+b}{ab}$$

Question Number : 10 Question Id : 8643512620 Question Type : MCQ Option Shuffling : Yes Is Question Mandatory : No

Correct Marks : 4 Wrong Marks : 1

A triangular plate is shown. A force $\vec{F} = 4\hat{i} - 3\hat{j}$ is applied at point P. The torque at point P with respect to point 'O' and 'Q' are :

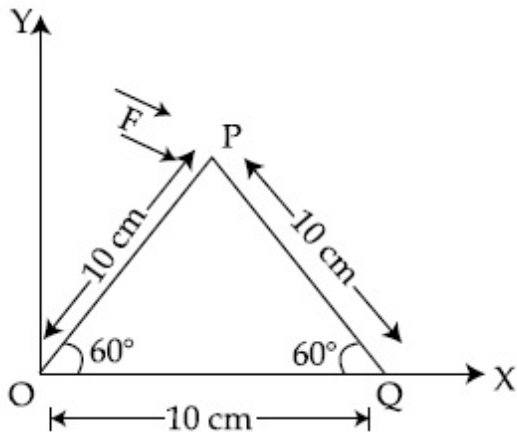

Options :

8643517867. $-15 - 20\sqrt{3}, 15 - 20\sqrt{3}$

8643517868. $15 + 20\sqrt{3}, 15 - 20\sqrt{3}$

8643517869. $15 - 20\sqrt{3}, 15 + 20\sqrt{3}$

8643517870. $-15 + 20\sqrt{3}, 15 + 20\sqrt{3}$

Question Number : 10 Question Id : 8643512620 Question Type : MCQ Option Shuffling : Yes Is

Question Mandatory : No

Correct Marks : 4 Wrong Marks : 1

त्रिकोणी पट्टी दाखविली आहे. P बिंदूवर $\vec{F} = 4\hat{i} - 3\hat{j}$ बल लावले आहे. 'O' व 'Q' संबंधित P बिंदूवरील आघूर्ण _____ आहे.

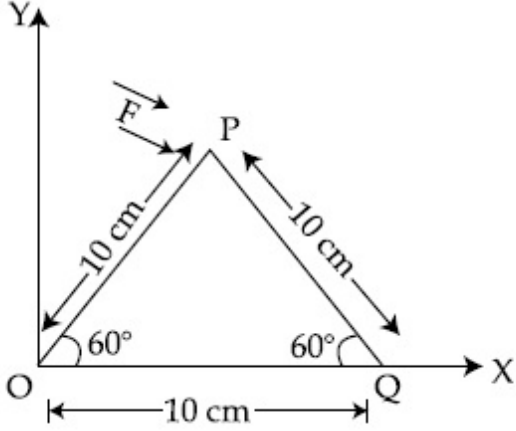

Options :

8643517867. $-15 - 20\sqrt{3}, 15 - 20\sqrt{3}$

8643517868. $15 + 20\sqrt{3}, 15 - 20\sqrt{3}$

8643517869. $15 - 20\sqrt{3}, 15 + 20\sqrt{3}$

8643517870. $-15 + 20\sqrt{3}, 15 + 20\sqrt{3}$

Question Number : 11 Question Id : 8643512621 Question Type : MCQ Option Shuffling : Yes Is Question Mandatory : No

Correct Marks : 4 Wrong Marks : 1

Two identical metal wires of thermal conductivities K_1 and K_2 respectively are connected in series. The effective thermal conductivity of the combination is :

Options :

8643517871. $\frac{K_1 K_2}{K_1 + K_2}$

8643517872. $\frac{2K_1 K_2}{K_1 + K_2}$

8643517873. $\frac{K_1 + K_2}{2K_1 K_2}$

$$\frac{K_1 + K_2}{K_1 K_2}$$

8643517874.

Question Number : 11 Question Id : 8643512621 Question Type : MCQ Option Shuffling : Yes Is Question Mandatory : No

Correct Marks : 4 Wrong Marks : 1

दोन एकसारख्या धातुच्या तारा ज्यांची औष्णिक वाहकता K_1 व K_2 अनुक्रमे आहे अशा एकसरीत जोडल्या आहेत. संयुक्तीक परिणामी औष्णिक वाहकता _____ आहे.

Options :

$$\frac{K_1 K_2}{K_1 + K_2}$$

8643517871.

$$\frac{2K_1 K_2}{K_1 + K_2}$$

8643517872.

$$\frac{K_1 + K_2}{2K_1 K_2}$$

8643517873.

$$\frac{K_1 + K_2}{K_1 K_2}$$

8643517874.

Question Number : 12 Question Id : 8643512622 Question Type : MCQ Option Shuffling : Yes Is Question Mandatory : No

Correct Marks : 4 Wrong Marks : 1

A boy is rolling a 0.5 kg ball on the frictionless floor with the speed of 20 ms^{-1} . The ball gets deflected by an obstacle on the way. After deflection it moves with 5% of its initial kinetic energy. What is the speed of the ball now ?

Options :

$$1.00 \text{ ms}^{-1}$$

8643517875.

$$4.47 \text{ ms}^{-1}$$

8643517876.

$$14.41 \text{ ms}^{-1}$$

8643517877.

8643517878. 19.0 ms^{-1}

Question Number : 12 Question Id : 8643512622 Question Type : MCQ Option Shuffling : Yes Is

Question Mandatory : No

Correct Marks : 4 Wrong Marks : 1

एक मुलगा 0.5 kg चा चेंडू घर्षणविरहीत जमीनीवरून 20 ms^{-1} वेगाने घरंगळत सोडत आहे. जाताना चेंडू अडथळ्यामुळे बाजूला जात आहे. बाजूला जाऊन सुरुवातीच्या गतिज ऊर्जेच्या 5% ने जातो. आता चेंडूचा वेग किती आहे?

Options :

8643517875. 1.00 ms^{-1}

8643517876. 4.47 ms^{-1}

8643517877. 14.41 ms^{-1}

8643517878. 19.0 ms^{-1}

Question Number : 13 Question Id : 8643512623 Question Type : MCQ Option Shuffling : Yes Is

Question Mandatory : No

Correct Marks : 4 Wrong Marks : 1

The thickness at the centre of a plano convex lens is 3 mm and the diameter is 6 cm. If the speed of light in the material of the lens is $2 \times 10^8 \text{ ms}^{-1}$. The focal length of the lens is _____.

Options :

8643517879. 30 cm

8643517880. 15 cm

8643517881. 1.5 cm

8643517882. 0.30 cm

Question Number : 13 Question Id : 8643512623 Question Type : MCQ Option Shuffling : Yes Is

Question Mandatory : No

Correct Marks : 4 Wrong Marks : 1

एका समतल बहिर्वक्र भिंगाच्या मध्याची जाडी 3 mm व व्यास 6 cm आहे. जर भिंगाच्या पदार्थातील प्रकाशाचा वेग $2 \times 10^8 \text{ ms}^{-1}$ आहे, भिंगाची नाभीय लांबी _____ आहे.

Options :

8643517879. 30 cm

8643517880. 15 cm

8643517881. 1.5 cm

8643517882. 0.30 cm

Question Number : 14 Question Id : 8643512624 Question Type : MCQ Option Shuffling : Yes Is Question Mandatory : No

Correct Marks : 4 Wrong Marks : 1

Which level of the single ionized carbon has the same energy as the ground state energy of hydrogen atom ?

Options :

8643517883. 1

8643517884. 4

8643517885. 6

8643517886. 8

Question Number : 14 Question Id : 8643512624 Question Type : MCQ Option Shuffling : Yes Is Question Mandatory : No

Correct Marks : 4 Wrong Marks : 1

एक आयनित कार्बनची ऊर्जा, हायड्रोजन अणूच्या तळाच्या स्थिति एवढीच आहे, तर पातळी कोणती आहे?

Options :

8643517883. 1

8643517884. 4

8643517885. ⁶8643517886. ⁸**Question Number : 15 Question Id : 8643512625 Question Type : MCQ Option Shuffling : Yes Is****Question Mandatory : No****Correct Marks : 4 Wrong Marks : 1**

Two ideal polyatomic gases at temperatures T_1 and T_2 are mixed so that there is no loss of energy. If F_1 and F_2 , m_1 and m_2 , n_1 and n_2 be the degrees of freedom, masses, number of molecules of the first and second gas respectively, the temperature of mixture of these two gases is :

Options :

$$8643517887. \quad \frac{n_1 F_1 T_1 + n_2 F_2 T_2}{n_1 + n_2}$$

$$8643517888. \quad \frac{n_1 F_1 T_1 + n_2 F_2 T_2}{F_1 + F_2}$$

$$8643517889. \quad \frac{n_1 F_1 T_1 + n_2 F_2 T_2}{n_1 F_1 + n_2 F_2}$$

$$8643517890. \quad \frac{n_1 T_1 + n_2 T_2}{n_1 + n_2}$$

Question Number : 15 Question Id : 8643512625 Question Type : MCQ Option Shuffling : Yes Is**Question Mandatory : No****Correct Marks : 4 Wrong Marks : 1**

दोन आदर्श बहुअण्विक वायू T_1 व T_2 तापमानास मिसळले असे कि ऊर्जेचे नुकसान झाले नाही. जर F_1 व F_2 , m_1 व m_2 , n_1 व n_2 ह्या मुक्तता कोटी, वस्तुमाने, रेणूंची संख्या अनुक्रमे पहिल्या व दूसऱ्या वायूसाठी आहेत. दोन वायूंच्या मिश्रणाचे तापमान _____ आहे.

Options :

$$8643517887. \quad \frac{n_1 F_1 T_1 + n_2 F_2 T_2}{n_1 + n_2}$$

$$\frac{n_1 F_1 T_1 + n_2 F_2 T_2}{F_1 + F_2}$$

8643517888.

$$\frac{n_1 F_1 T_1 + n_2 F_2 T_2}{n_1 F_1 + n_2 F_2}$$

8643517889.

$$\frac{n_1 T_1 + n_2 T_2}{n_1 + n_2}$$

8643517890.

Question Number : 16 Question Id : 8643512626 Question Type : MCQ Option Shuffling : Yes Is Question Mandatory : No

Correct Marks : 4 Wrong Marks : 1

For what value of displacement the kinetic energy and potential energy of a simple harmonic oscillation become equal ?

Options :

8643517891. $x = \pm A$

8643517892. $x = 0$

8643517893. $x = \pm \frac{A}{\sqrt{2}}$

8643517894. $x = \frac{A}{2}$

Question Number : 16 Question Id : 8643512626 Question Type : MCQ Option Shuffling : Yes Is Question Mandatory : No

Correct Marks : 4 Wrong Marks : 1

कोणत्या विस्थापनाच्या किंमतीसाठी सरल आवर्त दोलनाची गतिज ऊर्जा व स्थितिज ऊर्जा सारखी होईल?

Options :

8643517891. $x = \pm A$

8643517892. $x = 0$

$$x = \pm \frac{A}{\sqrt{2}}$$

8643517893.

$$x = \frac{A}{2}$$

8643517894.

Question Number : 17 Question Id : 8643512627 Question Type : MCQ Option Shuffling : Yes Is Question Mandatory : No

Correct Marks : 4 Wrong Marks : 1

The output of the given combination gates represents :

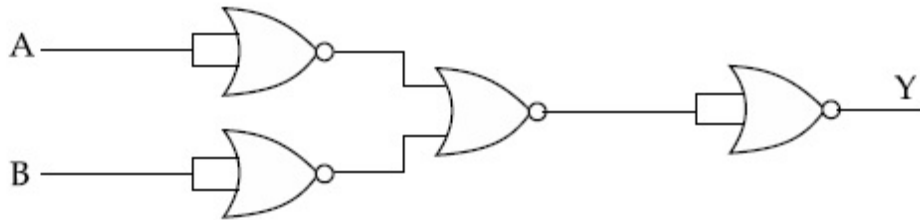

Options :

8643517895. AND Gate

8643517896. NOR Gate

8643517897. NAND Gate

8643517898. XOR Gate

Question Number : 17 Question Id : 8643512627 Question Type : MCQ Option Shuffling : Yes Is Question Mandatory : No

Correct Marks : 4 Wrong Marks : 1

दिलेल्या द्वारांच्या एकत्रिकरणासाठी निष्पन्न _____ आहे.

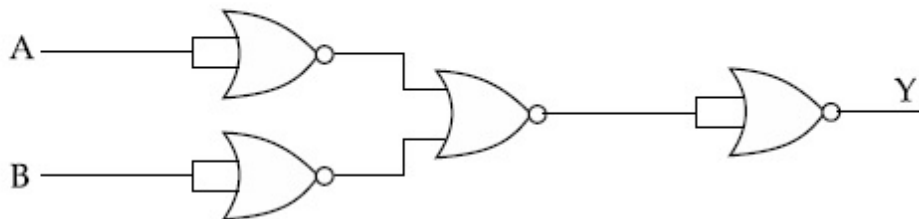

Options :

8643517895. AND द्वार

8643517896. NOR द्वार

8643517897. NAND द्वार

8643517898. XOR द्वार

Question Number : 18 Question Id : 8643512628 Question Type : MCQ Option Shuffling : Yes Is Question Mandatory : No

Correct Marks : 4 Wrong Marks : 1

An electron of mass m and a photon have same energy E . The ratio of wavelength of electron to that of photon is : (c being the velocity of light)

Options :

8643517899. $\left(\frac{E}{2m}\right)^{1/2}$

8643517900. $c (2mE)^{1/2}$

8643517901. $\frac{1}{c} \left(\frac{2m}{E}\right)^{1/2}$

8643517902. $\frac{1}{c} \left(\frac{E}{2m}\right)^{1/2}$

Question Number : 18 Question Id : 8643512628 Question Type : MCQ Option Shuffling : Yes Is Question Mandatory : No

Correct Marks : 4 Wrong Marks : 1

m वस्तुमानाच्या इलेक्ट्रॉनची व फोटॉनची ऊर्जा E सारखीच आहे. इलेक्ट्रॉनच्या तरंगलांबीचे फोटॉन बरोबरचे गुणोत्तर _____ आहे. (c -प्रकाशाचा वेग आहे)

Options :

8643517899. $\left(\frac{E}{2m}\right)^{1/2}$

8643517900. $c (2mE)^{1/2}$

$$\frac{1}{c} \left(\frac{2m}{E} \right)^{1/2}$$

8643517901.

$$\frac{1}{c} \left(\frac{E}{2m} \right)^{1/2}$$

8643517902.

Question Number : 19 Question Id : 8643512629 Question Type : MCQ Option Shuffling : Yes Is

Question Mandatory : No

Correct Marks : 4 Wrong Marks : 1

The vernier scale used for measurement has a positive zero error of 0.2 mm. If while taking a measurement it was noted that '0' on the vernier scale lies between 8.5 cm and 8.6 cm, vernier coincidence is 6, then the correct value of measurement is _____ cm. (least count = 0.01 cm)

Options :

8643517903. 8.58 cm

8643517904. 8.56 cm

8643517905. 8.54 cm

8643517906. 8.36 cm

Question Number : 19 Question Id : 8643512629 Question Type : MCQ Option Shuffling : Yes Is

Question Mandatory : No

Correct Marks : 4 Wrong Marks : 1

मोजण्यासाठी वापरलेल्या व्हर्नियर श्रेणीसाठी घन शून्य त्रुटी 0.2 mm आहे. जेव्हा मोजणी केली तेव्हा असे होते कि व्हर्नियर श्रेणीतील '0' हा 8.5 cm व 8.6 cm मध्ये आहे, व्हर्नियर संपाती 6 आहे तर मोजणीची योग्य किंमत _____ cm आहे. (लघुत्तम मापांक = 0.01 cm)

Options :

8643517903. 8.58 cm

8643517904. 8.56 cm

8643517905. 8.54 cm

8643517906. 8.36 cm

Question Number : 20 Question Id : 8643512630 Question Type : MCQ Option Shuffling : Yes Is Question Mandatory : No

Correct Marks : 4 Wrong Marks : 1

If an electron is moving in the n^{th} orbit of the hydrogen atom, then its velocity (v_n) for the n^{th} orbit is given as :

Options :

8643517907. $v_n \propto n^2$

8643517908. $v_n \propto n$

8643517909. $v_n \propto \frac{1}{n^2}$

8643517910. $v_n \propto \frac{1}{n}$

Question Number : 20 Question Id : 8643512630 Question Type : MCQ Option Shuffling : Yes Is Question Mandatory : No

Correct Marks : 4 Wrong Marks : 1

जर हायड्रोजन अणूमधील इलेक्ट्रॉन n^{th} कक्षेत गतिमान आहे तर n^{th} कक्षेसाठी वेग (v_n) असा दिला आहे

Options :

8643517907. $v_n \propto n^2$

8643517908. $v_n \propto n$

8643517909. $v_n \propto \frac{1}{n^2}$

$$v_n \propto \frac{1}{n}$$

8643517910.

Physics Section B

Section Id :	864351176
Section Number :	2
Section type :	Online
Mandatory or Optional :	Mandatory
Number of Questions :	10
Number of Questions to be attempted :	5
Section Marks :	20
Mark As Answered Required? :	Yes
Sub-Section Number :	1
Sub-Section Id :	864351176
Question Shuffling Allowed :	Yes

Question Number : 21 Question Id : 8643512631 Question Type : SA

Correct Marks : 4 Wrong Marks : 0

For VHF signal broadcasting, _____ km² of maximum service area will be covered by an antenna tower of height 30 m, if the receiving antenna is placed at ground. Let radius of the earth be 6400 km. (Round off to the Nearest Integer) (Take π as 3.14)

Response Type : Numeric

Evaluation Required For SA : Yes

Show Word Count : Yes

Answers Type : Equal

Text Areas : PlainText

Possible Answers :

100

Question Number : 21 Question Id : 8643512631 Question Type : SA

Correct Marks : 4 Wrong Marks : 0

VHF संकेत प्रसारणासाठी, उंचीच्या अँटेना टॉवरने 30 m _____ km² एवढी महत्तम सेवा क्षेत्रफळ पूर्ण केले आहे, जर ग्राही अँटेना तळावर ठेवली, पृथ्वीची त्रिज्या 6400 km आहे. (जवळच्या पूर्णांकापर्यंत) ($\pi = 3.14$ असे घ्या)

Response Type : Numeric

Evaluation Required For SA : Yes

Show Word Count : Yes

Answers Type : Equal

Text Areas : PlainText

Possible Answers :

100

Question Number : 22 Question Id : 8643512632 Question Type : SA

Correct Marks : 4 Wrong Marks : 0

If 2.5×10^{-6} N average force is exerted by a light wave on a non - reflecting surface of 30 cm^2 area during 40 minutes of time span, the energy flux of light just before it falls on the surface is _____ W/cm^2 . (Round off to the Nearest Integer)

(Assume complete absorption and normal incidence conditions are there)

Response Type : Numeric

Evaluation Required For SA : Yes

Show Word Count : Yes

Answers Type : Equal

Text Areas : PlainText

Possible Answers :

100

Question Number : 22 Question Id : 8643512632 Question Type : SA

Correct Marks : 4 Wrong Marks : 0

जर 40 मिनिटांच्या वेळेत 30 cm^2 परावर्तित न करणाऱ्या पृष्ठभागाच्या क्षेत्रफळावर प्रकाश तरंगाने सरासरी बल 2.5×10^{-6} N लावले. प्रकाशाची अभिवाह ऊर्जा जेव्हा नुकतीच पृष्ठभागावर पडते ती _____ W/cm^2 आहे. (जवळच्या पूर्णांकापर्यंत) (असे माना कि संपूर्ण अवशोषण व साधारण आपाती अटी आहेत)

Response Type : Numeric

Evaluation Required For SA : Yes

Show Word Count : Yes

Answers Type : Equal

Text Areas : PlainText

Possible Answers :

100

Question Number : 23 Question Id : 8643512633 Question Type : SA

Correct Marks : 4 Wrong Marks : 0

Four identical rectangular plates with length, $l = 2$ cm and breadth, $b = \frac{3}{2}$ cm are arranged as shown in figure. The equivalent capacitance between A and C is $\frac{x\epsilon_0}{d}$. The value of x is _____ . (Round off to the Nearest Integer)

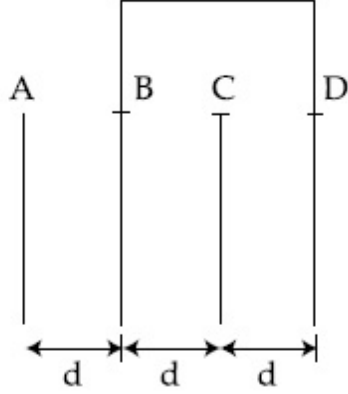

Response Type : Numeric

Evaluation Required For SA : Yes

Show Word Count : Yes

Answers Type : Equal

Text Areas : PlainText

Possible Answers :

100

Question Number : 23 **Question Id :** 8643512633 **Question Type :** SA

Correct Marks : 4 **Wrong Marks :** 0

चार एकसारख्या आयताकृती पट्ट्या, $l = 2$ cm लांबीच्या व $b = \frac{3}{2}$ cm रुंदीच्या आकृतीत दाखविल्या आहेत.

A व C मधील समतुल्य धारकता $\frac{x\epsilon_0}{d}$ आहे. x चे मूल्य _____ आहे. (जवळच्या पूर्णांकापर्यंत)

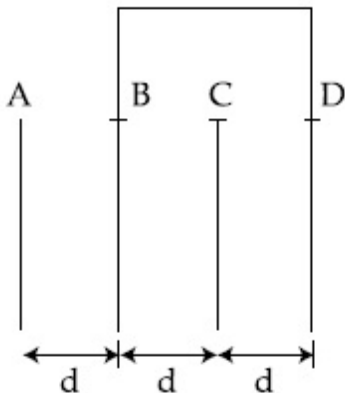

Response Type : Numeric

Evaluation Required For SA : Yes

Show Word Count : Yes

Answers Type : Equal

Text Areas : PlainText

Possible Answers :

100

Question Number : 24 Question Id : 8643512634 Question Type : SA

Correct Marks : 4 Wrong Marks : 0

The equivalent resistance of series combination of two resistors is 's'. When they are connected in parallel, the equivalent resistance is 'p'. If $s = np$, then the minimum value for n is _____. (Round off to the Nearest Integer)

Response Type : Numeric

Evaluation Required For SA : Yes

Show Word Count : Yes

Answers Type : Equal

Text Areas : PlainText

Possible Answers :

100

Question Number : 24 Question Id : 8643512634 Question Type : SA

Correct Marks : 4 Wrong Marks : 0

दोन रोध एकसरीत जोडून त्यांचा समतुल्य रोध 's' आहे. जेव्हा ते समांतर जोडले, समतुल्य रोध 'p' आहे. जर $s = np$, तर n चे कमीतकमी मूल्य _____ आहे.

Response Type : Numeric

Evaluation Required For SA : Yes

Show Word Count : Yes

Answers Type : Equal

Text Areas : PlainText

Possible Answers :

100

Question Number : 25 Question Id : 8643512635 Question Type : SA

Correct Marks : 4 Wrong Marks : 0

A parallel plate capacitor whose capacitance C is 14 pF is charged by a battery to a potential difference $V = 12$ V between its plates. The charging battery is now disconnected and a porcelain plate with $k = 7$ is inserted between the plates, then the plate would oscillate back and forth between the plates with a constant mechanical energy of _____ pJ.

(Assume no friction)

Response Type : Numeric

Evaluation Required For SA : Yes

Show Word Count : Yes

Answers Type : Equal

Text Areas : PlainText

Possible Answers :

100

Question Number : 25 Question Id : 8643512635 Question Type : SA

Correct Marks : 4 Wrong Marks : 0

समांतर पट्टी संधारित्र ज्याची धारकता $C = 14 \text{ pF}$ आहे ते बॅटरीने प्रभारित केले असे की पट्ट्यांमधील विभवांतर $V = 12 \text{ V}$ होईल. प्रभारित करणारी बॅटरी नंतर सोडून टाकली व पोर्सेलीनची पट्टी ज्याचा $k = 7$ आहे ती पट्ट्यांमध्ये सरकविली, नंतर ती पट्टी पट्ट्यांमध्ये मागे व पुढे दोलन करित राहिली जेथे स्थिर यांत्रिक ऊर्जा _____ pJ आहे. (घर्षण नाही असे माना)

Response Type : Numeric

Evaluation Required For SA : Yes

Show Word Count : Yes

Answers Type : Equal

Text Areas : PlainText

Possible Answers :

100

Question Number : 26 Question Id : 8643512636 Question Type : SA

Correct Marks : 4 Wrong Marks : 0

The radius in kilometer to which the present radius of earth ($R = 6400 \text{ km}$) to be compressed so that the escape velocity is increased 10 times is _____ .

Response Type : Numeric

Evaluation Required For SA : Yes

Show Word Count : Yes

Answers Type : Equal

Text Areas : PlainText

Possible Answers :

100

Question Number : 26 Question Id : 8643512636 Question Type : SA

Correct Marks : 4 Wrong Marks : 0

पृथ्वीची सध्याची त्रिज्या ($R = 6400 \text{ km}$) संपिडीत अशी केली कि मोचन वेग 10 पटीने वाढला तेव्हा km मध्ये त्रिज्या _____ आहे.

Response Type : Numeric

Evaluation Required For SA : Yes

Show Word Count : Yes

Answers Type : Equal

Text Areas : PlainText

Possible Answers :

100

Question Number : 27 Question Id : 8643512637 Question Type : SA

Correct Marks : 4 Wrong Marks : 0

The angular speed of truck wheel is increased from 900 rpm to 2460 rpm in 26 seconds. The number of revolutions by the truck engine during this time is _____.

(Assuming the acceleration to be uniform).

Response Type : Numeric

Evaluation Required For SA : Yes

Show Word Count : Yes

Answers Type : Equal

Text Areas : PlainText

Possible Answers :

100

Question Number : 27 Question Id : 8643512637 Question Type : SA

Correct Marks : 4 Wrong Marks : 0

ट्रकच्या चाकाचा कोनिय वेग 26 सेकंदात 900 rpm पासून 2460 rpm पर्यंत वाढविला. त्या वेळात ट्रकच्या अभियंत्राने केलेली परिभ्रमण संख्या _____. (त्वरण एकसमान आहे असे माना)

Response Type : Numeric

Evaluation Required For SA : Yes

Show Word Count : Yes

Answers Type : Equal

Text Areas : PlainText

Possible Answers :

100

Question Number : 28 Question Id : 8643512638 Question Type : SA

Correct Marks : 4 Wrong Marks : 0

Consider two identical springs each of spring constant k and negligible mass compared to the mass M as shown. Fig. 1 shows one of them and Fig. 2 shows their series combination.

The ratios of time period of oscillation of the two SHM is $T_b/T_a = \sqrt{x}$, where value of x is

..... (Round off to the Nearest Integer)

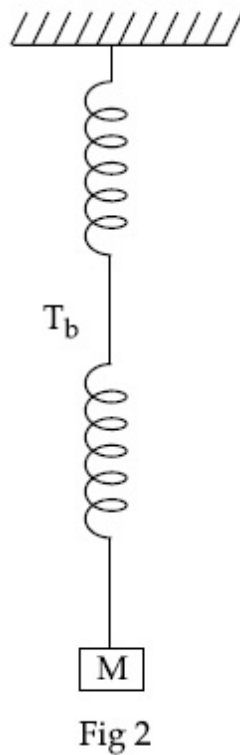
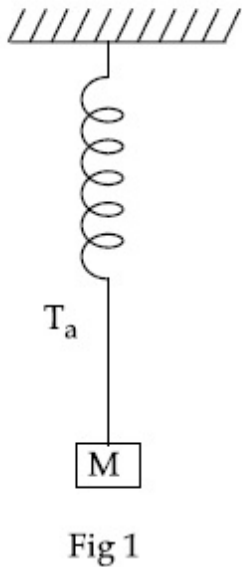

Response Type : Numeric

Evaluation Required For SA : Yes

Show Word Count : Yes

Answers Type : Equal

Text Areas : PlainText

Possible Answers :

100

Question Number : 28 **Question Id :** 8643512638 **Question Type :** SA

Correct Marks : 4 **Wrong Marks :** 0

दाखविल्याप्रमाणे दोन एकसारख्या स्प्रिंगचा स्प्रिंग स्थिरांक k असून M वस्तुमानापेक्षा स्प्रिंगचे वस्तुमान नगण्य आहे. आकृती 1 त्यापैकी एक आहे व आकृती 2 त्यांचे एकसरीतील संयोग दाखविते. दोन सरल आवर्त गतितील दोलनांच्या कालाचे गुणोत्तर $T_b/T_a = \sqrt{x}$ आहे. जेथे x चे मूल्य _____ . (जवळच्या पूर्णांकापर्यंत)

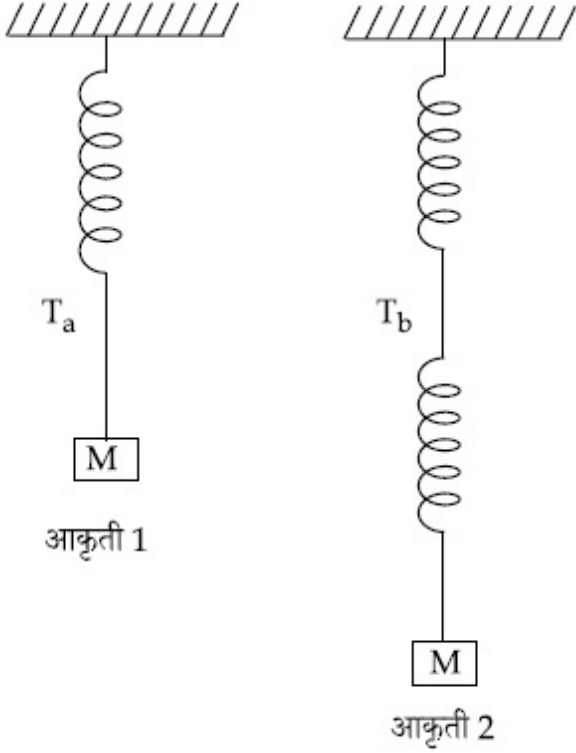

Response Type : Numeric

Evaluation Required For SA : Yes

Show Word Count : Yes

Answers Type : Equal

Text Areas : PlainText

Possible Answers :

100

Question Number : 29 **Question Id :** 8643512639 **Question Type :** SA

Correct Marks : 4 **Wrong Marks :** 0

The following bodies,

- (1) a ring
- (2) a disc
- (3) a solid cylinder
- (4) a solid sphere,

of same mass ' m ' and radius ' R ' are allowed to roll down without slipping simultaneously from the top of the inclined plane. The body which will reach first at the bottom of the inclined plane is _____.

[Mark the body as per their respective numbering given in the question]

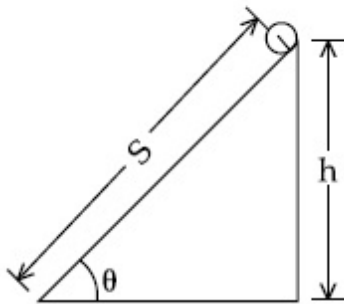

Response Type : Numeric

Evaluation Required For SA : Yes

Show Word Count : Yes

Answers Type : Equal

Text Areas : PlainText

Possible Answers :

100

Question Number : 29 **Question Id :** 8643512639 **Question Type :** SA

Correct Marks : 4 **Wrong Marks :** 0

खालील वस्तू

- (1) कडे
- (2) तबकडी
- (3) भरीव नळकांडे
- (4) भरीव गोळा

ह्यांचे वस्तुमान 'm' व त्रिज्या 'R' सारखीच असून त्या युगपततेने (आनत प्रतलाच्या शिखरावरून) न घसरता खाली घरंगळत येत आहेत. आनत प्रतलाच्या तळाशी पोहोचणारी पहिली वस्तू _____ आहे. (प्रश्नात दिल्याप्रमाणे त्या वस्तुंचा आपआपला अंक खूण करा.)

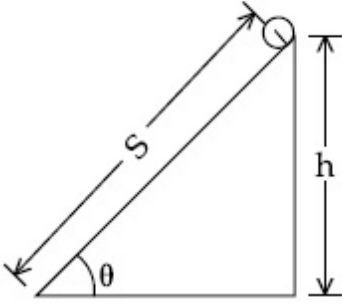

Response Type : Numeric

Evaluation Required For SA : Yes

Show Word Count : Yes

Answers Type : Equal

Text Areas : PlainText

Possible Answers :

100

Question Number : 30 **Question Id :** 8643512640 **Question Type :** SA

Correct Marks : 4 **Wrong Marks :** 0

Two blocks ($m=0.5$ kg and $M=4.5$ kg) are arranged on a horizontal frictionless table as shown in figure. The coefficient of static friction between the two blocks is $\frac{3}{7}$. Then the maximum horizontal force that can be applied on the larger block so that the blocks move together is _____ N. (Round off to the Nearest Integer) [Take g as 9.8 ms^{-2}]

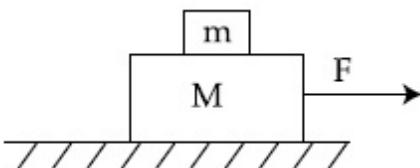

Response Type : Numeric**Evaluation Required For SA :** Yes**Show Word Count :** Yes**Answers Type :** Equal**Text Areas :** PlainText**Possible Answers :**

100

Question Number : 30 Question Id : 8643512640 Question Type : SA**Correct Marks : 4 Wrong Marks : 0**

दोन ठोकळे ($m = 0.5 \text{ kg}$ व $M = 4.5 \text{ kg}$) घर्षणविरहित क्षितिजसमांतर टेबलवर ठेवले आहेत असे दाखविले आहे. दोन ठोकळ्यांमधील स्थितिज घर्षण गुणांक $\frac{3}{7}$ आहे. दोनही ठोकळे एकत्रित गतिमान होण्यासाठी मोठ्या ठोकळ्यावर लावलेले महत्तम क्षितिजसमांतर बल _____ N आहे. (जवळच्या पूर्णांकापर्यंत)

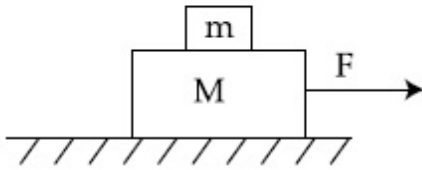
[$g = 9.8 \text{ ms}^{-2}$ घ्या]**Response Type :** Numeric**Evaluation Required For SA :** Yes**Show Word Count :** Yes**Answers Type :** Equal**Text Areas :** PlainText**Possible Answers :**

100

Chemistry Section A

Section Id :	864351177
Section Number :	3
Section type :	Online
Mandatory or Optional :	Mandatory
Number of Questions :	20
Number of Questions to be attempted :	20
Section Marks :	80
Mark As Answered Required? :	Yes
Sub-Section Number :	1
Sub-Section Id :	864351177
Question Shuffling Allowed :	Yes

Question Number : 31 Question Id : 8643512641 Question Type : MCQ Option Shuffling : Yes Is Question Mandatory : No Correct Marks : 4 Wrong Marks : 1

A central atom in a molecule has two lone pairs of electrons and forms three single bonds. The shape of this molecule is :

Options :

8643517921. planar triangular

8643517922. T-shaped

8643517923. see-saw

8643517924. trigonal pyramidal

Question Number : 31 Question Id : 8643512641 Question Type : MCQ Option Shuffling : Yes Is Question Mandatory : No Correct Marks : 4 Wrong Marks : 1

एका संयुगातील केंद्रीय अणुवर दोन विविक्त इलेक्ट्रॉन युग्मे आहेत व तो तीन एकल बंध तयार करतो. त्या संयुगाचा आकार _____ आहे.

Options :

8643517921. प्रतलीय त्रिकोणाकृती

8643517922. T-आकार

8643517923. सी-साँ

8643517924. ट्रायगोनल पिरॅमिडल

Question Number : 32 Question Id : 8643512642 Question Type : MCQ Option Shuffling : Yes Is Question Mandatory : No Correct Marks : 4 Wrong Marks : 1

A colloidal system consisting of a gas dispersed in a solid is called a/an :

Options :

8643517925. aerosol

8643517926. solid sol

8643517927. foam

8643517928. gel

Question Number : 32 Question Id : 8643512642 Question Type : MCQ Option Shuffling : Yes Is Question Mandatory : No

Correct Marks : 4 Wrong Marks : 1

एका वायूच्या घनामध्ये अपस्करण झालेल्या कलिल समूहाला _____ म्हणतात.

Options :

8643517925. एरोसॉल

8643517926. घन सॉल

8643517927. फेस (फोम)

8643517928. जेल

Question Number : 33 Question Id : 8643512643 Question Type : MCQ Option Shuffling : Yes Is Question Mandatory : No

Correct Marks : 4 Wrong Marks : 1

The absolute value of the electron gain enthalpy of halogens satisfies :

Options :

8643517929. $F > Cl > Br > I$

8643517930. $Cl > F > Br > I$

8643517931. $Cl > Br > F > I$

8643517932. $I > Br > Cl > F$

Question Number : 33 Question Id : 8643512643 Question Type : MCQ Option Shuffling : Yes Is Question Mandatory : No

Correct Marks : 4 Wrong Marks : 1

हॅलोजन्सच्या इलेक्ट्रॉन गेन एन्थॅल्पीचे केवल मूल्य _____ दर्शविते.

Options :

8643517929. $F > Cl > Br > I$

8643517930. $Cl > F > Br > I$

8643517931. $Cl > Br > F > I$

8643517932. $I > Br > Cl > F$

Question Number : 34 Question Id : 8643512644 Question Type : MCQ Option Shuffling : Yes Is Question Mandatory : No

Correct Marks : 4 Wrong Marks : 1

The point of intersection and sudden increase in the slope, in the diagram given below, respectively, indicates :

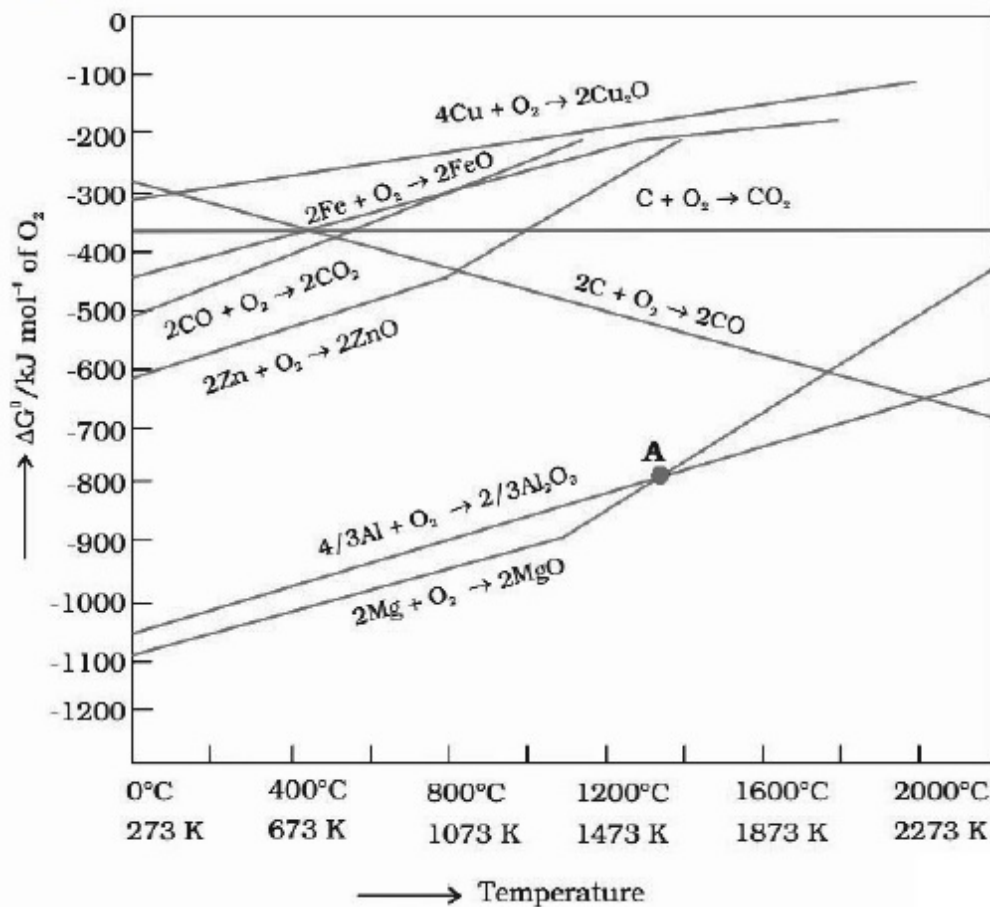

Options :

8643517933. $\Delta G < 0$ and decomposition of the metal oxide

8643517934. $\Delta G > 0$ and decomposition of the metal oxide

8643517935. $\Delta G = 0$ and melting or boiling point of the metal oxide

8643517936. $\Delta G = 0$ and reduction of the metal oxide

Question Number : 34 Question Id : 8643512644 Question Type : MCQ Option Shuffling : Yes Is Question Mandatory : No

Correct Marks : 4 Wrong Marks : 1

खालील आकृतीत छेदबिंदू आणि एकदम वाढणारा चढ अनुक्रमे _____ दर्शवितात.

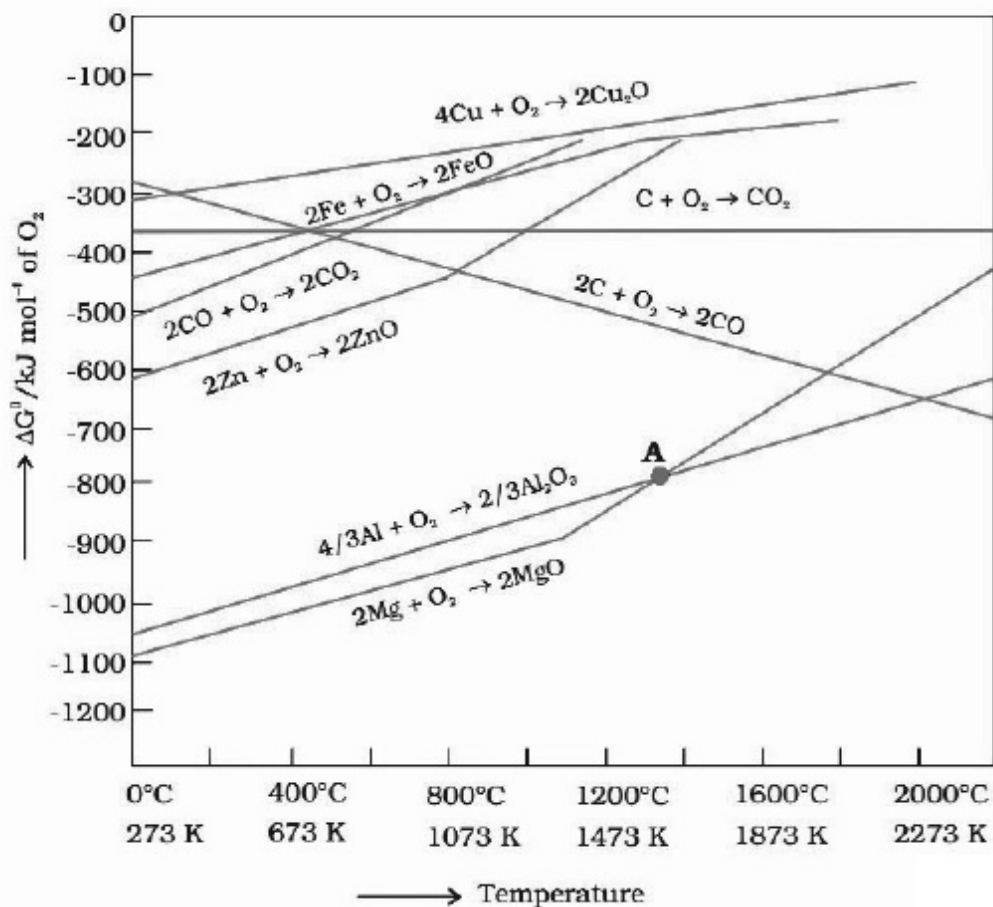

Options :

8643517933. $\Delta G < 0$ आणि धातुच्या ऑक्साइडचे विघटन

8643517934. $\Delta G > 0$ आणि धातुच्या ऑक्साइडचे विघटन

8643517935. $\Delta G = 0$ आणि धातुच्या ऑक्साइडचा द्रवणांक अथवा उत्कलनांक

8643517936. $\Delta G = 0$ आणि धातुच्या ऑक्साइडचे क्षपण

Question Number : 35 Question Id : 8643512645 Question Type : MCQ Option Shuffling : Yes Is Question Mandatory : No

Correct Marks : 4 Wrong Marks : 1

The **INCORRECT** statement(s) about heavy water is (are)

- (A) used as a moderator in nuclear reactor
- (B) obtained as a by-product in fertilizer industry
- (C) used for the study of reaction mechanism
- (D) has a higher dielectric constant than water

Choose the correct answer from the options given below :

Options :

8643517937. (C) only

8643517938. (B) only

8643517939. (D) only

8643517940. (B) and (D) only

Question Number : 35 Question Id : 8643512645 Question Type : MCQ Option Shuffling : Yes Is Question Mandatory : No

Correct Marks : 4 Wrong Marks : 1

जड पाण्यासंदर्भातील चुकीचे/चुकीची विधान/विधाने _____ आहे/आहेत.

- (A) न्यूक्लीय भट्टीत नियामक म्हणून वापरतात.
- (B) खतांच्या कारखान्यांतून उप-उत्पाद म्हणून मिळते.
- (C) अभिक्रियेच्या क्रिया-विधिच्या अभ्यासात उपयोगात येते.
- (D) पाण्यापेक्षा त्याचा पराविद्युत स्थिरांक जास्त आहे.

खाली दिलेल्या पर्यायातून योग्य उत्तर निवडा.

Options :

8643517937. फक्त (C)

8643517938. फक्त (B)

8643517939. फक्त (D)

8643517940. फक्त (B) आणि (D)

Question Number : 36 Question Id : 8643512646 Question Type : MCQ Option Shuffling : Yes Is Question Mandatory : No

Correct Marks : 4 Wrong Marks : 1

The correct order of conductivity of ions in water is :

Options :

8643517941. $\text{Cs}^+ > \text{Rb}^+ > \text{K}^+ > \text{Na}^+$

8643517942. $\text{Na}^+ > \text{K}^+ > \text{Rb}^+ > \text{Cs}^+$

8643517943. $\text{K}^+ > \text{Na}^+ > \text{Cs}^+ > \text{Rb}^+$

8643517944. $\text{Rb}^+ > \text{Na}^+ > \text{K}^+ > \text{Li}^+$

Question Number : 36 Question Id : 8643512646 Question Type : MCQ Option Shuffling : Yes Is Question Mandatory : No

Correct Marks : 4 Wrong Marks : 1

पाण्यातील आयनांच्या वाहकतेचा बरोबर क्रम _____ आहे.

Options :

8643517941. $\text{Cs}^+ > \text{Rb}^+ > \text{K}^+ > \text{Na}^+$

8643517942. $\text{Na}^+ > \text{K}^+ > \text{Rb}^+ > \text{Cs}^+$

8643517943. $\text{K}^+ > \text{Na}^+ > \text{Cs}^+ > \text{Rb}^+$

8643517944. $\text{Rb}^+ > \text{Na}^+ > \text{K}^+ > \text{Li}^+$

Question Number : 37 Question Id : 8643512647 Question Type : MCQ Option Shuffling : Yes Is Question Mandatory : No

Correct Marks : 4 Wrong Marks : 1

Which of the following compound CANNOT act as a Lewis base ?

Options :

8643517945. ClF_3

8643517946. PCl_5

8643517947. NF_3

8643517948. SF_4

Question Number : 37 Question Id : 8643512647 Question Type : MCQ Option Shuffling : Yes Is Question Mandatory : No

Correct Marks : 4 Wrong Marks : 1

खालीलपैकी कोणते संयुग लेविस आम्लारी म्हणून काम करत नाही ?

Options :

8643517945. ClF_3

8643517946. PCl_5

8643517947. NF_3

8643517948. SF_4

Question Number : 38 Question Id : 8643512648 Question Type : MCQ Option Shuffling : Yes Is Question Mandatory : No

Correct Marks : 4 Wrong Marks : 1

What is the spin-only magnetic moment value (BM) of a divalent metal ion with atomic number 25, in its aqueous solution ?

Options :

8643517949. 5.0

8643517950. 5.26

8643517951. 5.92

8643517952. zero

Question Number : 38 Question Id : 8643512648 Question Type : MCQ Option Shuffling : Yes Is Question Mandatory : No

Correct Marks : 4 Wrong Marks : 1

एका अणू अंक 25 असणाऱ्या द्विसंयुजी धातुच्या आयनाचा पाण्यातील द्रावणातील स्पीन-फक्त (BM) चुंबकीय आघूर्णाची किंमत किती आहे ?

Options :

8643517949. 5.0

8643517950. 5.26

8643517951. 5.92

8643517952. शून्य

Question Number : 39 Question Id : 8643512649 Question Type : MCQ Option Shuffling : Yes Is Question Mandatory : No

Correct Marks : 4 Wrong Marks : 1

Given below are two statements :

Statement I : Potassium permanganate on heating at 573 K forms potassium manganate.

Statement II : Both potassium permanganate and potassium manganate are tetrahedral and paramagnetic in nature.

In the light of the above statements, choose the most appropriate answer from the options given below :

Options :

8643517953. Both statement I and statement II are false

8643517954. Both statement I and statement II are true

8643517955. Statement I is true but statement II is false

8643517956. Statement I is false but statement II is true

Question Number : 39 Question Id : 8643512649 Question Type : MCQ Option Shuffling : Yes Is Question Mandatory : No

Correct Marks : 4 Wrong Marks : 1

खाली दोन विधाने दिलेली आहेत.

विधान I : पोटॅशियम परमॅग्नेट 573 K तापमानाला गरम केले असता पोटॅशियम मॅग्नेट तयार होते.

विधान II : दोन्ही पोटॅशियम परमॅग्नेट आणि पोटॅशियम मॅग्नेट हे चतुष्पृष्ठी आणि समचुंबकीय आहेत.
वरील विधानांना अनुसरून खालील पर्यायांमधून योग्य उत्तर निवडा.

Options :

8643517953. दोन्ही विधान I आणि विधान II खोटी आहेत.

8643517954. दोन्ही विधान I आणि विधान II खरी आहेत.

8643517955. विधान I खरे आणि विधान II खोटे आहे.

8643517956. विधान I खोटे आणि विधान II खरे आहे.

Question Number : 40 Question Id : 8643512650 Question Type : MCQ Option Shuffling : Yes Is Question Mandatory : No

Correct Marks : 4 Wrong Marks : 1

Reducing smog is a mixture of :

Options :

8643517957. Smoke, fog and O₃

8643517958. Smoke, fog and SO₂

8643517959. Smoke, fog and N₂O₃

8643517960. Smoke, fog and CH₂=CH-CHO

Question Number : 40 Question Id : 8643512650 Question Type : MCQ Option Shuffling : Yes Is Question Mandatory : No

Correct Marks : 4 Wrong Marks : 1

क्षपणकारक धूतर हा _____ मिश्रण आहे.

Options :

8643517957. धूर, धुके आणि O₃

8643517958. धूर, धुके आणि SO_2

8643517959. धूर, धुके आणि N_2O_3

8643517960. धूर, धुके आणि $\text{CH}_2=\text{CH}-\text{CHO}$

Question Number : 41 Question Id : 8643512651 Question Type : MCQ Option Shuffling : Yes Is Question Mandatory : No

Correct Marks : 4 Wrong Marks : 1

Given below are two statements :

Statement I : Retardation factor (R_f) can be measured in meter/centimeter.

Statement II : R_f value of a compound remains constant in all solvents.

Choose the most appropriate answer from the options given below :

Options :

8643517961. Both statement I and statement II are true

8643517962. Both statement I and statement II are false

8643517963. Statement I is true but statement II is false

8643517964. Statement I is false but statement II is true

Question Number : 41 Question Id : 8643512651 Question Type : MCQ Option Shuffling : Yes Is Question Mandatory : No

Correct Marks : 4 Wrong Marks : 1

खाली दोन विधाने दिलेली आहेत.

विधान I : मंदन गुणक (R_f) मीटर/सेंटीमीटर मध्ये मोजता येतो.

विधान II : संयुगासाठी R_f ची किंमत सर्व द्रावकात सारखीच असते.

वरील विधानांना अनुसरून खालील पर्यायांमधून योग्य उत्तर निवडा.

Options :

8643517961. दोन्ही विधान I आणि विधान II खरी आहेत.

8643517962. दोन्ही विधान I आणि विधान II खोटी आहेत.

8643517963. विधान I खरे आहे आणि विधान II खोटे आहे.

8643517964. विधान I खोटे आहे आणि विधान II खरे आहे.

Question Number : 42 Question Id : 8643512652 Question Type : MCQ Option Shuffling : Yes Is Question Mandatory : No

Correct Marks : 4 Wrong Marks : 1

Which of the following is an aromatic compound ?

Options :

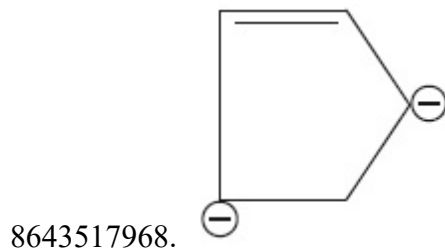
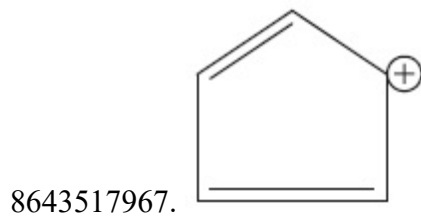
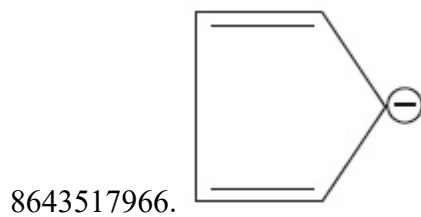
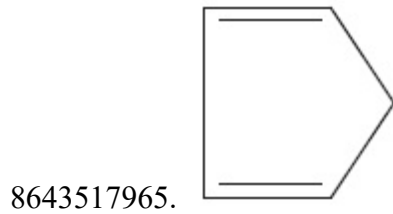

Question Number : 42 Question Id : 8643512652 Question Type : MCQ Option Shuffling : Yes Is Question Mandatory : No

Correct Marks : 4 Wrong Marks : 1

खालीलपैकी अॅरोमॅटिक संयुग कोणते आहे ?

Options :

8643517965.

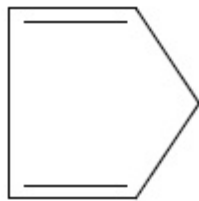

8643517966.

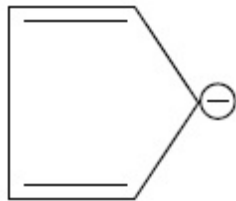

8643517967.

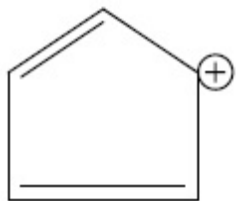

8643517968.

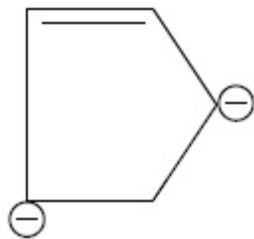

Question Number : 43 Question Id : 8643512653 Question Type : MCQ Option Shuffling : Yes Is Question Mandatory : No Correct Marks : 4 Wrong Marks : 1

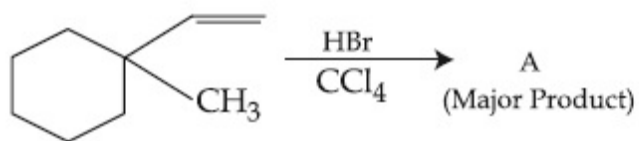

Product "A" in the above chemical reaction is :

Options :

8643517969.

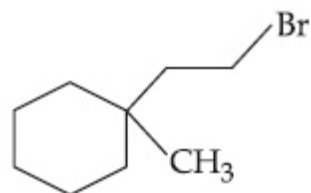

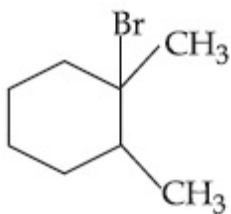

8643517970.

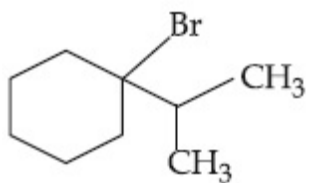

8643517971.

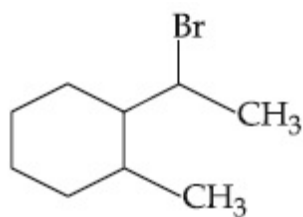

8643517972.

Question Number : 43 Question Id : 8643512653 Question Type : MCQ Option Shuffling : Yes Is Question Mandatory : No

Correct Marks : 4 Wrong Marks : 1

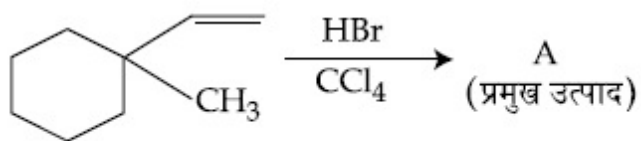

वरील रासायनिक अभिक्रियेतील उत्पाद "A" _____ आहे.

Options :

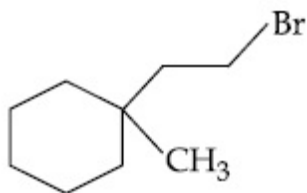

8643517969.

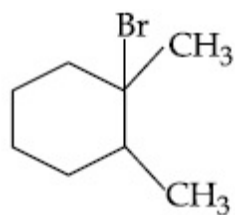

8643517970.

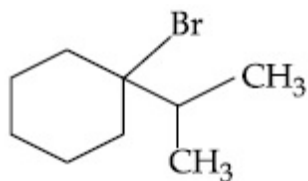

8643517971.

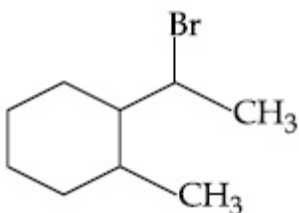

8643517972.

Question Number : 44 Question Id : 8643512654 Question Type : MCQ Option Shuffling : Yes Is Question Mandatory : No

Correct Marks : 4 Wrong Marks : 1



The above reaction requires which of the following reaction conditions ?

Options :

8643517973. 623 K, Cu, 300 atm

8643517974. 573 K, Cu, 300 atm

8643517975. 623 K, 300 atm

8643517976. 573 K, 300 atm

Question Number : 44 Question Id : 8643512654 Question Type : MCQ Option Shuffling : Yes Is Question Mandatory : No

Correct Marks : 4 Wrong Marks : 1

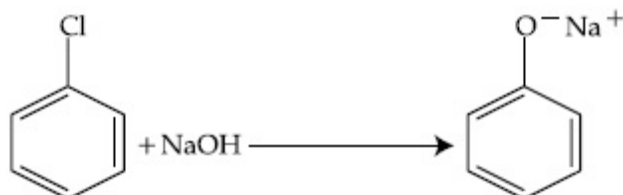

वरील अभिक्रियेसाठी खालीलपैकी कोणत्या क्रियेच्या परिस्थितीची गरज असते ?

Options :

8643517973. 623 K, Cu, 300 atm

8643517974. 573 K, Cu, 300 atm

8643517975. 623 K, 300 atm

8643517976. 573 K, 300 atm

Question Number : 45 Question Id : 8643512655 Question Type : MCQ Option Shuffling : Yes Is

Question Mandatory : No

Correct Marks : 4 Wrong Marks : 1

Mesityl oxide is a common name of :

Options :

8643517977. 4-Methyl pent-3-en-2-one

8643517978. 2,4-Dimethyl pentan-3-one

8643517979. 2-Methyl cyclohexanone

8643517980. 3-Methyl cyclohexane carbaldehyde

Question Number : 45 Question Id : 8643512655 Question Type : MCQ Option Shuffling : Yes Is

Question Mandatory : No

Correct Marks : 4 Wrong Marks : 1

मेसिटिल ऑक्साइड हे _____ चे सर्वसाधारण नाव आहे.

Options :

8643517977. 4-मिथाइल पेंट-3-इन-2-ओन

8643517978. 2,4-डायमिथाइल पेंटन-3-ओन

8643517979. 2-मिथाइल सायक्लोहेक्झानोन

8643517980. 3-मिथाइल सायक्लोहेक्झेन कार्बाल्डीहाइड

Question Number : 46 Question Id : 8643512656 Question Type : MCQ Option Shuffling : Yes Is

Question Mandatory : No

Correct Marks : 4 Wrong Marks : 1

Hoffmann bromamide degradation of benzamide gives product A, which upon heating with CHCl_3 and NaOH gives product B.

The structures of A and B are :

Options :

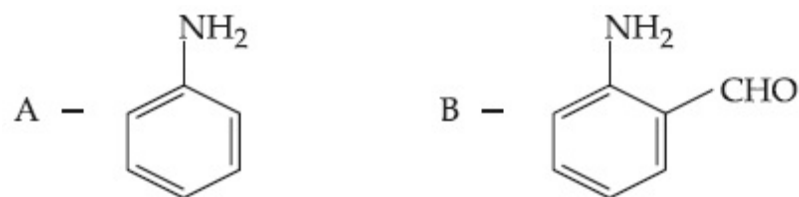
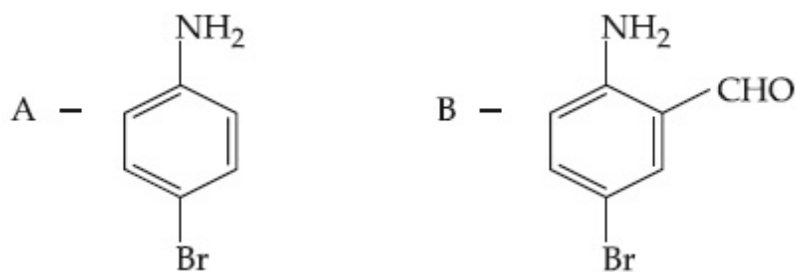
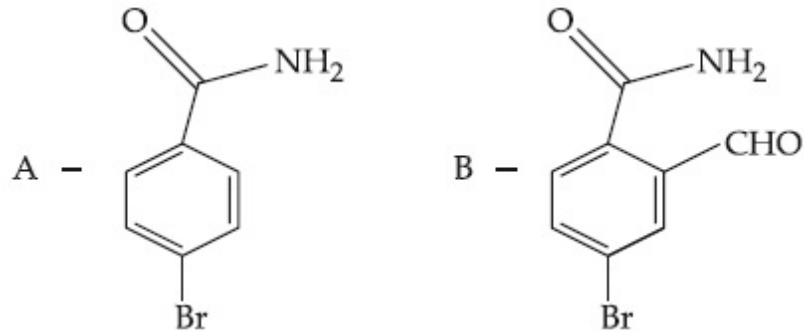

Question Number : 46 Question Id : 8643512656 Question Type : MCQ Option Shuffling : Yes Is Question Mandatory : No

Correct Marks : 4 Wrong Marks : 1

बेंझामाइडच्या हॉफमन ब्रोमामाइड विघटनाने उत्पाद A मिळतो, तो CHCl_3 आणि NaOH बरोबर तापविल्यास उत्पाद B देतो.

A आणि B च्या संरचना _____ आहेत.

Options :

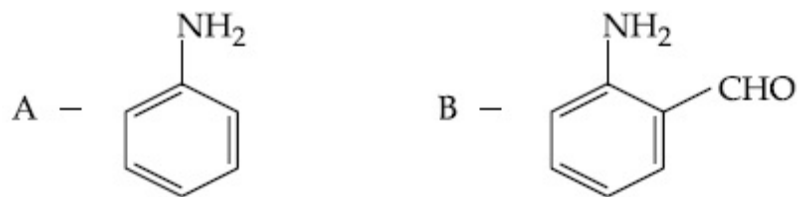
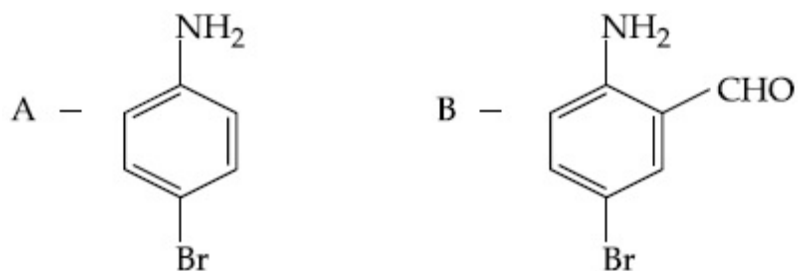
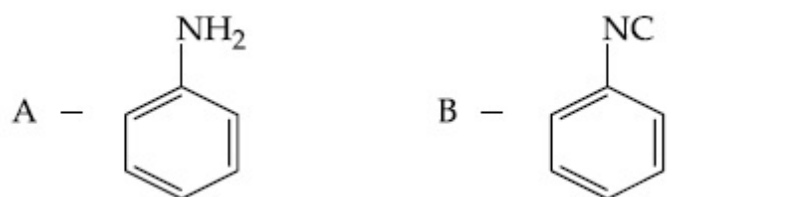
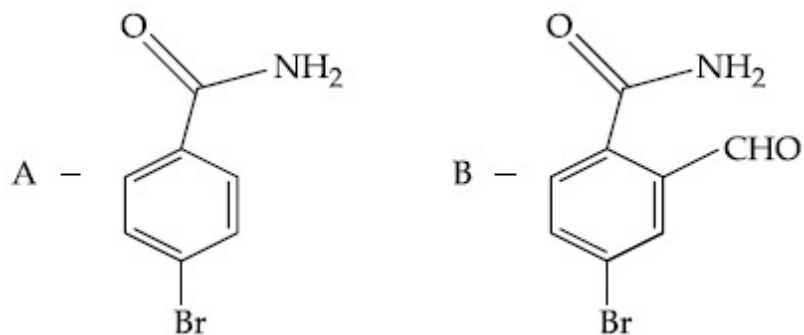

Question Number : 47 Question Id : 8643512657 Question Type : MCQ Option Shuffling : Yes Is Question Mandatory : No

Correct Marks : 4 Wrong Marks : 1

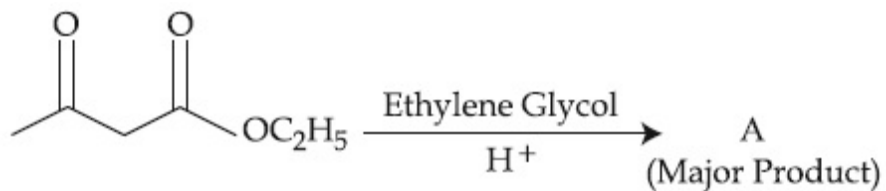

The product "A" in the above reaction is :

Options :

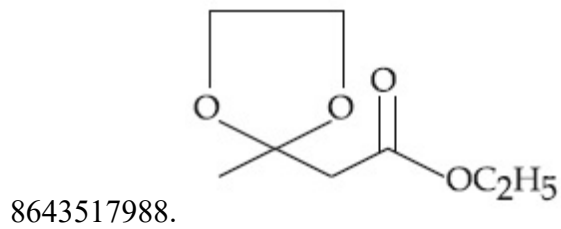
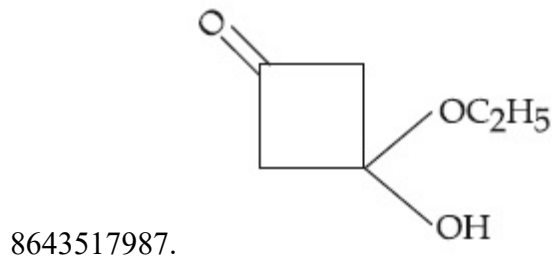
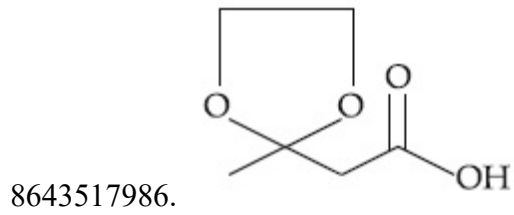
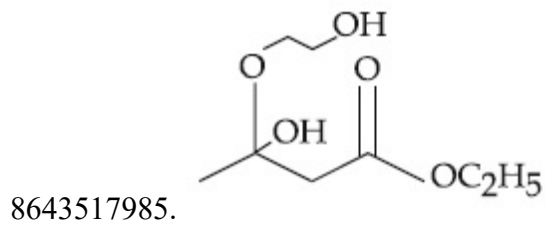

Question Number : 47 Question Id : 8643512657 Question Type : MCQ Option Shuffling : Yes Is
 Question Mandatory : No
 Correct Marks : 4 Wrong Marks : 1

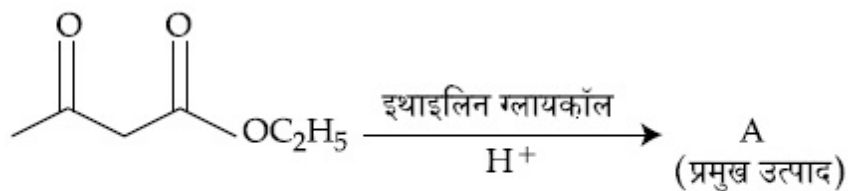

वरील अभिक्रियेतील उत्पाद "A" _____ आहे.

Options :

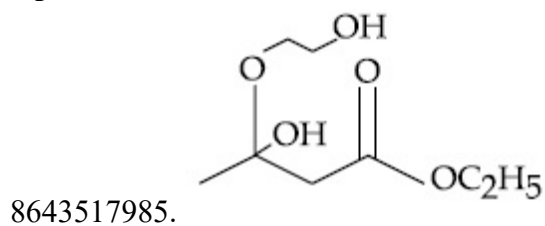

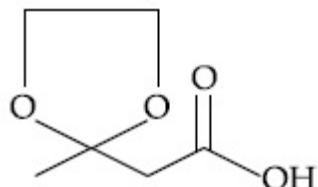

8643517986.

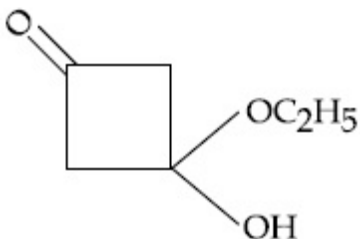

8643517987.

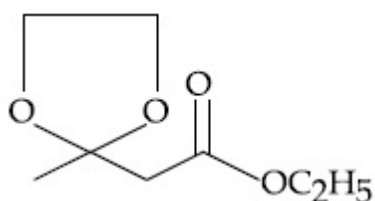

8643517988.

Question Number : 48 Question Id : 8643512658 Question Type : MCQ Option Shuffling : Yes Is Question Mandatory : No

Correct Marks : 4 Wrong Marks : 1

Which of the following reaction is an example of ammonolysis ?

Options :

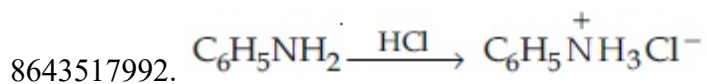
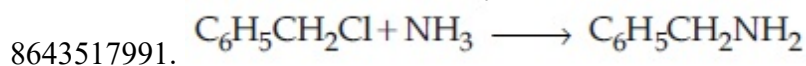
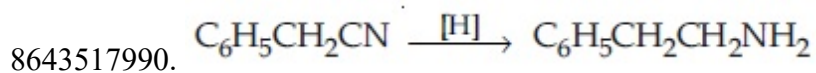
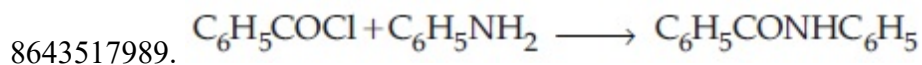

Question Number : 48 Question Id : 8643512658 Question Type : MCQ Option Shuffling : Yes Is Question Mandatory : No

Correct Marks : 4 Wrong Marks : 1

खालीलपैकी कोणती अभिक्रिया ही अमोनोलाइसिसचे उदाहरण आहे ?

Options :

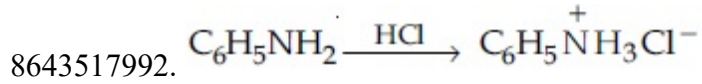
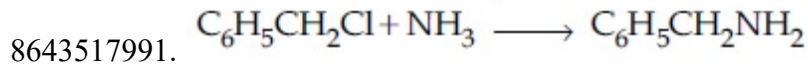
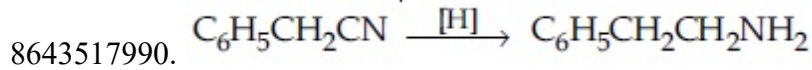
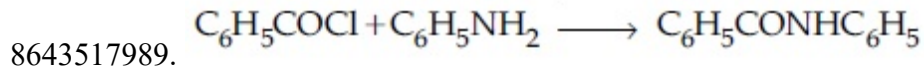

Question Number : 49 Question Id : 8643512659 Question Type : MCQ Option Shuffling : Yes Is Question Mandatory : No

Correct Marks : 4 Wrong Marks : 1

With respect to drug-enzyme interaction, identify the wrong statement.

Options :

8643517993. Competitive inhibitor binds to the enzyme's active site

8643517994. Allosteric inhibitor changes the enzyme's active site

8643517995. Allosteric inhibitor competes with the enzyme's active site

8643517996. Non-Competitive inhibitor binds to the allosteric site

Question Number : 49 Question Id : 8643512659 Question Type : MCQ Option Shuffling : Yes Is Question Mandatory : No

Correct Marks : 4 Wrong Marks : 1

औषध-विकर अन्वोन्यक्रियेसंदर्भातील चुकीचे विधान निवडा.

Options :

8643517993. स्पर्धात्मक संदमक विकराच्या क्रियाशील स्थानाला बद्ध होतो.

8643517994. अॅलोस्टेरी संदमक विकराच्या क्रियाशील स्थानाला बदलतो.

8643517995. अॅलोस्टेरी संदमक विकराच्या क्रियाशील स्थानाबरोबर स्पर्धा करतो.

8643517996. अस्पर्धात्मक संदमक अॅलोस्टेरी स्थानाशी बद्ध होतो.

Question Number : 50 Question Id : 8643512660 Question Type : MCQ Option Shuffling : Yes Is Question Mandatory : No

Correct Marks : 4 Wrong Marks : 1

Which of the following is correct structure of tyrosine ?

Options :

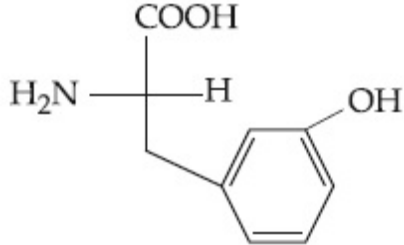

8643517997.

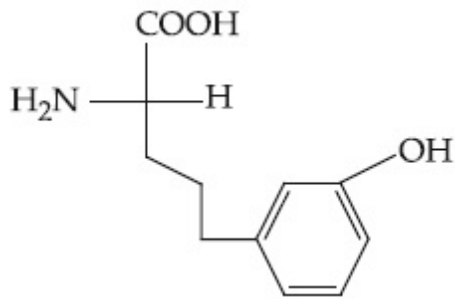

8643517998.

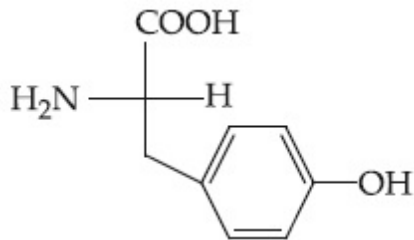

8643517999.

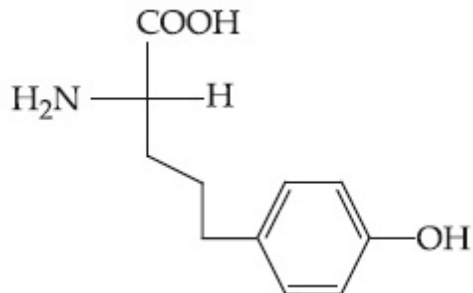

8643518000.

Question Number : 50 Question Id : 8643512660 Question Type : MCQ Option Shuffling : Yes Is Question Mandatory : No

Correct Marks : 4 Wrong Marks : 1

खालीलपैकी टायरोसिनची बरोबर संरचना कोणती आहे ?

Options :

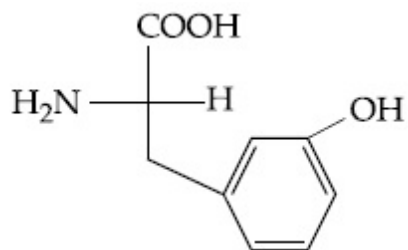

8643517997.

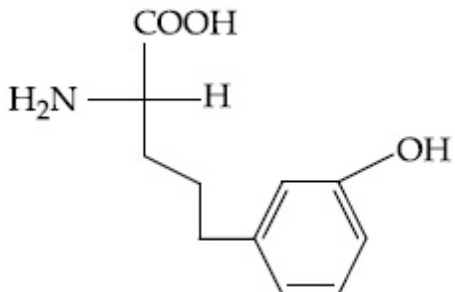

8643517998.

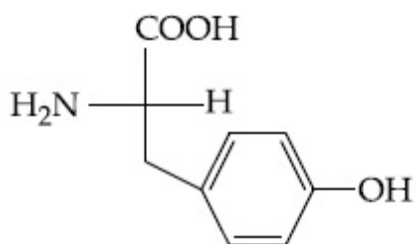

8643517999.

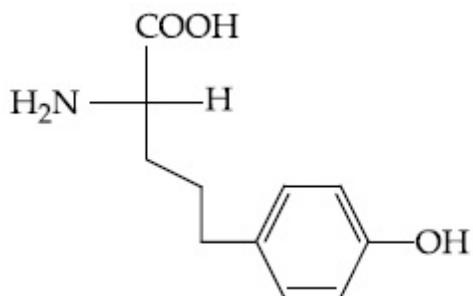

8643518000.

Chemistry Section B

Section Id :	864351178
Section Number :	4
Section type :	Online
Mandatory or Optional :	Mandatory
Number of Questions :	10
Number of Questions to be attempted :	5
Section Marks :	20
Mark As Answered Required? :	Yes
Sub-Section Number :	1
Sub-Section Id :	864351178

Question Shuffling Allowed :

Yes

Question Number : 51 Question Id : 8643512661 Question Type : SA

Correct Marks : 4 Wrong Marks : 0

The mole fraction of a solute in a 100 molal aqueous solution is _____ $\times 10^{-2}$.

(Round off to the Nearest Integer).

[Given : Atomic masses : H : 1.0 u, O : 16.0 u]

Response Type : Numeric

Evaluation Required For SA : Yes

Show Word Count : Yes

Answers Type : Equal

Text Areas : PlainText

Possible Answers :

100

Question Number : 51 Question Id : 8643512661 Question Type : SA

Correct Marks : 4 Wrong Marks : 0

100 मोलल जलीय द्रावणातील एका द्राव्याचा ग्रॅमरेणू अंश _____ $\times 10^{-2}$ आहे. (जवळच्या पूर्णांकात)

[दिलेले आहे : अणू वस्तुमान : H : 1.0 u, O : 16.0 u]

Response Type : Numeric

Evaluation Required For SA : Yes

Show Word Count : Yes

Answers Type : Equal

Text Areas : PlainText

Possible Answers :

100

Question Number : 52 Question Id : 8643512662 Question Type : SA

Correct Marks : 4 Wrong Marks : 0

The pressure exerted by a non-reactive gaseous mixture of 6.4 g of methane and 8.8 g of carbon dioxide in a 10 L vessel at 27°C is _____ kPa.

(Round off to the Nearest Integer).

[Assume gases are ideal, $R = 8.314 \text{ J mol}^{-1} \text{ K}^{-1}$

Atomic masses : C : 12.0 u, H : 1.0 u, O : 16.0 u]

Response Type : Numeric

Evaluation Required For SA : Yes

Show Word Count : Yes

Answers Type : Equal

Text Areas : PlainText

Possible Answers :

100

Question Number : 52 Question Id : 8643512662 Question Type : SA

Correct Marks : 4 Wrong Marks : 0

6.4 g मिथेन आणि 8.8 g कार्बन डायऑक्साइडच्या अक्रियाशील वायू मिश्रणाने 10 L आकारमानाच्या भांड्यात 27°C ला _____ kPa दाब दिला. (जवळच्या पूर्णांकात)

[आदर्श वायू आहेत असे समजा, $R = 8.314 \text{ J mol}^{-1} \text{ K}^{-1}$

अणू वस्तुमान : C : 12.0 u, H : 1.0 u, O : 16.0 u]

Response Type : Numeric

Evaluation Required For SA : Yes

Show Word Count : Yes

Answers Type : Equal

Text Areas : PlainText

Possible Answers :

100

Question Number : 53 Question Id : 8643512663 Question Type : SA

Correct Marks : 4 Wrong Marks : 0

A certain orbital has $n = 4$ and $m_l = -3$. The number of radial nodes in this orbital is _____. (Round off to the Nearest Integer).

Response Type : Numeric

Evaluation Required For SA : Yes

Show Word Count : Yes

Answers Type : Equal

Text Areas : PlainText

Possible Answers :

100

Question Number : 53 Question Id : 8643512663 Question Type : SA

Correct Marks : 4 Wrong Marks : 0

एका कक्षिकेसाठी $n = 4$ आणि $m_l = -3$. ह्या कक्षिकेसाठी अरीय नोडची संख्या _____ आहे. (जवळच्या पूर्णांकात)

Response Type : Numeric

Evaluation Required For SA : Yes

Show Word Count : Yes

Answers Type : Equal

Text Areas : PlainText

Possible Answers :

100

Question Number : 54 Question Id : 8643512664 Question Type : SA

Correct Marks : 4 Wrong Marks : 0

The standard enthalpies of formation of Al_2O_3 and CaO are $-1675 \text{ kJ mol}^{-1}$ and -635 kJ mol^{-1} respectively.

For the reaction

$3\text{CaO} + 2\text{Al} \rightarrow 3\text{Ca} + \text{Al}_2\text{O}_3$ the standard reaction enthalpy $\Delta_r H^0 = \text{_____ kJ}$.

(Round off to the Nearest Integer).

Response Type : Numeric

Evaluation Required For SA : Yes

Show Word Count : Yes

Answers Type : Equal

Text Areas : PlainText

Possible Answers :

100

Question Number : 54 Question Id : 8643512664 Question Type : SA

Correct Marks : 4 Wrong Marks : 0

Al_2O_3 आणि CaO ह्यांच्या घडणाच्या मानक एन्थॅल्पी अनुक्रमे $-1675 \text{ kJ mol}^{-1}$ आणि -635 kJ mol^{-1} आहेत.

अभिक्रियेसाठी

$3\text{CaO} + 2\text{Al} \rightarrow 3\text{Ca} + \text{Al}_2\text{O}_3$, मानक अभिक्रिया एन्थॅल्पी $\Delta_r H^0 = \text{_____ kJ}$ आहे. (जवळच्या पूर्णांकात)

Response Type : Numeric

Evaluation Required For SA : Yes

Show Word Count : Yes

Answers Type : Equal

Text Areas : PlainText

Possible Answers :

100

Question Number : 55 Question Id : 8643512665 Question Type : SA

Correct Marks : 4 Wrong Marks : 0

The oxygen dissolved in water exerts a partial pressure of 20 kPa in the vapour above water.

The molar solubility of oxygen in water is $\text{_____} \times 10^{-5} \text{ mol dm}^{-3}$.

(Round off to the Nearest Integer).

[Given : Henry's law constant = $K_H = 8.0 \times 10^4 \text{ kPa}$ for O_2 .

Density of water with dissolved oxygen = 1.0 kg dm^{-3}]

Response Type : Numeric

Evaluation Required For SA : Yes

Show Word Count : Yes

Answers Type : Equal

Text Areas : PlainText

Possible Answers :

100

Question Number : 55 Question Id : 8643512665 Question Type : SA

Correct Marks : 4 Wrong Marks : 0

पाण्यात विरघळलेल्या ऑक्सिजनचा पाण्यावरील वाफेत 20 kPa एवढा आंशिक दाब आहे. ऑक्सिजनची पाण्यातील ग्रॅमरेणू द्रावणीयता $\times 10^{-5} \text{ mol dm}^{-3}$ आहे. (जवळच्या पूर्णांकात)

[दिलेले आहे : हेन्रीच्या नियमाचा स्थिरांक $= K_H = 8.0 \times 10^4 \text{ kPa O}_2$ साठी

विरघळलेल्या ऑक्सिजन सोबत पाण्याची घनता $= 1.0 \text{ kg dm}^{-3}$]

Response Type : Numeric

Evaluation Required For SA : Yes

Show Word Count : Yes

Answers Type : Equal

Text Areas : PlainText

Possible Answers :

100

Question Number : 56 Question Id : 8643512666 Question Type : SA

Correct Marks : 4 Wrong Marks : 0

0.01 moles of a weak acid HA ($K_a = 2.0 \times 10^{-6}$) is dissolved in 1.0 L of 0.1 M HCl solution.

The degree of dissociation of HA is $\times 10^{-5}$ (Round off to the Nearest Integer).

[Neglect volume change on adding HA.

Assume degree of dissociation $\ll 1$]

Response Type : Numeric

Evaluation Required For SA : Yes

Show Word Count : Yes

Answers Type : Equal

Text Areas : PlainText

Possible Answers :

100

Question Number : 56 Question Id : 8643512666 Question Type : SA

Correct Marks : 4 Wrong Marks : 0

0.01 मोल एक क्षीण आम्ल HA ($K_a = 2.0 \times 10^{-6}$) हे 1.0 L, 0.1 M HCl च्या द्रावणात विरघळवले. HA चा विचरणांश _____ $\times 10^{-5}$ आहे. (जवळच्या पूर्णांकात)

[HA मिसळल्याने आकारमानातील बदल सोडून द्या.

समजा विचरणांश $\ll 1$]

Response Type : Numeric

Evaluation Required For SA : Yes

Show Word Count : Yes

Answers Type : Equal

Text Areas : PlainText

Possible Answers :

100

Question Number : 57 **Question Id :** 8643512667 **Question Type :** SA

Correct Marks : 4 **Wrong Marks :** 0

15 mL of aqueous solution of Fe^{2+} in acidic medium completely reacted with 20 mL of 0.03 M aqueous $Cr_2O_7^{2-}$. The molarity of the Fe^{2+} solution is _____ $\times 10^{-2}$ M. (Round off to the Nearest Integer).

Response Type : Numeric

Evaluation Required For SA : Yes

Show Word Count : Yes

Answers Type : Equal

Text Areas : PlainText

Possible Answers :

100

Question Number : 57 **Question Id :** 8643512667 **Question Type :** SA

Correct Marks : 4 **Wrong Marks :** 0

आम्ल माध्यमात 15 mL Fe^{2+} च्या जलीय द्रावणाची संपूर्ण क्रिया होण्यासाठी 20 mL 0.03 M जलीय $Cr_2O_7^{2-}$ लागले. Fe^{2+} द्रावणाची ग्रॅमरेणुता _____ $\times 10^{-2}$ M आहे. (जवळच्या पूर्णांकात)

Response Type : Numeric

Evaluation Required For SA : Yes

Show Word Count : Yes

Answers Type : Equal

Text Areas : PlainText

Possible Answers :

100

Question Number : 58 Question Id : 8643512668 Question Type : SA

Correct Marks : 4 Wrong Marks : 0

For a certain first order reaction 32% of the reactant is left after 570 s. The rate constant of this reaction is _____ $\times 10^{-3} \text{ s}^{-1}$. (Round off to the Nearest Integer).

[Given : $\log_{10}2 = 0.301$, $\ln 10 = 2.303$]

Response Type : Numeric

Evaluation Required For SA : Yes

Show Word Count : Yes

Answers Type : Equal

Text Areas : PlainText

Possible Answers :

100

Question Number : 58 Question Id : 8643512668 Question Type : SA

Correct Marks : 4 Wrong Marks : 0

एका प्रथम कोटीच्या क्रियेसाठी 32% अभिक्रियण 570 s नंतर शिल्लक राहिला. ह्या क्रियेसाठी गती स्थिरांक _____ $\times 10^{-3} \text{ s}^{-1}$ आहे. (जवळच्या पूर्णांकात)

[दिलेले आहे : $\log_{10}2 = 0.301$, $\ln 10 = 2.303$]

Response Type : Numeric

Evaluation Required For SA : Yes

Show Word Count : Yes

Answers Type : Equal

Text Areas : PlainText

Possible Answers :

100

Question Number : 59 Question Id : 8643512669 Question Type : SA

Correct Marks : 4 Wrong Marks : 0

The reaction of white phosphorus on boiling with alkali in inert atmosphere resulted in the formation of product 'A'. The reaction of 1 mol of 'A' with excess of AgNO_3 in aqueous medium gives _____ mol(s) of Ag. (Round off to the Nearest Integer).

Response Type : Numeric

Evaluation Required For SA : Yes

Show Word Count : Yes

Answers Type : Equal

Text Areas : PlainText

Possible Answers :

100

Question Number : 59 Question Id : 8643512669 Question Type : SA

Correct Marks : 4 Wrong Marks : 0

पांढऱ्या फॉस्फरसच्या अल्कलीसोबत उदासिन वातावरणात उकळव्याच्या अभिक्रियेतून उत्पाद 'A' तयार झाला. 1 mol 'A' च्या जास्त AgNO_3 च्या जलीय माध्यमातील अभिक्रियेतून _____ mol(s) Ag चे तयार होतात. (जवळच्या पूर्णांकात)

Response Type : Numeric

Evaluation Required For SA : Yes

Show Word Count : Yes

Answers Type : Equal

Text Areas : PlainText

Possible Answers :

100

Question Number : 60 Question Id : 8643512670 Question Type : SA

Correct Marks : 4 Wrong Marks : 0

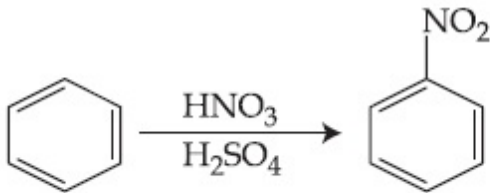

In the above reaction, 3.9 g of benzene on nitration gives 4.92 g of nitrobenzene. The percentage yield of nitrobenzene in the above reaction is _____%. (Round off to the Nearest Integer).

(Given atomic mass : C : 12.0 u, H : 1.0 u, O : 16.0 u, N : 14.0 u)

Response Type : Numeric

Evaluation Required For SA : Yes

Show Word Count : Yes

Answers Type : Equal

Text Areas : PlainText

Possible Answers :

100

Question Number : 60 Question Id : 8643512670 Question Type : SA

Correct Marks : 4 Wrong Marks : 0

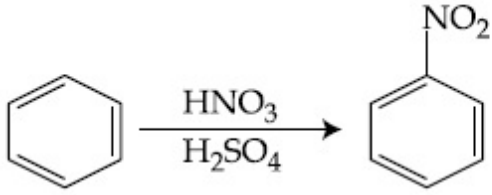

वरील अभिक्रियेत 3.9 ग्रॅ बेंझिन पासून 4.92 ग्रॅम नायट्रोबेंझिन मिळाले. वरील अभिक्रियेतील नायट्रोबेंझिनची शेकडा प्राप्ती _____% आहे. (जवळच्या पूर्णांकात)

[दिलेले आहे : अणू वस्तुमान : C : 12.0 u, H : 1.0 u, O : 16.0 u, N : 14.0 u]

Response Type : Numeric

Evaluation Required For SA : Yes

Show Word Count : Yes

Answers Type : Equal

Text Areas : PlainText

Possible Answers :

100

Mathematics Section A

Section Id :	864351179
Section Number :	5
Section type :	Online
Mandatory or Optional :	Mandatory
Number of Questions :	20
Number of Questions to be attempted :	20
Section Marks :	80
Mark As Answered Required? :	Yes
Sub-Section Number :	1
Sub-Section Id :	864351179
Question Shuffling Allowed :	Yes

Question Number : 61 **Question Id :** 8643512671 **Question Type :** MCQ **Option Shuffling :** Yes Is

Question Mandatory : No

Correct Marks : 4 **Wrong Marks :** 1

In a school, there are three types of games to be played. Some of the students play two types of games, but none play all the three games. Which Venn diagrams can justify the above statement ?

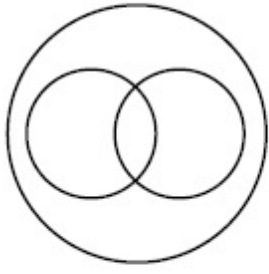

P

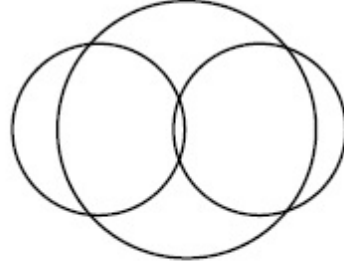

Q

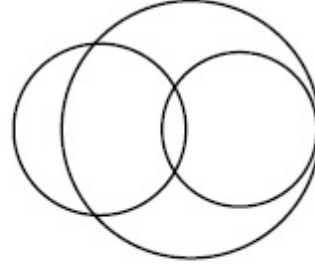

R

Options :

8643518011. P and Q

8643518012. P and R

8643518013. Q and R

8643518014. None of these

Question Number : 61 Question Id : 8643512671 Question Type : MCQ Option Shuffling : Yes Is Question Mandatory : No

Correct Marks : 4 Wrong Marks : 1

एका शाळे मध्ये, तीन प्रकारचे खेळ खेळले जातात. कांही विद्यार्थी दोन प्रकारचे खेळ खेळतात, परंतु सर्व तीन खेळ खेळत नाही. कोणती वेन आकृती (Venn diagram) वरील विधानांचे समर्थन करू शकते ?

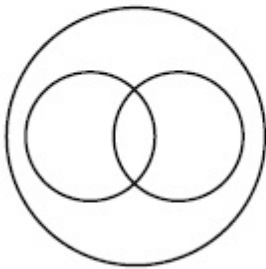

P

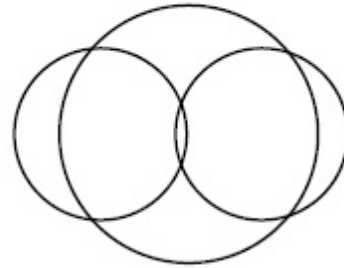

Q

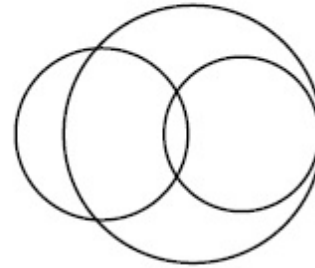

R

Options :

8643518011. P आणि Q

8643518012. P आणि R

8643518013. Q आणि R

8643518014. कोणतीही नाही

Question Number : 62 Question Id : 8643512672 Question Type : MCQ Option Shuffling : Yes Is Question Mandatory : No

Correct Marks : 4 Wrong Marks : 1

The area of the triangle with vertices $A(z)$, $B(iz)$ and $C(z+iz)$ is :

Options :

8643518015. $\frac{1}{2} |z + iz|^2$

8643518016. $\frac{1}{2} |z|^2$

8643518017. $\frac{1}{2}$

8643518018. 1

Question Number : 62 Question Id : 8643512672 Question Type : MCQ Option Shuffling : Yes Is Question Mandatory : No

Correct Marks : 4 Wrong Marks : 1

$A(z)$, $B(iz)$ आणि $C(z+iz)$ शिरोबिंदू असणाऱ्या त्रिकोणाचे क्षेत्रफळ _____ आहे.

Options :

8643518015. $\frac{1}{2} |z + iz|^2$

8643518016. $\frac{1}{2} |z|^2$

8643518017. $\frac{1}{2}$

8643518018. 1

Question Number : 63 Question Id : 8643512673 Question Type : MCQ Option Shuffling : Yes Is Question Mandatory : No

Correct Marks : 4 Wrong Marks : 1

If $A = \begin{pmatrix} 0 & \sin\alpha \\ \sin\alpha & 0 \end{pmatrix}$ and $\det\left(A^2 - \frac{1}{2}I\right) = 0$, then a possible value of α is :

Options :

8643518019. $\frac{\pi}{4}$

8643518020. $\frac{\pi}{3}$

8643518021. $\frac{\pi}{6}$

8643518022. $\frac{\pi}{2}$

Question Number : 63 Question Id : 8643512673 Question Type : MCQ Option Shuffling : Yes Is Question Mandatory : No

Correct Marks : 4 Wrong Marks : 1

जर $A = \begin{pmatrix} 0 & \sin\alpha \\ \sin\alpha & 0 \end{pmatrix}$ आणि $\det\left(A^2 - \frac{1}{2}I\right) = 0$ आहे, तर α चे शक्य मूल्य (possible value) _____ आहे.

Options :

8643518019. $\frac{\pi}{4}$

8643518020. $\frac{\pi}{3}$

8643518021. $\frac{\pi}{6}$

8643518022. $\frac{\pi}{2}$

Question Number : 64 Question Id : 8643512674 Question Type : MCQ Option Shuffling : Yes Is Question Mandatory : No

Correct Marks : 4 Wrong Marks : 1

The system of equations $kx + y + z = 1$, $x + ky + z = k$ and $x + y + zk = k^2$ has no solution if k is equal to :

Options :

8643518023. 0

8643518024. 1

8643518025. -1

8643518026. -2

Question Number : 64 Question Id : 8643512674 Question Type : MCQ Option Shuffling : Yes Is Question Mandatory : No

Correct Marks : 4 Wrong Marks : 1

$kx + y + z = 1$, $x + ky + z = k$ आणि $x + y + zk = k^2$ या समीकरणांची उकल नसलेली (no solution) प्रणाली आहे, जर k बरोबर _____ आहे.

Options :

8643518023. 0

8643518024. 1

8643518025. -1

8643518026. -2

Question Number : 65 Question Id : 8643512675 Question Type : MCQ Option Shuffling : Yes Is Question Mandatory : No

Correct Marks : 4 Wrong Marks : 1

Team 'A' consists of 7 boys and n girls and Team 'B' has 4 boys and 6 girls. If a total of 52 single matches can be arranged between these two teams when a boy plays against a boy and a girl plays against a girl, then n is equal to :

Options :

8643518027. 2

8643518028. 4

8643518029. 5

8643518030. 6

Question Number : 65 Question Id : 8643512675 Question Type : MCQ Option Shuffling : Yes Is**Question Mandatory : No****Correct Marks : 4 Wrong Marks : 1**

'A' संघामध्ये 7 मुले आणि n मुली आहेत आणि 'B' संघामध्ये 4 मुले आणि 6 मुली आहेत. जर या दोन संघांमध्ये एकूण 52 एकेरी स्पर्धेचे (single matches) आयोजन केले आहे की जेव्हा एक मुलगा, एका मुलाच्या विरुद्ध खेळेल आणि एक मुलगी, एका मुलीच्या विरुद्ध खेळेल, तर n बरोबर _____ आहे.

Options :

8643518027. 2

8643518028. 4

8643518029. 5

8643518030. 6

Question Number : 66 Question Id : 8643512676 Question Type : MCQ Option Shuffling : Yes Is**Question Mandatory : No****Correct Marks : 4 Wrong Marks : 1**

If the fourth term in the expansion of $(x + x^{\log_2 x})^7$ is 4480, then the value of x where $x \in \mathbf{N}$ is equal to :

Options :

8643518031. 1

8643518032. 2

8643518033. 3

8643518034. 4

Question Number : 66 Question Id : 8643512676 Question Type : MCQ Option Shuffling : Yes Is Question Mandatory : No

Correct Marks : 4 Wrong Marks : 1

$(x + x^{\log_2 x})^7$ या विस्तारातील चौथे पद (fourth term) 4480 आहे, तर x चे मूल्य बरोबर _____ आहे, जेव्हा $x \in \mathbb{N}$.

Options :

8643518031. 1

8643518032. 2

8643518033. 3

8643518034. 4

Question Number : 67 Question Id : 8643512677 Question Type : MCQ Option Shuffling : Yes Is Question Mandatory : No

Correct Marks : 4 Wrong Marks : 1

The value of $4 + \frac{1}{5 + \frac{1}{4 + \frac{1}{5 + \frac{1}{4 + \dots \infty}}}}$ is :

Options :

8643518035. $2 + \frac{2}{5}\sqrt{30}$ 8643518036. $2 + \frac{4}{\sqrt{5}}\sqrt{30}$ 8643518037. $5 + \frac{2}{5}\sqrt{30}$ 8643518038. $4 + \frac{4}{\sqrt{5}}\sqrt{30}$

Question Number : 67 Question Id : 8643512677 Question Type : MCQ Option Shuffling : Yes Is Question Mandatory : No Correct Marks : 4 Wrong Marks : 1

$$4 + \frac{1}{5 + \frac{1}{4 + \frac{1}{5 + \frac{1}{4 + \dots \infty}}}} \text{ चे मूल्य } \underline{\hspace{2cm}} \text{ आहे.}$$

Options :

8643518035. $2 + \frac{2}{5}\sqrt{30}$

8643518036. $2 + \frac{4}{\sqrt{5}}\sqrt{30}$

8643518037. $5 + \frac{2}{5}\sqrt{30}$

8643518038. $4 + \frac{4}{\sqrt{5}}\sqrt{30}$

Question Number : 68 Question Id : 8643512678 Question Type : MCQ Option Shuffling : Yes Is Question Mandatory : No Correct Marks : 4 Wrong Marks : 1

If $\cot^{-1}(\alpha) = \cot^{-1}2 + \cot^{-1}8 + \cot^{-1}18 + \cot^{-1}32 + \dots$ upto 100 terms, then α is :

Options :

8643518039. 1.00

8643518040. 1.01

8643518041. 1.02

8643518042. 1.03

Question Number : 68 Question Id : 8643512678 Question Type : MCQ Option Shuffling : Yes Is Question Mandatory : No

Correct Marks : 4 Wrong Marks : 1

जर $\cot^{-1}(\alpha) = \cot^{-1}2 + \cot^{-1}8 + \cot^{-1}18 + \cot^{-1}32 + \dots$ 100 पदांपर्यंत, तर α _____ आहे.

Options :

8643518039. 1.00

8643518040. 1.01

8643518041. 1.02

8643518042. 1.03

Question Number : 69 Question Id : 8643512679 Question Type : MCQ Option Shuffling : Yes Is Question Mandatory : No

Correct Marks : 4 Wrong Marks : 1

The inverse of $y = 5^{\log x}$ is :

Options :

8643518043. $x = 5^{\frac{1}{\log y}}$

8643518044. $x = y^{\frac{1}{\log 5}}$

8643518045. $x = 5^{\log y}$

8643518046. $x = y^{\log 5}$

Question Number : 69 Question Id : 8643512679 Question Type : MCQ Option Shuffling : Yes Is Question Mandatory : No

Correct Marks : 4 Wrong Marks : 1

$y = 5^{\log x}$ चा व्यस्त (inverse) _____ आहे.

Options :

8643518043. $x = 5^{\frac{1}{\log y}}$

$$8643518044. \quad x = y^{\frac{1}{\log 5}}$$

$$8643518045. \quad x = 5^{\log y}$$

$$8643518046. \quad x = y^{\log 5}$$

Question Number : 70 Question Id : 8643512680 Question Type : MCQ Option Shuffling : Yes Is Question Mandatory : No

Correct Marks : 4 Wrong Marks : 1

The value of $\lim_{x \rightarrow 0^+} \frac{\cos^{-1}(x - [x]^2) \cdot \sin^{-1}(x - [x]^2)}{x - x^3}$, where $[x]$ denotes the greatest integer $\leq x$ is :

Options :

$$8643518047. \quad \frac{\pi}{4}$$

$$8643518048. \quad 0$$

$$8643518049. \quad \frac{\pi}{2}$$

$$8643518050. \quad \pi$$

Question Number : 70 Question Id : 8643512680 Question Type : MCQ Option Shuffling : Yes Is Question Mandatory : No

Correct Marks : 4 Wrong Marks : 1

$\lim_{x \rightarrow 0^+} \frac{\cos^{-1}(x - [x]^2) \cdot \sin^{-1}(x - [x]^2)}{x - x^3}$ चे मूल्य _____ आहे, जेव्हा $[x]$ हे x किंवा x पेक्षा लहान

असणारे महत्तम पूर्णांक (greatest integer) दर्शविते.

Options :

$$8643518047. \quad \frac{\pi}{4}$$

8643518048. 0

8643518049. $\frac{\pi}{2}$

8643518050. π

Question Number : 71 Question Id : 8643512681 Question Type : MCQ Option Shuffling : Yes Is Question Mandatory : No

Correct Marks : 4 Wrong Marks : 1

Which of the following statements is incorrect for the function $g(\alpha)$ for $\alpha \in \mathbb{R}$ such that

$$g(\alpha) = \int_{\frac{\pi}{6}}^{\frac{\pi}{3}} \frac{\sin^\alpha x}{\cos^\alpha x + \sin^\alpha x} dx$$

Options :

8643518051. $g(\alpha)$ is a strictly increasing function

8643518052. $g(\alpha)$ is a strictly decreasing function

8643518053. $g(\alpha)$ has an inflection point at $\alpha = -\frac{1}{2}$

8643518054. $g(\alpha)$ is an even function

Question Number : 71 Question Id : 8643512681 Question Type : MCQ Option Shuffling : Yes Is Question Mandatory : No

Correct Marks : 4 Wrong Marks : 1

$\alpha \in \mathbb{R}$ साठी $g(\alpha)$ या फला साठी खालीलपैकी कोणते विधान असत्य आहे, जसे की

$$g(\alpha) = \int_{\frac{\pi}{6}}^{\frac{\pi}{3}} \frac{\sin^\alpha x}{\cos^\alpha x + \sin^\alpha x} dx ?$$

Options :

8643518051. $g(\alpha)$ हे काटेकोर पणे वाढते फल आहे.

8643518052. $g(\alpha)$ हे काटेकोर पणे घटते (decreasing) फल आहे.

8643518053. $g(\alpha)$ चा $\alpha = -\frac{1}{2}$ शी नतिपरिवर्तन (inflection) बिंदू आहे.

8643518054. $g(\alpha)$ हे एक सम फल आहे.

Question Number : 72 Question Id : 8643512682 Question Type : MCQ Option Shuffling : Yes Is Question Mandatory : No

Correct Marks : 4 Wrong Marks : 1

Which of the following is true for $y(x)$ that satisfies the differential equation

$$\frac{dy}{dx} = xy - 1 + x - y; y(0) = 0 :$$

Options :

8643518055. $y(1) = e^{-\frac{1}{2}} - 1$

8643518056. $y(1) = e^{\frac{1}{2}} - 1$

8643518057. $y(1) = e^{\frac{1}{2}} - e^{-\frac{1}{2}}$

8643518058. $y(1) = 1$

Question Number : 72 Question Id : 8643512682 Question Type : MCQ Option Shuffling : Yes Is Question Mandatory : No

Correct Marks : 4 Wrong Marks : 1

जे $\frac{dy}{dx} = xy - 1 + x - y; y(0) = 0$ या विकलक समीकरणाचे समाधान करणारे $y(x)$ साठी खालीलपैकी

कोणते सत्य (true) आहे ?

Options :

8643518055. $y(1) = e^{-\frac{1}{2}} - 1$

8643518056. $y(1) = e^{\frac{1}{2}} - 1$

8643518057. $y(1) = e^{\frac{1}{2}} - e^{-\frac{1}{2}}$

8643518058. $y(1) = 1$

Question Number : 73 Question Id : 8643512683 Question Type : MCQ Option Shuffling : Yes Is

Question Mandatory : No

Correct Marks : 4 Wrong Marks : 1

In a triangle PQR, the co-ordinates of the points P and Q are $(-2, 4)$ and $(4, -2)$ respectively. If the equation of the perpendicular bisector of PR is $2x - y + 2 = 0$, then the centre of the circumcircle of the ΔPQR is :

Options :

8643518059. $(1, 4)$

8643518060. $(0, 2)$

8643518061. $(-1, 0)$

8643518062. $(-2, -2)$

Question Number : 73 Question Id : 8643512683 Question Type : MCQ Option Shuffling : Yes Is

Question Mandatory : No

Correct Marks : 4 Wrong Marks : 1

त्रिकोण PQR मध्ये, P आणि Q या बिंदूंचे निर्देशक (co-ordinates) अनुक्रमे $(-2, 4)$ आणि $(4, -2)$ आहेत. जर PR च्या लंब दुभाजका (perpendicular bisector) चे समीकरण $2x - y + 2 = 0$ आहे, तर ΔPQR च्या परिवर्तुळ (circumcircle)चा केंद्रबिंदू (centre) _____ आहे.

Options :

8643518059. $(1, 4)$

8643518060. $(0, 2)$

8643518061. $(-1, 0)$

8643518062. $(-2, -2)$

Question Number : 74 Question Id : 8643512684 Question Type : MCQ Option Shuffling : Yes Is Question Mandatory : No

Correct Marks : 4 Wrong Marks : 1

The line $2x - y + 1 = 0$ is a tangent to the circle at the point $(2, 5)$ and the centre of the circle lies on $x - 2y = 4$. Then, the radius of the circle is :

Options :

8643518063. $5\sqrt{3}$

8643518064. $5\sqrt{4}$

8643518065. $4\sqrt{5}$

8643518066. $3\sqrt{5}$

Question Number : 74 Question Id : 8643512684 Question Type : MCQ Option Shuffling : Yes Is Question Mandatory : No

Correct Marks : 4 Wrong Marks : 1

$2x - y + 1 = 0$ ही रेषा वर्तुळाच्या $(2, 5)$ या बिंदू वरील स्पर्शिका (tangent) आहे आणि वर्तुळाचा केंद्रबिंदू $x - 2y = 4$ या रेषेवर स्थित आहे. तर वर्तुळाची त्रिज्या _____ आहे.

Options :

8643518063. $5\sqrt{3}$

8643518064. $5\sqrt{4}$

8643518065. $4\sqrt{5}$

8643518066. $3\sqrt{5}$

Question Number : 75 Question Id : 8643512685 Question Type : MCQ Option Shuffling : Yes Is Question Mandatory : No

Correct Marks : 4 Wrong Marks : 1

Choose the incorrect statement about the two circles whose equations are given below :

$$x^2 + y^2 - 10x - 10y + 41 = 0 \text{ and}$$

$$x^2 + y^2 - 16x - 10y + 80 = 0$$

Options :

8643518067. Circles have two intersection points.

8643518068. Both circles pass through the centre of each other.

8643518069. Both circles' centres lie inside region of one another.

8643518070. Distance between two centres is the average of radii of both the circles.

Question Number : 75 Question Id : 8643512685 Question Type : MCQ Option Shuffling : Yes Is

Question Mandatory : No

Correct Marks : 4 Wrong Marks : 1

$$x^2 + y^2 - 10x - 10y + 41 = 0 \text{ आणि}$$

$x^2 + y^2 - 16x - 10y + 80 = 0$ ही दोन वर्तुळांची समीकरणे दिली आहेत. या दोन वर्तुळांबाबत बरोबर नसलेले (incorrect) विधान शोधा.

Options :

8643518067. वर्तुळांचे दोन छेद बिंदू आहेत.

8643518068. दोन्ही वर्तुळे एक मेकांच्या केंद्र बिंदूतून जातात.

8643518069. दोन्ही वर्तुळांचे केंद्रे एक दूसऱ्याच्या आंतर भागात आहेत.

8643518070. दोन्ही केंद्राच्या मधील अंतर दोन्ही वर्तुळांच्या त्रिज्यांची सरासरी आहे.

Question Number : 76 Question Id : 8643512686 Question Type : MCQ Option Shuffling : Yes Is

Question Mandatory : No

Correct Marks : 4 Wrong Marks : 1

The equation of the plane which contains the y -axis and passes through the point $(1, 2, 3)$ is :

Options :

8643518071. $3x + z = 6$

8643518072. $x + 3z = 10$

8643518073. $x + 3z = 0$

8643518074. $3x - z = 0$

Question Number : 76 Question Id : 8643512686 Question Type : MCQ Option Shuffling : Yes Is

Question Mandatory : No

Correct Marks : 4 Wrong Marks : 1

(1, 2, 3) या बिंदू मधून जाणारे आणि y -अक्षाला सामावून (contains) घेणाऱ्या प्रतलाचे समीकरण _____ आहे.

Options :

8643518071. $3x + z = 6$

8643518072. $x + 3z = 10$

8643518073. $x + 3z = 0$

8643518074. $3x - z = 0$

Question Number : 77 Question Id : 8643512687 Question Type : MCQ Option Shuffling : Yes Is

Question Mandatory : No

Correct Marks : 4 Wrong Marks : 1

If the Boolean expression $(p \Rightarrow q) \Leftrightarrow (q * (\sim p))$ is a tautology, then the Boolean expression $p * (\sim q)$ is equivalent to :

Options :

8643518075. $P \Rightarrow q$

8643518076. $P \Rightarrow \sim q$

8643518077. $q \Rightarrow P$

8643518078. $\sim q \Rightarrow P$

Question Number : 77 Question Id : 8643512687 Question Type : MCQ Option Shuffling : Yes Is Question Mandatory : No

Correct Marks : 4 Wrong Marks : 1

जर $(p \Rightarrow q) \Leftrightarrow (q * (\sim p))$ ही बूलीय पदावली (Boolean expression) अनुलाप (tautology) आहे, तर $p * (\sim q)$ ही बूलीय पदावली _____ शी सममूल्य (equivalent) आहे.

Options :

8643518075. $P \Rightarrow q$

8643518076. $P \Rightarrow \sim q$

8643518077. $q \Rightarrow P$

8643518078. $\sim q \Rightarrow P$

Question Number : 78 Question Id : 8643512688 Question Type : MCQ Option Shuffling : Yes Is Question Mandatory : No

Correct Marks : 4 Wrong Marks : 1

Let $\vec{a} = 2\hat{i} - 3\hat{j} + 4\hat{k}$ and $\vec{b} = 7\hat{i} + \hat{j} - 6\hat{k}$.

If $\vec{r} \times \vec{a} = \vec{r} \times \vec{b}$, $\vec{r} \cdot (\hat{i} + 2\hat{j} + \hat{k}) = -3$, then $\vec{r} \cdot (2\hat{i} - 3\hat{j} + \hat{k})$ is equal to :

Options :

8643518079. 8

8643518080. 10

8643518081. 12

8643518082. 13

Question Number : 78 Question Id : 8643512688 Question Type : MCQ Option Shuffling : Yes Is Question Mandatory : No

Correct Marks : 4 Wrong Marks : 1

समजा $\vec{a} = 2\hat{i} - 3\hat{j} + 4\hat{k}$ आणि $\vec{b} = 7\hat{i} + \hat{j} - 6\hat{k}$ जर $\vec{r} \times \vec{a} = \vec{r} \times \vec{b}$,

$\vec{r} \cdot (\hat{i} + 2\hat{j} + \hat{k}) = -3$, तर $\vec{r} \cdot (2\hat{i} - 3\hat{j} + \hat{k})$ बरोबर _____ आहे.

Options :

8643518079. 8

8643518080. 10

8643518081. 12

8643518082. 13

Question Number : 79 Question Id : 8643512689 Question Type : MCQ Option Shuffling : Yes Is Question Mandatory : No

Correct Marks : 4 Wrong Marks : 1

Two dices are rolled. If both dices have six faces numbered 1, 2, 3, 5, 7 and 11, then the probability that the sum of the numbers on the top faces is less than or equal to 8 is :

Options :

8643518083. $\frac{5}{12}$

8643518084. $\frac{4}{9}$

8643518085. $\frac{17}{36}$

8643518086. $\frac{1}{2}$

Question Number : 79 Question Id : 8643512689 Question Type : MCQ Option Shuffling : Yes Is Question Mandatory : No

Correct Marks : 4 Wrong Marks : 1

दोन फासे (dices) फिरवीले (rolled) आहेत. जर दोन्ही फास्यांना सहा बाजू (faces) आहेत आणि त्या सहा बाजूंना 1, 2, 3, 5, 7 आणि 11 या संख्या अंकित आहेत, तर त्या फास्याच्या वरील (top) बाजूस 8 किंवा 8 पेक्षा लहान येणाऱ्या संख्येच्या बेरजेची संभाव्यता (probability) _____ आहे.

Options :

8643518083. $\frac{5}{12}$

8643518084. $\frac{4}{9}$

8643518085. $\frac{17}{36}$

8643518086. $\frac{1}{2}$

Question Number : 80 Question Id : 8643512690 Question Type : MCQ Option Shuffling : Yes Is Question Mandatory : No

Correct Marks : 4 Wrong Marks : 1

The sum of possible values of x for $\tan^{-1}(x + 1) + \cot^{-1}\left(\frac{1}{x - 1}\right) = \tan^{-1}\left(\frac{8}{31}\right)$ is :

Options :

8643518087. $-\frac{33}{4}$

8643518088. $-\frac{32}{4}$

8643518089. $-\frac{31}{4}$

8643518090. $-\frac{30}{4}$

Question Number : 80 Question Id : 8643512690 Question Type : MCQ Option Shuffling : Yes Is Question Mandatory : No

Correct Marks : 4 Wrong Marks : 1

$\tan^{-1}(x+1) + \cot^{-1}\left(\frac{1}{x-1}\right) = \tan^{-1}\left(\frac{8}{31}\right)$ साठी x च्या शक्य मूल्यांची (possible values) बेरीज

_____ आहे.

Options :

8643518087. $-\frac{33}{4}$

8643518088. $-\frac{32}{4}$

8643518089. $-\frac{31}{4}$

8643518090. $-\frac{30}{4}$

Mathematics Section B

Section Id :	864351180
Section Number :	6
Section type :	Online
Mandatory or Optional :	Mandatory
Number of Questions :	10
Number of Questions to be attempted :	5
Section Marks :	20
Mark As Answered Required? :	Yes
Sub-Section Number :	1
Sub-Section Id :	864351180
Question Shuffling Allowed :	Yes

Question Number : 81 Question Id : 8643512691 Question Type : SA

Correct Marks : 4 Wrong Marks : 0

The maximum value of z in the following equation $z = 6xy + y^2$, where $3x + 4y \leq 100$ and $4x + 3y \leq 75$ for $x \geq 0$ and $y \geq 0$ is _____.

Response Type : Numeric

Evaluation Required For SA : Yes

Show Word Count : Yes

Answers Type : Equal

Text Areas : PlainText

Possible Answers :

100

Question Number : 81 Question Id : 8643512691 Question Type : SA

Correct Marks : 4 Wrong Marks : 0

$z = 6xy + y^2$ या समीकरणामध्ये z चे कमाल मूल्य (maximum value) _____ आहे, जेव्हा $3x + 4y \leq 100$ आणि $4x + 3y \leq 75$, $x \geq 0$ आणि $y \geq 0$ साठी.

Response Type : Numeric

Evaluation Required For SA : Yes

Show Word Count : Yes

Answers Type : Equal

Text Areas : PlainText

Possible Answers :

100

Question Number : 82 Question Id : 8643512692 Question Type : SA

Correct Marks : 4 Wrong Marks : 0

If $A = \begin{bmatrix} 2 & 3 \\ 0 & -1 \end{bmatrix}$, then the value of $\det(A^4) + \det(A^{10} - (\text{Adj}(2A))^{10})$ is equal to _____.

Response Type : Numeric

Evaluation Required For SA : Yes

Show Word Count : Yes

Answers Type : Equal

Text Areas : PlainText

Possible Answers :

100

Question Number : 82 Question Id : 8643512692 Question Type : SA

Correct Marks : 4 Wrong Marks : 0

जर $A = \begin{bmatrix} 2 & 3 \\ 0 & -1 \end{bmatrix}$, तर $\det(A^4) + \det(A^{10} - (\text{Adj}(2A))^{10})$ चे मूल्य बरोबर _____ आहे.

Response Type : Numeric

Evaluation Required For SA : Yes

Show Word Count : Yes

Answers Type : Equal

Text Areas : PlainText

Possible Answers :

100

Question Number : 83 Question Id : 8643512693 Question Type : SA

Correct Marks : 4 Wrong Marks : 0

If $(2021)^{3762}$ is divided by 17, then the remainder is _____.

Response Type : Numeric

Evaluation Required For SA : Yes

Show Word Count : Yes

Answers Type : Equal

Text Areas : PlainText

Possible Answers :

100

Question Number : 83 Question Id : 8643512693 Question Type : SA

Correct Marks : 4 Wrong Marks : 0

जर $(2021)^{3762}$ हे 17 ने विभाज्य (divided) आहे, तर बाकी (remainder) _____ आहे.

Response Type : Numeric

Evaluation Required For SA : Yes

Show Word Count : Yes

Answers Type : Equal

Text Areas : PlainText

Possible Answers :

100

Question Number : 84 Question Id : 8643512694 Question Type : SA

Correct Marks : 4 Wrong Marks : 0

If the function $f(x) = \frac{\cos(\sin x) - \cos x}{x^4}$ is continuous at each point in its domain and

$f(0) = \frac{1}{k}$, then k is _____.

Response Type : Numeric

Evaluation Required For SA : Yes

Show Word Count : Yes

Answers Type : Equal

Text Areas : PlainText

Possible Answers :

100

Question Number : 84 Question Id : 8643512694 Question Type : SA

Correct Marks : 4 Wrong Marks : 0

$f(x) = \frac{\cos(\sin x) - \cos x}{x^4}$, हे फल एका अधिक्षेत्रामधील प्रत्येक बिंदूवर संतत (continuous) आहे आणि

$f(0) = \frac{1}{k}$, तर k _____ आहे.

Response Type : Numeric

Evaluation Required For SA : Yes

Show Word Count : Yes

Answers Type : Equal

Text Areas : PlainText

Possible Answers :

100

Question Number : 85 **Question Id :** 8643512695 **Question Type :** SA

Correct Marks : 4 **Wrong Marks :** 0

If $[\cdot]$ represents the greatest integer function, then the value of

$\left| \int_0^{\sqrt{\frac{\pi}{2}}} [x^2] - \cos x \, dx \right|$ is _____.

Response Type : Numeric

Evaluation Required For SA : Yes

Show Word Count : Yes

Answers Type : Equal

Text Areas : PlainText

Possible Answers :

100

Question Number : 85 **Question Id :** 8643512695 **Question Type :** SA

Correct Marks : 4 **Wrong Marks :** 0

जर $[\cdot]$ हे महत्तम पूर्णांक (greatest integer) फल दर्शविते, तर $\left| \int_0^{\sqrt{\frac{\pi}{2}}} [x^2] - \cos x \, dx \right|$ चे मूल्य _____

आहे.

Response Type : Numeric

Evaluation Required For SA : Yes

Show Word Count : Yes

Answers Type : Equal

Text Areas : PlainText

Possible Answers :

100

Question Number : 86 Question Id : 8643512696 Question Type : SA**Correct Marks : 4 Wrong Marks : 0**

The minimum distance between any two points P_1 and P_2 while considering point P_1 on one circle and point P_2 on the other circle for the given circles' equations

$$x^2 + y^2 - 10x - 10y + 41 = 0$$

$$x^2 + y^2 - 24x - 10y + 160 = 0 \text{ is } \underline{\hspace{2cm}}.$$

Response Type : Numeric**Evaluation Required For SA : Yes****Show Word Count : Yes****Answers Type : Equal****Text Areas : PlainText****Possible Answers :**

100

Question Number : 86 Question Id : 8643512696 Question Type : SA**Correct Marks : 4 Wrong Marks : 0**

$$x^2 + y^2 - 10x - 10y + 41 = 0,$$

$x^2 + y^2 - 24x - 10y + 160 = 0$ ही वर्तुळांची समीकरणे दिलेली आहेत त्या वेळी P_1 बिंदू एका वर्तुळावर आणि P_2 बिंदू दुसऱ्या वर्तुळावर आहे असे लक्षात घेतले तर, P_1 आणि P_2 या दोन बिंदू मधील किमान (minimum) अंतर आहे.

Response Type : Numeric**Evaluation Required For SA : Yes****Show Word Count : Yes****Answers Type : Equal****Text Areas : PlainText****Possible Answers :**

100

Question Number : 87 Question Id : 8643512697 Question Type : SA**Correct Marks : 4 Wrong Marks : 0**

If the equation of the plane passing through the line of intersection of the planes $2x - 7y + 4z - 3 = 0$, $3x - 5y + 4z + 11 = 0$ and the point $(-2, 1, 3)$ is $ax + by + cz - 7 = 0$, then the value of $2a + b + c - 7$ is .

Response Type : Numeric**Evaluation Required For SA : Yes****Show Word Count : Yes**

Answers Type : Equal

Text Areas : PlainText

Possible Answers :

100

Question Number : 87 Question Id : 8643512697 Question Type : SA

Correct Marks : 4 Wrong Marks : 0

जर $2x - 7y + 4z - 3 = 0$, $3x - 5y + 4z + 11 = 0$ या प्रतलांच्या छेदांची रेषा आणि $(-2, 1, 3)$ या बिंदू मधून जाणाऱ्या प्रतलाचे समीकरण $ax + by + cz - 7 = 0$ आहे, तर $2a + b + c - 7$ चे मूल्य _____ आहे.

Response Type : Numeric

Evaluation Required For SA : Yes

Show Word Count : Yes

Answers Type : Equal

Text Areas : PlainText

Possible Answers :

100

Question Number : 88 Question Id : 8643512698 Question Type : SA

Correct Marks : 4 Wrong Marks : 0

Let there be three independent events E_1 , E_2 and E_3 . The probability that only E_1 occurs is α , only E_2 occurs is β and only E_3 occurs is γ . Let 'p' denote the probability of none of events occurs that satisfies the equations $(\alpha - 2\beta)p = \alpha\beta$ and $(\beta - 3\gamma)p = 2\beta\gamma$. All the given probabilities are assumed to lie in the interval $(0, 1)$.

Then, $\frac{\text{Probability of occurrence of } E_1}{\text{Probability of occurrence of } E_3}$ is equal to _____.

Response Type : Numeric

Evaluation Required For SA : Yes

Show Word Count : Yes

Answers Type : Equal

Text Areas : PlainText

Possible Answers :

100

Question Number : 88 Question Id : 8643512698 Question Type : SA

Correct Marks : 4 Wrong Marks : 0

समजा येथे E_1, E_2 आणि E_3 या तीन अनघिन (independent) घटना आहेत. फक्त E_1 घडण्याची संभाव्यता α , E_2 घडण्याची संभाव्यता β आणि E_3 घडण्याची संभाव्यता γ आहे. समजा कोणतीच घटना न घडण्याची संभाव्यता 'p' दर्शविते व ती $(\alpha - 2\beta)p = \alpha\beta$ आणि $(\beta - 3\gamma)p = 2\beta\gamma$ हे समीकरण सार्थ करते. सर्व संभाव्यता

ह्या (0, 1) मध्ये असतात असे समजा. तर $\frac{E_1$ च्या घडण्याची संभाव्यता}{ E_3 च्या घडण्याची संभाव्यता} _____ असेल.

Response Type : Numeric

Evaluation Required For SA : Yes

Show Word Count : Yes

Answers Type : Equal

Text Areas : PlainText

Possible Answers :

100

Question Number : 89 **Question Id :** 8643512699 **Question Type :** SA

Correct Marks : 4 **Wrong Marks :** 0

If $f(x) = \sin\left(\cos^{-1}\left(\frac{1 - 2^{2x}}{1 + 2^{2x}}\right)\right)$ and its first derivative with respect to x is $-\frac{b}{a}\log_e 2$ when

$x = 1$, where a and b are integers, then the minimum value of $|a^2 - b^2|$ is _____.

Response Type : Numeric

Evaluation Required For SA : Yes

Show Word Count : Yes

Answers Type : Equal

Text Areas : PlainText

Possible Answers :

100

Question Number : 89 **Question Id :** 8643512699 **Question Type :** SA

Correct Marks : 4 **Wrong Marks :** 0

जर $f(x) = \sin\left(\cos^{-1}\left(\frac{1 - 2^{2x}}{1 + 2^{2x}}\right)\right)$ आणि x च्या संदर्भात (with respect) पहिले विकलज (first derivative)

$-\frac{b}{a}\log_e 2$ आहे, तेव्हा $x = 1$ आहे, जेव्हा a आणि b हे पूर्णांक (integers) आहेत, तर $|a^2 - b^2|$ चे किमान मूल्य

(minimum value) _____ आहे.

Response Type : Numeric

Evaluation Required For SA : Yes

Show Word Count : Yes

Answers Type : Equal

Text Areas : PlainText

Possible Answers :

100

Question Number : 90 Question Id : 8643512700 Question Type : SA

Correct Marks : 4 Wrong Marks : 0

$$\text{If } \vec{a} = \alpha \hat{i} + \beta \hat{j} + 3\hat{k},$$

$$\vec{b} = -\beta \hat{i} - \alpha \hat{j} - \hat{k} \text{ and}$$

$$\vec{c} = \hat{i} - 2\hat{j} - \hat{k}$$

such that $\vec{a} \cdot \vec{b} = 1$ and $\vec{b} \cdot \vec{c} = -3$, then $\frac{1}{3}((\vec{a} \times \vec{b}) \cdot \vec{c})$ is equal to _____.

Response Type : Numeric

Evaluation Required For SA : Yes

Show Word Count : Yes

Answers Type : Equal

Text Areas : PlainText

Possible Answers :

100

Question Number : 90 Question Id : 8643512700 Question Type : SA

Correct Marks : 4 Wrong Marks : 0

$$\text{जर } \vec{a} = \alpha \hat{i} + \beta \hat{j} + 3\hat{k},$$

$$\vec{b} = -\beta \hat{i} - \alpha \hat{j} - \hat{k} \text{ आणि}$$

$$\vec{c} = \hat{i} - 2\hat{j} - \hat{k}$$

जसे की $\vec{a} \cdot \vec{b} = 1$ आणि $\vec{b} \cdot \vec{c} = -3$, तर $\frac{1}{3}((\vec{a} \times \vec{b}) \cdot \vec{c})$ बरोबर _____ आहे.

Response Type : Numeric

Evaluation Required For SA : Yes

Show Word Count : Yes

Answers Type : Equal

Text Areas : PlainText

Possible Answers :

100