

National Testing Agency

Question Paper Name :	B TECH EA 18th March 2021 Shift 1
Subject Name :	B TECH EA
Creation Date :	2021-03-18 14:10:31
Duration :	180
Number of Questions :	90
Total Marks :	300
Display Marks:	Yes

B TECH EA

Group Number :	1
Group Id :	86435160
Group Maximum Duration :	0
Group Minimum Duration :	180
Show Attended Group? :	No
Edit Attended Group? :	No
Break time :	0
Group Marks :	300
Is this Group for Examiner? :	No

Physics Section A

Section Id :	864351355
Section Number :	1
Section type :	Online
Mandatory or Optional :	Mandatory
Number of Questions :	20
Number of Questions to be attempted :	20
Section Marks :	80
Mark As Answered Required? :	Yes
Sub-Section Number :	1
Sub-Section Id :	864351355
Question Shuffling Allowed :	Yes

Question Number : 1 Question Id : 8643515311 Question Type : MCQ Option Shuffling : Yes Is Question Mandatory : No Correct Marks : 4 Wrong Marks : 1

An oil drop of radius 2 mm with a density 3 g cm^{-3} is held stationary under a constant electric field $3.55 \times 10^5 \text{ V m}^{-1}$ in the Millikan's oil drop experiment. What is the number of excess electrons that the oil drop will possess ?

Consider $g = 9.81 \text{ m/s}^2$

Options :

86435115931. 17.3×10^{10}

86435115932. 1.73×10^{10}

86435115933. 1.73×10^{12}

86435115934. 48.8×10^{11}

Question Number : 1 Question Id : 8643515311 Question Type : MCQ Option Shuffling : Yes Is Question Mandatory : No

Correct Marks : 4 Wrong Marks : 1

মিলিকানৰ অইল ড্ৰপ পৰীক্ষাত 3 g cm^{-3} ঘনত্বৰ 2 mm ব্যাসাৰ্ধৰ তেলৰ টোপাল এটাক ধ্ৰুৱক বৈদ্যুতিক ক্ষেত্ৰ $3.55 \times 10^5 \text{ V m}^{-1}$ ত স্থিতৱস্থাত ৰখা হৈছে। তেলৰ টোপালটোত থকা বৰ্ধিত ইলেক্ট্ৰনৰ সংখ্যা কি হয় ?

$g = 9.81 \text{ m/s}^2$ লোৱা

Options :

86435115931. 17.3×10^{10}

86435115932. 1.73×10^{10}

86435115933. 1.73×10^{12}

86435115934. 48.8×10^{11}

Question Number : 2 Question Id : 8643515312 Question Type : MCQ Option Shuffling : Yes Is Question Mandatory : No

Correct Marks : 4 Wrong Marks : 1

A constant power delivering machine has towed a box, which was initially at rest, along a horizontal straight line. The distance moved by the box in time 't' is proportional to :

Options :

86435115935. $t^{3/2}$

86435115936. $t^{1/2}$ 86435115937. $t^{2/3}$ 86435115938. t

Question Number : 2 Question Id : 8643515312 Question Type : MCQ Option Shuffling : Yes Is Question Mandatory : No

Correct Marks : 4 Wrong Marks : 1

এডাল আনুভূমিক বেখাৰ দিশত, প্ৰাৰম্ভিকতে স্থিৰ অৱস্থাত থকা এটা বাকচক, ধ্ৰুৱক ক্ষমতা দি থকা যন্ত্ৰ এটাই টানি আছে।

' t ' সময়ত বাকচটোৱে গতি কৰা দূৰত্ব সমানুপাতিক হ'ব :

Options :

86435115935. $t^{3/2}$ 86435115936. $t^{1/2}$ 86435115937. $t^{2/3}$ 86435115938. t

Question Number : 3 Question Id : 8643515313 Question Type : MCQ Option Shuffling : Yes Is Question Mandatory : No

Correct Marks : 4 Wrong Marks : 1

Four identical long solenoids A, B, C and D are connected to each other as shown in the figure. If the magnetic field at the center of A is 3 T, the field at the center of C would be : (Assume that the magnetic field is confined within the volume of respective solenoid).

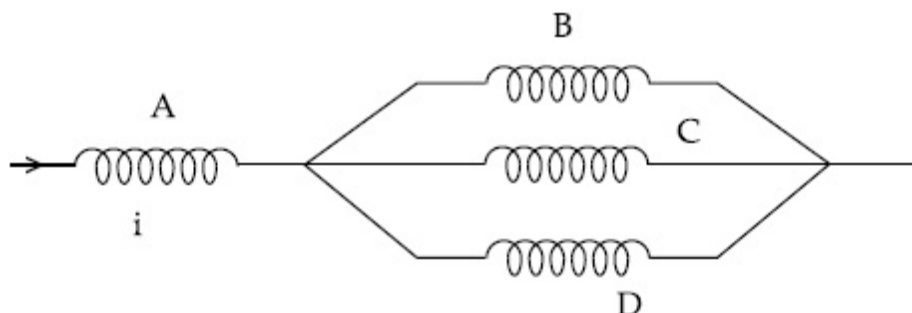

Options :

86435115939. 1 T

86435115940. 9 T

86435115941. 6 T

86435115942. 12 T

Question Number : 3 Question Id : 8643515313 Question Type : MCQ Option Shuffling : Yes Is Question Mandatory : No

Correct Marks : 4 Wrong Marks : 1

চিত্ৰত দেখুওৱা ধৰণে চাৰিটা সাইলাখ একেই দীঘল চ'লেনইড A, B, C আৰু D ক পৰস্পৰৰ সৈতে সংযোগ কৰা হৈছে। যদিহে A ৰ কেন্দ্ৰত চৌম্বিক ক্ষেত্ৰ 3 T হয়, C ৰ কেন্দ্ৰত ক্ষেত্ৰ হ'ব (ধৰি লোৱা যে চৌম্বিক ক্ষেত্ৰ যথাক্ৰমে চলেনইডৰ আয়তনৰ ভিতৰত আৱদ্ধ হৈ আছে)।

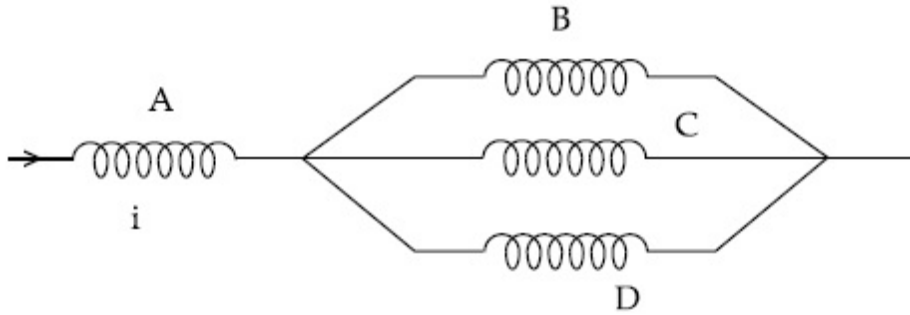

Options :

86435115939. 1 T

86435115940. 9 T

86435115941. 6 T

86435115942. 12 T

Question Number : 4 Question Id : 8643515314 Question Type : MCQ Option Shuffling : Yes Is Question Mandatory : No

Correct Marks : 4 Wrong Marks : 1

The P-V diagram of a diatomic ideal gas system going under cyclic process as shown in figure. The work done during an adiabatic process CD is (use $\gamma = 1.4$) :

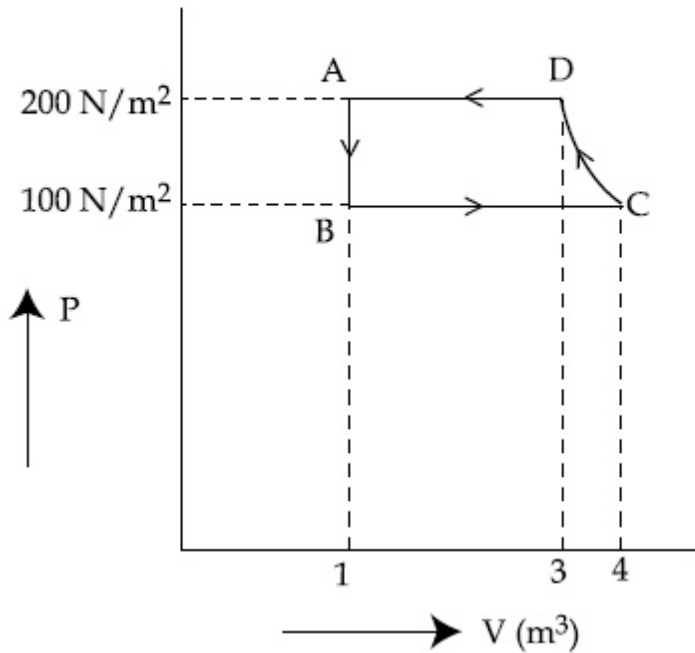

Options :

86435115943. 400 J

86435115944. -500 J

86435115945. 200 J

86435115946. -400 J

Question Number : 4 Question Id : 8643515314 Question Type : MCQ Option Shuffling : Yes Is Question Mandatory : No Correct Marks : 4 Wrong Marks : 1

চক্রীয় প্রণালীত চলি থকা এটা দ্বি পাবমাণৱিক আদৰ্শ গেছৰ নিকায়ৰ P-V লেখচিত্ৰ চিত্ৰত দেখুওৱা হৈছে। এটা তাপবেধী প্রণালী CD ৰ সময়ত সম্পাদিত কাৰ্য হয় ($\gamma = 1.4$ ব্যৱহাৰ কৰা) :

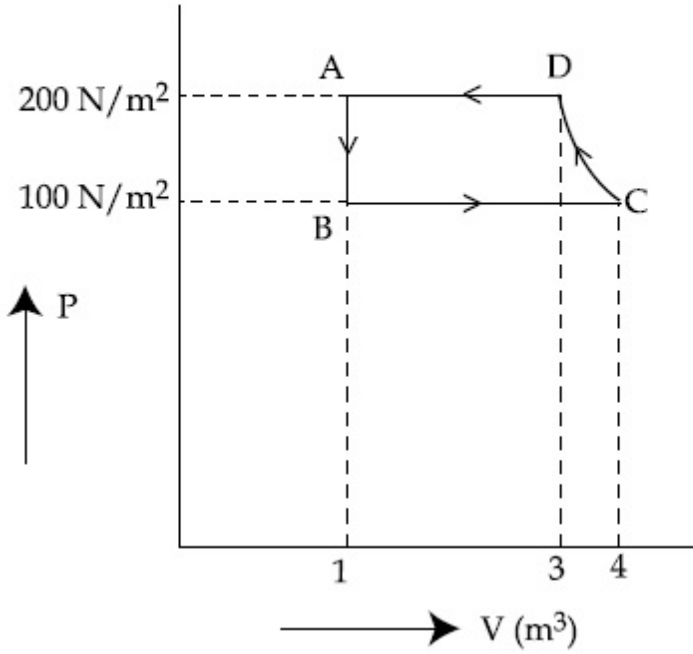

Options :

86435115943. 400 J

86435115944. -500 J

86435115945. 200 J

86435115946. -400 J

Question Number : 5 Question Id : 8643515315 Question Type : MCQ Option Shuffling : Yes Is

Question Mandatory : No

Correct Marks : 4 Wrong Marks : 1

The position, velocity and acceleration of a particle moving with a constant acceleration can be represented by :

Options :

86435115947.

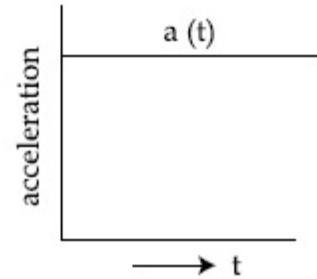
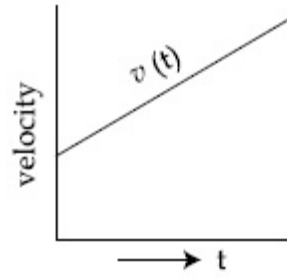
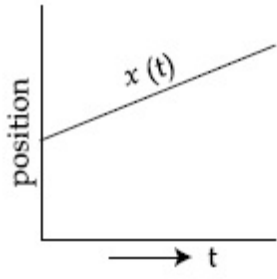

86435115948.

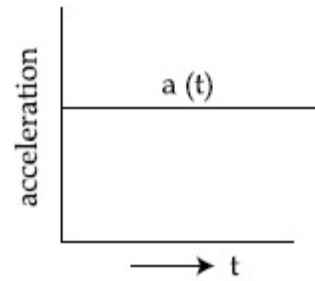
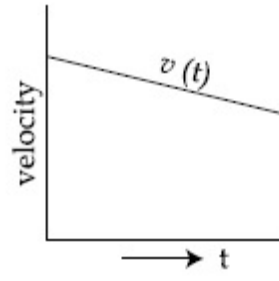
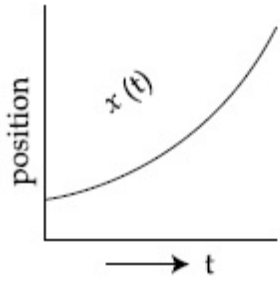

86435115949.

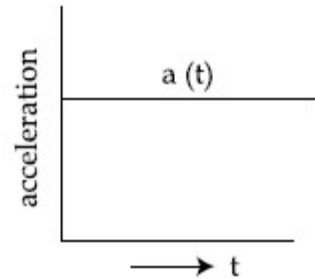
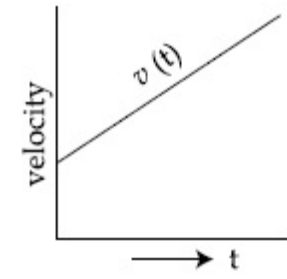
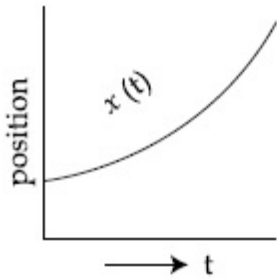

86435115950.

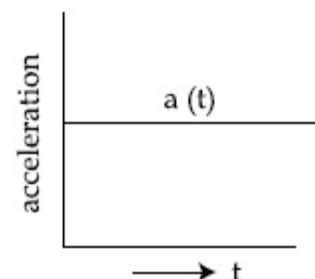
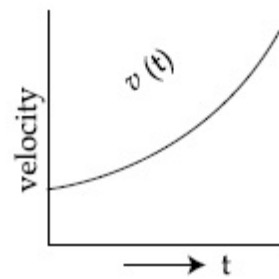
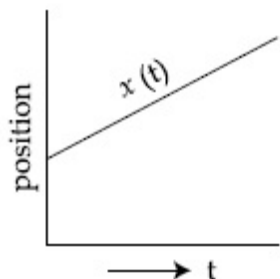

Question Number : 5 Question Id : 8643515315 Question Type : MCQ Option Shuffling : Yes Is Question Mandatory : No

Correct Marks : 4 Wrong Marks : 1

প্রস্রক ত্বরণে গতি কৰি থকা এটা কণাৰ অৱস্থান, বেগ আৰু ত্বৰণ দৰ্শাব পাৰি :

Options :

86435115947.

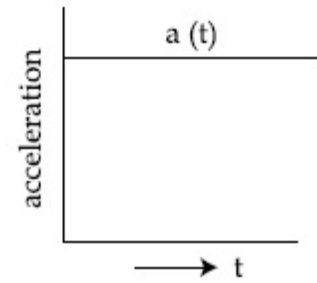
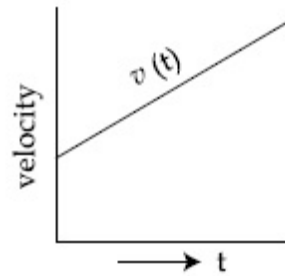
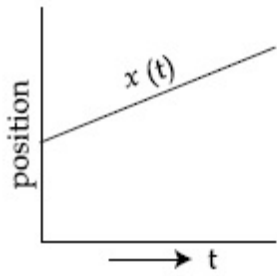

86435115948.

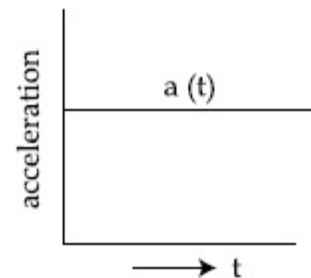
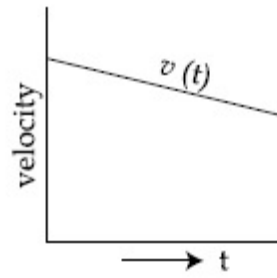
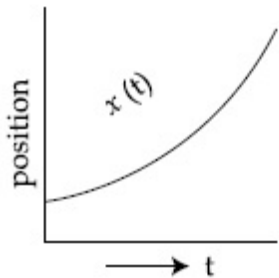

86435115949.

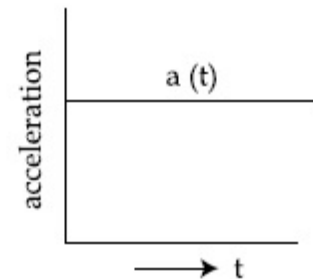
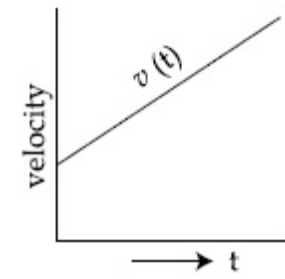
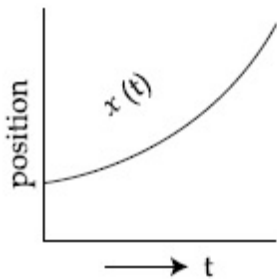

86435115950.

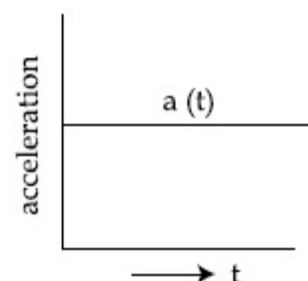
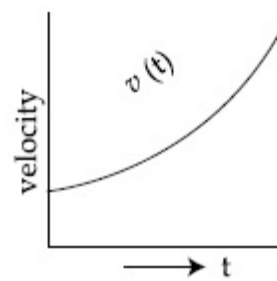
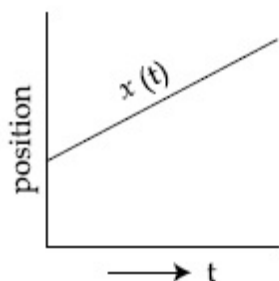

Question Number : 6 Question Id : 8643515316 Question Type : MCQ Option Shuffling : Yes Is

Question Mandatory : No

Correct Marks : 4 Wrong Marks : 1

An AC source rated 220 V, 50 Hz is connected to a resistor. The time taken by the current to change from its maximum to the rms value is :

Options :

86435115951. 2.5 ms

86435115952. 25 ms

86435115953. 0.25 ms

86435115954. 2.5 s

Question Number : 6 Question Id : 8643515316 Question Type : MCQ Option Shuffling : Yes Is**Question Mandatory : No****Correct Marks : 4 Wrong Marks : 1**

এটা বোধকৰ সৈতে 220 V, 50 Hz ৰ এটা পৰিবর্তী প্ৰবাহ উৎস সংযোগ কৰা হ'ল। ইয়াৰ সৰ্বোচ্চ মানৰ পৰা গড় বৰ্গমূল মানলৈ সলনি হ'বলৈ প্ৰবাহে লোৱা সময় :

Options :

86435115951. 2.5 ms

86435115952. 25 ms

86435115953. 0.25 ms

86435115954. 2.5 s

Question Number : 7 Question Id : 8643515317 Question Type : MCQ Option Shuffling : Yes Is**Question Mandatory : No****Correct Marks : 4 Wrong Marks : 1**

In Young's double slit arrangement, slits are separated by a gap of 0.5 mm, and the screen is placed at a distance of 0.5 m from them. The distance between the first and the third bright fringe formed when the slits are illuminated by a monochromatic light of 5890 Å is :

Options :86435115955. 1178×10^{-12} m86435115956. 5890×10^{-7} m86435115957. 1178×10^{-9} m

86435115958. $1178 \times 10^{-6} \text{ m}$

Question Number : 7 Question Id : 8643515317 Question Type : MCQ Option Shuffling : Yes Is Question Mandatory : No

Correct Marks : 4 Wrong Marks : 1

ইয়ঙৰ দ্বি-ছিদ্র ব্যৱস্থাত, ছিদ্র দুটা 0.5 mm ব্যৱধানত ৰখা হৈছে আৰু পৰ্দাখন সিহঁতৰ পৰা 0.5 m দূৰত্বত ৰখা হৈছে। যেতিয়া ছিদ্রদুটা 5890 Å ৰ একবৰ্ণী পোহৰেৰে উজলাই তোলা হয়, গঠন হোৱা প্ৰথম আৰু তৃতীয় উজ্জ্বল পটিৰ মাজৰ দূৰত্ব হয় :

Options :

86435115955. $1178 \times 10^{-12} \text{ m}$

86435115956. $5890 \times 10^{-7} \text{ m}$

86435115957. $1178 \times 10^{-9} \text{ m}$

86435115958. $1178 \times 10^{-6} \text{ m}$

Question Number : 8 Question Id : 8643515318 Question Type : MCQ Option Shuffling : Yes Is Question Mandatory : No

Correct Marks : 4 Wrong Marks : 1

A particle is travelling 4 times as fast as an electron. Assuming the ratio of de-Broglie wavelength of a particle to that of electron is 2 : 1, the mass of the particle is :

Options :

86435115959. 8 times the mass of e^-

86435115960. $\frac{1}{16}$ times the mass of e^-

86435115961. 16 times the mass of e^-

86435115962. $\frac{1}{8}$ times the mass of e^-

Question Number : 8 Question Id : 8643515318 Question Type : MCQ Option Shuffling : Yes Is Question Mandatory : No

Correct Marks : 4 Wrong Marks : 1

এটা কণাই এটা ইলেক্ট্ৰনতলৈ 4 গুণ খৰকৈ গতি কৰিছে। কণাটোৰ দ্য-ব্ৰয়ৰ তৰংগদৈৰ্ঘ্যৰ, ইলেক্ট্ৰনৰ দ্য-ব্ৰয়ৰ তৰংগদৈৰ্ঘ্যৰ সৈতে অনুপাত 2 : 1 বুলি ধৰিলে, কণাটোৰ ভৰ হয় :

Options :

86435115959. e^- ৰ ভৰৰ 8 গুণ

86435115960. e^- ৰ ভৰৰ $\frac{1}{16}$ গুণ

86435115961. e^- ৰ ভৰৰ 16 গুণ

86435115962. e^- ৰ ভৰৰ $\frac{1}{8}$ গুণ

Question Number : 9 Question Id : 8643515319 Question Type : MCQ Option Shuffling : Yes Is Question Mandatory : No

Correct Marks : 4 Wrong Marks : 1

The time period of a simple pendulum is given by $T = 2\pi\sqrt{\frac{l}{g}}$. The measured value of the length of pendulum is 10 cm known to a 1 mm accuracy. The time for 200 oscillations of the pendulum is found to be 100 second using a clock of 1 s resolution. The percentage accuracy in the determination of 'g' using this pendulum is 'x'. The value of 'x' to the nearest integer is,

Options :

86435115963. 2%

86435115964. 3%

86435115965. 4%

86435115966. 5%

Question Number : 9 Question Id : 8643515319 Question Type : MCQ Option Shuffling : Yes Is Question Mandatory : No

Correct Marks : 4 Wrong Marks : 1

এটা সৰলদোলকৰ পৰ্যায়কাল $T = 2\pi\sqrt{\frac{l}{g}}$ । 1 mm শুদ্ধতালৈ মাপ কৰা দোলকটোৰ দৈৰ্ঘ্যৰ মান 10 cm। 1 s বিভেদনৰ এটা ঘড়ী ব্যৱহাৰ কৰি দোলকটোৰ 200 দোলনৰ বাবে সময় পোৱা হৈছে 100 seconds। এই দোলকটো ব্যৱহাৰ কৰি 'g' নিৰ্ণয়ত শতকৰা শুদ্ধতা is 'x'। 'x' ৰ মান নিকটতম পূৰ্ণসংখ্যালৈ :

Options :

86435115963. 2%

86435115964. 3%

86435115965. 4%

86435115966. 5%

Question Number : 10 Question Id : 8643515320 Question Type : MCQ Option Shuffling : Yes Is Question Mandatory : No

Correct Marks : 4 Wrong Marks : 1

Imagine that the electron in a hydrogen atom is replaced by a muon (μ). The mass of muon particle is 207 times that of an electron and charge is equal to the charge of an electron. The ionization potential of this hydrogen atom will be :

Options :

86435115967. 13.6 eV

86435115968. 27.2 eV

86435115969. 331.2 eV

86435115970. 2815.2 eV

Question Number : 10 Question Id : 8643515320 Question Type : MCQ Option Shuffling : Yes Is Question Mandatory : No

Correct Marks : 4 Wrong Marks : 1

কল্পনা কৰা যে এটা হাইড্ৰ'জেন পৰমাণুৰ ইলেক্ট্ৰনটোক এটা মিউৰন (μ , muon) ৰে বিস্থাপিত কৰা হৈছে। মিউৰন কণাৰ ভৰ এটা ইলেক্ট্ৰনৰ 207 গুণ আৰু আধান এটা ইলেক্ট্ৰনৰ আধানৰ সমান। এই হাইড্ৰ'জেন পৰমাণুটোৰ আয়নীকৰণ বিভৱ (ionization potential) হ'ব :

Options :

86435115967. 13.6 eV

86435115968. 27.2 eV

86435115969. 331.2 eV

86435115970. 2815.2 eV

Question Number : 11 Question Id : 8643515321 Question Type : MCQ Option Shuffling : Yes Is Question Mandatory : No

Correct Marks : 4 Wrong Marks : 1

A radioactive sample disintegrates via two independent decay processes having half lives

$T_{1/2}^{(1)}$ and $T_{1/2}^{(2)}$ respectively. The effective half-life, $T_{1/2}$ of the nuclei is :

Options :

86435115971.
$$T_{1/2} = \frac{T_{1/2}^{(1)} T_{1/2}^{(2)}}{T_{1/2}^{(1)} + T_{1/2}^{(2)}}$$

86435115972.
$$T_{1/2} = T_{1/2}^{(1)} + T_{1/2}^{(2)}$$

86435115973.
$$T_{1/2} = \frac{T_{1/2}^{(1)} + T_{1/2}^{(2)}}{T_{1/2}^{(1)} - T_{1/2}^{(2)}}$$

86435115974. None of the above

Question Number : 11 Question Id : 8643515321 Question Type : MCQ Option Shuffling : Yes Is Question Mandatory : No

Correct Marks : 4 Wrong Marks : 1

ক্রমে অৰ্ধায়ু $T_{1/2}^{(1)}$ আৰু $T_{1/2}^{(2)}$ থকা দুটা স্বতন্ত্ৰ পদ্ধতিৰে এটা তেজস্ক্ৰিয় নমুনা বিঘটিত হয়। নিউক্লিয়াছটোৰ কাৰ্যকৰী

(effective) অৰ্ধায়ু, $T_{1/2}$ হয় :

Options :

$$T_{1/2} = \frac{T_{1/2}^{(1)} T_{1/2}^{(2)}}{T_{1/2}^{(1)} + T_{1/2}^{(2)}}$$

86435115971.

$$T_{1/2} = T_{1/2}^{(1)} + T_{1/2}^{(2)}$$

86435115972.

$$T_{1/2} = \frac{T_{1/2}^{(1)} + T_{1/2}^{(2)}}{T_{1/2}^{(1)} - T_{1/2}^{(2)}}$$

86435115973.

86435115974. ওপৰৰ এটাও নহে

Question Number : 12 Question Id : 8643515322 Question Type : MCQ Option Shuffling : Yes Is Question Mandatory : No

Correct Marks : 4 Wrong Marks : 1

A loop of flexible wire of irregular shape carrying current is placed in an external magnetic field. Identify the effect of the field on the wire.

Options :

86435115975. shape of the loop remains unchanged

86435115976. loop assumes circular shape with its plane normal to the field

86435115977. loop assumes circular shape with its plane parallel to the field

86435115978. wire gets stretched to become straight

Question Number : 12 Question Id : 8643515322 Question Type : MCQ Option Shuffling : Yes Is Question Mandatory : No

Correct Marks : 4 Wrong Marks : 1

এখন বাহ্যিক চৌম্বিক ক্ষেত্ৰত, অনিয়মিত আকাৰৰ নমনীয় তাঁৰৰ প্ৰবাহ কঢ়িওৱা এটা লুপ ৰখা হৈছে। তাঁৰডালত ক্ষেত্ৰখনৰ প্ৰভাৱ চিনাক্ত কৰা।

Options :

86435115975. লুপটোৰ আকাৰ অপৰিৱৰ্তিত থাকে।

86435115976. ক্ষেত্রখনৰ লম্বভাৱে ইয়াৰ তল থকাকৈ লুপটোৱে বৃত্তাকাৰ আকাৰ লয়।

86435115977. ক্ষেত্রখনৰ সমান্তৰালভাৱে ইয়াৰ তল থকাকৈ লুপটোৱে বৃত্তাকাৰ আকাৰ লয়।

86435115978. তাঁৰডাল পোন হ'বলৈ টান খায়।

Question Number : 13 Question Id : 8643515323 Question Type : MCQ Option Shuffling : Yes Is Question Mandatory : No

Correct Marks : 4 Wrong Marks : 1

In the experiment of Ohm's law, a potential difference of 5.0 V is applied across the end of a conductor of length 10.0 cm and diameter of 5.00 mm. The measured current in the conductor is 2.00 A. The maximum permissible percentage error in the resistivity of the conductor is :

Options :

86435115979. 3.9

86435115980. 7.5

86435115981. 8.4

86435115982. 3.0

Question Number : 13 Question Id : 8643515323 Question Type : MCQ Option Shuffling : Yes Is Question Mandatory : No

Correct Marks : 4 Wrong Marks : 1

ওমৰ সূত্ৰৰ পৰীক্ষাত, 10.0 cm দৈৰ্ঘ্য আৰু 5.00 mm ব্যাসৰ এক পৰিবাহীৰ দুয়ো প্ৰান্তত 5.0 V ৰ বিভৱভেদ প্ৰয়োগ কৰা হৈছে। পৰিবাহীত প্ৰবাহৰ মান মাপ কৰা হৈছে 2.00 A। পৰিবাহীৰ ৰোধকতাৰ সৰ্বোচ্চ অনুমোদিত শতকৰা ত্ৰুটি

হয় :

Options :

86435115979. 3.9

86435115980. 7.5

86435115981. 8.4

86435115982. 3.0

Question Number : 14 Question Id : 8643515324 Question Type : MCQ Option Shuffling : Yes Is Question Mandatory : No

Correct Marks : 4 Wrong Marks : 1

The time period of a satellite in a circular orbit of radius R is T . The period of another satellite in a circular orbit of radius $9R$ is :

Options :

86435115983. 3 T

86435115984. 9 T

86435115985. 27 T

86435115986. 12 T

Question Number : 14 Question Id : 8643515324 Question Type : MCQ Option Shuffling : Yes Is Question Mandatory : No

Correct Marks : 4 Wrong Marks : 1

R ব্যাসার্ধৰ বৃত্তাকাৰ কক্ষপথত থকা এটা উপগ্রহৰ পৰ্যায়কাল T । $9R$ ব্যাসার্ধৰ কক্ষপথত থকা অন্য এটা উপগ্রহৰ পৰ্যায়কাল হয় :

Options :

86435115983. 3 T

86435115984. 9 T

86435115985. 27 T

86435115986. 12 T

Question Number : 15 Question Id : 8643515325 Question Type : MCQ Option Shuffling : Yes Is Question Mandatory : No

Correct Marks : 4 Wrong Marks : 1

In a series LCR resonance circuit, if we change the resistance only, from a lower to higher value :

Options :

86435115987. The resonance frequency will increase
86435115988. The bandwidth of resonance circuit will increase
86435115989. The quality factor will increase
86435115990. The quality factor and the resonance frequency will remain constant

Question Number : 15 Question Id : 8643515325 Question Type : MCQ Option Shuffling : Yes Is Question Mandatory : No

Correct Marks : 4 Wrong Marks : 1

এটা শ্ৰেণীবদ্ধ LCR অনুদী বৰ্তনীত, যদি আমি নিম্নৰ পৰা উচ্চ মানলৈ, কেৱল ৰোধ পৰিবৰ্তন কৰোঁ :

Options :

86435115987. অনুদী কম্পনাংক বাঢ়ি যাব।
86435115988. অনুদী বৰ্তনীৰ পট্টিবেধ বাঢ়ি যাব।
86435115989. গুণক ৰাশি বাঢ়ি যাব।
86435115990. গুণক ৰাশি আৰু অনুদী কম্পাংক ধ্ৰুৱক হৈ থাকিব।

Question Number : 16 Question Id : 8643515326 Question Type : MCQ Option Shuffling : Yes Is Question Mandatory : No

Correct Marks : 4 Wrong Marks : 1

Your friend is having eye sight problem. She is not able to see clearly a distant uniform window mesh and it appears to her as non-uniform and distorted. The doctor diagnosed the problem as :

Options :

86435115991. Myopia and hypermetropia
86435115992. Presbyopia with Astigmatism

86435115993. Astigmatism

86435115994. Myopia with Astigmatism

Question Number : 16 Question Id : 8643515326 Question Type : MCQ Option Shuffling : Yes Is

Question Mandatory : No

Correct Marks : 4 Wrong Marks : 1

তোমাৰ বন্ধুৰ দৃষ্টিশক্তিৰ সমস্যা হৈছে। তই দূৰত থকা সুষ্ম খিৰিকীৰ জালি এখন দেখিবলৈ অসমৰ্থ আৰু ই তইৰ সম্মুখত অসুযম আৰু বিকৃত ৰূপত ধৰা দিছে। ডাক্তৰে সমস্যাটো নিৰ্ণয় কৰিছে :

Options :

86435115991. মায়'পিয়া/হৃস্বদৃষ্টিদোষ আৰু হাইপাৰমেট্ৰ'পিয়া/দূৰদৃষ্টিদোষ।

86435115992. এছটিগমেটিজম (Astigmatism) ৰ সৈতে প্ৰেছ্বায়পিয়া।

86435115993. এছটিগমেটিজম।

86435115994. এছটিগমেটিজমৰ সৈতে মায়'পিয়া।

Question Number : 17 Question Id : 8643515327 Question Type : MCQ Option Shuffling : Yes Is

Question Mandatory : No

Correct Marks : 4 Wrong Marks : 1

What will be the average value of energy along one degree of freedom for an ideal gas in thermal equilibrium at a temperature T ? (k_B is Boltzmann constant)

Options :

86435115995. $k_B T$

86435115996. $\frac{1}{2} k_B T$

86435115997. $\frac{3}{2} k_B T$

86435115998. $\frac{2}{3} k_B T$

Question Number : 17 Question Id : 8643515327 Question Type : MCQ Option Shuffling : Yes Is Question Mandatory : No

Correct Marks : 4 Wrong Marks : 1

T উষ্ণতাত তাপীয় সাম্যাবস্থাত থকা এটা আদৰ্শ গেছৰ বাবে এটা স্বতন্ত্ৰ মাত্ৰাৰ দিশত শক্তিৰ গড় মান কি হ'ব ?
(বল্টজমেন ধ্ৰুৱক k_B)

Options :

86435115995. $k_B T$

86435115996. $\frac{1}{2} k_B T$

86435115997. $\frac{3}{2} k_B T$

86435115998. $\frac{2}{3} k_B T$

Question Number : 18 Question Id : 8643515328 Question Type : MCQ Option Shuffling : Yes Is Question Mandatory : No

Correct Marks : 4 Wrong Marks : 1

Match List - I with List - II.

List - I

- (a) 10 km height over earth's surface
- (b) 70 km height over earth's surface
- (c) 180 km height over earth's surface
- (d) 270 km height over earth's surface

List - II

- (i) Thermosphere
- (ii) Mesosphere
- (iii) Stratosphere
- (iv) Troposphere

Options :

86435115999. (a)-(iv), (b)-(iii), (c)-(ii), (d)-(i)

86435116000. (a)-(iii), (b)-(ii), (c)-(i), (d)-(iv)

86435116001. (a)-(ii), (b)-(i), (c)-(iv), (d)-(iii)

86435116002. (a)-(i), (b)-(iv), (c)-(iii), (d)-(ii)

Question Number : 18 Question Id : 8643515328 Question Type : MCQ Option Shuffling : Yes Is Question Mandatory : No

Correct Marks : 4 Wrong Marks : 1

তালিকা - I ৰ সৈতে তালিকা - II মিলোৱা :

তালিকা - I

তালিকা - II

- | | |
|--|-----------------------|
| (a) পৃথিৱী পৃষ্ঠৰ ওপৰত 10 km উচ্চতালৈ | (i) থাম'স্ফি়েৰ |
| (b) পৃথিৱী পৃষ্ঠৰ ওপৰত 70 km উচ্চতালৈ | (ii) মেছ'স্ফি়েৰ |
| (c) পৃথিৱী পৃষ্ঠৰ ওপৰত 180 km উচ্চতালৈ | (iii) ষ্ট্ৰেট'স্ফি়েৰ |
| (d) পৃথিৱী পৃষ্ঠৰ ওপৰত 270 km উচ্চতালৈ | (iv) ট্ৰপ'স্ফি়েৰ |

Options :

86435115999. (a)-(iv), (b)-(iii), (c)-(ii), (d)-(i)

86435116000. (a)-(iii), (b)-(ii), (c)-(i), (d)-(iv)

86435116001. (a)-(ii), (b)-(i), (c)-(iv), (d)-(iii)

86435116002. (a)-(i), (b)-(iv), (c)-(iii), (d)-(ii)

Question Number : 19 Question Id : 8643515329 Question Type : MCQ Option Shuffling : Yes Is Question Mandatory : No

Correct Marks : 4 Wrong Marks : 1

A plane electromagnetic wave of frequency 100 MHz is travelling in vacuum along the x-direction. At a particular point in space and time, $\vec{B} = 2.0 \times 10^{-8} \hat{k}$ T. (where, \hat{k} is unit vector along z-direction) What is \vec{E} at this point ?

(speed of light $c = 3 \times 10^8$ m/s)

Options :

86435116003. $0.6 \hat{j}$ V/m

86435116004. $6.0 \hat{j}$ V/m

86435116005. $6.0 \hat{k}$ V/m

86435116006. $0.6 \hat{k} \text{ V/m}$

Question Number : 19 Question Id : 8643515329 Question Type : MCQ Option Shuffling : Yes Is Question Mandatory : No

Correct Marks : 4 Wrong Marks : 1

শূন্যস্থানত x -দিশত 100 MHz কম্পনাংকৰ এক সমতলীয় বিদ্যুৎ চুম্বকীয় তৰংগই গতি কৰি আছে। স্থান আৰু সময়ৰ এক বিশেষ বিন্দুত, $\vec{B} = 2.0 \times 10^{-8} \hat{k} \text{ T}$ । (য'ত \hat{k} , z - দিশত একক ভেক্টৰ)। এই বিন্দুত \vec{E} কি হয় ?

(পোহৰৰ গতিবেগ $c = 3 \times 10^8 \text{ m/s}$)

Options :

86435116003. $0.6 \hat{j} \text{ V/m}$

86435116004. $6.0 \hat{j} \text{ V/m}$

86435116005. $6.0 \hat{k} \text{ V/m}$

86435116006. $0.6 \hat{k} \text{ V/m}$

Question Number : 20 Question Id : 8643515330 Question Type : MCQ Option Shuffling : Yes Is Question Mandatory : No

Correct Marks : 4 Wrong Marks : 1

A thin circular ring of mass M and radius r is rotating about its axis with an angular speed ω . Two particles having mass m each are now attached at diametrically opposite points. The angular speed of the ring will become :

Options :

86435116007. $\omega \frac{M}{M + m}$

86435116008. $\omega \frac{M}{M + 2m}$

86435116009. $\omega \frac{M - 2m}{M + 2m}$

$$\omega \frac{M + 2m}{M}$$

86435116010.

Question Number : 20 Question Id : 8643515330 Question Type : MCQ Option Shuffling : Yes Is Question Mandatory : No

Correct Marks : 4 Wrong Marks : 1

ভৰ M আৰু r ব্যাসাৰ্ধৰ এটা পাতল বৃত্তাকাৰ আঙুঠিয়ে ω কৌণিক দ্ৰুতিৰে ইয়াৰ অক্ষ সাপেক্ষে ঘূৰ্ণন কৰি আছে। প্রতিটো m ভৰৰ দুটা কণাক এতিয়া ব্যাসিকভাৱে বিপৰীত বিন্দুত লগাই দিয়া হ'ল। আঙুঠিটোৰ কৌণিক বেগ হ'বগৈ :

Options :

$$\omega \frac{M}{M + m}$$

86435116007.

$$\omega \frac{M}{M + 2m}$$

86435116008.

$$\omega \frac{M - 2m}{M + 2m}$$

86435116009.

$$\omega \frac{M + 2m}{M}$$

86435116010.

Physics Section B

Section Id :	864351356
Section Number :	2
Section type :	Online
Mandatory or Optional :	Mandatory
Number of Questions :	10
Number of Questions to be attempted :	5
Section Marks :	20
Mark As Answered Required? :	Yes
Sub-Section Number :	1
Sub-Section Id :	864351356
Question Shuffling Allowed :	Yes

Question Number : 21 Question Id : 8643515331 Question Type : SA Correct Marks : 4 Wrong Marks : 0

An npn transistor operates as a common emitter amplifier with a power gain of 10^6 . The input circuit resistance is 100Ω and the output load resistance is $10 \text{ k}\Omega$. The common emitter current gain ' β ' will be _____. (Round off to the Nearest Integer)

Response Type : Numeric

Evaluation Required For SA : Yes

Show Word Count : Yes

Answers Type : Equal

Text Areas : PlainText

Possible Answers :

100

Question Number : 21 Question Id : 8643515331 Question Type : SA

Correct Marks : 4 Wrong Marks : 0

কমন এমিটাৰ পৰিবৰ্ধক ৰূপে এটা npn ট্ৰেঞ্জিষ্টৰে 10^6 ক্ষমতা পৰিবৰ্ধনৰ সৈতে কাৰ্যক্ষম হৈ আছে। বৰ্তনীৰ ইনপুট ৰোধ 100Ω আৰু আউটপুট লোড ৰোধ $10 \text{ k}\Omega$ । কমন এমিটাৰ প্ৰবাহ পৰিবৰ্ধন ' β ' হ'ব _____. (নিকটতম অখণ্ড সংখ্যালৈ গোটকৰণ কৰা)

Response Type : Numeric

Evaluation Required For SA : Yes

Show Word Count : Yes

Answers Type : Equal

Text Areas : PlainText

Possible Answers :

100

Question Number : 22 Question Id : 8643515332 Question Type : SA

Correct Marks : 4 Wrong Marks : 0

A ball of mass 10 kg moving with a velocity $10\sqrt{3}$ m/s along the x -axis, hits another ball of mass 20 kg which is at rest. After the collision, first ball comes to rest while the second ball disintegrates into two equal pieces. One piece starts moving along y -axis with a speed of 10 m/s. The second piece starts moving at an angle of 30° with respect to the x -axis.

The velocity of the ball moving at 30° with x -axis is x m/s.

The configuration of pieces after collision is shown in the figure below.

The value of x to the nearest integer is _____.

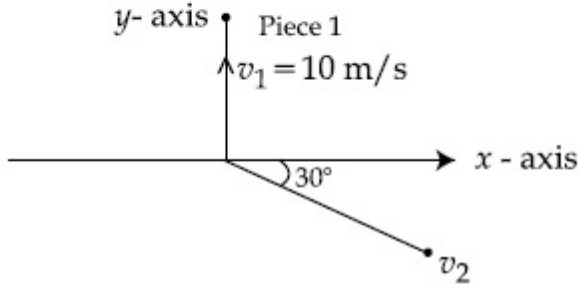

Response Type : Numeric

Evaluation Required For SA : Yes

Show Word Count : Yes

Answers Type : Equal

Text Areas : PlainText

Possible Answers :

100

Question Number : 22 **Question Id :** 8643515332 **Question Type :** SA

Correct Marks : 4 **Wrong Marks :** 0

x -অক্ষৰ দিশত $10\sqrt{3}$ m/s বেগেৰে গতি কৰি থকা 10 kg ভৰৰ এটা বলে, স্থিৰ অৱস্থাত থকা 20 kg ভৰৰ অন্য এটা বলক আঘাত কৰিছে। সংঘাতৰ পিছত প্ৰথম বলটো স্থিতৱস্থালৈ আহে, য'ত নেকি দ্বিতীয় বলটো দুটা সমান টুকুৰাত বিঘটিত হয়। এটুকুৰাই y -অক্ষৰ দিশত 10 m/s দ্ৰুতিৰে গতি কৰিবলৈ আৰম্ভ কৰে। দ্বিতীয় টুকুৰাটোৱে x -অক্ষ অনুযায়ী 30° কোণত গতি কৰিবলৈ আৰম্ভ কৰে। x -অক্ষৰ সৈতে 30° কোণত গতি কৰা বলটোৰ বেগ x m/s। তলৰ চিত্ৰত সংঘাতৰ পিছত টুকুৰাকেইটাৰ বিন্যাস দেখুওৱা হৈছে। নিকটতম পূৰ্ণসংখ্যালৈ x ৰ মান হয় _____।

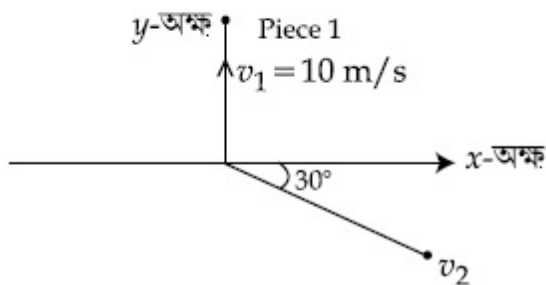

Response Type : Numeric

Evaluation Required For SA : Yes

Show Word Count : Yes

Answers Type : Equal

Text Areas : PlainText

Possible Answers :

100

Question Number : 23 **Question Id :** 8643515333 **Question Type :** SA

Correct Marks : 4 **Wrong Marks :** 0

The voltage across the $10\ \Omega$ resistor in the given circuit is x volt.

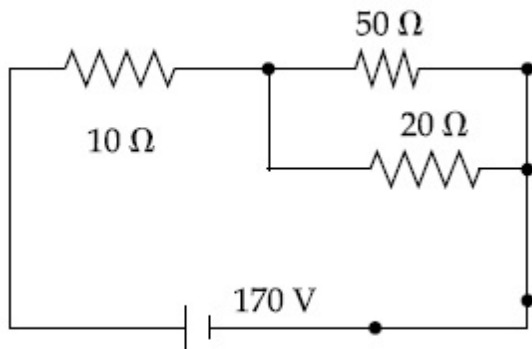

The value of ' x ' to the nearest integer is _____.

Response Type : Numeric

Evaluation Required For SA : Yes

Show Word Count : Yes

Answers Type : Equal

Text Areas : PlainText

Possible Answers :

100

Question Number : 23 **Question Id :** 8643515333 **Question Type :** SA

Correct Marks : 4 **Wrong Marks :** 0

দিয়া বর্তনীটোত $10\ \Omega$ ৰোধকটোৰ দুয়োমূৰে বিভৱ x volt।

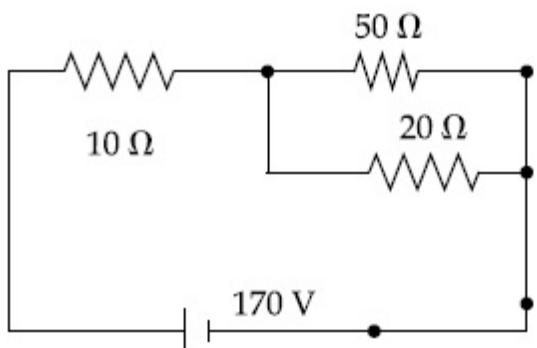

নিকটতম পূৰ্ণসংখ্যালৈ ' x ' ৰ মান _____।

Response Type : Numeric

Evaluation Required For SA : Yes

Show Word Count : Yes

Answers Type : Equal

Text Areas : PlainText

Possible Answers :

100

Question Number : 24 Question Id : 8643515334 Question Type : SA

Correct Marks : 4 Wrong Marks : 0

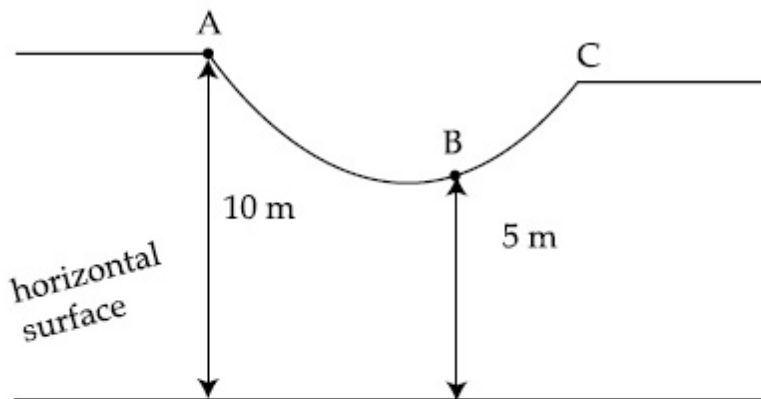

As shown in the figure, a particle of mass 10 kg is placed at a point A. When the particle is slightly displaced to its right, it starts moving and reaches the point B. The speed of the particle at B is x m/s.

(Take $g = 10 \text{ m/s}^2$)

The value of ' x ' to the nearest integer is _____.

Response Type : Numeric

Evaluation Required For SA : Yes

Show Word Count : Yes

Answers Type : Equal

Text Areas : PlainText

Possible Answers :

100

Question Number : 24 Question Id : 8643515334 Question Type : SA

Correct Marks : 4 Wrong Marks : 0

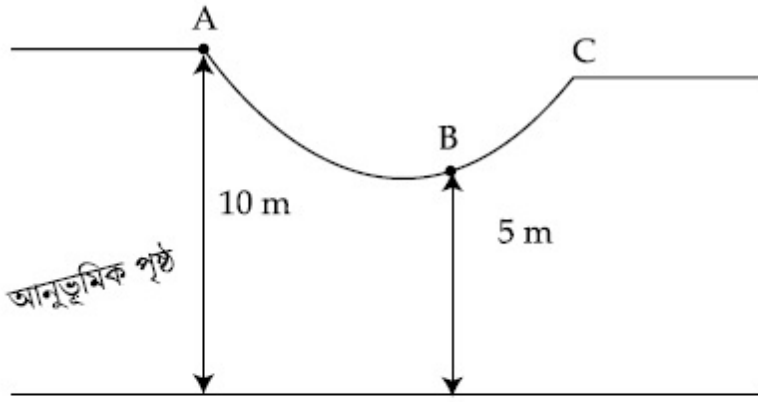

চিত্রত দেখুওৱা ধৰণে, A বিন্দুত 10 kg ভৰৰ এটা কণা ৰখা হৈছে। যেতিয়া কণাটো ইয়াৰ সোঁফালে সামান্যকৈ স্থানান্তৰিত কৰা হয়, ই গতি কৰিবলৈ আৰম্ভ কৰে আৰু B বিন্দু পায়গৈ। B ত কণাটোৰ বেগ x m/s।

($g = 10 \text{ m/s}^2$ লোৱা)

নিকটতম পূৰ্ণসংখ্যালৈ 'x' ৰ মান _____।

Response Type : Numeric

Evaluation Required For SA : Yes

Show Word Count : Yes

Answers Type : Equal

Text Areas : PlainText

Possible Answers :

100

Question Number : 25 **Question Id :** 8643515335 **Question Type :** SA

Correct Marks : 4 **Wrong Marks :** 0

A particle performs simple harmonic motion with a period of 2 second. The time taken by the particle to cover a displacement equal to half of its amplitude from the mean position is

$\frac{1}{a}$ s.

The value of 'a' to the nearest integer is _____.

Response Type : Numeric

Evaluation Required For SA : Yes

Show Word Count : Yes

Answers Type : Equal

Text Areas : PlainText

Possible Answers :

100

Question Number : 25 **Question Id :** 8643515335 **Question Type :** SA

Correct Marks : 4 **Wrong Marks :** 0

2 second ব পর্যায়কালৰ সৈতে এটা কণাই সৰল পৰ্যাবৃত্ত গতি সম্পাদন কৰে। মধ্য অৱস্থানৰ পৰা ইয়াৰ অধিক্ৰান্তৰ

সমান স্থানচ্যুতি সামৰিবলৈ কণাটোৱে লোৱা সময় $\frac{1}{a}$ s।

নিকটতম পূৰ্ণসংখ্যালৈ 'a' ৰ মান _____।

Response Type : Numeric

Evaluation Required For SA : Yes

Show Word Count : Yes

Answers Type : Equal

Text Areas : PlainText

Possible Answers :

100

Question Number : 26 **Question Id :** 8643515336 **Question Type :** SA

Correct Marks : 4 **Wrong Marks :** 0

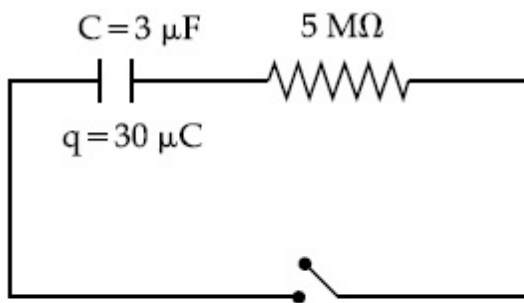

The circuit shown in the figure consists of a charged capacitor of capacity $3 \mu\text{F}$ and a charge of $30 \mu\text{C}$. At time $t=0$, when the key is closed, the value of current flowing through the $5 \text{ M}\Omega$ resistor is ' x ' μA .

The value of ' x ' to the nearest integer is _____.

Response Type : Numeric

Evaluation Required For SA : Yes

Show Word Count : Yes

Answers Type : Equal

Text Areas : PlainText

Possible Answers :

100

Question Number : 26 **Question Id :** 8643515336 **Question Type :** SA

Correct Marks : 4 **Wrong Marks :** 0

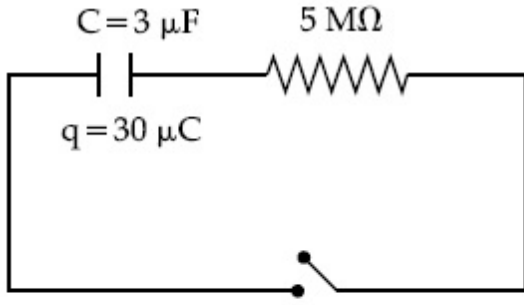

চিত্রত দেখুওৱা বৰ্তনীটো $3 \mu\text{F}$ ধাৰকত্ব আৰু $30 \mu\text{C}$ আধানযুক্ত এটা ধাৰকেৰে গঠিত। $t = 0$ সময়ত, যেতিয়া চাবিটো বন্ধ থাকে, $5 \text{ M}\Omega$ বোধকটোৰ মাজেদি প্ৰৱাহিত প্ৰবাহৰ মান ' x ' μA ।

নিকটতম পূৰ্ণসংখ্যালৈ ' x ' ৰ মান _____।

Response Type : Numeric

Evaluation Required For SA : Yes

Show Word Count : Yes

Answers Type : Equal

Text Areas : PlainText

Possible Answers :

100

Question Number : 27 **Question Id :** 8643515337 **Question Type :** SA

Correct Marks : 4 **Wrong Marks :** 0

A person is swimming with a speed of 10 m/s at an angle of 120° with the flow and reaches to a point directly opposite on the other side of the river. The speed of the flow is ' x ' m/s .

The value of ' x ' to the nearest integer is _____.

Response Type : Numeric

Evaluation Required For SA : Yes

Show Word Count : Yes

Answers Type : Equal

Text Areas : PlainText

Possible Answers :

100

Question Number : 27 **Question Id :** 8643515337 **Question Type :** SA

Correct Marks : 4 **Wrong Marks :** 0

এজন মানুহে 10 m/s দ্ৰুতিৰে সোঁতৰ সৈতে 120° কোণত সাঁতুৰিছে আৰু নদীৰ আনটো পাৰত পোনপটীয়াকৈ বিপৰীতে থকা এটা বিন্দু পাইছেগৈ। সোঁতৰ দ্ৰুতি ' x ' m/s । নিকটতম পূৰ্ণ সংখ্যালৈ ' x ' ৰ মান _____।

Response Type : Numeric

Evaluation Required For SA : Yes

Show Word Count : Yes

Answers Type : Equal

Text Areas : PlainText

Possible Answers :

100

Question Number : 28 Question Id : 8643515338 Question Type : SA

Correct Marks : 4 Wrong Marks : 0

Two separate wires A and B are stretched by 2 mm and 4 mm respectively, when they are subjected to a force of 2 N. Assume that both the wires are made up of same material and the radius of wire B is 4 times that of the radius of wire A. The length of the wires A and B

are in the ratio of $a : b$. Then $\frac{a}{b}$ can be expressed as $\frac{1}{x}$ where x is _____.

Response Type : Numeric

Evaluation Required For SA : Yes

Show Word Count : Yes

Answers Type : Equal

Text Areas : PlainText

Possible Answers :

100

Question Number : 28 Question Id : 8643515338 Question Type : SA

Correct Marks : 4 Wrong Marks : 0

যেতিয়া সিহঁতক 2 N বল দিয়া হয়, দুডাল পৃথক তাঁৰ A আৰু B ক্ৰমে 2 mm আৰু 4 mm ধৰি টান খায়। ধৰি লোৱা দুয়োডাল তাঁৰ একেই পদাৰ্থৰে গঠিত আৰু B তাঁৰডালৰ ব্যাসাৰ্ধ A তাঁৰডালৰ ব্যাসাৰ্ধৰ চাৰিগুণ। A আৰু B তাঁৰডালৰ

দৈৰ্ঘ্যৰ অনুপাত $a : b$ । $\frac{a}{b}$ ক $\frac{1}{x}$ ৰূপে প্ৰকাশ কৰিব পাৰি য'ত x _____।

Response Type : Numeric

Evaluation Required For SA : Yes

Show Word Count : Yes

Answers Type : Equal

Text Areas : PlainText

Possible Answers :

100

Question Number : 29 Question Id : 8643515339 Question Type : SA

Correct Marks : 4 Wrong Marks : 0

A parallel plate capacitor has plate area 100 m^2 and plate separation of 10 m . The space between the plates is filled up to a thickness 5 m with a material of dielectric constant of 10 . The resultant capacitance of the system is ' x ' pF.

The value of $\epsilon_0 = 8.85 \times 10^{-12} \text{ F.m}^{-1}$

The value of ' x ' to the nearest integer is _____.

Response Type : Numeric

Evaluation Required For SA : Yes

Show Word Count : Yes

Answers Type : Equal

Text Areas : PlainText

Possible Answers :

100

Question Number : 29 **Question Id :** 8643515339 **Question Type :** SA

Correct Marks : 4 **Wrong Marks :** 0

এটা সমান্তৰাল পাত ধাৰকৰ পাতৰ কালি 100 m^2 আৰু পাতৰ ব্যৱধান 10 m । পাতদুখনৰ মাজৰ ঠাই 5 m ডাঠ পৰ্য্যন্ত পৰাবৈদ্যুতিক ধ্ৰুৱক 10 ৰ পদাৰ্থৰে ভৰোৱা হয়। নিকায়টোৰ পৰিণামী ধাৰকত্ব ' x ' pF।

ϵ_0 ৰ মান $= 8.85 \times 10^{-12} \text{ F.m}^{-1}$

নিকটতম পূৰ্ণ সংখ্যালৈ ' x ' ৰ মান _____।

Response Type : Numeric

Evaluation Required For SA : Yes

Show Word Count : Yes

Answers Type : Equal

Text Areas : PlainText

Possible Answers :

100

Question Number : 30 **Question Id :** 8643515340 **Question Type :** SA

Correct Marks : 4 **Wrong Marks :** 0

A bullet of mass 0.1 kg is fired on a wooden block to pierce through it, but it stops after moving a distance of 50 cm into it. If the velocity of bullet before hitting the wood is 10 m/s and it slows down with uniform deceleration, then the magnitude of effective retarding force on the bullet is ' x ' N.

The value of ' x ' to the nearest integer is _____.

Response Type : Numeric

Evaluation Required For SA : Yes

Show Word Count : Yes

Answers Type : Equal

Text Areas : PlainText

Possible Answers :

100

Question Number : 30 Question Id : 8643515340 Question Type : SA

Correct Marks : 4 Wrong Marks : 0

0.1 kg ভৰৰ এটা বুলেটক এটা কাঠৰ ব্লকত ইয়াক ভেদ কৰিবলৈ ফায়াৰ কৰা হৈছে, কিন্তু ই 50 cm দূৰত্ব যোৱাৰ পাছত বৈ যায়। যদিহে কাঠত খুন্দিওৱাৰ আগতে বুলেটটোৰ বেগ 10 m/s হয় আৰু ই সুষ্ম ত্বৰণেৰে মূৰ হয়, তেন্তে বুলেটটোত মূৰৰ বল (effective retarding force) হয় 'x' N।

নিকটতম পূৰ্ণ সংখ্যালৈ 'x' ৰ মান _____।

Response Type : Numeric

Evaluation Required For SA : Yes

Show Word Count : Yes

Answers Type : Equal

Text Areas : PlainText

Possible Answers :

100

Chemistry Section A

Section Id :	864351357
Section Number :	3
Section type :	Online
Mandatory or Optional :	Mandatory
Number of Questions :	20
Number of Questions to be attempted :	20
Section Marks :	80
Mark As Answered Required? :	Yes
Sub-Section Number :	1
Sub-Section Id :	864351357
Question Shuffling Allowed :	Yes

Question Number : 31 Question Id : 8643515341 Question Type : MCQ Option Shuffling : Yes Is

Question Mandatory : No

Correct Marks : 4 Wrong Marks : 1

In a binary compound, atoms of element A form a hcp structure and those of element M occupy 2/3 of the tetrahedral voids of the hcp structure. The formula of the binary compound is :

Options :

86435116021. M_2A_3

86435116022. M_4A_3 86435116023. MA_3 86435116024. M_4A

Question Number : 31 Question Id : 8643515341 Question Type : MCQ Option Shuffling : Yes Is Question Mandatory : No

Correct Marks : 4 Wrong Marks : 1

এটা দ্বিউপাংশযুক্ত যৌগত, মৌল A ৰ অণুৱে এটা hcp গঠন কৰে আৰু মৌল M এ hcp গঠনৰ 2/3 চতুৰ্ফলকীয় বন্ধ অধিকাৰ কৰে। দ্বিউপাংশযুক্ত যৌগটোৰ সংকেত হ'ল :

Options :

86435116021. M_2A_3 86435116022. M_4A_3 86435116023. MA_3 86435116024. M_4A

Question Number : 32 Question Id : 8643515342 Question Type : MCQ Option Shuffling : Yes Is Question Mandatory : No

Correct Marks : 4 Wrong Marks : 1

A certain orbital has no angular nodes and two radial nodes. The orbital is :

Options :

86435116025. $2s$ 86435116026. $2p$ 86435116027. $3s$ 86435116028. $3p$

Question Number : 32 Question Id : 8643515342 Question Type : MCQ Option Shuffling : Yes Is

Question Mandatory : No

Correct Marks : 4 Wrong Marks : 1

এটা অৰবিটেলৰ কৌণিক ন'ড নাই আৰু দুটা ব্যাসাঙ্কীয় ন'ড আছে। অৰবিটেলটো :

Options :

86435116025. $2s$

86435116026. $2p$

86435116027. $3s$

86435116028. $3p$

Question Number : 33 Question Id : 8643515343 Question Type : MCQ Option Shuffling : Yes Is Question Mandatory : No

Correct Marks : 4 Wrong Marks : 1

Match List - I with List - II :

List - I (Process)	List - II (Catalyst)
(a) Deacon's process	(i) ZSM-5
(b) Contact process	(ii) CuCl_2
(c) Cracking of hydrocarbons	(iii) Particles 'Ni'
(d) Hydrogenation of vegetable oils	(iv) V_2O_5

Choose the most appropriate answer from the options given below :

Options :

86435116029. (a)-(i), (b)-(iii), (c)-(ii), (d)-(iv)

86435116030. (a)-(iv), (b)-(ii), (c)-(i), (d)-(iii)

86435116031. (a)-(iii), (b)-(i), (c)-(iv), (d)-(ii)

86435116032. (a)-(ii), (b)-(iv), (c)-(i), (d)-(iii)

Question Number : 33 Question Id : 8643515343 Question Type : MCQ Option Shuffling : Yes Is Question Mandatory : No

Correct Marks : 4 Wrong Marks : 1

তালিকা - I ক তালিকা - II ৰ সৈতে মিলন কৰা :

তালিকা - I (পদ্ধতি)	তালিকা - II (অনুঘটক)
(a) ডেক'নছ পদ্ধতি	(i) ZSM-5
(b) কণ্টেক্ট পদ্ধতি	(ii) CuCl_2
(c) হাইড্ৰকাৰ্বন ভঙা	(iii) 'Ni' কণা
(d) বনস্পতি তেলৰ হাইড্ৰজেন যোগকৰণ	(iv) V_2O_5

নিম্নলিখিত বিকল্পবপৰা আটাইতকৈ উপযুক্ত উত্তৰ বাচি উলিওৱা :

Options :

86435116029. (a)-(i), (b)-(iii), (c)-(ii), (d)-(iv)

86435116030. (a)-(iv), (b)-(ii), (c)-(i), (d)-(iii)

86435116031. (a)-(iii), (b)-(i), (c)-(iv), (d)-(ii)

86435116032. (a)-(ii), (b)-(iv), (c)-(i), (d)-(iii)

Question Number : 34 Question Id : 8643515344 Question Type : MCQ Option Shuffling : Yes Is

Question Mandatory : No

Correct Marks : 4 Wrong Marks : 1

The ionic radius of Na^+ ion is 1.02 \AA . The ionic radii (in \AA) of Mg^{2+} and Al^{3+} , respectively, are :

Options :

86435116033. 0.85 and 0.99

86435116034. 0.72 and 0.54

86435116035. 0.68 and 0.72

86435116036. 1.05 and 0.99

Question Number : 34 Question Id : 8643515344 Question Type : MCQ Option Shuffling : Yes Is

Question Mandatory : No

Correct Marks : 4 Wrong Marks : 1

Na⁺ আয়নৰ আয়নীয় ব্যাসার্ধ 1.02 Å । Mg²⁺ আৰু Al³⁺ ৰ আয়নীয় ব্যাসার্ধ (Å ত) যথাক্রমে :

Options :

86435116033. 0.85 আৰু 0.99

86435116034. 0.72 আৰু 0.54

86435116035. 0.68 আৰু 0.72

86435116036. 1.05 আৰু 0.99

Question Number : 35 Question Id : 8643515345 Question Type : MCQ Option Shuffling : Yes Is Question Mandatory : No

Correct Marks : 4 Wrong Marks : 1

The chemical that is added to reduce the melting point of the reaction mixture during the extraction of aluminium is :

Options :

86435116037. Bauxite

86435116038. Kaolite

86435116039. Calamine

86435116040. Cryolite

Question Number : 35 Question Id : 8643515345 Question Type : MCQ Option Shuffling : Yes Is Question Mandatory : No

Correct Marks : 4 Wrong Marks : 1

এলুমিনিয়ামৰ নিষ্কাশণত বিক্রিয়া মিশ্রটোৰ গলনাংক কম কৰিবলৈ যোগ কৰা ৰসায়নিক দ্ৰৱটো হ'ল :

Options :

86435116037. বক্সাইট

86435116038. কেণ্ডলাইট

86435116039. কেলমাইন

86435116040. ক্রাইঅ'লাইট

Question Number : 36 Question Id : 8643515346 Question Type : MCQ Option Shuffling : Yes Is Question Mandatory : No

Correct Marks : 4 Wrong Marks : 1

Given below are two Statements : One is labelled as Assertion A and the other is labelled as Reason R :

Assertion A : During the boiling of water having temporary hardness, $Mg(HCO_3)_2$ is converted to $MgCO_3$.

Reason R : The solubility product of $Mg(OH)_2$ is greater than that of $MgCO_3$.

In the light of the above statements, choose the most appropriate answer from the options given below :

Options :

86435116041. Both A and R are true and R is the correct explanation of A

86435116042. Both A and R are true but R is NOT the correct explanation of A

86435116043. A is true but R is false

86435116044. A is false but R is true

Question Number : 36 Question Id : 8643515346 Question Type : MCQ Option Shuffling : Yes Is Question Mandatory : No

Correct Marks : 4 Wrong Marks : 1

তলত দুটা উক্তি দিয়া হ'ল। এটাক নিশ্চয়োক্তি A আৰু আনটো কাৰণ R হিচাবে চিহ্নিত কৰা হৈছে।

নিশ্চয়োক্তি A : অস্থায়ী কঠিনতা থকা কঠিন পানীক গৰম কৰাৰ সময়ছোৱাত, $Mg(HCO_3)_2$, $MgCO_3$ লৈ পৰিবৰ্তিত হয়।

কাৰণ R : $Mg(OH)_2$ ৰ দ্রৱণীয়তা গুণাংক $MgCO_3$ তকৈ বেছি।

ওপৰৰ উক্তিৰ আলমত, নিম্নলিখিত বিকল্পৰপৰা আটাইতকৈ উপযুক্ত উত্তৰটো বাছি উলিওৱা :

Options :

86435116041. A আৰু R দুয়োটাই সত্য আৰু R হ'ল A ৰ শুদ্ধ ব্যাখ্যা।

86435116042. A আৰু R দুয়োটাই সত্য কিন্তু R, A ৰ শুদ্ধ ব্যাখ্যা নহয়।
86435116043. A সত্য কিন্তু R অসত্য।
86435116044. A অসত্য কিন্তু R সত্য।

Question Number : 37 Question Id : 8643515347 Question Type : MCQ Option Shuffling : Yes Is Question Mandatory : No

Correct Marks : 4 Wrong Marks : 1

Match List - I with List - II :

List - I	List - II
(a) Ca(OCl)_2	(i) Antacid
(b) $\text{CaSO}_4 \cdot \frac{1}{2}\text{H}_2\text{O}$	(ii) Cement
(c) CaO	(iii) Bleach
(d) CaCO_3	(iv) Plaster of Paris

Choose the most appropriate answer from the options given below :

Options :

86435116045. (a)-(i), (b)-(iv), (c)-(iii), (d)-(ii)
86435116046. (a)-(iii), (b)-(ii), (c)-(i), (d)-(iv)
86435116047. (a)-(iii), (b)-(ii), (c)-(iv), (d)-(i)
86435116048. (a)-(iii), (b)-(iv), (c)-(ii), (d)-(i)

Question Number : 37 Question Id : 8643515347 Question Type : MCQ Option Shuffling : Yes Is Question Mandatory : No

Correct Marks : 4 Wrong Marks : 1

তালিকা - I ক তালিকা - II ৰ সৈতে মিলন কৰা :

তালিকা - I	তালিকা - II
(a) Ca(OCl)_2	(i) এছিড প্রতিৰোধী দৰৱ
(b) $\text{CaSO}_4 \cdot \frac{1}{2}\text{H}_2\text{O}$	(ii) চিমেন্ট
(c) CaO	(iii) বিৰঞ্জন
(d) CaCO_3	(iv) প্লাষ্টাৰ অৱ পেৰিছ

নিম্নলিখিত বিকল্পৰপৰা আটাইতকৈ উপযুক্ত উত্তৰটো বাছি উলিওৱা :

Options :

86435116045. (a)-(i), (b)-(iv), (c)-(iii), (d)-(ii)

86435116046. (a)-(iii), (b)-(ii), (c)-(i), (d)-(iv)

86435116047. (a)-(iii), (b)-(ii), (c)-(iv), (d)-(i)

86435116048. (a)-(iii), (b)-(iv), (c)-(ii), (d)-(i)

Question Number : 38 Question Id : 8643515348 Question Type : MCQ Option Shuffling : Yes Is Question Mandatory : No

Correct Marks : 4 Wrong Marks : 1

The number of ionisable hydrogens present in the product obtained from a reaction of phosphorus trichloride and phosphonic acid is :

Options :

86435116049. 1

86435116050. 2

86435116051. 0

86435116052. 3

Question Number : 38 Question Id : 8643515348 Question Type : MCQ Option Shuffling : Yes Is Question Mandatory : No

Correct Marks : 4 Wrong Marks : 1

ফছফৰাছ টুইক্লৰাইড আৰু ফছফনিক এছিডৰ মাজত বিক্ৰিয়াত উৎপন্ন হোৱা জাতদ্ৰব্যত উপস্থিত থকা আয়নীকৰণ সম্ভৱ হাইড্ৰজেনৰ সংখ্যা :

Options :

86435116049. 1

86435116050. 2

86435116051. 0

86435116052. 3

Question Number : 39 Question Id : 8643515349 Question Type : MCQ Option Shuffling : Yes Is Question Mandatory : No

Correct Marks : 4 Wrong Marks : 1

Match List - I with List - II :

List - I	List - II
(a) Chlorophyll	(i) Ruthenium
(b) Vitamin - B ₁₂	(ii) Platinum
(c) Anticancer drug	(iii) Cobalt
(d) Grubbs catalyst	(iv) Magnesium

Choose the most appropriate answer from the options given below :

Options :

86435116053. (a)-(iii), (b)-(ii), (c)-(iv), (d)-(i)

86435116054. (a)-(iv), (b)-(iii), (c)-(ii), (d)-(i)

86435116055. (a)-(iv), (b)-(ii), (c)-(iii), (d)-(i)

86435116056. (a)-(iv), (b)-(iii), (c)-(i), (d)-(ii)

Question Number : 39 Question Id : 8643515349 Question Type : MCQ Option Shuffling : Yes Is Question Mandatory : No

Correct Marks : 4 Wrong Marks : 1

তালিকা - I ক তালিকা - II ৰ সৈতে মিলন কৰা :

তালিকা - I	তালিকা - II
(a) ক্ল'ৰ'ফিল	(i) কথেনিয়াম
(b) ভিটামিন - B ₁₂	(ii) প্লেটিনাম
(c) কৰ্কটৰোগৰোধী ঔষধ	(iii) ক'বাল্ট
(d) গ্ৰাবৰ অনুঘটক	(iv) মেগনেছিয়াম

নিম্নলিখিত বিকল্পৰপৰা আটাইতকৈ উপযুক্ত উত্তৰ বাছি উলিওৱা :

Options :

86435116053. (a)-(iii), (b)-(ii), (c)-(iv), (d)-(i)

86435116054. (a)-(iv), (b)-(iii), (c)-(ii), (d)-(i)

86435116055. (a)-(iv), (b)-(ii), (c)-(iii), (d)-(i)

86435116056. (a)-(iv), (b)-(iii), (c)-(i), (d)-(ii)

Question Number : 40 Question Id : 8643515350 Question Type : MCQ Option Shuffling : Yes Is Question Mandatory : No

Correct Marks : 4 Wrong Marks : 1

The correct structures of trans-[NiBr₂(PPh₃)₂] and meridional-[Co(NH₃)₃(NO₂)₃], respectively, are :

Options :

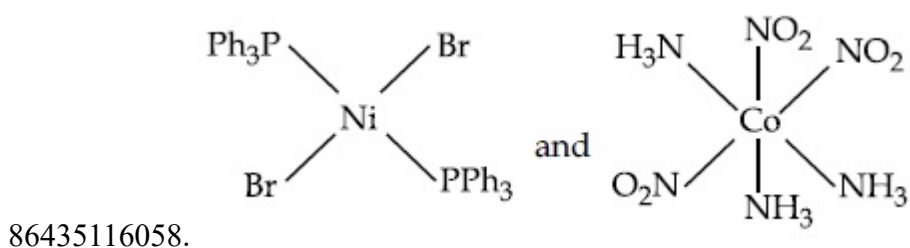
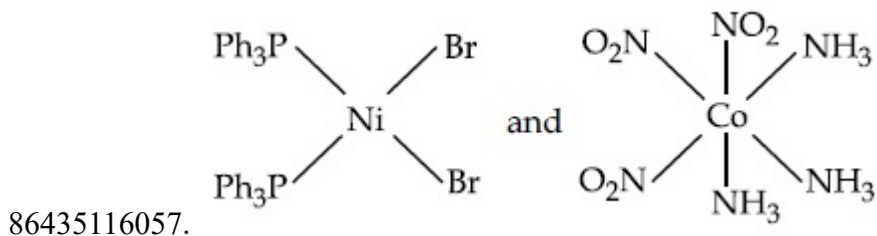

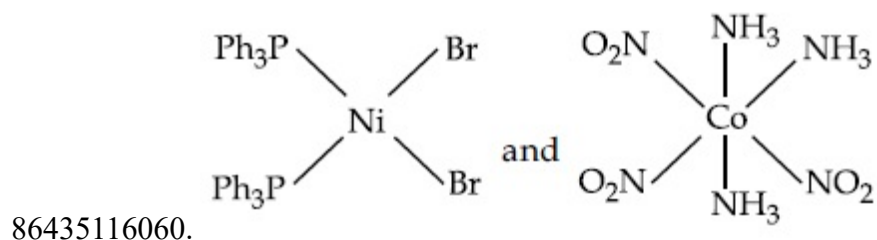
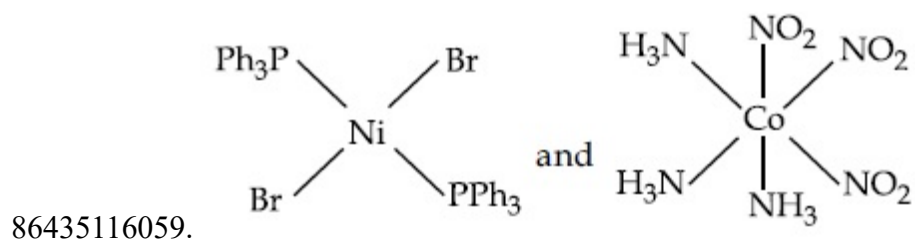

Question Number : 40 Question Id : 8643515350 Question Type : MCQ Option Shuffling : Yes Is Question Mandatory : No Correct Marks : 4 Wrong Marks : 1

ট্রেন্স-[NiBr₂(PPh₃)₂] আৰু মধ্যৰৈখিক-[Co(NH₃)₃(NO₂)₃] ৰ শুদ্ধ গঠন যথাক্রমে হ'ল :

Options :

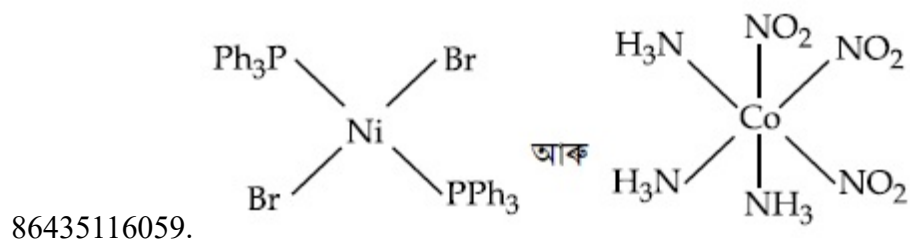
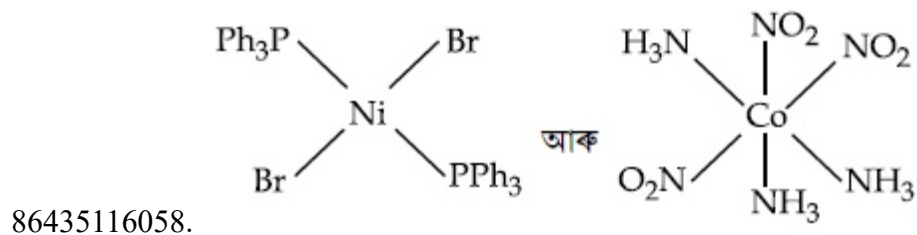
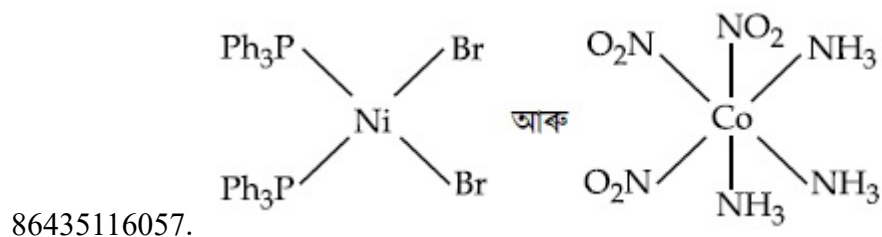

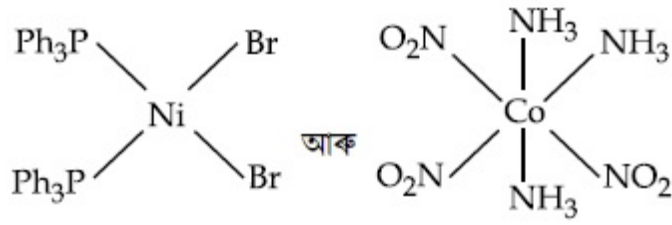

86435116060.

Question Number : 41 Question Id : 8643515351 Question Type : MCQ Option Shuffling : Yes Is Question Mandatory : No

Correct Marks : 4 Wrong Marks : 1

The statements that are TRUE :

- (A) methane leads to both global warming and photochemical smog
- (B) methane is generated from paddy fields
- (C) methane is a stronger global warming gas than CO₂
- (D) methane is a part of reducing smog.

Choose the most appropriate answer from the options given below :

Options :

86435116061. (A) and (B) only

86435116062. (A), (B), (C) only

86435116063. (B), (C), (D) only

86435116064. (A), (B), (D) only

Question Number : 41 Question Id : 8643515351 Question Type : MCQ Option Shuffling : Yes Is Question Mandatory : No

Correct Marks : 4 Wrong Marks : 1

সত্য উক্তিবিবৰ হ'ল :

- (A) মিথেনে গোলকীয় তাপ বৃদ্ধি আৰু আলোক বাসায়নিক ধূৱলী, দুয়োটাতে অবিহণা যোগায়
- (B) মিথেন শস্য পথাৰৰ পৰা উৎপন্ন হয়
- (C) মিথেন CO₂ তকৈ শক্তিশালী গোলকীয় তাপ বৃদ্ধি কৰা গেছ
- (D) মিথেন বিজাৰিত ধূৱলী গঠনৰ এটা অংশ

তলত দিয়া বিকল্পৰপৰা আটাইতকৈ উপযুক্ত উত্তৰটো বাছি উলিওৱা :

Options :

86435116061. (A) আৰু (B) মাত্ৰ

86435116062. (A), (B), (C) মাত্ৰ

86435116063. (B), (C), (D) মাত্ৰ

86435116064. (A), (B), (D) মাত্ৰ

Question Number : 42 Question Id : 8643515352 Question Type : MCQ Option Shuffling : Yes Is Question Mandatory : No

Correct Marks : 4 Wrong Marks : 1

Compound with molecular formula C_3H_6O can show :

Options :

86435116065. Positional isomerism

86435116066. Functional group isomerism

86435116067. Metamerism

86435116068. Both positional isomerism and metamerism

Question Number : 42 Question Id : 8643515352 Question Type : MCQ Option Shuffling : Yes Is Question Mandatory : No

Correct Marks : 4 Wrong Marks : 1

আণৱিক সূত্ৰ C_3H_6O ৰ যৌগই দেখুৱাব পাৰে :

Options :

86435116065. অৱস্থানীয় সমযোগিতা

86435116066. কাৰ্য্যকৰীমূলক সমযোগিতা

86435116067. মেটামেৰিজম

86435116068. অৱস্থানীয় সমযোগিতা আৰু মেটামেৰিজম দুয়োটা

Question Number : 43 Question Id : 8643515353 Question Type : MCQ Option Shuffling : Yes Is

Question Mandatory : No

Correct Marks : 4 Wrong Marks : 1

Match List - I with List - II :

List - I

(Chemicals)

- (a) Alcoholic potassium hydroxide
 (b) Pd/BaSO₄
 (c) BHC (Benzene hexachloride)
 (d) Polyacetylene

List - II

(Use/Preparation/Constituent)

- (i) electrodes in batteries
 (ii) obtained by addition reaction
 (iii) used for β -elimination reaction
 (iv) Lindlar's Catalyst

Choose the most appropriate match :

Options :

86435116069. (a)-(ii), (b)-(i), (c)-(iv), (d)-(iii)

86435116070. (a)-(iii), (b)-(i), (c)-(iv), (d)-(ii)

86435116071. (a)-(ii), (b)-(iv), (c)-(i), (d)-(iii)

86435116072. (a)-(iii), (b)-(iv), (c)-(ii), (d)-(i)

Question Number : 43 Question Id : 8643515353 Question Type : MCQ Option Shuffling : Yes Is

Question Mandatory : No

Correct Marks : 4 Wrong Marks : 1

তালিকা - I ক তালিকা - II ৰ সৈতে মিলন কৰা :

তালিকা - I

(ৰসায়নিক দ্ৰব্য)

- (a) এলক'হ'লিক পটাছিয়াম হাইড্ৰক্সাইড
 (b) Pd/BaSO₄
 (c) BHC (বেনযিন হেক্সাক্লৰাইড)
 (d) পলিএছিটাইলিন

তালিকা - II

(ব্যৱহাৰ/প্ৰস্তুতি/উপাদান)

- (i) বেটাৰীৰ ইলেক্ট্ৰড
 (ii) যোগাত্মক বিক্ৰিয়া
 (iii) β -অপসাৰণ বিক্ৰিয়া
 (iv) লিণ্ডলাৰৰ অনুঘটক

আটাইতকৈ উপযুক্ত মিলনটো বাছি উলিওৱা :

Options :

86435116069. (a)-(ii), (b)-(i), (c)-(iv), (d)-(iii)

86435116070. (a)-(iii), (b)-(i), (c)-(iv), (d)-(ii)

86435116071. (a)-(ii), (b)-(iv), (c)-(i), (d)-(iii)

86435116072. (a)-(iii), (b)-(iv), (c)-(ii), (d)-(i)

Question Number : 44 Question Id : 8643515354 Question Type : MCQ Option Shuffling : Yes Is Question Mandatory : No

Correct Marks : 4 Wrong Marks : 1

Reaction of Grignard reagent, C_2H_5MgBr with C_8H_8O followed by hydrolysis gives compound "A" which reacts instantly with Lucas reagent to give compound B, $C_{10}H_{13}Cl$.

The Compound B is :

Options :

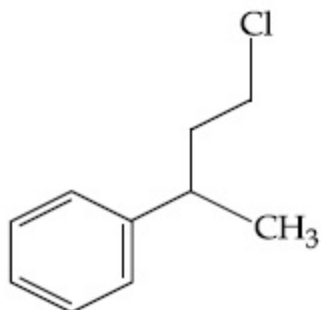

86435116073.

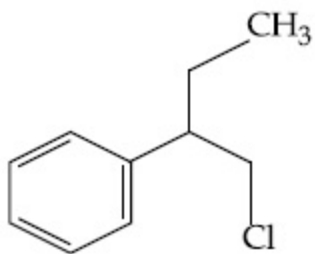

86435116074.

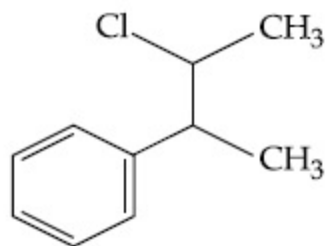

86435116075.

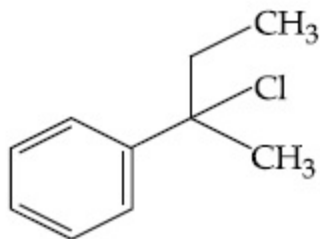

86435116076.

Question Number : 44 Question Id : 8643515354 Question Type : MCQ Option Shuffling : Yes Is Question Mandatory : No

Correct Marks : 4 Wrong Marks : 1

গ্রিনাৰ্ড বিকাৰক, C_2H_5MgBr ক C_8H_8O ৰ লগত বিক্ৰিয়া কৰি, জল বিশ্লেষণৰ পাচত দিয়ে যৌগ "A", যিয়ে পলকতে লুকাছ বিকাৰকৰ লগত বিক্ৰিয়া কৰি উৎপন্ন কৰে যৌগ B, $C_{10}H_{13}Cl$ । যৌগ B হ'ল :

Options :

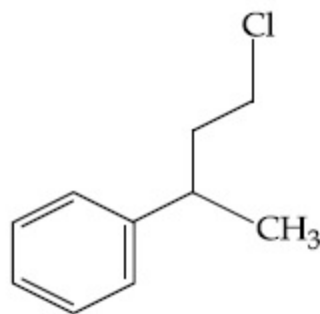

86435116073.

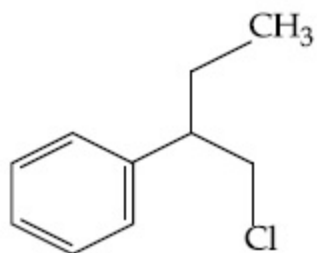

86435116074.

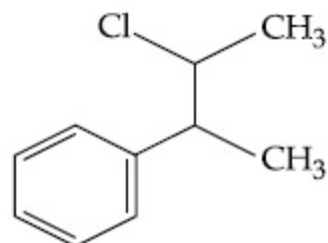

86435116075.

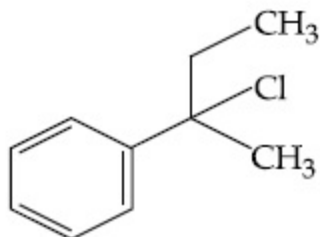

86435116076.

Question Number : 45 Question Id : 8643515355 Question Type : MCQ Option Shuffling : Yes Is Question Mandatory : No

Correct Marks : 4 Wrong Marks : 1

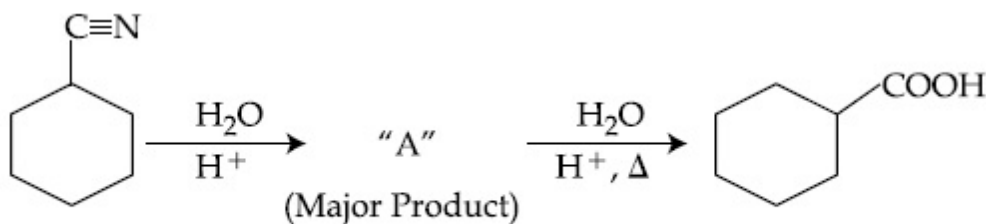

Consider the above chemical reaction and identify product "A" :

Options :

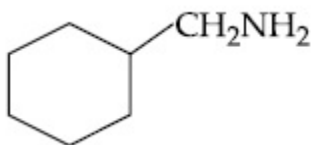

86435116077.

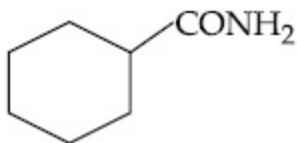

86435116078.

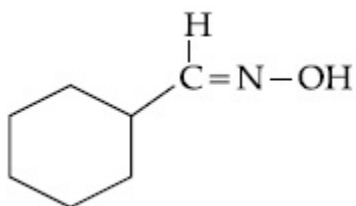

86435116079.

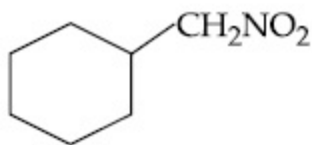

86435116080.

Question Number : 45 Question Id : 8643515355 Question Type : MCQ Option Shuffling : Yes Is

Question Mandatory : No

Correct Marks : 4 Wrong Marks : 1

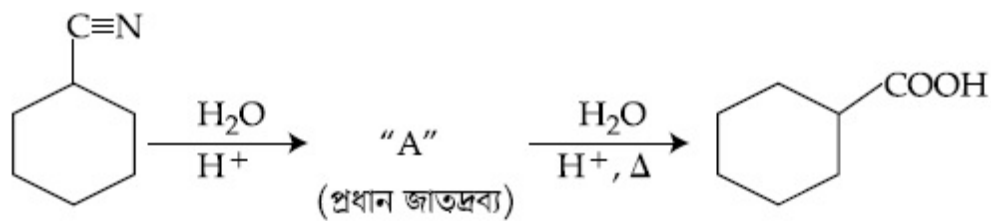

ওপৰৰ ৰাসায়নিক বিক্ৰিয়াটো মানি বিক্ৰিয়াজাত পদাৰ্থ "A" চিনাক্ত কৰা :

Options :

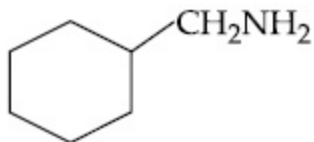

86435116077.

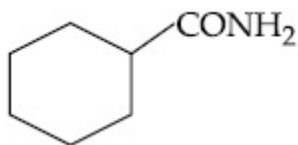

86435116078.

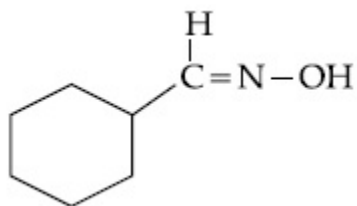

86435116079.

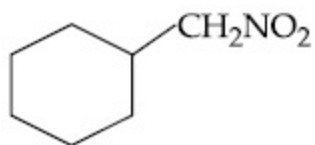

86435116080.

Question Number : 46 Question Id : 8643515356 Question Type : MCQ Option Shuffling : Yes Is

Question Mandatory : No

Correct Marks : 4 Wrong Marks : 1

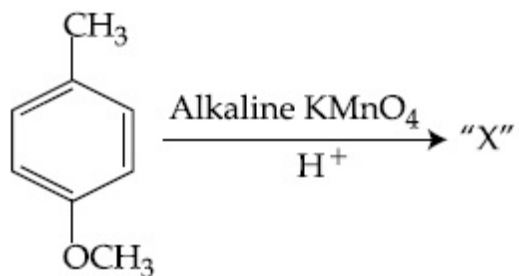

Considering the above chemical reaction, identify the product "X" :

Options :

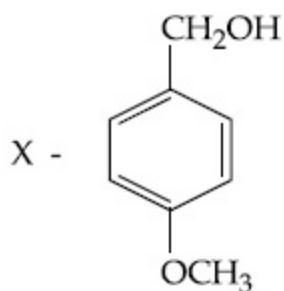

86435116081.

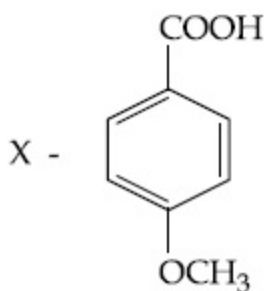

86435116082.

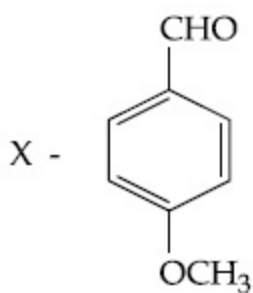

86435116083.

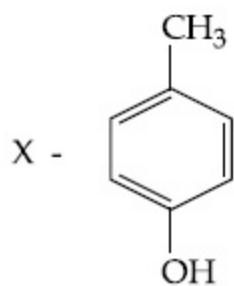

86435116084.

Question Mandatory : No

Correct Marks : 4 Wrong Marks : 1

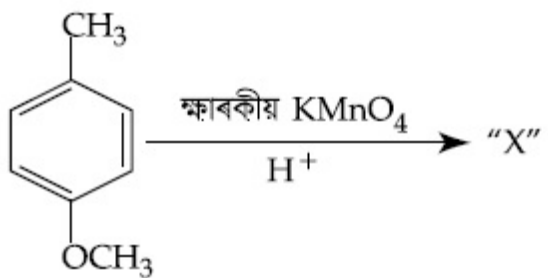

ওপৰৰ বিক্ৰিয়া অনুসৰি জাতদ্রব্য "X" চিনাক্ত কৰা :

Options :

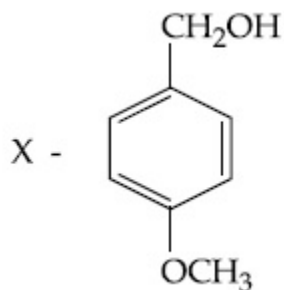

86435116081.

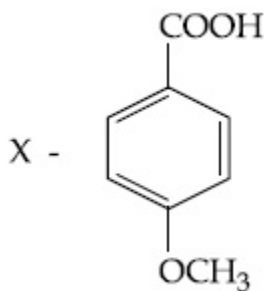

86435116082.

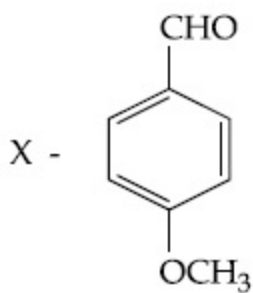

86435116083.

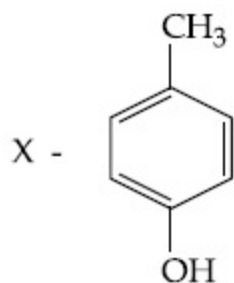

86435116084.

Question Number : 47 Question Id : 8643515357 Question Type : MCQ Option Shuffling : Yes Is Question Mandatory : No Correct Marks : 4 Wrong Marks : 1

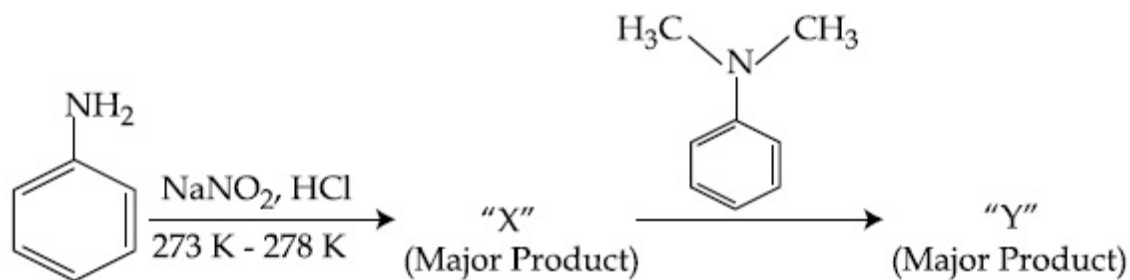

Considering the above reaction, X and Y respectively are :

Options :

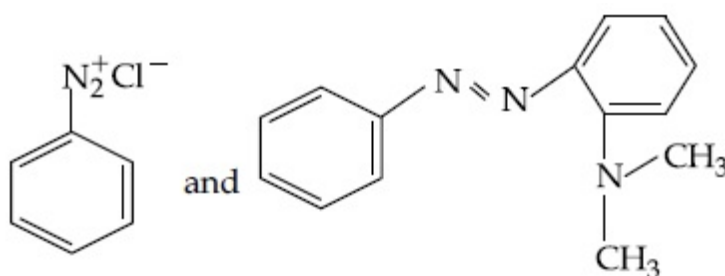

86435116085.

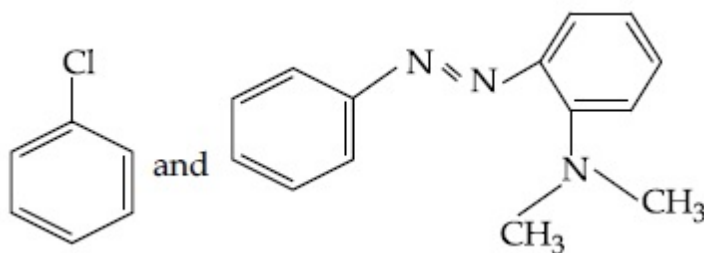

86435116086.

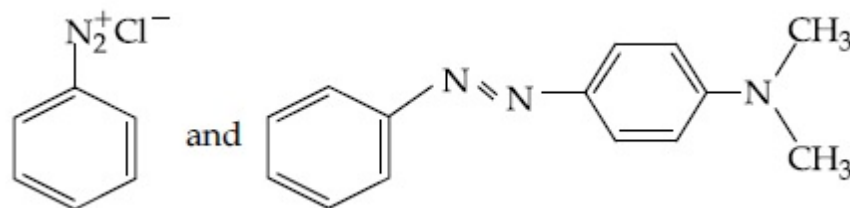

86435116087.

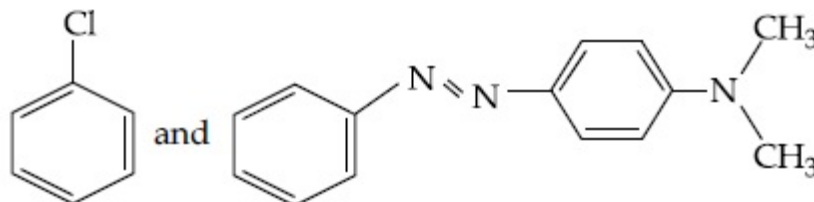

86435116088.

Question Number : 47 Question Id : 8643515357 Question Type : MCQ Option Shuffling : Yes Is Question Mandatory : No

Correct Marks : 4 Wrong Marks : 1

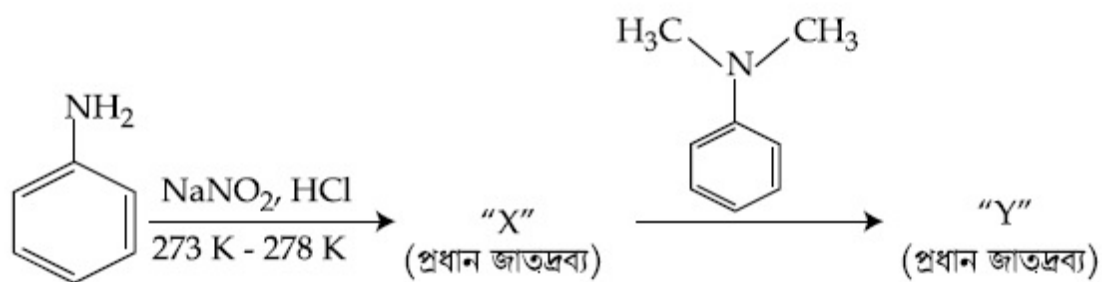

ওপৰৰ বিক্ৰিয়া অনুসৰি, X আৰু Y যথাক্ৰমে হ'ল :

Options :

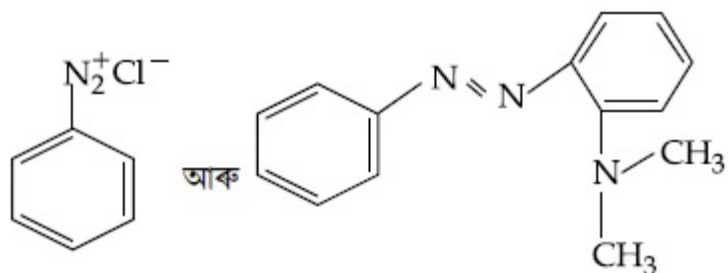

86435116085.

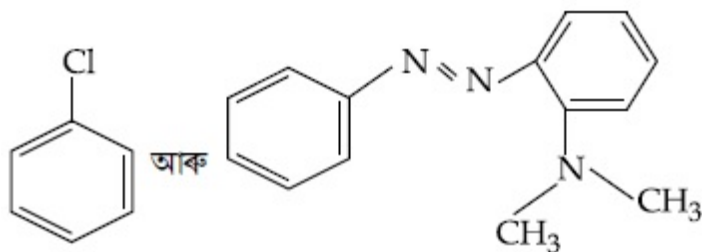

86435116086.

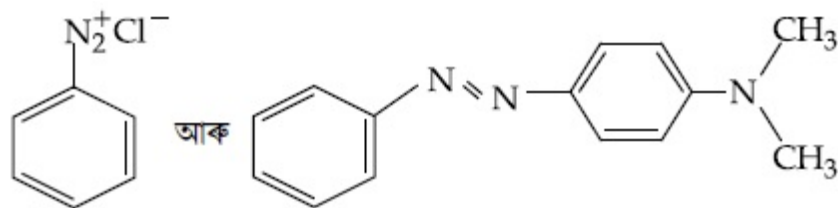

86435116087.

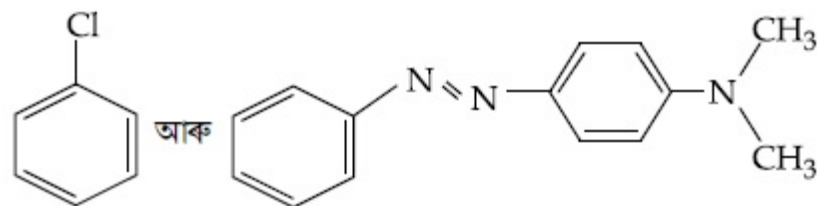

86435116088.

Question Number : 48 Question Id : 8643515358 Question Type : MCQ Option Shuffling : Yes Is

Question Mandatory : No

Correct Marks : 4 Wrong Marks : 1

Match List - I with List - II :

List - I (Class of Drug)	List - II (Example)
(a) Antacid	(i) Novestrol
(b) Artificial Sweetener	(ii) Cimetidine
(c) Antifertility	(iii) Valium
(d) Tranquilizers	(iv) Alitame

Choose the most appropriate match :

Options :

86435116089. (a)-(ii), (b)-(iv), (c)-(iii), (d)-(i)

86435116090. (a)-(ii), (b)-(iv), (c)-(i), (d)-(iii)

86435116091. (a)-(iv), (b)-(i), (c)-(ii), (d)-(iii)

86435116092. (a)-(iv), (b)-(iii), (c)-(i), (d)-(ii)

Question Number : 48 Question Id : 8643515358 Question Type : MCQ Option Shuffling : Yes Is Question Mandatory : No

Correct Marks : 4 Wrong Marks : 1

তালিকা - I ক তালিকা - II ৰ সৈতে মিলন কৰা :

তালিকা - I (ঔষধৰ শ্ৰেণী)	তালিকা - II (উদাহৰণ)
(a) এন্টাছিড	(i) নভে'ষ্ট্ৰল
(b) কৃত্ৰিম মিঠাকৰী	(ii) ছিমেটিডিন
(c) প্ৰজননতৰোধী	(iii) ভেলিয়াম
(d) সুস্থিৰকাৰী	(iv) এলিটেম

আটাইতকৈ উপযুক্ত মিলনটো বাছি উলিওৱা :

Options :

86435116089. (a)-(ii), (b)-(iv), (c)-(iii), (d)-(i)

86435116090. (a)-(ii), (b)-(iv), (c)-(i), (d)-(iii)

86435116091. (a)-(iv), (b)-(i), (c)-(ii), (d)-(iii)

86435116092. (a)-(iv), (b)-(iii), (c)-(i), (d)-(ii)

Question Number : 49 Question Id : 8643515359 Question Type : MCQ Option Shuffling : Yes Is Question Mandatory : No

Correct Marks : 4 Wrong Marks : 1

A non-reducing sugar "A" hydrolyses to give two reducing mono saccharides. Sugar A is :

Options :

86435116093. Glucose

86435116094. Fructose

86435116095. Galactose

86435116096. Sucrose

Question Number : 49 Question Id : 8643515359 Question Type : MCQ Option Shuffling : Yes Is Question Mandatory : No

Correct Marks : 4 Wrong Marks : 1

এটা অবিজাৰক শৰ্কৰা "A" এ জলবিশ্লেষণত দিয়ে দুটা জাৰক মন'ছেকাৰাইড। শৰ্কৰা A হ'ল :

Options :

86435116093. গ্লুক'জ

86435116094. ফ্ৰুক্ট'জ

86435116095. গেলেক্ট'জ

86435116096. ছুক্ৰ'জ

Question Number : 50 Question Id : 8643515360 Question Type : MCQ Option Shuffling : Yes Is Question Mandatory : No

Correct Marks : 4 Wrong Marks : 1

Reagent, 1-naphthylamine and sulphanilic acid in acetic acid is used for the detection of :

Options :

86435116097. NO_2^- 86435116098. NO_3^- 86435116099. NO 86435116100. N_2O

Question Number : 50 Question Id : 8643515360 Question Type : MCQ Option Shuffling : Yes Is Question Mandatory : No

Correct Marks : 4 Wrong Marks : 1

এছেটিক এছিডত বিকাৰক, 1-নেফথাইলএমাইন আৰু ছালফানিলিক এছিড ক ব্যৱহাৰ কৰা হয় চিনাক্তকৰণৰ বাবে :

Options :

86435116097. NO_2^- 86435116098. NO_3^- 86435116099. NO 86435116100. N_2O

Chemistry Section B

Section Id :	864351358
Section Number :	4
Section type :	Online
Mandatory or Optional :	Mandatory
Number of Questions :	10
Number of Questions to be attempted :	5
Section Marks :	20
Mark As Answered Required? :	Yes
Sub-Section Number :	1
Sub-Section Id :	864351358
Question Shuffling Allowed :	Yes

Question Number : 51 Question Id : 8643515361 Question Type : SA Correct Marks : 4 Wrong Marks : 0

Complete combustion of 3 g of ethane gives $x \times 10^{22}$ molecules of water. The value of x is _____ . (Round off to the Nearest Integer).

[Use : $N_A = 6.023 \times 10^{23}$; Atomic masses in u : C : 12.0 ; O : 16.0 ; H : 1.0]

Response Type : Numeric

Evaluation Required For SA : Yes

Show Word Count : Yes

Answers Type : Equal

Text Areas : PlainText

Possible Answers :

100

Question Number : 51 **Question Id :** 8643515361 **Question Type :** SA

Correct Marks : 4 **Wrong Marks :** 0

3 g ইথেনৰ সম্পূৰ্ণ দহনে দিয়ে $x \times 10^{22}$ পানীৰ অণু। x ৰ মান _____। (নিকটতম অখণ্ড সংখ্যাত)

[ব্যৱহাৰ কৰা : $N_A = 6.023 \times 10^{23}$; পৰমাণৱিক ভৰ u ত : C : 12.0 ; O : 16.0 ; H : 1.0]

Response Type : Numeric

Evaluation Required For SA : Yes

Show Word Count : Yes

Answers Type : Equal

Text Areas : PlainText

Possible Answers :

100

Question Number : 52 **Question Id :** 8643515362 **Question Type :** SA

Correct Marks : 4 **Wrong Marks :** 0

AX is a covalent diatomic molecule where A and X are second row elements of periodic table. Based on Molecular orbital theory, the bond order of AX is 2.5. The total number of electrons in AX is _____. (Round off to the Nearest Integer).

Response Type : Numeric

Evaluation Required For SA : Yes

Show Word Count : Yes

Answers Type : Equal

Text Areas : PlainText

Possible Answers :

100

Question Number : 52 **Question Id :** 8643515362 **Question Type :** SA

Correct Marks : 4 **Wrong Marks :** 0

AX এটা দ্বিপাৰমাণৱিক সহযোজী অণু য'ত A আৰু X হ'ল পৰ্যাবৃত্ত তালিকাৰ দ্বিতীয় শাৰীৰ মৌল। আণৱিক অৰবিটেল সূত্ৰৰ ওপৰত ভেটি কৰি, AX ৰ বান্ধনি ক্ৰম হ'ল 2.5। AX ত মুঠ ইলেকট্ৰনৰ সংখ্যা _____।
(নিকটতম অখণ্ড সংখ্যাত)

Response Type : Numeric

Evaluation Required For SA : Yes

Show Word Count : Yes

Answers Type : Equal

Text Areas : PlainText

Possible Answers :

100

Question Number : 53 **Question Id :** 8643515363 **Question Type :** SA

Correct Marks : 4 **Wrong Marks :** 0

For the reaction

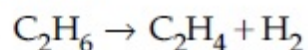

the reaction enthalpy $\Delta_r H =$ _____ kJ mol^{-1} . (Round off to the Nearest Integer).

[Given : Bond enthalpies in kJ mol^{-1} : C–C : 347, C=C : 611;

C–H : 414, H–H : 436]

Response Type : Numeric

Evaluation Required For SA : Yes

Show Word Count : Yes

Answers Type : Equal

Text Areas : PlainText

Possible Answers :

100

Question Number : 53 **Question Id :** 8643515363 **Question Type :** SA

Correct Marks : 4 **Wrong Marks :** 0

বিক্ৰিয়াটোৰ বাবে

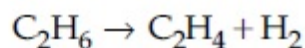

বিক্ৰিয়া এনথালপি $\Delta_r H =$ _____ kJ mol^{-1} । (নিকটতম অখণ্ড সংখ্যাত)

[দিয়া আছে : বান্ধনি এনথালপি kJ mol^{-1} ত : C–C : 347, C=C : 611;

C–H : 414, H–H : 436]

Response Type : Numeric

Evaluation Required For SA : Yes

Show Word Count : Yes

Answers Type : Equal

Text Areas : PlainText

Possible Answers :

100

Question Number : 54 Question Id : 8643515364 Question Type : SA

Correct Marks : 4 Wrong Marks : 0

2 molal solution of a weak acid HA has a freezing point of 3.885°C . The degree of dissociation of this acid is _____ $\times 10^{-3}$. (Round off to the Nearest Integer).

[Given : Molal depression constant of water = $1.85 \text{ K kg mol}^{-1}$

Freezing point of pure water = 0°C]

Response Type : Numeric

Evaluation Required For SA : Yes

Show Word Count : Yes

Answers Type : Equal

Text Areas : PlainText

Possible Answers :

100

Question Number : 54 Question Id : 8643515364 Question Type : SA

Correct Marks : 4 Wrong Marks : 0

এটা মৃদু এছিড HA ৰ 2 ম'লাল দ্ৰৱৰ হিমাংক বিন্দু 3.885°C । এছিডটোৰ বিয়োজন মাত্ৰা _____ $\times 10^{-3}$ ।
(নিকটতম অখণ্ড সংখ্যাত)

[দিয়া আছে : পানীৰ ম'লাল অৱনমন ধ্ৰুৱক = $1.85 \text{ K kg mol}^{-1}$

বিশুদ্ধ পানীৰ হিমাংক বিন্দু = 0°C]

Response Type : Numeric

Evaluation Required For SA : Yes

Show Word Count : Yes

Answers Type : Equal

Text Areas : PlainText

Possible Answers :

100

Question Number : 55 Question Id : 8643515365 Question Type : SA

Correct Marks : 4 Wrong Marks : 0

In order to prepare a buffer solution of pH 5.74, sodium acetate is added to acetic acid. If the concentration of acetic acid in the buffer is 1.0 M, the concentration of sodium acetate in the buffer is _____ M. (Round off to the Nearest Integer).

[Given : pKa (acetic acid) = 4.74]

Response Type : Numeric**Evaluation Required For SA :** Yes**Show Word Count :** Yes**Answers Type :** Equal**Text Areas :** PlainText**Possible Answers :**

100

Question Number : 55 Question Id : 8643515365 Question Type : SA**Correct Marks : 4 Wrong Marks : 0**

এটা pH 5.74 ৰ বাফাৰ দ্ৰৱ বনোৱাৰ বাবে, এছেটিক এছিডত ছ'ডিয়াম এছিটেট যোগ কৰা হয়। যদি এছেটিক এছিডৰ বাফাৰত গাঢ়তা 1.0 M , ছ'ডিয়াম এছিটেটৰ বাফাৰত গাঢ়তা হ'ব _____ M। (নিকটতম অখণ্ড সংখ্যাত)

[দিয়া আছে : pKa (এছেটিক এছিড) = 4.74]

Response Type : Numeric**Evaluation Required For SA :** Yes**Show Word Count :** Yes**Answers Type :** Equal**Text Areas :** PlainText**Possible Answers :**

100

Question Number : 56 Question Id : 8643515366 Question Type : SA**Correct Marks : 4 Wrong Marks : 0**

For the reaction

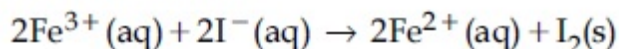

the magnitude of the standard molar free energy change,

$$\Delta_r G_m^\circ = - \text{_____ kJ (Round off to the Nearest Integer).}$$

$$\left[\begin{array}{l} E^\circ_{\text{Fe}^{2+}/\text{Fe}(\text{s})} = -0.440 \text{ V}; E^\circ_{\text{Fe}^{3+}/\text{Fe}(\text{s})} = -0.036 \text{ V} \\ E^\circ_{\text{I}_2/2\text{I}^{-}} = 0.539 \text{ V}; \quad F = 96500 \text{ C} \end{array} \right]$$

Response Type : Numeric**Evaluation Required For SA :** Yes**Show Word Count :** Yes**Answers Type :** Equal**Text Areas :** PlainText**Possible Answers :**

100

Question Number : 56 Question Id : 8643515366 Question Type : SA

Correct Marks : 4 Wrong Marks : 0

বিক্রিয়াটোৰ বাবে

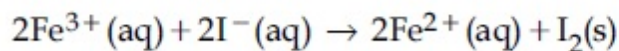

প্ৰমাণ ম'লাৰ মুক্ত শক্তি পৰিবৰ্তনৰ মান,

$$\Delta_r G_m^\circ = - \text{_____ kJ l (নিকটতম অখণ্ড সংখ্যাত)}$$

$$\left[\begin{array}{l} E^\circ_{\text{Fe}^{2+}/\text{Fe}(\text{s})} = -0.440 \text{ V}; E^\circ_{\text{Fe}^{3+}/\text{Fe}(\text{s})} = -0.036 \text{ V} \\ E^\circ_{\text{I}_2/2\text{I}^{-}} = 0.539 \text{ V}; F = 96500 \text{ C} \end{array} \right]$$

Response Type : Numeric

Evaluation Required For SA : Yes

Show Word Count : Yes

Answers Type : Equal

Text Areas : PlainText

Possible Answers :

100

Question Number : 57 Question Id : 8643515367 Question Type : SA

Correct Marks : 4 Wrong Marks : 0

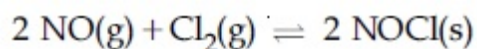

This reaction was studied at -10°C and the following data was obtained

run	$[\text{NO}]_0$	$[\text{Cl}_2]_0$	r_0
1	0.10	0.10	0.18
2	0.10	0.20	0.35
3	0.20	0.20	1.40

$[\text{NO}]_0$ and $[\text{Cl}_2]_0$ are the initial concentrations and r_0 is the initial reaction rate.

The overall order of the reaction is _____. (Round off to the Nearest Integer).

Response Type : Numeric

Evaluation Required For SA : Yes

Show Word Count : Yes

Answers Type : Equal

Text Areas : PlainText

Possible Answers :

100

Question Number : 57 Question Id : 8643515367 Question Type : SA

Correct Marks : 4 Wrong Marks : 0

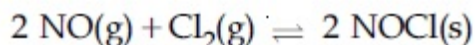

এই বিক্রিয়াটো -10°C ত অধ্যয়ন কৰা হৈছিল আৰু তলত দিয়া তথ্যসমূহ পোৱা গৈছিল :

দৌৰ	$[\text{NO}]_0$	$[\text{Cl}_2]_0$	r_0
1	0.10	0.10	0.18
2	0.10	0.20	0.35
3	0.20	0.20	1.40

$[\text{NO}]_0$ আৰু $[\text{Cl}_2]_0$ হ'ল প্ৰাৰম্ভিক গাঢ়তা আৰু r_0 হ'ল আৰম্ভণি বিক্রিয়াৰ বেগ। বিক্রিয়াটোৰ মুঠ ক্ৰম হ'ল _____।

(নিকটতম অখণ্ড সংখ্যাত)

Response Type : Numeric

Evaluation Required For SA : Yes

Show Word Count : Yes

Answers Type : Equal

Text Areas : PlainText

Possible Answers :

100

Question Number : 58 Question Id : 8643515368 Question Type : SA

Correct Marks : 4 Wrong Marks : 0

The total number of unpaired electrons present in the complex $\text{K}_3[\text{Cr}(\text{oxalate})_3]$ is _____.

Response Type : Numeric

Evaluation Required For SA : Yes

Show Word Count : Yes

Answers Type : Equal

Text Areas : PlainText

Possible Answers :

100

Question Number : 58 Question Id : 8643515368 Question Type : SA

Correct Marks : 4 Wrong Marks : 0

জটিল $\text{K}_3[\text{Cr}(\text{oxalate})_3]$ ত উপস্থিত থকা মুঠ অযুগ্ম ইলেকট্ৰনৰ সংখ্যা _____।

Response Type : Numeric

Evaluation Required For SA : Yes

Show Word Count : Yes

Answers Type : Equal

Text Areas : PlainText

Possible Answers :

100

Question Number : 59 Question Id : 8643515369 Question Type : SA

Correct Marks : 4 Wrong Marks : 0

_____ grams of 3-Hydroxy propanal (MW = 74) must be dehydrated to produce 7.8 g of acrolein (MW = 56) (C_3H_4O) if the percentage yield is 64. (Round off to the Nearest Integer).

[Given : Atomic masses : C : 12.0 u, H : 1.0 u, O : 16.0 u]

Response Type : Numeric

Evaluation Required For SA : Yes

Show Word Count : Yes

Answers Type : Equal

Text Areas : PlainText

Possible Answers :

100

Question Number : 59 Question Id : 8643515369 Question Type : SA

Correct Marks : 4 Wrong Marks : 0

_____ গ্রাম 3-হাইড্রক্সি প্রপানেল (MW = 74) ব নিজলীকরণ কৰিব লাগিব 7.8 g এক্ৰ'লিন (C_3H_4O) (MW = 56) উৎপন্ন কৰিবলৈ, যদি শতকৰা উৎপাদন হয় 64। (নিকটতম অখণ্ড সংখ্যাত)

[দিয়া আছে : পৰমাণৱিক ভৰ : C : 12.0 u, H : 1.0 u, O : 16.0 u]

Response Type : Numeric

Evaluation Required For SA : Yes

Show Word Count : Yes

Answers Type : Equal

Text Areas : PlainText

Possible Answers :

100

Question Number : 60 Question Id : 8643515370 Question Type : SA

Correct Marks : 4 Wrong Marks : 0

A reaction of 0.1 mole of Benzylamine with bromomethane gave 23 g of Benzyl trimethyl ammonium bromide. The number of moles of bromomethane consumed in this reaction are $n \times 10^{-1}$, when $n =$ _____. (Round off to the Nearest Integer).

[Given : Atomic masses : C : 12.0 u, H : 1.0 u, N : 14.0 u, Br : 80.0 u]

Response Type : Numeric

Evaluation Required For SA : Yes

Show Word Count : Yes

Answers Type : Equal

Text Areas : PlainText

Possible Answers :

100

Question Number : 60 Question Id : 8643515370 Question Type : SA**Correct Marks : 4 Wrong Marks : 0**

0.1 ম'ল বেনযিলএমাইনৰ ব্র'ম'মিথেনৰ লগত বিক্রিয়াত দিয়ে 23 g বেনযিল ট্ৰাইমিঠাইল এম'নিয়াম ব্র'মাইড। বিক্রিয়াটোত
 প্রযুক্ত হোৱা ব্র'ম'মিথেনৰ ম'লৰ সংখ্যা $n \times 10^{-1}$, যেতিয়া $n =$ _____ (নিকটতম অখণ্ড সংখ্যাত)

[দিয়া আছে : পারমাণৱিক ভৰ : C : 12.0 u, H : 1.0 u, N : 14.0 u, Br : 80.0 u]

Response Type : Numeric**Evaluation Required For SA : Yes****Show Word Count : Yes****Answers Type : Equal****Text Areas : PlainText****Possible Answers :**

100

Mathematics Section A

Section Id :	864351359
Section Number :	5
Section type :	Online
Mandatory or Optional :	Mandatory
Number of Questions :	20
Number of Questions to be attempted :	20
Section Marks :	80
Mark As Answered Required? :	Yes
Sub-Section Number :	1
Sub-Section Id :	864351359
Question Shuffling Allowed :	Yes

Question Number : 61 Question Id : 8643515371 Question Type : MCQ Option Shuffling : Yes Is**Question Mandatory : No****Correct Marks : 4 Wrong Marks : 1**

If the functions are defined as $f(x) = \sqrt{x}$ and $g(x) = \sqrt{1-x}$, then what is the common domain of the following functions : $f+g$, $f-g$, f/g , g/f , $g-f$ where

$$(f \pm g)(x) = f(x) \pm g(x), (f/g)(x) = \frac{f(x)}{g(x)}$$

Options :86435116111. $0 \leq x < 1$

86435116112. $0 < x < 1$

86435116113. $0 \leq x \leq 1$

86435116114. $0 < x \leq 1$

Question Number : 61 Question Id : 8643515371 Question Type : MCQ Option Shuffling : Yes Is Question Mandatory : No

Correct Marks : 4 Wrong Marks : 1

যদি $f(x) = \sqrt{x}$ আৰু $g(x) = \sqrt{1-x}$, ফলন দুটা সংজ্ঞাবদ্ধ/বৰ্ণিত আছে। তেন্তে $f+g, f-g, f/g, g/f, g-f$ যত

$$(f \pm g)(x) = f(x) \pm g(x), (f/g)(x) = \frac{f(x)}{g(x)}$$

ফলনবোৰৰ সাধাৰণ আদিক্ষেত্র হ'ব :

Options :

86435116111. $0 \leq x < 1$

86435116112. $0 < x < 1$

86435116113. $0 \leq x \leq 1$

86435116114. $0 < x \leq 1$

Question Number : 62 Question Id : 8643515372 Question Type : MCQ Option Shuffling : Yes Is Question Mandatory : No

Correct Marks : 4 Wrong Marks : 1

If the equation $a|z|^2 + \overline{\alpha}z + \alpha\overline{z} + d = 0$ represents a circle where a, d are real constants, then which of the following condition is correct ?

Options :

86435116115. $|\alpha|^2 - ad \geq 0$ and $a \in \mathbb{R}$

86435116116. $|\alpha|^2 - ad > 0$ and $a \in \mathbb{R} - \{0\}$

86435116117. $|\alpha|^2 - ad \neq 0$

86435116118. $\alpha = 0, a, d \in \mathbb{R}^+$

Question Number : 62 Question Id : 8643515372 Question Type : MCQ Option Shuffling : Yes Is Question Mandatory : No Correct Marks : 4 Wrong Marks : 1

যদি $a|z|^2 + \overline{\alpha}z + \alpha\overline{z} + d = 0$ সমীকরণটোৱে এটা বৃত্তক বুজায়, যত a, d বাস্তৱ ধ্ৰুৱক। তেন্তে তলৰ কোনটো চৰ্ত

শুদ্ধ :

Options :

86435116115. $|\alpha|^2 - ad \geq 0$ আৰু $a \in \mathbb{R}$

86435116116. $|\alpha|^2 - ad > 0$ আৰু $a \in \mathbb{R} - \{0\}$

86435116117. $|\alpha|^2 - ad \neq 0$

86435116118. $\alpha = 0, a, d \in \mathbb{R}^+$

Question Number : 63 Question Id : 8643515373 Question Type : MCQ Option Shuffling : Yes Is Question Mandatory : No Correct Marks : 4 Wrong Marks : 1

Let $A + 2B = \begin{bmatrix} 1 & 2 & 0 \\ 6 & -3 & 3 \\ -5 & 3 & 1 \end{bmatrix}$ and $2A - B = \begin{bmatrix} 2 & -1 & 5 \\ 2 & -1 & 6 \\ 0 & 1 & 2 \end{bmatrix}$. If $\text{Tr}(A)$ denotes the sum of all

diagonal elements of the matrix A , then $\text{Tr}(A) - \text{Tr}(B)$ has value equal to :

Options :

86435116119. 1

86435116120. 2

86435116121. 3

86435116122. 0

Question Number : 63 Question Id : 8643515373 Question Type : MCQ Option Shuffling : Yes Is Question Mandatory : No Correct Marks : 4 Wrong Marks : 1

ধৰা হ'ল $A + 2B = \begin{bmatrix} 1 & 2 & 0 \\ 6 & -3 & 3 \\ -5 & 3 & 1 \end{bmatrix}$ আৰু $2A - B = \begin{bmatrix} 2 & -1 & 5 \\ 2 & -1 & 6 \\ 0 & 1 & 2 \end{bmatrix}$. যদি $\text{Tr}(A)$ য়ে A মৌলকক্ষৰ আটাইবোৰ

বিকৰ্ণমৌলৰ যোগফল বুজায়, তেন্তে $\text{Tr}(A) - \text{Tr}(B)$ মান সমান হ'ব :

Options :

86435116119. 1

86435116120. 2

86435116121. 3

86435116122. 0

Question Number : 64 Question Id : 8643515374 Question Type : MCQ Option Shuffling : Yes Is

Question Mandatory : No

Correct Marks : 4 Wrong Marks : 1

Let α, β, γ be the real roots of the equation, $x^3 + ax^2 + bx + c = 0$, ($a, b, c \in \mathbb{R}$ and $a, b \neq 0$). If the system of equations (in u, v, w) given by $\alpha u + \beta v + \gamma w = 0$; $\beta u + \gamma v + \alpha w = 0$;

$\gamma u + \alpha v + \beta w = 0$ has non-trivial solution, then the value of $\frac{a^2}{b}$ is :

Options :

86435116123. 0

86435116124. 1

86435116125. 3

86435116126. 5

Question Number : 64 Question Id : 8643515374 Question Type : MCQ Option Shuffling : Yes Is

Question Mandatory : No

Correct Marks : 4 Wrong Marks : 1

ধৰা হ'ল $x^3 + ax^2 + bx + c = 0$, ($a, b, c \in \mathbf{R}$ আৰু $a, b \neq 0$) সমীকৰণটোৰ তিনিটা বাস্তৱ মূল α, β, γ । যদি $\alpha u + \beta v + \gamma w = 0$; $\beta u + \gamma v + \alpha w = 0$; $\gamma u + \alpha v + \beta w = 0$ সমীকৰণ প্ৰণালীবোৰৰ (u, v, w) ত অশূন্য সমাধান

আছে, তেন্তে $\frac{a^2}{b}$ ৰ মান হ'ব :

Options :

86435116123. 0

86435116124. 1

86435116125. 3

86435116126. 5

Question Number : 65 Question Id : 8643515375 Question Type : MCQ Option Shuffling : Yes Is Question Mandatory : No

Correct Marks : 4 Wrong Marks : 1

The sum of all the 4-digit distinct numbers that can be formed with the digits 1, 2, 2 and 3 is :

Options :

86435116127. 22264

86435116128. 26664

86435116129. 122234

86435116130. 122664

Question Number : 65 Question Id : 8643515375 Question Type : MCQ Option Shuffling : Yes Is Question Mandatory : No

Correct Marks : 4 Wrong Marks : 1

1, 2, 2 আৰু 3 অংকৰে গঠিত কৰিব পৰা 4 অংকীয়া ভিন্ন সংখ্যাৰ যোগফল হ'ব :

Options :

86435116127. 22264

86435116128. 26664

86435116129. 122234

86435116130. 122664

Question Number : 66 Question Id : 8643515376 Question Type : MCQ Option Shuffling : Yes Is Question Mandatory : No

Correct Marks : 4 Wrong Marks : 1

Let $(1 + x + 2x^2)^{20} = a_0 + a_1x + a_2x^2 + \dots + a_{40}x^{40}$. Then, $a_1 + a_3 + a_5 + \dots + a_{37}$ is equal to :

Options :

86435116131. $2^{19}(2^{20} + 21)$ 86435116132. $2^{20}(2^{20} + 21)$ 86435116133. $2^{19}(2^{20} - 21)$ 86435116134. $2^{20}(2^{20} - 21)$

Question Number : 66 Question Id : 8643515376 Question Type : MCQ Option Shuffling : Yes Is Question Mandatory : No

Correct Marks : 4 Wrong Marks : 1

ধরা হ'ল $(1 + x + 2x^2)^{20} = a_0 + a_1x + a_2x^2 + \dots + a_{40}x^{40}$ । তেস্তে $a_1 + a_3 + a_5 + \dots + a_{37}$ সমান হ'ব :

Options :

86435116131. $2^{19}(2^{20} + 21)$ 86435116132. $2^{20}(2^{20} + 21)$ 86435116133. $2^{19}(2^{20} - 21)$ 86435116134. $2^{20}(2^{20} - 21)$

Question Number : 67 Question Id : 8643515377 Question Type : MCQ Option Shuffling : Yes Is Question Mandatory : No

Correct Marks : 4 Wrong Marks : 1

The value of $3 + \frac{1}{4 + \frac{1}{3 + \frac{1}{4 + \frac{1}{3 + \dots \infty}}}}$ is equal to :

Options :

86435116135. $1.5 + \sqrt{3}$

86435116136. $2 + \sqrt{3}$

86435116137. $3 + 2\sqrt{3}$

86435116138. $4 + \sqrt{3}$

Question Number : 67 Question Id : 8643515377 Question Type : MCQ Option Shuffling : Yes Is Question Mandatory : No

Correct Marks : 4 Wrong Marks : 1

$3 + \frac{1}{4 + \frac{1}{3 + \frac{1}{4 + \frac{1}{3 + \dots \infty}}}}$ ব মান সমান হ'ব :

Options :

86435116135. $1.5 + \sqrt{3}$

86435116136. $2 + \sqrt{3}$

86435116137. $3 + 2\sqrt{3}$

86435116138. $4 + \sqrt{3}$

Question Number : 68 Question Id : 8643515378 Question Type : MCQ Option Shuffling : Yes Is Question Mandatory : No

Correct Marks : 4 Wrong Marks : 1

$\frac{1}{3^2 - 1} + \frac{1}{5^2 - 1} + \frac{1}{7^2 - 1} + \dots + \frac{1}{(201)^2 - 1}$ is equal to :

Options :

$$86435116139. \frac{25}{101}$$

$$86435116140. \frac{101}{408}$$

$$86435116141. \frac{99}{400}$$

$$86435116142. \frac{101}{404}$$

Question Number : 68 Question Id : 8643515378 Question Type : MCQ Option Shuffling : Yes Is Question Mandatory : No

Correct Marks : 4 Wrong Marks : 1

$$\frac{1}{3^2 - 1} + \frac{1}{5^2 - 1} + \frac{1}{7^2 - 1} + \dots + \frac{1}{(201)^2 - 1} \text{ समान ह'व :}$$

Options :

$$86435116139. \frac{25}{101}$$

$$86435116140. \frac{101}{408}$$

$$86435116141. \frac{99}{400}$$

$$86435116142. \frac{101}{404}$$

Question Number : 69 Question Id : 8643515379 Question Type : MCQ Option Shuffling : Yes Is Question Mandatory : No

Correct Marks : 4 Wrong Marks : 1

If α, β are natural numbers such that $100^\alpha - 199^\beta = (100)(100) + (99)(101) + (98)(102) + \dots + (1)(199)$, then the slope of the line passing through (α, β) and origin is :

Options :

86435116143. 510

86435116144. 530

86435116145. 540

86435116146. 550

Question Number : 69 Question Id : 8643515379 Question Type : MCQ Option Shuffling : Yes Is Question Mandatory : No

Correct Marks : 4 Wrong Marks : 1

যদি α আৰু β স্বাভাৱিক সংখ্যা যাতে $100^\alpha - 199^\beta = (100)(100) + (99)(101) + (98)(102) + \dots + (1)(199)$, হয়, তেন্তে মূলবিন্দু আৰু (α, β) বিন্দুৰে যোৱা ৰেখাৰ প্ৰৱণতা হ'ব :

Options :

86435116143. 510

86435116144. 530

86435116145. 540

86435116146. 550

Question Number : 70 Question Id : 8643515380 Question Type : MCQ Option Shuffling : Yes Is Question Mandatory : No

Correct Marks : 4 Wrong Marks : 1

If $f(x) = \begin{cases} \frac{1}{|x|} & ; |x| \geq 1 \\ ax^2 + b & ; |x| < 1 \end{cases}$ is differentiable at every point of the domain, then the values of

a and b are respectively :

Options :

86435116147. $\frac{1}{2}, \frac{1}{2}$ 86435116148. $-\frac{1}{2}, \frac{3}{2}$

86435116149. $\frac{5}{2}, -\frac{3}{2}$

86435116150. $\frac{1}{2}, -\frac{3}{2}$

Question Number : 70 Question Id : 8643515380 Question Type : MCQ Option Shuffling : Yes Is Question Mandatory : No

Correct Marks : 4 Wrong Marks : 1

যদি $f(x) = \begin{cases} \frac{1}{|x|} & ; |x| \geq 1 \\ ax^2 + b & ; |x| < 1 \end{cases}$ ফলনটো আদিম্বেত্রৰ প্ৰতিটো বিন্দুত অবিচ্ছিন্ন আৰু অৱকলনীয় হয় তেন্তে a আৰু

b ৰ মান হ'ব ক্ৰমে :

Options :

86435116147. $\frac{1}{2}, \frac{1}{2}$

86435116148. $-\frac{1}{2}, \frac{3}{2}$

86435116149. $\frac{5}{2}, -\frac{3}{2}$

86435116150. $\frac{1}{2}, -\frac{3}{2}$

Question Number : 71 Question Id : 8643515381 Question Type : MCQ Option Shuffling : Yes Is Question Mandatory : No

Correct Marks : 4 Wrong Marks : 1

The real valued function $f(x) = \frac{\operatorname{cosec}^{-1}x}{\sqrt{x - [x]}}$, where $[x]$ denotes the greatest integer less than or

equal to x , is defined for all x belonging to :

Options :

86435116151. all reals except integers

86435116152. all reals except the interval $[-1, 1]$

86435116153. all non-integers except the interval $[-1, 1]$

86435116154. all integers except 0, $-1, 1$

Question Number : 71 Question Id : 8643515381 Question Type : MCQ Option Shuffling : Yes Is Question Mandatory : No

Correct Marks : 4 Wrong Marks : 1

x ৰ সকলো মানৰ বাবে $f(x) = \frac{\operatorname{cosec}^{-1} x}{\sqrt{x - [x]}}$ ফলনটো সংজ্ঞাবদ্ধ, যত $[x]$ য়ে x ৰ সমান বা x তকৈ গৰিষ্ঠ অখণ্ড সংখ্যা

বুজায় :

Options :

86435116151. অখণ্ডৰ বাহিৰে সকলো বাস্তৱ

86435116152. $[-1, 1]$ অন্তৰালৰ বাহিৰে সকলো বাস্তৱ

86435116153. $[-1, 1]$ অন্তৰালৰ বাহিৰে সকলো অখণ্ড নহয়

86435116154. $0, -1, 1$ ৰ বাহিৰে সকলো অখণ্ড

Question Number : 72 Question Id : 8643515382 Question Type : MCQ Option Shuffling : Yes Is Question Mandatory : No

Correct Marks : 4 Wrong Marks : 1

If $\lim_{x \rightarrow 0} \frac{\sin^{-1} x - \tan^{-1} x}{3x^3}$ is equal to L , then the value of $(6L + 1)$ is :

Options :

86435116155. $\frac{1}{6}$

86435116156. 6

86435116157. 2

$$86435116158. \quad \frac{1}{2}$$

Question Number : 72 Question Id : 8643515382 Question Type : MCQ Option Shuffling : Yes Is Question Mandatory : No

Correct Marks : 4 Wrong Marks : 1

যদি $\lim_{x \rightarrow 0} \frac{\sin^{-1} x - \tan^{-1} x}{3x^3}$ সমান L হয়, তেন্তে $(6L + 1)$ ৰ মান হ'ব :

Options :

$$86435116155. \quad \frac{1}{6}$$

$$86435116156. \quad 6$$

$$86435116157. \quad 2$$

$$86435116158. \quad \frac{1}{2}$$

Question Number : 73 Question Id : 8643515383 Question Type : MCQ Option Shuffling : Yes Is Question Mandatory : No

Correct Marks : 4 Wrong Marks : 1

The integral $\int \frac{(2x - 1) \cos \sqrt{(2x - 1)^2 + 5}}{\sqrt{4x^2 - 4x + 6}} dx$ is equal to :

(where c is a constant of integration)

Options :

$$86435116159. \quad \frac{1}{2} \sin \sqrt{(2x + 1)^2 + 5} + c$$

$$86435116160. \quad \frac{1}{2} \sin \sqrt{(2x - 1)^2 + 5} + c$$

$$86435116161. \quad \frac{1}{2} \cos \sqrt{(2x - 1)^2 + 5} + c$$

86435116162. $\frac{1}{2} \cos \sqrt{(2x+1)^2 + 5} + c$

Question Number : 73 Question Id : 8643515383 Question Type : MCQ Option Shuffling : Yes Is Question Mandatory : No

Correct Marks : 4 Wrong Marks : 1

$\int \frac{(2x-1) \cos \sqrt{(2x-1)^2 + 5}}{\sqrt{4x^2 - 4x + 6}} dx$ অনুকলনটো সমান হ'ব :

(যত c অনুকলনৰ ধ্রুবক)

Options :

86435116159. $\frac{1}{2} \sin \sqrt{(2x+1)^2 + 5} + c$

86435116160. $\frac{1}{2} \sin \sqrt{(2x-1)^2 + 5} + c$

86435116161. $\frac{1}{2} \cos \sqrt{(2x-1)^2 + 5} + c$

86435116162. $\frac{1}{2} \cos \sqrt{(2x+1)^2 + 5} + c$

Question Number : 74 Question Id : 8643515384 Question Type : MCQ Option Shuffling : Yes Is Question Mandatory : No

Correct Marks : 4 Wrong Marks : 1

The differential equation satisfied by the system of parabolas $y^2 = 4a(x+a)$ is :

Options :

86435116163. $y \left(\frac{dy}{dx} \right)^2 + 2x \left(\frac{dy}{dx} \right) - y = 0$

86435116164. $y \left(\frac{dy}{dx} \right) + 2x \left(\frac{dy}{dx} \right) - y = 0$

86435116165. $y \left(\frac{dy}{dx} \right)^2 - 2x \left(\frac{dy}{dx} \right) + y = 0$

86435116166. $y\left(\frac{dy}{dx}\right)^2 - 2x\left(\frac{dy}{dx}\right) - y = 0$

Question Number : 74 Question Id : 8643515384 Question Type : MCQ Option Shuffling : Yes Is Question Mandatory : No

Correct Marks : 4 Wrong Marks : 1

$y^2 = 4a(x + a)$ অধিবৃত্ত প্রণালীর দ্বারা সিদ্ধ হোৱা অৱকলন সমীকৰণটো হ'ব :

Options :

86435116163. $y\left(\frac{dy}{dx}\right)^2 + 2x\left(\frac{dy}{dx}\right) - y = 0$

86435116164. $y\left(\frac{dy}{dx}\right) + 2x\left(\frac{dy}{dx}\right) - y = 0$

86435116165. $y\left(\frac{dy}{dx}\right)^2 - 2x\left(\frac{dy}{dx}\right) + y = 0$

86435116166. $y\left(\frac{dy}{dx}\right)^2 - 2x\left(\frac{dy}{dx}\right) - y = 0$

Question Number : 75 Question Id : 8643515385 Question Type : MCQ Option Shuffling : Yes Is Question Mandatory : No

Correct Marks : 4 Wrong Marks : 1

Choose the correct statement about two circles whose equations are given below :

$$x^2 + y^2 - 10x - 10y + 41 = 0$$

$$x^2 + y^2 - 22x - 10y + 137 = 0$$

Options :

86435116167. circles have two meeting points

86435116168. circles have no meeting point

86435116169. circles have only one meeting point

86435116170. circles have same centre

Question Number : 75 Question Id : 8643515385 Question Type : MCQ Option Shuffling : Yes Is Question Mandatory : No

Correct Marks : 4 Wrong Marks : 1

নিম্ন প্রদত্ত

$$x^2 + y^2 - 10x - 10y + 41 = 0$$

$$x^2 + y^2 - 22x - 10y + 137 = 0$$

বৃত্ত দুটাৰ সম্পৰ্কে শুদ্ধ উক্তিটো বাছনি কৰা :

Options :

86435116167. বৃত্ত দুটাৰ দুটা ছেদবিন্দু আছে।

86435116168. বৃত্ত দুটাৰ কোনো ছেদবিন্দু নাই।

86435116169. বৃত্ত দুটাৰ এটা ছেদবিন্দু আছে।

86435116170. বৃত্ত দুটাৰ একে কেন্দ্ৰ আছে।

Question Number : 76 Question Id : 8643515386 Question Type : MCQ Option Shuffling : Yes Is Question Mandatory : No

Correct Marks : 4 Wrong Marks : 1

For the four circles M, N, O and P, following four equations are given :

Circle M : $x^2 + y^2 = 1$

Circle N : $x^2 + y^2 - 2x = 0$

Circle O : $x^2 + y^2 - 2x - 2y + 1 = 0$

Circle P : $x^2 + y^2 - 2y = 0$

If the centre of circle M is joined with centre of the circle N, further centre of circle N is joined with centre of the circle O, centre of circle O is joined with the centre of circle P and lastly, centre of circle P is joined with centre of circle M, then these lines form the sides of a :

Options :

86435116171. Rectangle

86435116172. Rhombus

86435116173. Square

86435116174. Parallelogram

Question Number : 76 Question Id : 8643515386 Question Type : MCQ Option Shuffling : Yes Is Question Mandatory : No

Correct Marks : 4 Wrong Marks : 1

M, N, O আৰু P বৃত্ত চাৰিটাৰ বাবে চাৰিটা সমীকৰণ দিয়া আছে :

$$M \text{ বৃত্ত : } x^2 + y^2 = 1$$

$$N \text{ বৃত্ত : } x^2 + y^2 - 2x = 0$$

$$O \text{ বৃত্ত : } x^2 + y^2 - 2x - 2y + 1 = 0$$

$$P \text{ বৃত্ত : } x^2 + y^2 - 2y = 0$$

যদি M বৃত্তৰ কেন্দ্ৰৰ সৈতে N বৃত্তৰ কেন্দ্ৰ সংযোগ কৰা হয়, N বৃত্তৰ কেন্দ্ৰৰ সৈতে O বৃত্তৰ কেন্দ্ৰ সংযোগ কৰা হয়, O বৃত্তৰ কেন্দ্ৰৰ সৈতে P বৃত্তৰ কেন্দ্ৰ সংযোগ কৰা হয় আৰু P বৃত্তৰ কেন্দ্ৰৰ সৈতে M বৃত্তৰ কেন্দ্ৰ সংযোগ কৰা হয় তেন্তে এই ৰেখাবোৰে বাহুবোৰ গঠন কৰিব :

Options :

86435116171. আয়তৰ

86435116172. বম্বাছৰ

86435116173. বৰ্গৰ

86435116174. সামান্তৰিকৰ

Question Number : 77 Question Id : 8643515387 Question Type : MCQ Option Shuffling : Yes Is Question Mandatory : No

Correct Marks : 4 Wrong Marks : 1

The number of integral values of m so that the abscissa of point of intersection of lines $3x + 4y = 9$ and $y = mx + 1$ is also an integer, is :

Options :

86435116175. 0

86435116176. 1

86435116177. 2

86435116178. 3

Question Number : 77 Question Id : 8643515387 Question Type : MCQ Option Shuffling : Yes Is Question Mandatory : No

Correct Marks : 4 Wrong Marks : 1

m ব অখণ্ড মানৰ সংখ্যা হ'ব যাতে $3x + 4y = 9$ আৰু $y = mx + 1$ ৰেখাদুডালৰ ছেদবিন্দুৰ ভূজটো এটা অখণ্ড সংখ্যা হয় :

Options :

86435116175. 0

86435116176. 1

86435116177. 2

86435116178. 3

Question Number : 78 Question Id : 8643515388 Question Type : MCQ Option Shuffling : Yes Is Question Mandatory : No

Correct Marks : 4 Wrong Marks : 1

The equation of one of the straight lines which passes through the point (1, 3) and makes an angle $\tan^{-1}(\sqrt{2})$ with the straight line, $y + 1 = 3\sqrt{2}x$ is :

Options :

86435116179. $4\sqrt{2}x + 5y - (15 + 4\sqrt{2}) = 0$ 86435116180. $4\sqrt{2}x - 5y - (5 + 4\sqrt{2}) = 0$ 86435116181. $5\sqrt{2}x + 4y - (15 + 4\sqrt{2}) = 0$ 86435116182. $4\sqrt{2}x + 5y - 4\sqrt{2} = 0$

Question Number : 78 Question Id : 8643515388 Question Type : MCQ Option Shuffling : Yes Is Question Mandatory : No

Correct Marks : 4 Wrong Marks : 1

(1, 3) বিন্দুতে যোরা আৰু $y + 1 = 3\sqrt{2}x$ ৰেখাৰ সৈতে $\tan^{-1}(\sqrt{2})$ কোণ কৰা কোনো এটা ৰেখাৰ সমীকৰণ হ'ব :

Options :

86435116179. $4\sqrt{2}x + 5y - (15 + 4\sqrt{2}) = 0$

86435116180. $4\sqrt{2}x - 5y - (5 + 4\sqrt{2}) = 0$

86435116181. $5\sqrt{2}x + 4y - (15 + 4\sqrt{2}) = 0$

86435116182. $4\sqrt{2}x + 5y - 4\sqrt{2} = 0$

Question Number : 79 Question Id : 8643515389 Question Type : MCQ Option Shuffling : Yes Is Question Mandatory : No

Correct Marks : 4 Wrong Marks : 1

The solutions of the equation

$$\begin{vmatrix} 1 + \sin^2 x & \sin^2 x & \sin^2 x \\ \cos^2 x & 1 + \cos^2 x & \cos^2 x \\ 4 \sin 2x & 4 \sin 2x & 1 + 4 \sin 2x \end{vmatrix} = 0, (0 < x < \pi), \text{ are :}$$

Options :

86435116183. $\frac{\pi}{6}, \frac{5\pi}{6}$

86435116184. $\frac{5\pi}{12}, \frac{7\pi}{12}$

86435116185. $\frac{7\pi}{12}, \frac{11\pi}{12}$

86435116186. $\frac{\pi}{12}, \frac{\pi}{6}$

Question Number : 79 Question Id : 8643515389 Question Type : MCQ Option Shuffling : Yes Is Question Mandatory : No

Correct Marks : 4 Wrong Marks : 1

$$\begin{vmatrix} 1 + \sin^2 x & \sin^2 x & \sin^2 x \\ \cos^2 x & 1 + \cos^2 x & \cos^2 x \\ 4 \sin 2x & 4 \sin 2x & 1 + 4 \sin 2x \end{vmatrix} = 0, (0 < x < \pi) \text{ সমীকরণটোৰ সমাধানবোৰ হ'ব :}$$

Options :

86435116183. $\frac{\pi}{6}, \frac{5\pi}{6}$

86435116184. $\frac{5\pi}{12}, \frac{7\pi}{12}$

86435116185. $\frac{7\pi}{12}, \frac{11\pi}{12}$

86435116186. $\frac{\pi}{12}, \frac{\pi}{6}$

Question Number : 80 Question Id : 8643515390 Question Type : MCQ Option Shuffling : Yes Is Question Mandatory : No

Correct Marks : 4 Wrong Marks : 1

A vector \vec{a} has components $3p$ and 1 with respect to a rectangular cartesian system. This system is rotated through a certain angle about the origin in the counter clockwise sense. If, with respect to new system, \vec{a} has components $p + 1$ and $\sqrt{10}$, then a value of p is equal to :

Options :

86435116187. 1

86435116188. -1

86435116189. $\frac{4}{5}$

86435116190. $-\frac{5}{4}$

Question Number : 80 Question Id : 8643515390 Question Type : MCQ Option Shuffling : Yes Is

Question Mandatory : No

Correct Marks : 4 Wrong Marks : 1

আয়তীয় কার্ভেজীয় প্রণালী সাপেক্ষে এটা ভেক্টর \vec{a} ৰ $3p$ আৰু 1 দুটা উপাংশ। মূলবিন্দু সাপেক্ষে ঘড়ীৰ কাঁটাৰ একেদিশত

এই প্রণালীটোক ঘূৰোৱা হ'ল। যদি নতুন প্রণালীটো সাপেক্ষে \vec{a} ৰ উপাংশ $p+1$ আৰু $\sqrt{10}$ হয়, তেন্তে p সমান

হ'ব :

Options :

86435116187. 1

86435116188. -1

86435116189. $\frac{4}{5}$

86435116190. $-\frac{5}{4}$

Mathematics Section B

Section Id :	864351360
Section Number :	6
Section type :	Online
Mandatory or Optional :	Mandatory
Number of Questions :	10
Number of Questions to be attempted :	5
Section Marks :	20
Mark As Answered Required? :	Yes
Sub-Section Number :	1
Sub-Section Id :	864351360
Question Shuffling Allowed :	Yes

Question Number : 81 Question Id : 8643515391 Question Type : SA

Correct Marks : 4 Wrong Marks : 0

Let z_1, z_2 be the roots of the equation $z^2 + az + 12 = 0$ and z_1, z_2 form an equilateral triangle with origin. Then, the value of $|a|$ is _____.

Response Type : Numeric

Evaluation Required For SA : Yes

Show Word Count : Yes

Answers Type : Equal

Text Areas : PlainText

Possible Answers :

100

Question Number : 81 Question Id : 8643515391 Question Type : SA

Correct Marks : 4 Wrong Marks : 0

ধৰা হ'ল $z^2 + az + 12 = 0$ সমীকৰণটোৰ z_1 আৰু z_2 মূল আৰু z_1, z_2 য়ে মূলবিন্দুৰ সৈতে এটা সমবাহু ত্ৰিভুজ গঠন কৰে। তেন্তে $|a|$ ৰ মান হ'ব _____।

Response Type : Numeric

Evaluation Required For SA : Yes

Show Word Count : Yes

Answers Type : Equal

Text Areas : PlainText

Possible Answers :

100

Question Number : 82 Question Id : 8643515392 Question Type : SA

Correct Marks : 4 Wrong Marks : 0

Let $f(x)$ and $g(x)$ be two functions satisfying $f(x^2) + g(4-x) = 4x^3$ and $g(4-x) + g(x) = 0$, then

the value of $\int_{-4}^4 f(x^2) dx$ is _____.

Response Type : Numeric

Evaluation Required For SA : Yes

Show Word Count : Yes

Answers Type : Equal

Text Areas : PlainText

Possible Answers :

100

Question Number : 82 Question Id : 8643515392 Question Type : SA

Correct Marks : 4 Wrong Marks : 0

ধৰা হ'ল $f(x)$ আৰু $g(x)$ দুটা ফলন যিয়ে $f(x^2) + g(4-x) = 4x^3$ আৰু $g(4-x) + g(x) = 0$, ক সিদ্ধ কৰে, তেন্তে

$\int_{-4}^4 f(x^2) dx$ ৰ মান হ'ব _____।

Response Type : Numeric

Evaluation Required For SA : Yes

Show Word Count : Yes

Answers Type : Equal

Text Areas : PlainText

Possible Answers :

100

Question Number : 83 Question Id : 8643515393 Question Type : SA

Correct Marks : 4 Wrong Marks : 0

If $f(x) = \int \frac{5x^8 + 7x^6}{(x^2 + 1 + 2x^7)^2} dx$, ($x \geq 0$), $f(0) = 0$ and $f(1) = \frac{1}{K}$, then the value of K is

_____.

Response Type : Numeric

Evaluation Required For SA : Yes

Show Word Count : Yes

Answers Type : Equal

Text Areas : PlainText

Possible Answers :

100

Question Number : 83 Question Id : 8643515393 Question Type : SA

Correct Marks : 4 Wrong Marks : 0

যদি $f(x) = \int \frac{5x^8 + 7x^6}{(x^2 + 1 + 2x^7)^2} dx$, ($x \geq 0$), $f(0) = 0$ আৰু $f(1) = \frac{1}{K}$, তেন্তে K ৰ মান হ'ব _____।

Response Type : Numeric

Evaluation Required For SA : Yes

Show Word Count : Yes

Answers Type : Equal

Text Areas : PlainText

Possible Answers :

100

Question Number : 84 Question Id : 8643515394 Question Type : SA

Correct Marks : 4 Wrong Marks : 0

A square ABCD has all its vertices on the curve $x^2y^2 = 1$. The midpoints of its sides also lie on the same curve. Then, the square of area of ABCD is _____.

Response Type : Numeric

Evaluation Required For SA : Yes

Show Word Count : Yes

Answers Type : Equal

Text Areas : PlainText

Possible Answers :

100

Question Number : 84 Question Id : 8643515394 Question Type : SA

Correct Marks : 4 Wrong Marks : 0

ABCD বর্গৰ সকলোবোৰ শীৰ্ষবিন্দু $x^2+y^2=1$ বক্ৰৰ ওপৰত আছে। ইয়াৰ বাহুবোৰৰ মধ্যবিন্দুবোৰো একে বক্ৰৰ ওপৰত থাকে। তেন্তে ABCD বর্গৰ কালি হ'ব _____।

Response Type : Numeric

Evaluation Required For SA : Yes

Show Word Count : Yes

Answers Type : Equal

Text Areas : PlainText

Possible Answers :

100

Question Number : 85 Question Id : 8643515395 Question Type : SA

Correct Marks : 4 Wrong Marks : 0

Let the plane $ax + by + cz + d = 0$ bisect the line joining the points $(4, -3, 1)$ and $(2, 3, -5)$ at the right angles. If a, b, c, d are integers, then the minimum value of $(a^2 + b^2 + c^2 + d^2)$ is _____.

Response Type : Numeric

Evaluation Required For SA : Yes

Show Word Count : Yes

Answers Type : Equal

Text Areas : PlainText

Possible Answers :

100

Question Number : 85 Question Id : 8643515395 Question Type : SA

Correct Marks : 4 Wrong Marks : 0

ধৰা হ'ল $ax + by + cz + d = 0$ সমতলখনে $(4, -3, 1)$ আৰু $(2, 3, -5)$ বিন্দু সংযোগী ৰেখাখণ্ডক সমকোণত সমদ্বিখণ্ডিত কৰে। যদি a, b, c, d অখণ্ড হয়, তেন্তে $(a^2 + b^2 + c^2 + d^2)$ ৰ সৰ্বনিম্ন মান হ'ব _____।

Response Type : Numeric

Evaluation Required For SA : Yes

Show Word Count : Yes

Answers Type : Equal

Text Areas : PlainText

Possible Answers :

100

Question Number : 86 Question Id : 8643515396 Question Type : SA

Correct Marks : 4 Wrong Marks : 0

The equation of the planes parallel to the plane $x - 2y + 2z - 3 = 0$ which are at unit distance from the point $(1, 2, 3)$ is $ax + by + cz + d = 0$. If $(b - d) = K(c - a)$, then the positive value of K is _____.

Response Type : Numeric

Evaluation Required For SA : Yes

Show Word Count : Yes

Answers Type : Equal

Text Areas : PlainText

Possible Answers :

100

Question Number : 86 Question Id : 8643515396 Question Type : SA

Correct Marks : 4 Wrong Marks : 0

$x - 2y + 2z - 3 = 0$ সমতলৰ সমান্তৰাল হোৱা আৰু $(1, 2, 3)$ বিন্দুৰ পৰা একক দূৰত্বত থকা সমতলৰ সমীকৰণটো হ'ল $ax + by + cz + d = 0$ । যদি $(b - d) = K(c - a)$, তেন্তে K ৰ ধনাত্মক মান হ'ব _____।

Response Type : Numeric

Evaluation Required For SA : Yes

Show Word Count : Yes

Answers Type : Equal

Text Areas : PlainText

Possible Answers :

100

Question Number : 87 Question Id : 8643515397 Question Type : SA

Correct Marks : 4 Wrong Marks : 0

The mean age of 25 teachers in a school is 40 years. A teacher retires at the age of 60 years and a new teacher is appointed in his place. If the mean age of the teachers in this school now is 39 years, then the age (in years) of the newly appointed teacher is _____.

Response Type : Numeric

Evaluation Required For SA : Yes

Show Word Count : Yes

Answers Type : Equal

Text Areas : PlainText

Possible Answers :

100

Question Number : 87 Question Id : 8643515397 Question Type : SA

Correct Marks : 4 Wrong Marks : 0

এখন বিদ্যালয়ৰ 25 জন শিক্ষকৰ গড় বয়স 40 বছৰ। এজন শিক্ষকে 60 বছৰ বয়সত অৱসৰ গ্ৰহণ কৰে আৰু তেখেতৰ স্থানত এজন নতুন শিক্ষক নিযুক্তি দিয়া হয়। যদি এইখন বিদ্যালয়ৰ শিক্ষক সকলৰ বৰ্তমান গড় বয়স 39 বছৰ হয়, তেন্তে নতুনকৈ নিযুক্তি প্ৰাপ্ত শিক্ষকজনৰ বয়স হ'ব _____। (বছৰৰ হিচাপত)

Response Type : Numeric

Evaluation Required For SA : Yes

Show Word Count : Yes

Answers Type : Equal

Text Areas : PlainText

Possible Answers :

100

Question Number : 88 Question Id : 8643515398 Question Type : SA

Correct Marks : 4 Wrong Marks : 0

The number of times the digit 3 will be written when listing the integers from 1 to 1000 is

_____.

Response Type : Numeric

Evaluation Required For SA : Yes

Show Word Count : Yes

Answers Type : Equal

Text Areas : PlainText

Possible Answers :

100

Question Number : 88 Question Id : 8643515398 Question Type : SA

Correct Marks : 4 Wrong Marks : 0

যেতিয়া 1 ৰ পৰা 1000 লৈ অখণ্ড সংখ্যাবোৰ গণি থকা হয় তেতিয়া 3 অংকটো লিখিব পৰা সংখ্যাৰ সংখ্যা হ'ব

_____।

Response Type : Numeric

Evaluation Required For SA : Yes

Show Word Count : Yes

Answers Type : Equal

Text Areas : PlainText

Possible Answers :

100

Question Number : 89 Question Id : 8643515399 Question Type : SA

Correct Marks : 4 Wrong Marks : 0

The missing value in the following figure is _____.

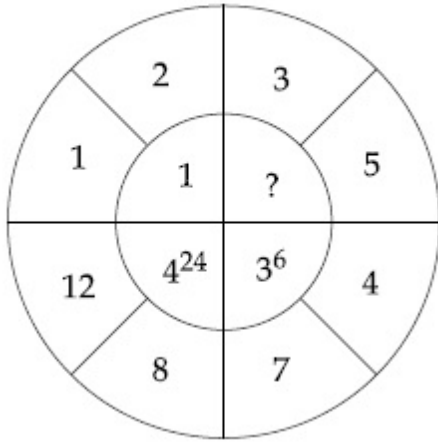

Response Type : Numeric

Evaluation Required For SA : Yes

Show Word Count : Yes

Answers Type : Equal

Text Areas : PlainText

Possible Answers :

100

Question Number : 89 **Question Id :** 8643515399 **Question Type :** SA

Correct Marks : 4 **Wrong Marks :** 0

চিত্রটোত নিখোঁজ হোৱা মানটো হ'ব _____।

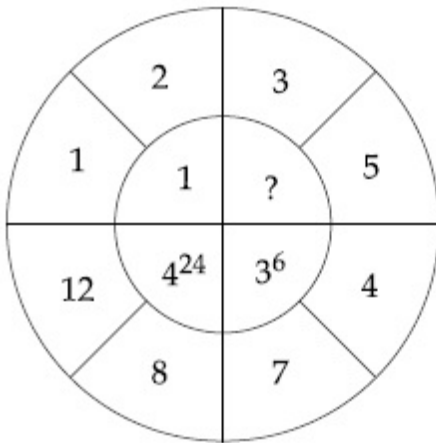

Response Type : Numeric

Evaluation Required For SA : Yes

Show Word Count : Yes

Answers Type : Equal

Text Areas : PlainText

Possible Answers :

100

Question Number : 90 **Question Id :** 8643515400 **Question Type :** SA

Correct Marks : 4 Wrong Marks : 0

The number of solutions of the equation $|\cot x| = \cot x + \frac{1}{\sin x}$ in the interval $[0, 2\pi]$ is

_____.

Response Type : Numeric

Evaluation Required For SA : Yes

Show Word Count : Yes

Answers Type : Equal

Text Areas : PlainText

Possible Answers :

100

Question Number : 90 Question Id : 8643515400 Question Type : SA

Correct Marks : 4 Wrong Marks : 0

$|\cot x| = \cot x + \frac{1}{\sin x}$ সমীকৰণটোৰ $[0, 2\pi]$ অন্তৰালত সমাধানৰ সংখ্যা হ'ব _____।

Response Type : Numeric

Evaluation Required For SA : Yes

Show Word Count : Yes

Answers Type : Equal

Text Areas : PlainText

Possible Answers :

100