

# National Testing Agency

<b>Question Paper Name :</b>	B TECH EG 18th March 2021 Shift 2
<b>Subject Name :</b>	B TECH EG
<b>Creation Date :</b>	2021-03-18 19:51:25
<b>Duration :</b>	180
<b>Number of Questions :</b>	90
<b>Total Marks :</b>	300
<b>Display Marks:</b>	Yes

## B TECH EG

<b>Group Number :</b>	1
<b>Group Id :</b>	86435167
<b>Group Maximum Duration :</b>	0
<b>Group Minimum Duration :</b>	180
<b>Show Attended Group? :</b>	No
<b>Edit Attended Group? :</b>	No
<b>Break time :</b>	0
<b>Group Marks :</b>	300
<b>Is this Group for Examiner? :</b>	No

## Physics Section A

<b>Section Id :</b>	864351397
<b>Section Number :</b>	1
<b>Section type :</b>	Online
<b>Mandatory or Optional :</b>	Mandatory
<b>Number of Questions :</b>	20
<b>Number of Questions to be attempted :</b>	20
<b>Section Marks :</b>	80
<b>Mark As Answered Required? :</b>	Yes
<b>Sub-Section Number :</b>	1
<b>Sub-Section Id :</b>	864351397
<b>Question Shuffling Allowed :</b>	Yes

**Question Number : 1 Question Id : 8643515941 Question Type : MCQ Option Shuffling : Yes Is Question Mandatory : No Correct Marks : 4 Wrong Marks : 1**

Consider a sample of oxygen behaving like an ideal gas. At 300 K, the ratio of root mean square (rms) velocity to the average velocity of gas molecule would be :

(Molecular weight of oxygen is 32 g/mol;  $R = 8.3 \text{ J K}^{-1} \text{ mol}^{-1}$ )

Options :

$$\sqrt{\frac{3\pi}{8}}$$

86435117821.

$$\sqrt{\frac{8\pi}{3}}$$

86435117822.

$$\sqrt{\frac{8}{3}}$$

86435117823.

$$\sqrt{\frac{3}{3}}$$

86435117824.

Question Number : 1 Question Id : 8643515941 Question Type : MCQ Option Shuffling : Yes Is Question Mandatory : No

Correct Marks : 4 Wrong Marks : 1

ઓક્સિજન નમૂનાને ધ્યાનમાં લો કે જે આદર્શવાયુની જેમ વર્તે છે. 300 K તાપમાને સરેરાશ વર્ગિત વર્ગમૂળ (root mean square) વેગ અને વાયુ અણુની સરેરાશ વેગનો ગુણોત્તર \_\_\_\_\_ હશે.

(ઓક્સિજન માટે અણુભાર 32 g/mol છે ;  $R = 8.3 \text{ J K}^{-1} \text{ mol}^{-1}$ )

Options :

$$\sqrt{\frac{3\pi}{8}}$$

86435117821.

$$\sqrt{\frac{8\pi}{3}}$$

86435117822.

$$\sqrt{\frac{8}{3}}$$

86435117823.

86435117824.  $\sqrt{\frac{3}{3}}$

**Question Number : 2 Question Id : 8643515942 Question Type : MCQ Option Shuffling : Yes Is Question Mandatory : No**

**Correct Marks : 4 Wrong Marks : 1**

An object of mass  $m_1$  collides with another object of mass  $m_2$ , which is at rest. After the collision the objects move with equal speeds in opposite direction. The ratio of the masses  $m_2 : m_1$  is :

**Options :**

86435117825. 1 : 1

86435117826. 1 : 2

86435117827. 2 : 1

86435117828. 3 : 1

**Question Number : 2 Question Id : 8643515942 Question Type : MCQ Option Shuffling : Yes Is Question Mandatory : No**

**Correct Marks : 4 Wrong Marks : 1**

એક  $m_1$  દળ ધરાવતો પદાર્થ બીજા  $m_2$  દળ ધરાવતાં પદાર્થ કે જે સ્થિર છે તેની સાથે સંઘાત અનુભવે છે. સંઘાત બાદ બંને પદાર્થો સમાન ઝડપ સાથે વિરુદ્ધ દિશામાં ગતિ કરે છે. દળોનો ગુણોત્તર  $m_2 : m_1$  \_\_\_\_\_ થશે.

**Options :**

86435117825. 1 : 1

86435117826. 1 : 2

86435117827. 2 : 1

86435117828. 3 : 1

**Question Number : 3 Question Id : 8643515943 Question Type : MCQ Option Shuffling : Yes Is Question Mandatory : No**

**Correct Marks : 4 Wrong Marks : 1**

A particle of mass  $m$  moves in a circular orbit under the central potential field,  $U(r) = -\frac{C}{r}$ , where  $C$  is a positive constant.

The correct radius – velocity graph of the particle's motion is :

**Options :**

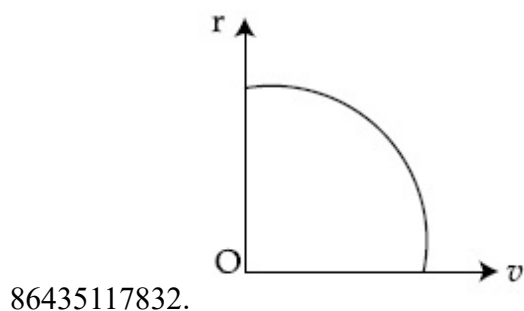
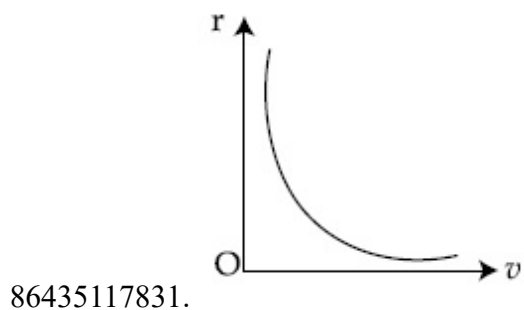
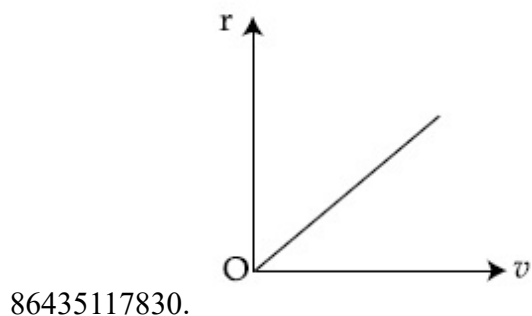
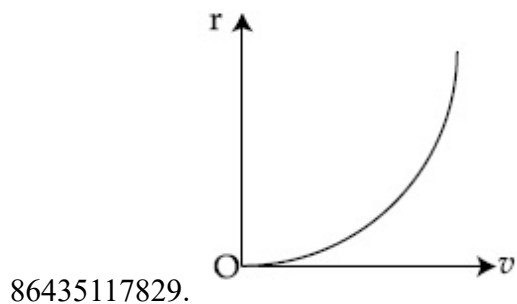

**Question Number : 3 Question Id : 8643515943 Question Type : MCQ Option Shuffling : Yes Is Question Mandatory : No**

Correct Marks : 4 Wrong Marks : 1

m દળ ધરાવતું એક કણ  $U(r) = -\frac{C}{r}$ ; જ્યાં C એ ધન અચળાંક, થી અપાતા કેન્દ્રીય સ્થિતિમાન ક્ષેત્રની અસર લેઈળ વર્તુળાકાર કક્ષામાં ગતિ કરે છે. કણની ગતિ માટે ત્રિજ્યા - વેગને દર્શાવતો સાચો આલેખ \_\_\_\_\_ છે.

Options :

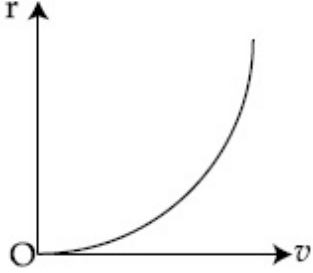

86435117829.

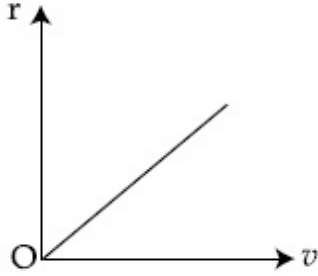

86435117830.

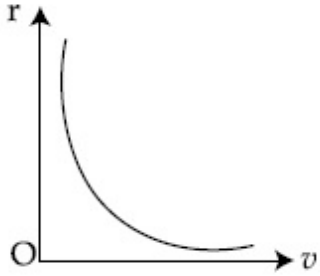

86435117831.

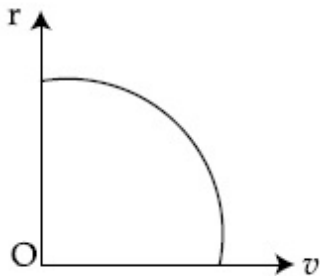

86435117832.

Question Number : 4 Question Id : 8643515944 Question Type : MCQ Option Shuffling : Yes Is Question Mandatory : No

**Correct Marks : 4 Wrong Marks : 1**

A solid cylinder of mass  $m$  is wrapped with an inextensible light string and, is placed on a rough inclined plane as shown in the figure. The frictional force acting between the cylinder and the inclined plane is :

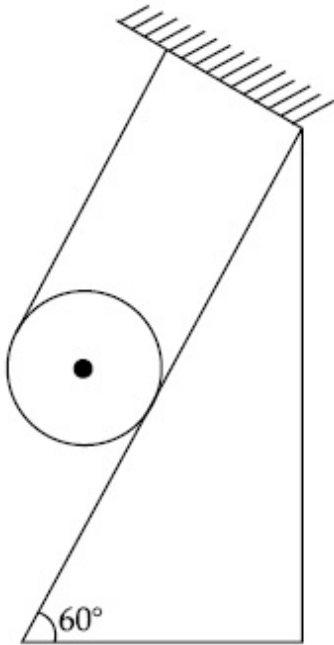

[The coefficient of static friction,  $\mu_s$  is 0.4]

**Options :**

86435117833.  $\frac{mg}{5}$

86435117834.  $5 mg$

86435117835.  $\frac{7}{2} mg$

86435117836.  $0$

**Question Number : 4 Question Id : 8643515944 Question Type : MCQ Option Shuffling : Yes Is Question Mandatory : No**

**Correct Marks : 4 Wrong Marks : 1**

m દળ ધરાવતાં એક ઘન નળાકારને હલકી અને ખેંચી ના શકાય તેવી દોરી વડે વીંટાળવામાં આવેલ છે અને તેને આકૃતિમાં દર્શાવ્યા અનુસાર એક ખરબચડા ઢળતા સમતલ (ઢોળાવ) ઉપર મૂકવામાં આવે છે. નળાકાર અને ઢોળાવ વચ્ચે પ્રવર્તતું ઘર્ષણબળ \_\_\_\_\_ થશે.

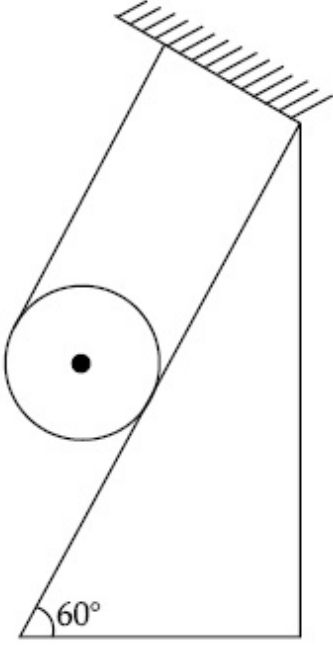

[સ્થિત ઘર્ષણાંક  $\mu_s$  0.4 છે.]

Options :

86435117833.  $\frac{mg}{5}$

86435117834.  $5 mg$

86435117835.  $\frac{7}{2} mg$

86435117836.  $0$

Question Number : 5 Question Id : 8643515945 Question Type : MCQ Option Shuffling : Yes Is Question Mandatory : No

Correct Marks : 4 Wrong Marks : 1

If the angular velocity of earth's spin is increased such that the bodies at the equator start floating, the duration of the day would be approximately :

[Take  $g = 10 \text{ ms}^{-2}$ , the radius of earth,  $R = 6400 \times 10^3 \text{ m}$ , Take  $\pi = 3.14$ ]

Options :

86435117837. does not change

86435117838. 1200 minutes

86435117839. 60 minutes

86435117840. 84 minutes

**Question Number : 5 Question Id : 8643515945 Question Type : MCQ Option Shuffling : Yes Is Question Mandatory : No**

**Correct Marks : 4 Wrong Marks : 1**

જો પૃથ્વીની પરિક્રમણનો કોણીયવેગ એવી રીતે વધારવામાં આવે છે કે જેથી વિષવવૃત્ત ઉપર રહેલો પદાર્થ તરવા માંડે તો દિવસની લંબાઈ લગભગ \_\_\_\_\_ જેટલી થશે.

[ $g = 10 \text{ ms}^{-2}$ ,  $R$ , પૃથ્વીની ત્રિજ્યા  $= 6400 \times 10^3 \text{ m}$ ,  $\pi = 3.14$  લો.]

**Options :**

86435117837. બદલાશે નહીં

86435117838. 1200 મિનીટ

86435117839. 60 મિનીટ

86435117840. 84 મિનીટ

**Question Number : 6 Question Id : 8643515946 Question Type : MCQ Option Shuffling : Yes Is Question Mandatory : No**

**Correct Marks : 4 Wrong Marks : 1**

Consider a uniform wire of mass  $M$  and length  $L$ . It is bent into a semicircle. Its moment of inertia about a line perpendicular to the plane of the wire passing through the centre is :

**Options :**

86435117841.  $\frac{ML^2}{\pi^2}$



$$86435117842. \frac{1}{2} \frac{ML^2}{\pi^2}$$

$$86435117843. \frac{1}{4} \frac{ML^2}{\pi^2}$$

$$86435117844. \frac{2}{5} \frac{ML^2}{\pi^2}$$

**Question Number : 6 Question Id : 8643515946 Question Type : MCQ Option Shuffling : Yes Is Question Mandatory : No**

**Correct Marks : 4 Wrong Marks : 1**

M દળ અને L જેટલી લંબાઈ ધરાવતો સમાંગ તારને ધ્યાનમાં લો. તેને વાળીને અર્ધવર્તુળ બનાવવામાં આવે છે. તેના કેન્દ્રમાંથી પસાર થતી અને તારના સમતલને લંબ રેખાને અનુલક્ષીને જડત્વની ચાકમાત્રા \_\_\_\_\_ થશે.

**Options :**

$$86435117841. \frac{ML^2}{\pi^2}$$

$$86435117842. \frac{1}{2} \frac{ML^2}{\pi^2}$$

$$86435117843. \frac{1}{4} \frac{ML^2}{\pi^2}$$

$$86435117844. \frac{2}{5} \frac{ML^2}{\pi^2}$$

**Question Number : 7 Question Id : 8643515947 Question Type : MCQ Option Shuffling : Yes Is Question Mandatory : No**

**Correct Marks : 4 Wrong Marks : 1**

The speed of electrons in a scanning electron microscope is  $1 \times 10^7 \text{ ms}^{-1}$ . If the protons having the same speed are used instead of electrons, then the resolving power of scanning proton microscope will be changed by a factor of :

**Options :**

86435117845.  $\sqrt{1837}$

86435117846.  $\frac{1}{1837}$

86435117847.  $\frac{1}{\sqrt{1837}}$

86435117848.  $\sqrt{\sqrt{1837}}$

**Question Number : 7 Question Id : 8643515947 Question Type : MCQ Option Shuffling : Yes Is Question Mandatory : No**

**Correct Marks : 4 Wrong Marks : 1**

સ્કેનીંગ ઇલેક્ટ્રોન સૂક્ષ્મદર્શક (scanning electron microscope) માં ઇલેક્ટ્રોનની ઝડપ  $1 \times 10^7 \text{ ms}^{-1}$  છે. જો ઇલેક્ટ્રોનને બદલે આટલી જ ઝડપ સાથેના પ્રોટોનનો ઉપયોગ કરવામાં આવે તો સ્કેનીંગ પ્રોટોન સૂક્ષ્મદર્શકની વિભેદન શક્તિ \_\_\_\_\_ પ્રમાણે બદલાશે.

**Options :**

86435117845.  $\sqrt{1837}$

86435117846.  $\frac{1}{1837}$

86435117847.  $\frac{1}{\sqrt{1837}}$

86435117848.  $\sqrt{\sqrt{1837}}$

**Question Number : 8 Question Id : 8643515948 Question Type : MCQ Option Shuffling : Yes Is Question Mandatory : No**

**Correct Marks : 4 Wrong Marks : 1**

The velocity - displacement graph of a particle is shown in the figure.

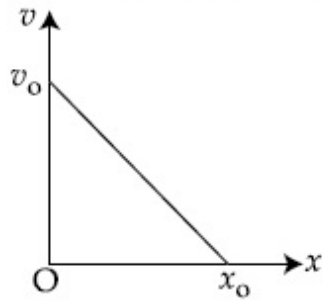

The acceleration - displacement graph of the same particle is represented by :

Options :

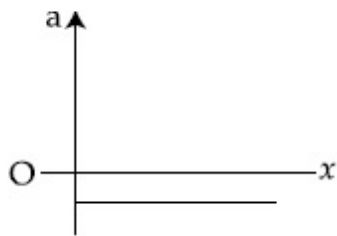

86435117849.

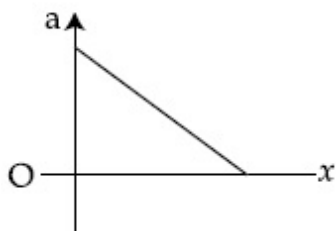

86435117850.

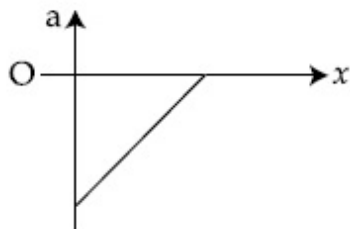

86435117851.

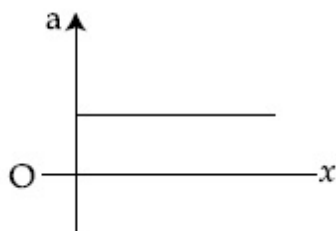

86435117852.

Question Number : 8 Question Id : 8643515948 Question Type : MCQ Option Shuffling : Yes Is Question Mandatory : No

Correct Marks : 4 Wrong Marks : 1

કણ માટે વેગ-સ્થાનાંતરનો આલેખ આકૃતિમાં દર્શાવેલ છે.

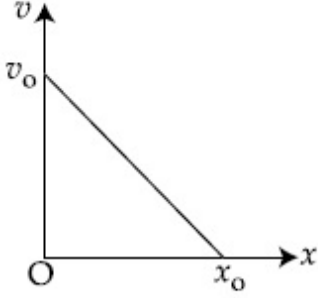

આ જ કણ માટે પ્રવેગ-સ્થાનાંતરનો આલેખ \_\_\_\_\_ વડે રજૂ કરી શકાય.

Options :

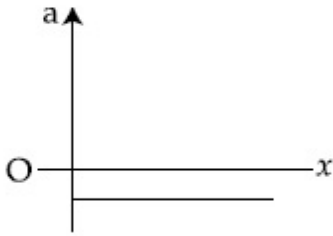

86435117849.

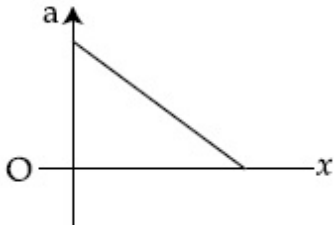

86435117850.

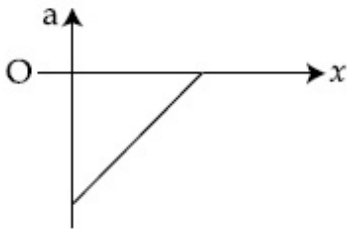

86435117851.

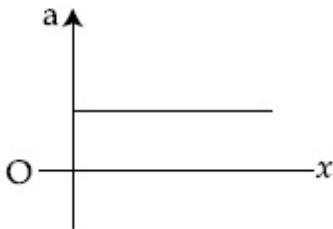

86435117852.

Question Number : 9 Question Id : 8643515949 Question Type : MCQ Option Shuffling : Yes Is

**Question Mandatory : No**

**Correct Marks : 4 Wrong Marks : 1**

For an adiabatic expansion of an ideal gas, the fractional change in its pressure is equal to (where  $\gamma$  is the ratio of specific heats) :

**Options :**

$$-\gamma \frac{dV}{V}$$

86435117853.

$$-\gamma \frac{V}{dV}$$

86435117854.

$$-\frac{1}{\gamma} \frac{dV}{V}$$

86435117855.

$$\frac{dV}{V}$$

86435117856.

**Question Number : 9 Question Id : 8643515949 Question Type : MCQ Option Shuffling : Yes Is**

**Question Mandatory : No**

**Correct Marks : 4 Wrong Marks : 1**

આદર્શવાયુની સમોષ્મી વિસ્તરણ માટે, દબાણમાં આંશિક ફેરફાર \_\_\_\_\_ ને બરાબર થશે. (જ્યાં  $\gamma$  એ વિશિષ્ટ ઉષ્માઓનો ગુણોત્તર છે.)

**Options :**

$$-\gamma \frac{dV}{V}$$

86435117853.

$$-\gamma \frac{V}{dV}$$

86435117854.

$$-\frac{1}{\gamma} \frac{dV}{V}$$

86435117855.

$$\frac{dV}{V}$$

86435117856.

**Question Number : 10 Question Id : 8643515950 Question Type : MCQ Option Shuffling : Yes Is Question Mandatory : No Correct Marks : 4 Wrong Marks : 1**

The angular momentum of a planet of mass  $M$  moving around the sun in an elliptical orbit is  $\vec{L}$ . The magnitude of the areal velocity of the planet is :

**Options :**

$$\frac{L}{M}$$

86435117857.

$$\frac{L}{2M}$$

86435117858.

$$\frac{2L}{M}$$

86435117859.

$$\frac{4L}{M}$$

86435117860.

**Question Number : 10 Question Id : 8643515950 Question Type : MCQ Option Shuffling : Yes Is Question Mandatory : No Correct Marks : 4 Wrong Marks : 1**

$M$  દળ ધરાવતાં અને સૂર્યને ફરતે લંબવૃત્તીય કક્ષામાં ફરતાં ગ્રહનું કોણીય વેગમાન  $\vec{L}$  છે. ગ્રહની કક્ષીય વેગનું મૂલ્ય \_\_\_\_\_ થશે.

**Options :**

$$\frac{L}{M}$$

86435117857.

$$\frac{L}{2M}$$

86435117858.

$$86435117859. \frac{2L}{M}$$

$$86435117860. \frac{4L}{M}$$

**Question Number : 11 Question Id : 8643515951 Question Type : MCQ Option Shuffling : Yes Is Question Mandatory : No**

**Correct Marks : 4 Wrong Marks : 1**

An ideal gas in a cylinder is separated by a piston in such a way that the entropy of one part is  $S_1$  and that of the other part is  $S_2$ . Given that  $S_1 > S_2$ . If the piston is removed then the total entropy of the system will be :

**Options :**

$$86435117861. S_1 \times S_2$$

$$86435117862. S_1 - S_2$$

$$86435117863. S_1 + S_2$$

$$86435117864. \frac{S_1}{S_2}$$

**Question Number : 11 Question Id : 8643515951 Question Type : MCQ Option Shuffling : Yes Is Question Mandatory : No**

**Correct Marks : 4 Wrong Marks : 1**

નળાકારમાં રહેલા આદર્શ વાયુને એક પિસ્ટન વડે એવી રીતે અલગ કરવામાં આવે છે કે જેથી એક ભાગની એન્ટ્રોપી  $S_1$  જ્યારે બીજા ભાગની એન્ટ્રોપી  $S_2$  બને છે.  $S_1 > S_2$  એમ આપેલ છે. જો પિસ્ટોનને દૂર કરવામાં આવે તો તંત્રની એન્ટ્રોપી \_\_\_\_\_ થશે.

**Options :**

$$86435117861. S_1 \times S_2$$

$$86435117862. S_1 - S_2$$

$$86435117863. S_1 + S_2$$

$$\frac{S_1}{S_2}$$

86435117864.

**Question Number : 12 Question Id : 8643515952 Question Type : MCQ Option Shuffling : Yes Is Question Mandatory : No**

**Correct Marks : 4 Wrong Marks : 1**

The function of time representing a simple harmonic motion with a period of  $\frac{\pi}{\omega}$  is :

**Options :**

86435117865.  $\sin(\omega t) + \cos(\omega t)$

86435117866.  $\sin^2(\omega t)$

86435117867.  $3 \cos\left(\frac{\pi}{4} - 2\omega t\right)$

86435117868.  $\cos(\omega t) + \cos(2\omega t) + \cos(3\omega t)$

**Question Number : 12 Question Id : 8643515952 Question Type : MCQ Option Shuffling : Yes Is Question Mandatory : No**

**Correct Marks : 4 Wrong Marks : 1**

$\frac{\pi}{\omega}$  જેટલા આવર્તકાળ ધરાવતી સરળ આવર્ત ગતિને રજૂ કરતું સમય આધારીત વિધેય \_\_\_\_\_ છે.

**Options :**

86435117865.  $\sin(\omega t) + \cos(\omega t)$

86435117866.  $\sin^2(\omega t)$

86435117867.  $3 \cos\left(\frac{\pi}{4} - 2\omega t\right)$

86435117868.  $\cos(\omega t) + \cos(2\omega t) + \cos(3\omega t)$



**Question Number : 13 Question Id : 8643515953 Question Type : MCQ Option Shuffling : Yes Is Question Mandatory : No Correct Marks : 4 Wrong Marks : 1**

In a series LCR circuit, the inductive reactance ( $X_L$ ) is  $10 \Omega$  and the capacitive reactance ( $X_C$ ) is  $4 \Omega$ . The resistance ( $R$ ) in the circuit is  $6 \Omega$ .

The power factor of the circuit is :

**Options :**

86435117869.  $\frac{1}{\sqrt{2}}$

86435117870.  $\frac{\sqrt{3}}{2}$

86435117871.  $\frac{1}{2}$

86435117872.  $\frac{1}{2\sqrt{2}}$

**Question Number : 13 Question Id : 8643515953 Question Type : MCQ Option Shuffling : Yes Is Question Mandatory : No Correct Marks : 4 Wrong Marks : 1**

LCR શ્રેણી પરિપથમાં, ગુંચળાનો અવબાધ ( $X_L$ )  $10 \Omega$  અને સંઘારકનો અવબાધ ( $X_C$ )  $4 \Omega$  છે. પરિપથમાં અવરોધ ( $R$ )  $6 \Omega$  નો છે. પરિપથનો પોવર ફેક્ટર \_\_\_\_\_ થશે.

**Options :**

86435117869.  $\frac{1}{\sqrt{2}}$

86435117870.  $\frac{\sqrt{3}}{2}$

86435117871.  $\frac{1}{2}$

$$86435117872. \frac{1}{2\sqrt{2}}$$

**Question Number : 14 Question Id : 8643515954 Question Type : MCQ Option Shuffling : Yes Is Question Mandatory : No**

**Correct Marks : 4 Wrong Marks : 1**

Which of the following statements are correct ?

- (A) Electric monopoles do not exist whereas magnetic monopoles exist.
- (B) Magnetic field lines due to a solenoid at its ends and outside cannot be completely straight and confined.
- (C) Magnetic field lines are completely confined within a toroid.
- (D) Magnetic field lines inside a bar magnet are not parallel.
- (E)  $\chi = -1$  is the condition for a perfect diamagnetic material, where  $\chi$  is its magnetic susceptibility.

Choose the correct answer from the options given below :

**Options :**

86435117873. (B) and (D) only

86435117874. (B) and (C) only

86435117875. (A) and (B) only

86435117876. (C) and (E) only

**Question Number : 14 Question Id : 8643515954 Question Type : MCQ Option Shuffling : Yes Is Question Mandatory : No**

**Correct Marks : 4 Wrong Marks : 1**

નીચે આપેલામાંથી કયા વિધાનો સાચાં છે?

- (A) વિદ્યુત એકધ્રુવી અસ્તિત્વ ધરાવતાં નથી જ્યારે ચુંબકીય એક ધ્રુવીઓ અસ્તિત્વ ધરાવે છે.
- (B) સોલેનોઈડ થી ઉત્પન્ન ચુંબકીય ક્ષેત્ર રેખાઓ તેના છેડાઓ અને બહારનાં ભાગમાં પૂર્ણ રીતે સીધી અને સિમીત હોતી નથી.
- (C) ટોરોઈડમાં ચુંબકીય ક્ષેત્ર રેખાઓ સંપૂર્ણ પણે સિમીત હોય છે.
- (D) ગળ્યા ચુંબકની અંદરના ભાગમાં ચુંબકીય ક્ષેત્ર રેખાઓ સમાંતર હોતી નથી.
- (E)  $\chi = -1$  શરત સંપૂર્ણ વિષમ ચુંબકીય (ડાયમેગ્નેટીક) પદાર્થ માટે છે, જ્યાં  $\chi$  એ ચુંબકીય ગ્રહણશીલતા (susceptibility) છે.

નીચે આપેલા વિકલ્પોમાંથી સાચો વિકલ્પ પસંદ કરો :

**Options :**

86435117873. ફક્ત (B) અને (D)

86435117874. ફક્ત (B) અને (C)

86435117875. ફક્ત (A) અને (B)

86435117876. ફક્ત (C) અને (E)

**Question Number : 15 Question Id : 8643515955 Question Type : MCQ Option Shuffling : Yes Is**

**Question Mandatory : No**

**Correct Marks : 4 Wrong Marks : 1**

The correct relation between  $\alpha$  (ratio of collector current to emitter current) and  $\beta$  (ratio of collector current to base current) of a transistor is :

**Options :**

$$\beta = \frac{\alpha}{1 + \alpha}$$

86435117877.

$$\alpha = \frac{\beta}{1 - \alpha}$$

86435117878.

$$\beta = \frac{1}{1 - \alpha}$$

86435117879.

$$\alpha = \frac{\beta}{1 + \beta}$$

86435117880.

**Question Number : 15 Question Id : 8643515955 Question Type : MCQ Option Shuffling : Yes Is Question Mandatory : No**

**Correct Marks : 4 Wrong Marks : 1**

ટ્રાન્ઝિસ્ટર માટે  $\alpha$  (કલેક્ટર પ્રવાહ અને એમીટર પ્રવાહનો ગુણોત્તર) અને  $\beta$  (કલેક્ટર પ્રવાહ અને બેઝ પ્રવાહનો ગુણોત્તર) વચ્ચેનો સાચો સંબંધ \_\_\_\_\_ છે.

**Options :**

$$\beta = \frac{\alpha}{1 + \alpha}$$

86435117877.

$$\alpha = \frac{\beta}{1 - \alpha}$$

86435117878.

$$\beta = \frac{1}{1 - \alpha}$$

86435117879.

$$\alpha = \frac{\beta}{1 + \beta}$$

86435117880.

**Question Number : 16 Question Id : 8643515956 Question Type : MCQ Option Shuffling : Yes Is Question Mandatory : No**

**Correct Marks : 4 Wrong Marks : 1**

A proton and an  $\alpha$ -particle, having kinetic energies  $K_p$  and  $K_\alpha$  respectively, enter into a magnetic field at right angles.

The ratio of the radii of trajectory of proton to that of  $\alpha$ -particle is 2 : 1. The ratio of  $K_p : K_\alpha$  is :

**Options :**

86435117881. 1 : 4

86435117882. 4 : 1

86435117883. 8 : 1

86435117884. 1 : 8

**Question Number : 16 Question Id : 8643515956 Question Type : MCQ Option Shuffling : Yes Is Question Mandatory : No**

**Correct Marks : 4 Wrong Marks : 1**

અનુક્રમે  $K_p$  અને  $K_\alpha$  જેટલી ગતિઊર્જા ધરાવતો એક પ્રોટોન અને  $\alpha$ -કણ ચુંબકીય ક્ષેત્રમાં લંબરૂપે દાખલ થાય છે. પ્રોટોન અને  $\alpha$ -કણની ગતિપથની ત્રિજ્યાઓનો ગુણોત્તર 2 : 1 છે.  $K_p : K_\alpha$  ગુણોત્તર \_\_\_\_\_ થશે.

**Options :**

86435117881. 1 : 4

86435117882. 4 : 1

86435117883. 8 : 1

86435117884. 1 : 8

**Question Number : 17 Question Id : 8643515957 Question Type : MCQ Option Shuffling : Yes Is Question Mandatory : No**

**Correct Marks : 4 Wrong Marks : 1**

Three rays of light, namely red (R), green (G) and blue (B) are incident on the face PQ of a right angled prism PQR as shown in the figure.

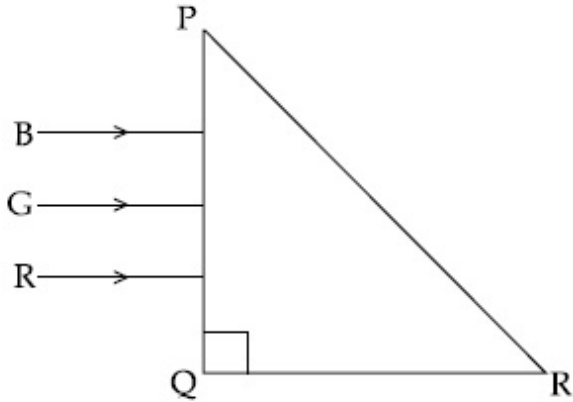

The refractive indices of the material of the prism for red, green and blue wavelength are 1.27, 1.42 and 1.49 respectively. The colour of the ray(s) emerging out of the face PR is :

**Options :**

86435117885. blue and green

86435117886. blue

86435117887. green

86435117888. red

**Question Number : 17 Question Id : 8643515957 Question Type : MCQ Option Shuffling : Yes Is**

**Question Mandatory : No**

**Correct Marks : 4 Wrong Marks : 1**

આકૃતિમાં દર્શાવ્યા પ્રમાણે એક કાટકોણ પ્રિઝમ PQR ની બાજુ PQ ઉપર રાતો (R), લીલો (G) અને વાદળી (B) એમ ત્રણ પ્રકાર કિરણો આપાત થાય છે.

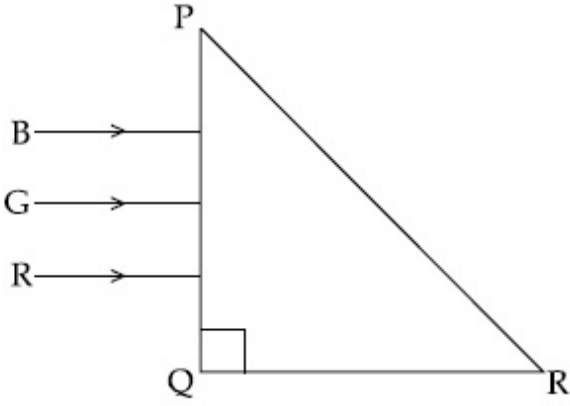

પ્રિઝમનાં દ્રવ્યનો રાતા, લીલા અને વાદળી માટે વક્રીભવનાંક અનુક્રમે 1.27, 1.42 અને 1.49 છે. PR બાજુમાંથી નિર્ગમન પામતા કિરણ (કિરણો) નો રંગ \_\_\_\_\_ હશે.

**Options :**

86435117885. વાદળી અને લીલો

86435117886. વાદળી

86435117887. લીલો

86435117888. રાતો

**Question Number : 18 Question Id : 8643515958 Question Type : MCQ Option Shuffling : Yes Is Question Mandatory : No**

**Correct Marks : 4 Wrong Marks : 1**

The time taken for the magnetic energy to reach 25% of its maximum value, when a solenoid of resistance R, inductance L is connected to a battery, is :

**Options :**

86435117889.  $\frac{L}{R} \ln 2$

86435117890.  $\frac{L}{R} \ln 5$

$$\frac{L}{R} \ln 10$$

86435117891.

infinite

86435117892.

**Question Number : 18 Question Id : 8643515958 Question Type : MCQ Option Shuffling : Yes Is Question Mandatory : No**

**Correct Marks : 4 Wrong Marks : 1**

જ્યારે R અવરોધ અને L ઈન્ડક્ટર ધરાવતાં સોલેનોઈડને બેટરી સાથે જોડતા, ચુંબકીય ઊર્જાને તેના મહત્તમ મૂલ્ય કરતાં 25% જેટલી થવા માટે લાગતો સમય \_\_\_\_\_ છે.

**Options :**

$$\frac{L}{R} \ln 2$$

86435117889.

$$\frac{L}{R} \ln 5$$

86435117890.

$$\frac{L}{R} \ln 10$$

86435117891.

અનંત

86435117892.

**Question Number : 19 Question Id : 8643515959 Question Type : MCQ Option Shuffling : Yes Is Question Mandatory : No**

**Correct Marks : 4 Wrong Marks : 1**

A plane electromagnetic wave propagating along  $y$ -direction can have the following pair of electric field  $(\vec{E})$  and magnetic field  $(\vec{B})$  components.

**Options :**

$$E_y, B_y \text{ or } E_z, B_z$$

86435117893.

$$E_x, B_y \text{ or } E_y, B_x$$

86435117894.



86435117895.  $E_x, B_z$  or  $E_z, B_x$

86435117896.  $E_y, B_x$  or  $E_x, B_y$

**Question Number : 19 Question Id : 8643515959 Question Type : MCQ Option Shuffling : Yes Is Question Mandatory : No Correct Marks : 4 Wrong Marks : 1**

$y$ -દિશામાં ગતિ કરતાં સમતલ વિદ્યુતચુંબકીય તરંગને વિદ્યુતક્ષેત્ર ( $\vec{E}$ ) અને ચુંબકીય ક્ષેત્ર ( $\vec{B}$ ) ના ઘટકો નીચે દર્શાવેલ \_\_\_\_\_ ભેડી થી આપી શકાય.

**Options :**

86435117893.  $E_y, B_y$  અથવા  $E_z, B_z$

86435117894.  $E_x, B_y$  અથવા  $E_y, B_x$

86435117895.  $E_x, B_z$  અથવા  $E_z, B_x$

86435117896.  $E_y, B_x$  અથવા  $E_x, B_y$

**Question Number : 20 Question Id : 8643515960 Question Type : MCQ Option Shuffling : Yes Is Question Mandatory : No Correct Marks : 4 Wrong Marks : 1**

The decay of a proton to neutron is :

**Options :**

86435117897. not possible as proton mass is less than the neutron mass

86435117898. possible only inside the nucleus

86435117899. always possible as it is associated only with  $\beta^+$  decay

86435117900. not possible but neutron to proton conversion is possible

**Question Number : 20 Question Id : 8643515960 Question Type : MCQ Option Shuffling : Yes Is**

**Question Mandatory : No**

**Correct Marks : 4 Wrong Marks : 1**

પ્રોટોન થી ન્યૂટ્રોનનો ક્ષય \_\_\_\_\_.

**Options :**

86435117897. શક્ય નથી કારણ કે પ્રોટોનનું દળ ન્યૂટ્રોનના દળ કરતાં ઓછું છે.

86435117898. ન્યૂક્લિયસની અંદર જ શક્ય છે.

86435117899. હંમેશા શક્ય છે કારણ કે તે  $\beta^+$  ક્ષય સાથે સંકળાયેલ છે.

86435117900. શક્ય નથી પરંતુ ન્યૂટ્રોનથી પ્રોટોન રૂપાંતરણ શક્ય છે.

## Physics Section B

<b>Section Id :</b>	864351398
<b>Section Number :</b>	2
<b>Section type :</b>	Online
<b>Mandatory or Optional :</b>	Mandatory
<b>Number of Questions :</b>	10
<b>Number of Questions to be attempted :</b>	5
<b>Section Marks :</b>	20
<b>Mark As Answered Required? :</b>	Yes
<b>Sub-Section Number :</b>	1
<b>Sub-Section Id :</b>	864351398
<b>Question Shuffling Allowed :</b>	Yes

**Question Number : 21 Question Id : 8643515961 Question Type : SA**

**Correct Marks : 4 Wrong Marks : 0**

The projectile motion of a particle of mass 5 g is shown in the figure.



The initial velocity of the particle is  $5\sqrt{2} \text{ ms}^{-1}$  and the air resistance is assumed to be negligible. The magnitude of the change in momentum between the points A and B is  $x \times 10^{-2} \text{ kgms}^{-1}$ . The value of  $x$ , to the nearest integer, is \_\_\_\_\_.

**Response Type :** Numeric

**Evaluation Required For SA :** Yes

**Show Word Count :** Yes

**Answers Type :** Equal

**Text Areas :** PlainText

**Possible Answers :**

100

**Question Number :** 21 **Question Id :** 8643515961 **Question Type :** SA

**Correct Marks :** 4 **Wrong Marks :** 0

આકૃતિમાં 5 g દળ ધરાવતાં કણની પ્રક્ષિપ્ત ગતિ દર્શાવેલ છે.

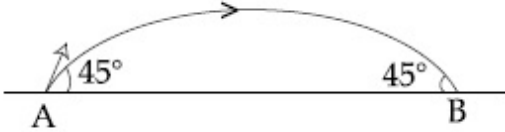

કણનો પ્રારંભિક વેગ  $5\sqrt{2} \text{ ms}^{-1}$  છે અને હવાનો અવરોધ અવગણી શકાય છે. બિંદુઓ A અને B વચ્ચે વેગમાનનાં બદલાવનું મૂલ્ય  $x \times 10^{-2} \text{ kgms}^{-1}$  છે.  $x$  નું મૂલ્ય, નજીકતમ પૂર્ણાંક માટે, \_\_\_\_\_ હશે.

**Response Type :** Numeric

**Evaluation Required For SA :** Yes

**Show Word Count :** Yes

**Answers Type :** Equal

**Text Areas :** PlainText

**Possible Answers :**

100

**Question Number :** 22 **Question Id :** 8643515962 **Question Type :** SA

**Correct Marks :** 4 **Wrong Marks :** 0

An infinite number of point charges, each carrying  $1 \mu\text{C}$  charge, are placed along the  $y$ -axis at  $y=1 \text{ m}, 2 \text{ m}, 4 \text{ m}, 8 \text{ m} \dots\dots\dots$ .

The total force on a  $1 \text{ C}$  point charge, placed at the origin, is  $x \times 10^3 \text{ N}$ .

The value of  $x$ , to the nearest integer, is \_\_\_\_\_.

[Take  $\frac{1}{4\pi\epsilon_0} = 9 \times 10^9 \text{ Nm}^2/\text{C}^2$ ]

**Response Type :** Numeric

**Evaluation Required For SA :** Yes

**Show Word Count :** Yes

**Answers Type :** Equal

**Text Areas :** PlainText

**Possible Answers :**

100

**Question Number :** 22 **Question Id :** 8643515962 **Question Type :** SA

**Correct Marks :** 4 **Wrong Marks :** 0

દરેક  $1 \mu\text{C}$  એવા અનંત બિંદુવત વિદ્યુતભારોને  $y$ -અક્ષ પર  $y=1 \text{ m}, 2 \text{ m}, 4 \text{ m}, 8 \text{ m} \dots\dots\dots$  પર મૂકવામાં આવેલા છે.

ઉગમબિંદુ પર રાખેલા  $1 \text{ C}$  બિંદુવત વિદ્યુતભાર લાગતું બળ  $x \times 10^3 \text{ N}$  છે.  $x$  નું મૂલ્ય, નજીકતમ પૂર્ણાંક માટે, \_\_\_\_\_

થશે. [ $\frac{1}{4\pi\epsilon_0} = 9 \times 10^9 \text{ Nm}^2/\text{C}^2$  લો.]

**Response Type :** Numeric

**Evaluation Required For SA :** Yes

**Show Word Count :** Yes

**Answers Type :** Equal

**Text Areas :** PlainText

**Possible Answers :**

100

**Question Number :** 23 **Question Id :** 8643515963 **Question Type :** SA

**Correct Marks :** 4 **Wrong Marks :** 0

Two wires of same length and thickness having specific resistances  $6 \Omega \text{ cm}$  and  $3 \Omega \text{ cm}$  respectively are connected in parallel. The effective resistivity is  $\rho \Omega \text{ cm}$ . The value of  $\rho$ , to the nearest integer, is \_\_\_\_\_.

**Response Type :** Numeric

**Evaluation Required For SA :** Yes

**Show Word Count :** Yes

**Answers Type :** Equal

**Text Areas :** PlainText

**Possible Answers :**

100

**Question Number : 23 Question Id : 8643515963 Question Type : SA**

**Correct Marks : 4 Wrong Marks : 0**

અનુક્રમે 6  $\Omega$  cm અને 3  $\Omega$  cm વિશિષ્ટ અવરોધ ધરાવતાં બે સમાન લંબાઈ અને જડાઈ ધરાવતાં તારોને સમાંતરમાં જોડવામાં આવ્યા છે. અસરકારક અવરોધકતા  $\rho$   $\Omega$  cm છે.  $\rho$  નું મૂલ્ય, નજીકત્તમ પૂર્ણાંક માટે, \_\_\_\_\_ થશે.

**Response Type :** Numeric

**Evaluation Required For SA :** Yes

**Show Word Count :** Yes

**Answers Type :** Equal

**Text Areas :** PlainText

**Possible Answers :**

100

**Question Number : 24 Question Id : 8643515964 Question Type : SA**

**Correct Marks : 4 Wrong Marks : 0**

A ball of mass 4 kg, moving with a velocity of  $10 \text{ ms}^{-1}$ , collides with a spring of length 8 m and force constant  $100 \text{ Nm}^{-1}$ . The length of the compressed spring is  $x$  m. The value of  $x$ , to the nearest integer, is \_\_\_\_\_.

**Response Type :** Numeric

**Evaluation Required For SA :** Yes

**Show Word Count :** Yes

**Answers Type :** Equal

**Text Areas :** PlainText

**Possible Answers :**

100

**Question Number : 24 Question Id : 8643515964 Question Type : SA**

**Correct Marks : 4 Wrong Marks : 0**

4 kg દ્રવ્ય ધરાવતો અને  $10 \text{ ms}^{-1}$  નાં વેગથી ગતિ કરતો એક બોલ, 8 m લંબાઈની અને  $100 \text{ Nm}^{-1}$  બળ અચળાંક ધરાવતી સ્પ્રિંગ સાથે અથડાય છે. દબાયેલી સ્પ્રિંગની લંબાઈ  $x$  m છે.  $x$  નું મૂલ્ય નજીકત્તમ પૂર્ણાંક માટે, \_\_\_\_\_ થશે.

**Response Type :** Numeric

**Evaluation Required For SA :** Yes

**Show Word Count :** Yes

**Answers Type :** Equal

**Text Areas :** PlainText

**Possible Answers :**

100

Question Number : 25 Question Id : 8643515965 Question Type : SA

Correct Marks : 4 Wrong Marks : 0

The typical output characteristics curve for a transistor working in the common-emitter configuration is shown in the figure.

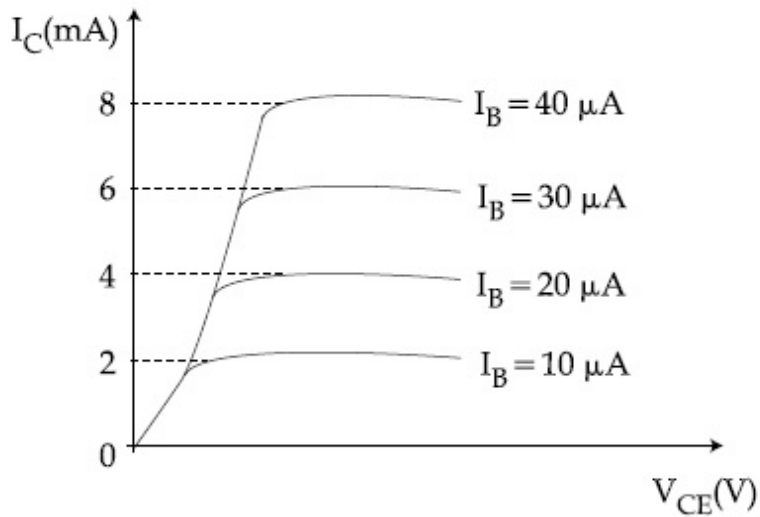

The estimated current gain from the figure is \_\_\_\_\_.

Response Type : Numeric

Evaluation Required For SA : Yes

Show Word Count : Yes

Answers Type : Equal

Text Areas : PlainText

Possible Answers :

100

Question Number : 25 Question Id : 8643515965 Question Type : SA

Correct Marks : 4 Wrong Marks : 0

કોમન-એમીટર સંરચનામાં કાર્યરત ટ્રાન્ઝીસ્ટર માટે ઓક્સ આઉટપુટ લાક્ષણિકતા આકૃતિમાં દર્શાવેલ છે.

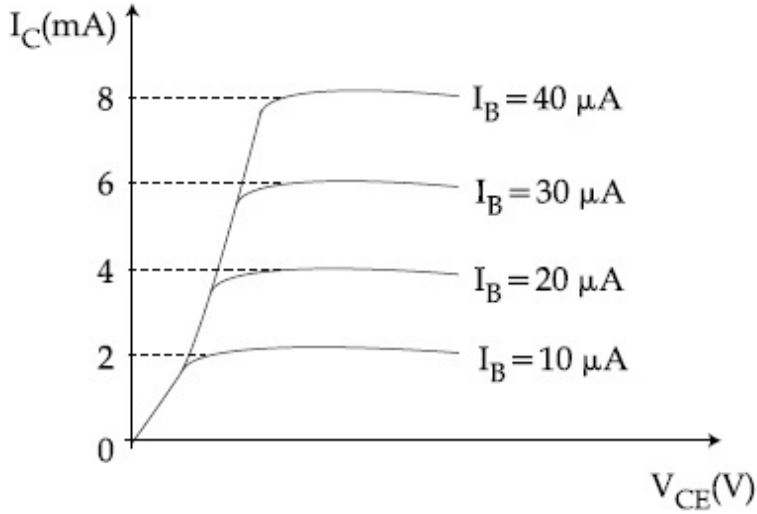

પરિપથ પરથી અંદાજીત પ્રવાહ લબ્ધિ \_\_\_\_\_ છે.

**Response Type :** Numeric

**Evaluation Required For SA :** Yes

**Show Word Count :** Yes

**Answers Type :** Equal

**Text Areas :** PlainText

**Possible Answers :**

100

**Question Number :** 26 **Question Id :** 8643515966 **Question Type :** SA

**Correct Marks :** 4 **Wrong Marks :** 0

Consider a 72 cm long wire AB as shown in the figure. The galvanometer jockey is placed at P on AB at a distance  $x$  cm from A. The galvanometer shows zero deflection.

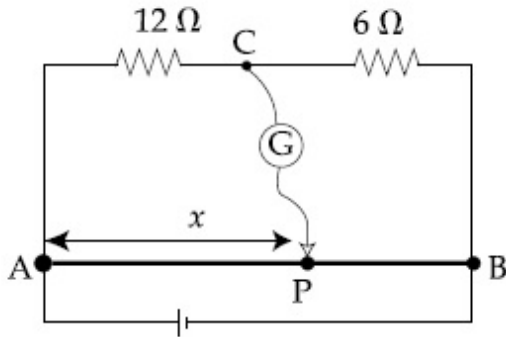

The value of  $x$ , to the nearest integer, is \_\_\_\_\_.

**Response Type :** Numeric

**Evaluation Required For SA :** Yes

Show Word Count : Yes

Answers Type : Equal

Text Areas : PlainText

Possible Answers :

100

Question Number : 26 Question Id : 8643515966 Question Type : SA

Correct Marks : 4 Wrong Marks : 0

આકૃતિમાં દર્શાવ્યા પ્રમાણે 72 cm લાંબા તારને ધ્યાનમાં લો. AB ઉપર ગેલ્વેનોમીટરની બેકી (કળ) ને A થી  $x$  cm અંતરે રહેલા P બિંદુ આગળ રાખવામાં આવે છે. ગેલ્વેનોમીટર શૂન્ય આવર્તન દર્શાવે છે.

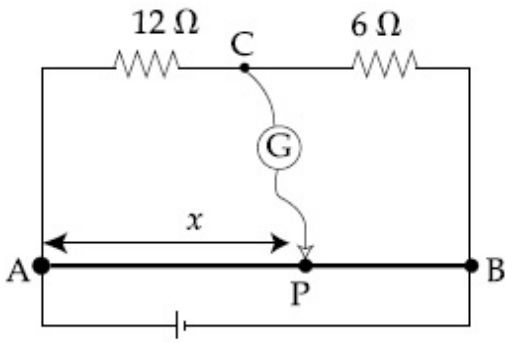

$x$  નું મૂલ્ય, નજીકતમ પૂર્ણાંક માટે, \_\_\_\_\_ થશે.

Response Type : Numeric

Evaluation Required For SA : Yes

Show Word Count : Yes

Answers Type : Equal

Text Areas : PlainText

Possible Answers :

100

Question Number : 27 Question Id : 8643515967 Question Type : SA

Correct Marks : 4 Wrong Marks : 0

A galaxy is moving away from the earth at a speed of  $286 \text{ kms}^{-1}$ . The shift in the wavelength of a redline at  $630 \text{ nm}$  is  $x \times 10^{-10} \text{ m}$ .

The value of  $x$ , to the nearest integer, is \_\_\_\_\_.

[Take the value of speed of light  $c$ , as  $3 \times 10^8 \text{ ms}^{-1}$ ]

Response Type : Numeric

Evaluation Required For SA : Yes

Show Word Count : Yes



Answers Type : Equal

Text Areas : PlainText

Possible Answers :

100

Question Number : 27 Question Id : 8643515967 Question Type : SA

Correct Marks : 4 Wrong Marks : 0

પૃથ્વીથી એક નિહારીકા (ગેલેક્સી)  $286 \text{ kms}^{-1}$  ની ઝડપથી દૂર જાય છે.  $630 \text{ nm}$  ની રાતીરેખા (Redline) ની તરંગલંબાઈમાં ફેરફાર  $x \times 10^{-10} \text{ m}$  મળે છે.  $x$  નું મૂલ્ય, નજીકત્તમ પૂર્ણાંક માટે, \_\_\_\_\_ થશે.

[પ્રકાશની ઝડપ  $c$  નું મૂલ્ય  $3 \times 10^8 \text{ ms}^{-1}$  લો.]

Response Type : Numeric

Evaluation Required For SA : Yes

Show Word Count : Yes

Answers Type : Equal

Text Areas : PlainText

Possible Answers :

100

Question Number : 28 Question Id : 8643515968 Question Type : SA

Correct Marks : 4 Wrong Marks : 0

Consider a water tank as shown in the figure. It's cross-sectional area is  $0.4 \text{ m}^2$ . The tank has an opening B near the bottom whose cross-section area is  $1 \text{ cm}^2$ . A load of  $24 \text{ kg}$  is applied on the water at the top when the height of the water level is  $40 \text{ cm}$  above the bottom, the velocity of water coming out the opening B is  $v \text{ ms}^{-1}$ .

The value of  $v$ , to the nearest integer, is \_\_\_\_\_.

[Take value of  $g$  to be  $10 \text{ ms}^{-2}$ ]

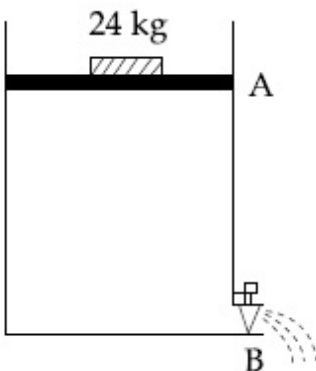

Response Type : Numeric

Evaluation Required For SA : Yes

Show Word Count : Yes

Answers Type : Equal

Text Areas : PlainText

Possible Answers :

100

Question Number : 28 Question Id : 8643515968 Question Type : SA

Correct Marks : 4 Wrong Marks : 0

આકૃતિમાં દર્શાવ્યા પ્રમાણે એક પાણીની ટાંકી ધ્યાનમાં લો. તેનો આડછેદનું ક્ષેત્રફળ  $0.4 \text{ m}^2$  છે. ટાંકીને તેના તળિયા આગળ છિદ્ર (ઢાંકણ) B છે કે જેના આડછેદનું ક્ષેત્રફળ  $1 \text{ cm}^2$  છે. પાણી ઉપર  $24 \text{ kg}$  નો લોડ (ભાર) લગાવવામાં આવે છે. જ્યારે પાણી લેવલની ઊંચાઈ તળિયાથી  $40 \text{ cm}$  હોય ત્યારે ઢાંકણ B માંથી બહાર આવતા પાણીનો વેગ  $v \text{ ms}^{-1}$  છે.  $v$  નું મૂલ્ય, નજીકત્તમ પૂર્ણાંક માટે, \_\_\_\_\_ થશે.

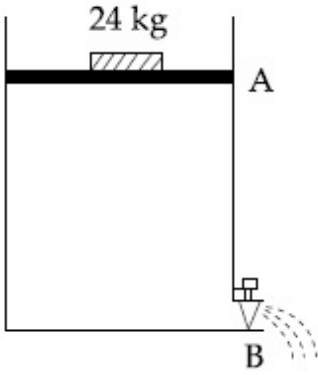
[g નું મૂલ્ય  $10 \text{ ms}^{-2}$  ]

Response Type : Numeric

Evaluation Required For SA : Yes

Show Word Count : Yes

Answers Type : Equal

Text Areas : PlainText

Possible Answers :

100

Question Number : 29 Question Id : 8643515969 Question Type : SA

Correct Marks : 4 Wrong Marks : 0

A TV transmission tower antenna is at a height of  $20 \text{ m}$ . Suppose that the receiving antenna is at.

- (i) ground level
- (ii) a height of  $5 \text{ m}$ .

The increase in antenna range in case (ii) relative to case (i) is  $n\%$ .

The value of  $n$ , to the nearest integer, is \_\_\_\_\_.

Response Type : Numeric

Evaluation Required For SA : Yes

Show Word Count : Yes

Answers Type : Equal

**Text Areas :** PlainText

**Possible Answers :**

100

**Question Number : 29 Question Id : 8643515969 Question Type : SA**

**Correct Marks : 4 Wrong Marks : 0**

એક ટીવી ટ્રાન્સમીશન એન્ટીના 20 m ઊંચાઈ પર છે. બે ગ્રાહ્ય (રીસીવીંગ) એન્ટીના

(i) ધરતી પર

(ii) 5 m ઊંચાઈ એ

હોય તો એન્ટીના અવધિમાં કિસ્સા (ii) માં કિસ્સા (i) ની સરખામણીમાં થતો વધારો  $n\%$  છે.  $n$  નું મૂલ્ય, નજીકતમ પૂર્ણાંક માટે, \_\_\_\_\_ થશે.

**Response Type :** Numeric

**Evaluation Required For SA :** Yes

**Show Word Count :** Yes

**Answers Type :** Equal

**Text Areas :** PlainText

**Possible Answers :**

100

**Question Number : 30 Question Id : 8643515970 Question Type : SA**

**Correct Marks : 4 Wrong Marks : 0**

The radius of a sphere is measured to be  $(7.50 \pm 0.85)$  cm. Suppose the percentage error in its volume is  $x$ .

The value of  $x$ , to the nearest  $x$ , is \_\_\_\_\_.

**Response Type :** Numeric

**Evaluation Required For SA :** Yes

**Show Word Count :** Yes

**Answers Type :** Equal

**Text Areas :** PlainText

**Possible Answers :**

100

**Question Number : 30 Question Id : 8643515970 Question Type : SA**

**Correct Marks : 4 Wrong Marks : 0**

ગોળાની ત્રિજ્યા  $(7.50 \pm 0.85)$  cm જેટલી મપાય છે. ધારો કે તેના કદની માપણીમાં પ્રતિશત ત્રૂટિ  $x$  છે.  $x$  નું મૂલ્ય, નજીકતમ પૂર્ણાંક માટે, \_\_\_\_\_ થશે.

**Response Type :** Numeric

**Evaluation Required For SA :** Yes

**Show Word Count :** Yes

**Answers Type :** Equal

**Text Areas :** PlainText

**Possible Answers :**

100

## Chemistry Section A

<b>Section Id :</b>	864351399
<b>Section Number :</b>	3
<b>Section type :</b>	Online
<b>Mandatory or Optional :</b>	Mandatory
<b>Number of Questions :</b>	20
<b>Number of Questions to be attempted :</b>	20
<b>Section Marks :</b>	80
<b>Mark As Answered Required? :</b>	Yes
<b>Sub-Section Number :</b>	1
<b>Sub-Section Id :</b>	864351399
<b>Question Shuffling Allowed :</b>	Yes

**Question Number : 31 Question Id : 8643515971 Question Type : MCQ Option Shuffling : Yes Is**

**Question Mandatory : No**

**Correct Marks : 4 Wrong Marks : 1**

A hard substance melts at high temperature and is an insulator in both solid and in molten state. This solid is most likely to be a/an :

**Options :**

86435117911. Ionic solid

86435117912. Covalent solid

86435117913. Metallic solid

86435117914. Molecular solid

**Question Number : 31 Question Id : 8643515971 Question Type : MCQ Option Shuffling : Yes Is**

**Question Mandatory : No**

**Correct Marks : 4 Wrong Marks : 1**

એક સખત પદાર્થ ઊંચા તાપમાને પીગળે છે અને તે ઘન અને પીગળેલ બંને અવસ્થામાં અવાહક છે. તો આ ઘન મોટે ભાગે \_\_\_\_\_ છે.

**Options :**

86435117911. આયનિક ધન

86435117912. સહસંયોજક ધન

86435117913. ધાત્વીક ધન

86435117914. આણ્વીય ધન

**Question Number : 32 Question Id : 8643515972 Question Type : MCQ Option Shuffling : Yes Is Question Mandatory : No**

**Correct Marks : 4 Wrong Marks : 1**

Given below are two statements :

**Statement I :** Bohr's theory accounts for the stability and line spectrum of  $\text{Li}^+$  ion.

**Statement II :** Bohr's theory was unable to explain the splitting of spectral lines in the presence of a magnetic field.

In the light of the above statements, choose the most appropriate answer from the options given below :

**Options :**

86435117915. Both statement I and statement II are true.

86435117916. Both statement I and statement II are false.

86435117917. Statement I is true but statement II is false.

86435117918. Statement I is false but statement II is true.

**Question Number : 32 Question Id : 8643515972 Question Type : MCQ Option Shuffling : Yes Is Question Mandatory : No**

**Correct Marks : 4 Wrong Marks : 1**

નીચે બે વિધાનો આપેલા છે.

**વિધાન I :** બ્લોર વાદ (શ્રીયરી) સ્થિરતાં અને  $\text{Li}^+$  આયનનો રેખા વર્ણપટ માટે ઉત્તરદાયી છે.

**વિધાન II :** ચુંબકીય ક્ષેત્રની હાજરીમાં બ્લોર વાદ વર્ણપટ રેખાઓનું વિભાજન સમજાવી શકતો નથી.

ઉપરનાં વિધાનોનાં સંદર્ભમાં, નીચે આપેલા વિકલ્પોમાંથી સૌથી વધુ બંધબેસતો જવાબ પસંદ કરો.

**Options :**

86435117915. બંને વિધાન I અને વિધાન II સાચાં છે.

86435117916. બંને વિધાન I અને વિધાન II ખોટા છે.

86435117917. વિધાન I સાચું છે પણ વિધાન II ખોટું છે.

86435117918. વિધાન I ખોટું છે પણ વિધાન II સાચું છે.

**Question Number : 33 Question Id : 8643515973 Question Type : MCQ Option Shuffling : Yes Is Question Mandatory : No**

**Correct Marks : 4 Wrong Marks : 1**

The charges on the colloidal CdS sol and  $TiO_2$  sol are, respectively :

**Options :**

86435117919. positive and positive

86435117920. negative and positive

86435117921. positive and negative

86435117922. negative and negative

**Question Number : 33 Question Id : 8643515973 Question Type : MCQ Option Shuffling : Yes Is Question Mandatory : No**

**Correct Marks : 4 Wrong Marks : 1**

CdS સોલ અને  $TiO_2$  સોલમાં કલિલો ઉપરનો ભાર (Charges) અનુક્રમે શોધો.

**Options :**

86435117919. ધન અને ધન

86435117920. ઋણ અને ધન

86435117921. ધન અને ઋણ

86435117922. ઋણ અને ઋણ

**Question Number : 34 Question Id : 8643515974 Question Type : MCQ Option Shuffling : Yes Is Question Mandatory : No Correct Marks : 4 Wrong Marks : 1**

The first ionization energy of magnesium is smaller as compared to that of elements X and Y, but higher than that of Z. The elements X, Y and Z, respectively, are :

**Options :**

86435117923. argon, chlorine and sodium

86435117924. chlorine, lithium and sodium

86435117925. argon, lithium and sodium

86435117926. neon, sodium and chlorine

**Question Number : 34 Question Id : 8643515974 Question Type : MCQ Option Shuffling : Yes Is Question Mandatory : No Correct Marks : 4 Wrong Marks : 1**

X અને Y તત્વોની સરખામણીમાં મેગ્નેશીયમની પ્રથમ આયનીકરણ ઊર્જા ઓછી પણ Z કરતાં વધારે છે. તો તત્વો X, Y અને Z અનુક્રમે શોધો :

**Options :**

86435117923. આર્ગોન, ક્લોરીન અને સોડિયમ

86435117924. ક્લોરીન, લિથીયમ અને સોડિયમ

86435117925. આર્ગોન, લિથીયમ અને સોડિયમ

86435117926. નિયોન, સોડિયમ અને ક્લોરીન

**Question Number : 35 Question Id : 8643515975 Question Type : MCQ Option Shuffling : Yes Is Question Mandatory : No Correct Marks : 4 Wrong Marks : 1**

Match List - I with List - II :

List - I	List - II
(a) Mercury	(i) Vapour phase refining
(b) Copper	(ii) Distillation Refining
(c) Silicon	(iii) Electrolytic Refining
(d) Nickel	(iv) Zone Refining

Choose the most appropriate answer from the option given below :

**Options :**

86435117927. (a)-(ii), (b)-(iii), (c)-(iv), (d)-(i)

86435117928. (a)-(i), (b)-(iv), (c)-(ii), (d)-(iii)

86435117929. (a)-(ii), (b)-(iii), (c)-(i), (d)-(iv)

86435117930. (a)-(ii), (b)-(iv), (c)-(iii), (d)-(i)

**Question Number : 35 Question Id : 8643515975 Question Type : MCQ Option Shuffling : Yes Is Question Mandatory : No**

**Correct Marks : 4 Wrong Marks : 1**

સૂચિ - I સાથે સૂચિ - II ને જોડો.

સૂચિ - I	સૂચિ - II
(a) મરક્યુરિ	(i) બાષ્પ અવસ્થા શુદ્ધિકરણ
(b) કોપર	(ii) નિસ્તંદન શુદ્ધિકરણ
(c) સિલીકોન	(iii) વિદ્યુતવિભાજ્ય શુદ્ધિકરણ
(d) નિકલ	(iv) ઝોન શુદ્ધિકરણ

નીચે આપેલા વિકલ્પોમાંથી સૌથી વધુ બંધબેસતો જવાબ પસંદ કરો.

**Options :**

86435117927. (a)-(ii), (b)-(iii), (c)-(iv), (d)-(i)

86435117928. (a)-(i), (b)-(iv), (c)-(ii), (d)-(iii)

86435117929. (a)-(ii), (b)-(iii), (c)-(i), (d)-(iv)



86435117930. (a)-(ii), (b)-(iv), (c)-(iii), (d)-(i)

**Question Number : 36 Question Id : 8643515976 Question Type : MCQ Option Shuffling : Yes Is Question Mandatory : No**

**Correct Marks : 4 Wrong Marks : 1**

In basic medium,  $H_2O_2$  exhibits which of the following reactions ?

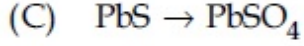
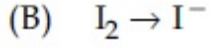
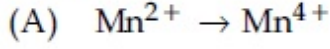

Choose the most appropriate answer from the options given below :

**Options :**

86435117931. (A) only

86435117932. (B) only

86435117933. (A), (B) only

86435117934. (A), (C) only

**Question Number : 36 Question Id : 8643515976 Question Type : MCQ Option Shuffling : Yes Is Question Mandatory : No**

**Correct Marks : 4 Wrong Marks : 1**

બેઝિક માધ્યમમાં,  $H_2O_2$  નીચે આપેલ કઈ પ્રક્રિયાઓ પ્રદર્શિત કરે છે ?

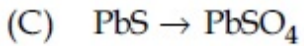
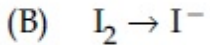
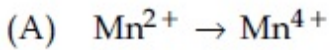

નીચે આપેલા વિકલ્પોમાંથી સૌથી વધુ બંધબેસતો જવાબ પસંદ કરો.

**Options :**

86435117931. ફક્ત (A)

86435117932. ફક્ત (B)

86435117933. ફક્ત (A), (B)

86435117934. **§§¶ (A), (C)**

**Question Number : 37 Question Id : 8643515977 Question Type : MCQ Option Shuffling : Yes Is Question Mandatory : No**

**Correct Marks : 4 Wrong Marks : 1**

**Match List - I with List - II :**

<b>List - I</b>	<b>List - II</b>
(a) Be	(i) treatment of cancer
(b) Mg	(ii) extraction of metals
(c) Ca	(iii) incendiary bombs and signals
(d) Ra	(iv) windows of X-ray tubes
	(v) bearings for motor engines.

**Choose the most appropriate answer from the option given below :**

**Options :**

86435117935. (a)-(iv), (b)-(iii), (c)-(ii), (d)-(i)

86435117936. (a)-(iii), (b)-(iv), (c)-(ii), (d)-(v)

86435117937. (a)-(iv), (b)-(iii), (c)-(i), (d)-(ii)

86435117938. (a)-(iii), (b)-(iv), (c)-(v), (d)-(ii)

**Question Number : 37 Question Id : 8643515977 Question Type : MCQ Option Shuffling : Yes Is Question Mandatory : No**

**Correct Marks : 4 Wrong Marks : 1**

સૂચિ - I સાથે સૂચિ - II ને જોડો.

સૂચિ - I	સૂચિ - II
(a) Be	(i) કેન્સરનો ઉપચાર
(b) Mg	(ii) ધાતુઓનું નિષ્કર્ષણ
(c) Ca	(iii) દહનકારી બોમ્બ અને સંકેતો (incendiary bombs and signals)
(d) Ra	(iv) X-કિરણ નળીની બારી (સ્લિટ)
	(v) મોટર એન્જિનો માટે બેરીંગ

નીચે આપેલા વિકલ્પોમાંથી સૌથી વધુ બંધબેસતો જવાબ પસંદ કરો.

**Options :**

86435117935. (a)-(iv), (b)-(iii), (c)-(ii), (d)-(i)

86435117936. (a)-(iii), (b)-(iv), (c)-(ii), (d)-(v)

86435117937. (a)-(iv), (b)-(iii), (c)-(i), (d)-(ii)

86435117938. (a)-(iii), (b)-(iv), (c)-(v), (d)-(ii)

**Question Number : 38 Question Id : 8643515978 Question Type : MCQ Option Shuffling : Yes Is Question Mandatory : No**

**Correct Marks : 4 Wrong Marks : 1**

The oxidation states of nitrogen in NO, NO<sub>2</sub>, N<sub>2</sub>O and NO<sub>3</sub><sup>-</sup> are in the order of :

**Options :**

86435117939. NO > NO<sub>2</sub> > N<sub>2</sub>O > NO<sub>3</sub><sup>-</sup>

86435117940. N<sub>2</sub>O > NO<sub>2</sub> > NO > NO<sub>3</sub><sup>-</sup>

86435117941. NO<sub>2</sub> > NO<sub>3</sub><sup>-</sup> > NO > N<sub>2</sub>O

86435117942. NO<sub>3</sub><sup>-</sup> > NO<sub>2</sub> > NO > N<sub>2</sub>O

**Question Number : 38 Question Id : 8643515978 Question Type : MCQ Option Shuffling : Yes Is Question Mandatory : No**

**Correct Marks : 4 Wrong Marks : 1**

NO, NO<sub>2</sub>, N<sub>2</sub>O અને NO<sub>3</sub><sup>-</sup> માં નાઈટ્રોજનની ઓક્સિડેશન અવસ્થા ક્રમમાં શોધો.

**Options :**

86435117939. NO > NO<sub>2</sub> > N<sub>2</sub>O > NO<sub>3</sub><sup>-</sup>

86435117940. N<sub>2</sub>O > NO<sub>2</sub> > NO > NO<sub>3</sub><sup>-</sup>

86435117941. NO<sub>2</sub> > NO<sub>3</sub><sup>-</sup> > NO > N<sub>2</sub>O

86435117942. NO<sub>3</sub><sup>-</sup> > NO<sub>2</sub> > NO > N<sub>2</sub>O

**Question Number : 39 Question Id : 8643515979 Question Type : MCQ Option Shuffling : Yes Is Question Mandatory : No**

**Correct Marks : 4 Wrong Marks : 1**

The oxide that shows magnetic property is :

**Options :**

86435117943. SiO<sub>2</sub>

86435117944. Mn<sub>3</sub>O<sub>4</sub>

86435117945. MgO

86435117946. Na<sub>2</sub>O

**Question Number : 39 Question Id : 8643515979 Question Type : MCQ Option Shuffling : Yes Is Question Mandatory : No**

**Correct Marks : 4 Wrong Marks : 1**

એક ઓક્સાઈડ કે જે ચુંબકીય ગુણધર્મ પ્રદર્શિત કરે છે તે શોધો.

**Options :**

86435117943. SiO<sub>2</sub>

86435117944. Mn<sub>3</sub>O<sub>4</sub>

86435117945. MgO

86435117946. Na<sub>2</sub>O

**Question Number : 40 Question Id : 8643515980 Question Type : MCQ Option Shuffling : Yes Is Question Mandatory : No**

**Correct Marks : 4 Wrong Marks : 1**

The secondary valency and the number of hydrogen bonded water molecule(s) in CuSO<sub>4</sub>·5H<sub>2</sub>O, respectively, are :

**Options :**

86435117947. 4 and 1

86435117948. 6 and 4

86435117949. 5 and 1

86435117950. 6 and 5

**Question Number : 40 Question Id : 8643515980 Question Type : MCQ Option Shuffling : Yes Is Question Mandatory : No**

**Correct Marks : 4 Wrong Marks : 1**

CuSO<sub>4</sub>·5H<sub>2</sub>O માં દ્વિતીયક સંયોજકતા અને હાઈડ્રોજન બંધવાળા પાણી અણુ(ઓ) ની સંખ્યા અનુક્રમે શોધો.

**Options :**

86435117947. 4 અને 1

86435117948. 6 અને 4

86435117949. 5 અને 1

86435117950. 6 અને 5

**Question Number : 41 Question Id : 8643515981 Question Type : MCQ Option Shuffling : Yes Is Question Mandatory : No**

**Correct Marks : 4 Wrong Marks : 1**

Given below are two statements :

**Statement I :** Non-biodegradable wastes are generated by the thermal power plants.

**Statement II :** Bio-degradable detergents leads to eutrophication.

In the light of the above statements, choose the most appropriate answer from the options given below :

**Options :**

86435117951. Both statement I and statement II are true.

86435117952. Both statement I and statement II are false.

86435117953. Statement I is true but statement II is false.

86435117954. Statement I is false but statement II is true.

**Question Number : 41 Question Id : 8643515981 Question Type : MCQ Option Shuffling : Yes Is**

**Question Mandatory : No**

**Correct Marks : 4 Wrong Marks : 1**

નીચે બે વિધાનો આપેલા છે.

**વિધાન I :** ઉષ્મીય પાવર પ્લાન્ટ માંથી જૈવ-અવિઘટનીય કચરો ઉત્પન્ન થાય છે.

**વિધાન II :** જૈવ-વિઘટનીય પ્રક્ષાલકો સુપોષણ (eutrophication) તરફ દોરી જાય છે.

ઉપરનાં વિધાનોનાં સંદર્ભમાં, નીચે આપેલા વિકલ્પોમાંથી સૌથી વધુ બંધબેસતો જવાબ પસંદ કરો.

**Options :**

86435117951. બંને વિધાન I અને વિધાન II સાચાં છે.

86435117952. બંને વિધાન I અને વિધાન II ખોટા છે.

86435117953. વિધાન I સાચું છે પણ વિધાન II ખોટું છે.

86435117954. વિધાન I ખોટું છે પણ વિધાન II સાચું છે.

**Question Number : 42 Question Id : 8643515982 Question Type : MCQ Option Shuffling : Yes Is**

**Question Mandatory : No**

**Correct Marks : 4 Wrong Marks : 1**

Given below are two statements :

**Statement I :**  $C_2H_5OH$  and  $AgCN$  both can generate nucleophile.

**Statement II :**  $KCN$  and  $AgCN$  both will generate nitrile nucleophile with all reaction conditions.

Choose the most appropriate option :

**Options :**

86435117955. Both statement I and statement II are true.

86435117956. Both statement I and statement II are false.

86435117957. Statement I is true but statement II is false.

86435117958. Statement I is false but statement II is true.

**Question Number : 42 Question Id : 8643515982 Question Type : MCQ Option Shuffling : Yes Is**

**Question Mandatory : No**

**Correct Marks : 4 Wrong Marks : 1**

નીચે બે વિધાનો આપેલા છે.

**વિધાન I :**  $C_2H_5OH$  અને  $AgCN$  બંને કેન્દ્રાનુરાગીનું નિર્માણ કરે છે.

**વિધાન II :** બધી પ્રક્રિયા પરિસ્થિતિઓ સાથે  $KCN$  અને  $AgCN$  બંને નાઈટ્રાઈલ કેન્દ્રાનુરાગીનું નિર્માણ કરે છે.

સૌથી વધુ બંધબેસતો વિકલ્પ પસંદ કરો.

**Options :**

86435117955. બંને વિધાન I અને વિધાન II સાચાં છે.

86435117956. બંને વિધાન I અને વિધાન II ખોટા છે.

86435117957. વિધાન I સાચું છે પણ વિધાન II ખોટું છે.

86435117958. વિધાન I ખોટું છે પણ વિધાન II સાચું છે.

**Question Number : 43 Question Id : 8643515983 Question Type : MCQ Option Shuffling : Yes Is**

**Question Mandatory : No**

**Correct Marks : 4 Wrong Marks : 1**

In the following molecule,

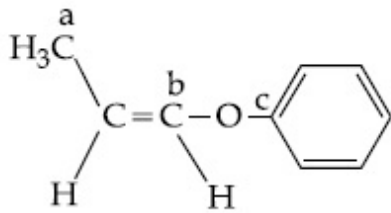

Hybridisation of Carbon a, b and c respectively are :

Options :

86435117959.  $sp^3, sp^2, sp^2$

86435117960.  $sp^3, sp^2, sp$

86435117961.  $sp^3, sp, sp$

86435117962.  $sp^3, sp, sp^2$

Question Number : 43 Question Id : 8643515983 Question Type : MCQ Option Shuffling : Yes Is Question Mandatory : No

Correct Marks : 4 Wrong Marks : 1

નીચે આપેલા અણુમાં,

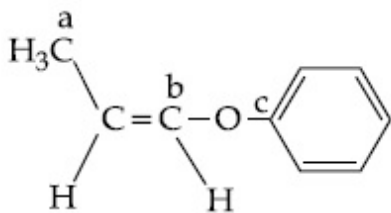

કાર્બન a, b અને c નું સંકરણ અનુક્રમે શોધો.

Options :

86435117959.  $sp^3, sp^2, sp^2$

86435117960.  $sp^3, sp^2, sp$

86435117961.  $sp^3, sp, sp$

86435117962.  $sp^3, sp, sp^2$



Question Number : 44 Question Id : 8643515984 Question Type : MCQ Option Shuffling : Yes Is Question Mandatory : No

Correct Marks : 4 Wrong Marks : 1

Main Products formed during a reaction of 1-methoxy naphthalene with hydroiodic acid are :

Options :

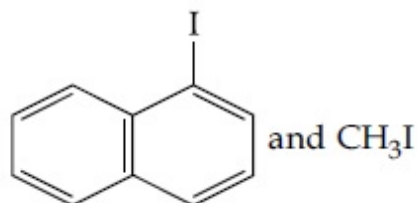

86435117963.

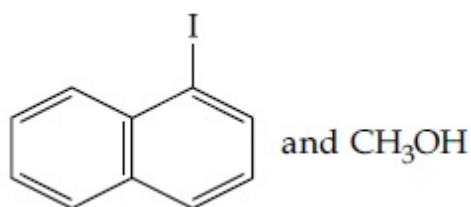

86435117964.

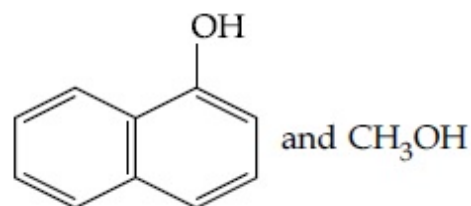

86435117965.

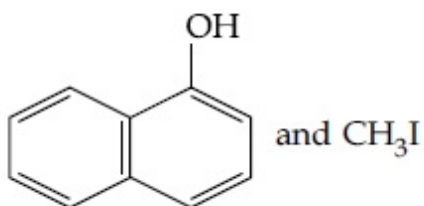

86435117966.

Question Number : 44 Question Id : 8643515984 Question Type : MCQ Option Shuffling : Yes Is Question Mandatory : No

Correct Marks : 4 Wrong Marks : 1

1-મિથોક્સી નેપ્થેલીન સાથેની હાઈડ્રો આયોડિક એસિડની પ્રક્રિયા ઇદરમ્યાન બનતી મુખ્ય નીપજો શોધો.

Options :

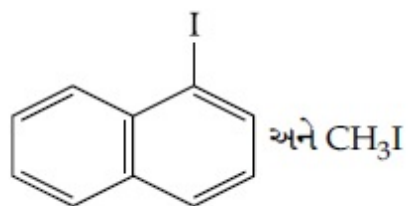

86435117963.

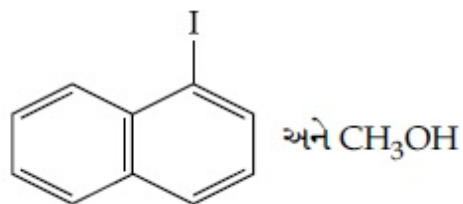

86435117964.

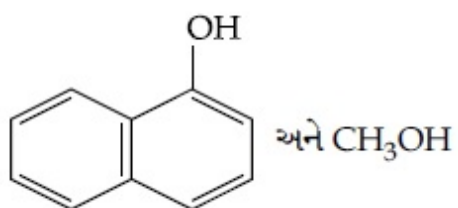

86435117965.

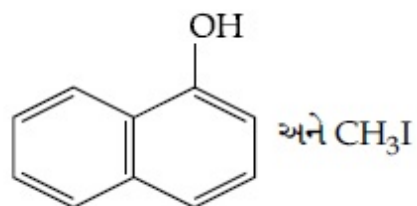

86435117966.

**Question Number : 45 Question Id : 8643515985 Question Type : MCQ Option Shuffling : Yes Is Question Mandatory : No**

**Correct Marks : 4 Wrong Marks : 1**

In the reaction of hypobromite with amide, the carbonyl carbon is lost as :

**Options :**

86435117967.  $\text{CO}$ 86435117968.  $\text{CO}_2$ 86435117969.  $\text{CO}_3^{2-}$ 86435117970.  $\text{HCO}_3^-$

Question Number : 45 Question Id : 8643515985 Question Type : MCQ Option Shuffling : Yes Is

Question Mandatory : No

Correct Marks : 4 Wrong Marks : 1

હાઈપોબ્રોમાઈટ સાથે એમાઈડની પ્રક્રિયામાં, કાર્બોનીલ કાર્બન એક તરફે દૂર થાય છે તે :

Options :

86435117967. CO

86435117968. CO<sub>2</sub>

86435117969. CO<sub>3</sub><sup>2-</sup>

86435117970. HCO<sub>3</sub><sup>-</sup>

Question Number : 46 Question Id : 8643515986 Question Type : MCQ Option Shuffling : Yes Is

Question Mandatory : No

Correct Marks : 4 Wrong Marks : 1

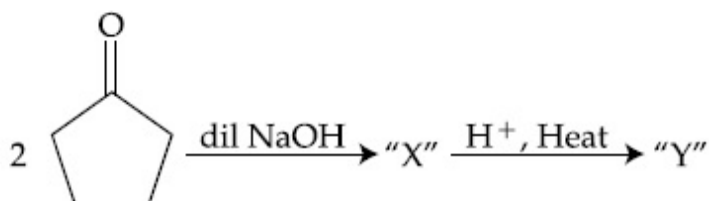

Consider the above reaction, the product 'X' and 'Y' respectively are :

Options :

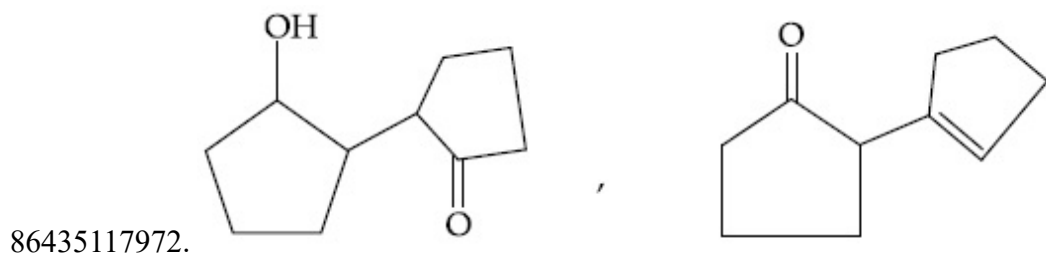
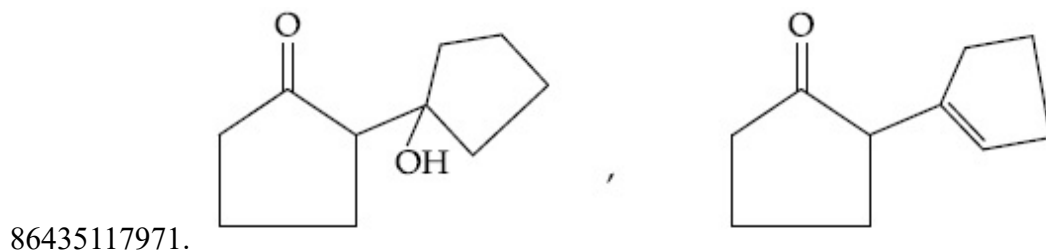

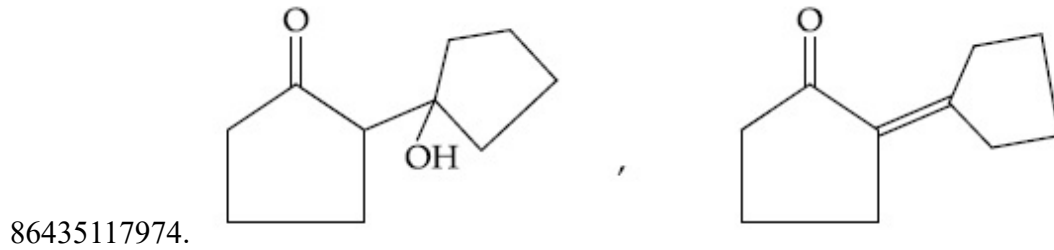
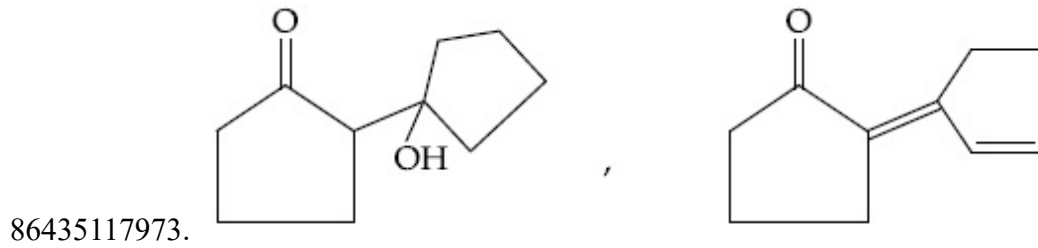

Question Number : 46 Question Id : 8643515986 Question Type : MCQ Option Shuffling : Yes Is Question Mandatory : No Correct Marks : 4 Wrong Marks : 1

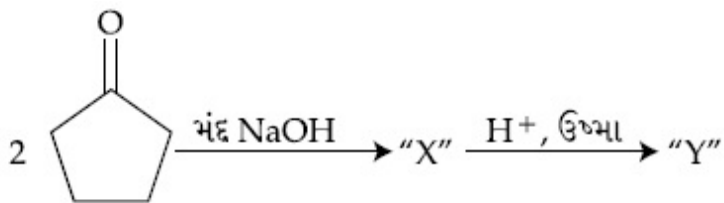

ઉપરની પ્રક્રિયાને ધ્યાનમાં લો. નીચે 'X' અને 'Y' અનુક્રમે શોધો.

Options :

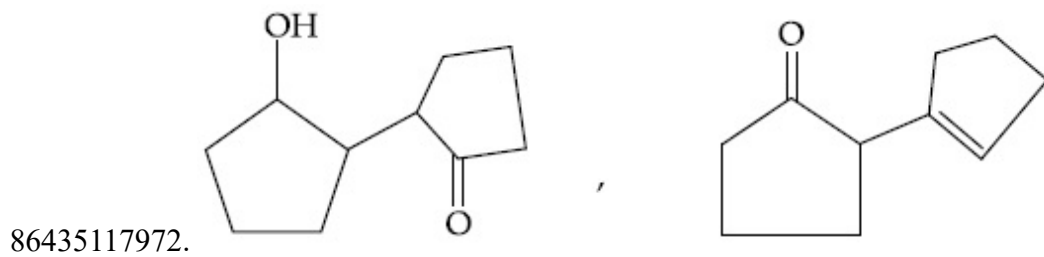
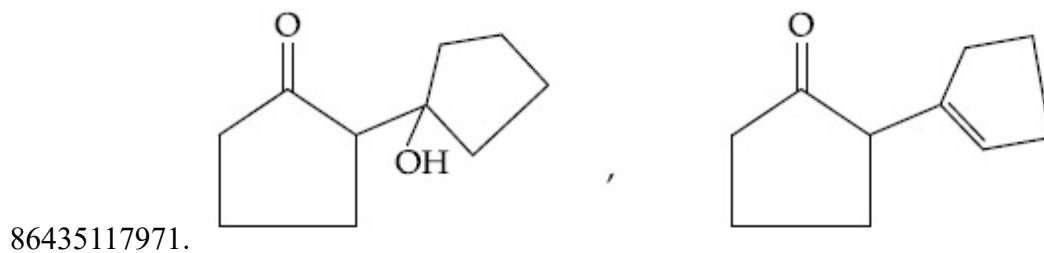

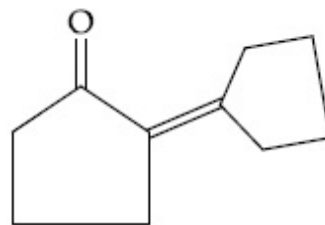
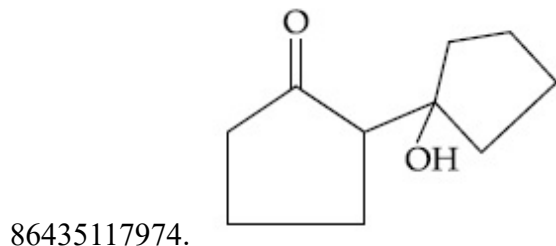
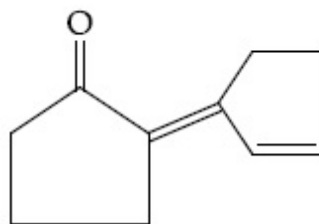
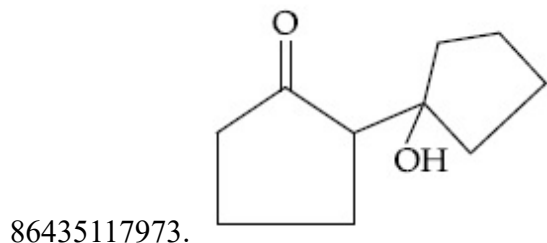

**Question Number : 47 Question Id : 8643515987 Question Type : MCQ Option Shuffling : Yes Is Question Mandatory : No**

**Correct Marks : 4 Wrong Marks : 1**

An organic compound "A" on treatment with benzene sulphonyl chloride gives compound B. B is soluble in dil. NaOH solution. Compound A is :

**Options :**

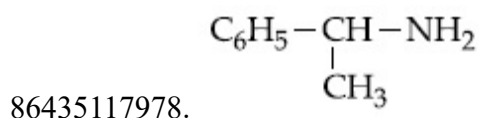
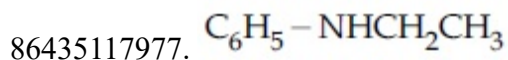
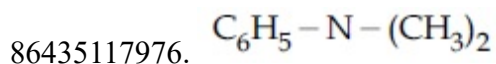
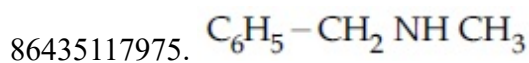

**Question Number : 47 Question Id : 8643515987 Question Type : MCQ Option Shuffling : Yes Is Question Mandatory : No**

**Correct Marks : 4 Wrong Marks : 1**

એક કાર્બનિક સંયોજન "A" ની બેન્ઝિન સલ્ફોનાઈલ ક્લોરાઈડ સાથે પ્રક્રિયા કરતાં સંયોજન B આપે છે. B એ મંદ NaOH ના દ્રાવણમાં દ્રાવ્ય થાય છે. સંયોજન A શોધો.

**Options :**

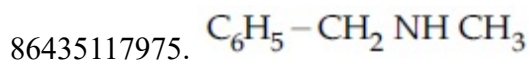

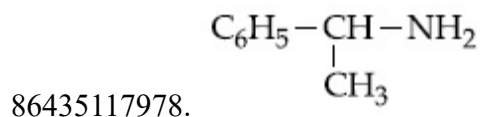
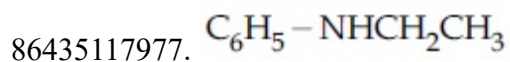
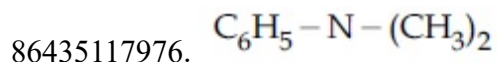

Question Number : 48 Question Id : 8643515988 Question Type : MCQ Option Shuffling : Yes Is Question Mandatory : No

Correct Marks : 4 Wrong Marks : 1

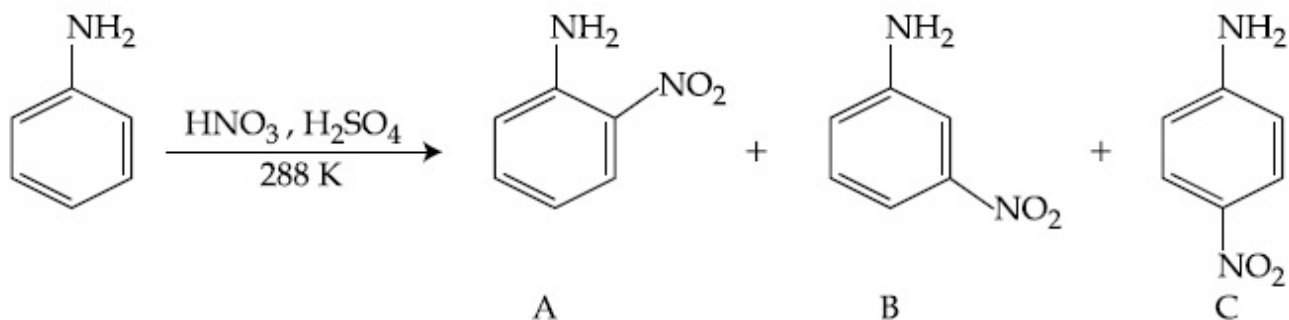

Consider the given reaction, percentage yield of :

Options :

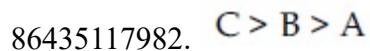
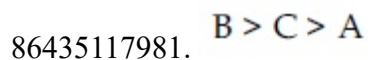
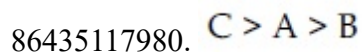
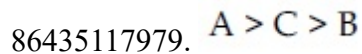

Question Number : 48 Question Id : 8643515988 Question Type : MCQ Option Shuffling : Yes Is Question Mandatory : No

Correct Marks : 4 Wrong Marks : 1

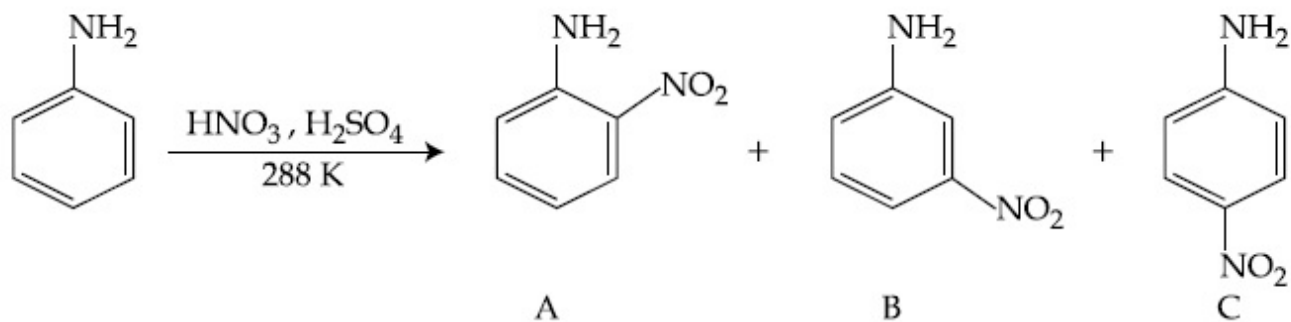

આપેલ પ્રક્રિયાને ધ્યાનમાં લો. નીચેજ ટકાવારી શોધો.

**Options :**

86435117979. A > C > B

86435117980. C > A > B

86435117981. B > C > A

86435117982. C > B > A

**Question Number : 49 Question Id : 8643515989 Question Type : MCQ Option Shuffling : Yes Is**

**Question Mandatory : No**

**Correct Marks : 4 Wrong Marks : 1**

**Match List - I with List - II :**

List - I (Class of Chemicals)	List - II (Example)
(a) Antifertility drug	(i) Meprobamate
(b) Antibiotic	(ii) Alitame
(c) Tranquilizer	(iii) Norethindrone
(d) Artificial Sweetener	(iv) Salvarsan

Choose the most appropriate match :

**Options :**

86435117983. (a)-(iv), (b)-(iii), (c)-(ii), (d)-(i)

86435117984. (a)-(ii), (b)-(iii), (c)-(iv), (d)-(i)

86435117985. (a)-(iii), (b)-(iv), (c)-(i), (d)-(ii)

86435117986. (a)-(ii), (b)-(iv), (c)-(i), (d)-(iii)

**Question Number : 49 Question Id : 8643515989 Question Type : MCQ Option Shuffling : Yes Is Question Mandatory : No**

**Correct Marks : 4 Wrong Marks : 1**

સૂચિ - I સાથે સૂચિ - II ને જોડો.

સૂચિ - I	સૂચિ - II
(રસાયણોનો વર્ગ)	(ઉદાહરણ)
(a) ગર્ભનિરોધક ઔષધ	(i) મેપ્રોબામેટ
(b) પ્રતિજીવીઓ	(ii) એલિટેમ
(c) પ્રશાંતકો	(iii) નોરએથિન્ડ્રોન
(d) કૃત્રિમ ગળ્યા પદાર્થ	(iv) સાલ્વરસેન

સૌથી વધુ અંધબેસતો વિકલ્પ પસંદ કરો.

**Options :**

86435117983. (a)-(iv), (b)-(iii), (c)-(ii), (d)-(i)

86435117984. (a)-(ii), (b)-(iii), (c)-(iv), (d)-(i)

86435117985. (a)-(iii), (b)-(iv), (c)-(i), (d)-(ii)

86435117986. (a)-(ii), (b)-(iv), (c)-(i), (d)-(iii)

**Question Number : 50 Question Id : 8643515990 Question Type : MCQ Option Shuffling : Yes Is Question Mandatory : No**

**Correct Marks : 4 Wrong Marks : 1**

Deficiency of vitamin K causes :

**Options :**

86435117987. Increase in blood clotting time

86435117988. Decrease in blood clotting time

86435117989. Cheilosis



86435117990. Increase in fragility of RBC's

**Question Number : 50 Question Id : 8643515990 Question Type : MCQ Option Shuffling : Yes Is Question Mandatory : No**

**Correct Marks : 4 Wrong Marks : 1**

વિટામીન K ની ઊણપનાં કારણે થાય તે \_\_\_\_\_

**Options :**

86435117987. લોહી જામવાનાં (ગંઠાઈ) સમયમાં વધારો

86435117988. લોહી જામવાનાં સમયમાં ઘટાડો

86435117989. કાઈલોસીસ (Cheilosis)

86435117990. RBC નાં તૂટવામાં વધારો

## Chemistry Section B

<b>Section Id :</b>	864351400
<b>Section Number :</b>	4
<b>Section type :</b>	Online
<b>Mandatory or Optional :</b>	Mandatory
<b>Number of Questions :</b>	10
<b>Number of Questions to be attempted :</b>	5
<b>Section Marks :</b>	20
<b>Mark As Answered Required? :</b>	Yes
<b>Sub-Section Number :</b>	1
<b>Sub-Section Id :</b>	864351400
<b>Question Shuffling Allowed :</b>	Yes

**Question Number : 51 Question Id : 8643515991 Question Type : SA Correct Marks : 4 Wrong Marks : 0**

10.0 mL of  $\text{Na}_2\text{CO}_3$  solution is titrated against 0.2 M HCl solution. The following titre values were obtained in 5 readings :

4.8 mL, 4.9 mL, 5.0 mL, 5.0 mL and 5.0 mL.

Based on these readings, and convention of titrimetric estimation the concentration of  $\text{Na}_2\text{CO}_3$  solution is \_\_\_\_\_ mM.

(Round off to the Nearest Integer).

**Response Type :** Numeric

**Evaluation Required For SA :** Yes

**Show Word Count :** Yes

**Answers Type :** Equal

**Text Areas :** PlainText

**Possible Answers :**

100

**Question Number :** 51 **Question Id :** 8643515991 **Question Type :** SA

**Correct Marks :** 4 **Wrong Marks :** 0

10.0 mL  $\text{Na}_2\text{CO}_3$  નાં દ્રાવણ વિરુદ્ધ 0.2 M HCl નાં દ્રાવણનું અનુમાપન કરવામાં આવે છે. નીચે પ્રમાણે અનુમાપિત મૂલ્યોનાં 5 માપનો (reading) મેળવવામાં આવ્યા.

4.8 mL, 4.9 mL, 5.0 mL, 5.0 mL અને 5.0 mL.

આ માપનો ને આધારે અને અનુમાપિત પરિમાપન ની પરંપરા પરથી  $\text{Na}_2\text{CO}_3$  દ્રાવણની સાંદ્રતા \_\_\_\_\_ mM થશે.

**Response Type :** Numeric

**Evaluation Required For SA :** Yes

**Show Word Count :** Yes

**Answers Type :** Equal

**Text Areas :** PlainText

**Possible Answers :**

100

**Question Number :** 52 **Question Id :** 8643515992 **Question Type :** SA

**Correct Marks :** 4 **Wrong Marks :** 0

The number of species below that have two lone pairs of electrons in their central atom is \_\_\_\_\_. (Round off to the Nearest Integer).

$\text{SF}_4$ ,  $\text{BF}_4^-$ ,  $\text{ClF}_3$ ,  $\text{AsF}_3$ ,  $\text{PCl}_5$ ,  $\text{BrF}_5$ ,  $\text{XeF}_4$ ,  $\text{SF}_6$

**Response Type :** Numeric

**Evaluation Required For SA :** Yes

**Show Word Count :** Yes

Answers Type : Equal

Text Areas : PlainText

Possible Answers :

100

Question Number : 52 Question Id : 8643515992 Question Type : SA

Correct Marks : 4 Wrong Marks : 0

જેમાં મધ્યસ્થ પરમાણુ બે અબંધકારક ઈલેક્ટ્રોનનાં યુગ્મો ધરાવે છે તેવા નીચે આપેલ આણુઓની સંખ્યા \_\_\_\_\_ છે. (નજીકનાં પૂર્ણાંકમાં રાઉન્ડ ઓફ કરો)

$SF_4$ ,  $BF_4^-$ ,  $ClF_3$ ,  $AsF_3$ ,  $PCl_5$ ,  $BrF_5$ ,  $XeF_4$ ,  $SF_6$

Response Type : Numeric

Evaluation Required For SA : Yes

Show Word Count : Yes

Answers Type : Equal

Text Areas : PlainText

Possible Answers :

100

Question Number : 53 Question Id : 8643515993 Question Type : SA

Correct Marks : 4 Wrong Marks : 0

The gas phase reaction



at 400 K has  $\Delta G^\circ = +25.2 \text{ kJ mol}^{-1}$ .

The equilibrium constant  $K_C$  for this reaction is \_\_\_\_\_  $\times 10^{-2}$ . (Round off to the Nearest Integer).

[Use :  $R = 8.3 \text{ J mol}^{-1} \text{ K}^{-1}$ ,  $\ln 10 = 2.3$

$\log_{10} 2 = 0.30$ ,  $1 \text{ atm} = 1 \text{ bar}$ ]

[antilog  $(-0.3) = 0.501$ ]

Response Type : Numeric

Evaluation Required For SA : Yes

Show Word Count : Yes

Answers Type : Equal

Text Areas : PlainText

Possible Answers :

100

Question Number : 53 Question Id : 8643515993 Question Type : SA

Correct Marks : 4 Wrong Marks : 0

વાયુ અવસ્થા પ્રક્રિયા

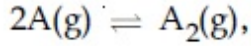

400 K પર  $\Delta G^\circ = +25.2 \text{ kJ mol}^{-1}$  છે.

આ પ્રક્રિયા માટે સંતુલન અચળાંક  $K_C$  \_\_\_\_\_  $\times 10^{-2}$  છે. (નજીકનાં પૂર્ણાંકમાં રાઉન્ડ ઓફ કરો)

[ઉપયોગ :  $R = 8.3 \text{ J mol}^{-1} \text{ K}^{-1}$ ,  $\ln 10 = 2.3$

$\log_{10} 2 = 0.30$ ,  $1 \text{ atm} = 1 \text{ bar}$ ]

[એન્ટીલોગ  $(-0.3) = 0.501$ ]

**Response Type :** Numeric

**Evaluation Required For SA :** Yes

**Show Word Count :** Yes

**Answers Type :** Equal

**Text Areas :** PlainText

**Possible Answers :**

100

**Question Number :** 54 **Question Id :** 8643515994 **Question Type :** SA

**Correct Marks :** 4 **Wrong Marks :** 0

A solute A dimerizes in water. The boiling point of a 2 molal solution of A is  $100.52^\circ\text{C}$ . The percentage association of A is \_\_\_\_\_. (Round off to the Nearest Integer).

[Use :  $K_b$  for water =  $0.52 \text{ K kg mol}^{-1}$

Boiling point of water =  $100^\circ\text{C}$ ]

**Response Type :** Numeric

**Evaluation Required For SA :** Yes

**Show Word Count :** Yes

**Answers Type :** Equal

**Text Areas :** PlainText

**Possible Answers :**

100

**Question Number :** 54 **Question Id :** 8643515994 **Question Type :** SA

**Correct Marks :** 4 **Wrong Marks :** 0

એક દ્રાવ્ય A નો પાણીમાં ડાયમર બને છે. A નાં 2 મોલલ દ્રાવણનું ઉત્કલનબિંદુ  $100.52^\circ\text{C}$  છે. તો A નું ટકાવારી સંયોજન \_\_\_\_\_ છે. (નજીકનાં પૂર્ણાંકમાં રાઉન્ડ ઓફ કરો)

[ઉપયોગ : પાણી માટે  $K_b = 0.52 \text{ K kg mol}^{-1}$

પાણીનું ઉત્કલનબિંદુ =  $100^\circ\text{C}$ ]

**Response Type :** Numeric

**Evaluation Required For SA :** Yes

**Show Word Count :** Yes

**Answers Type :** Equal

**Text Areas :** PlainText

**Possible Answers :**

100

**Question Number : 55 Question Id : 8643515995 Question Type : SA**

**Correct Marks : 4 Wrong Marks : 0**

The solubility of  $\text{CdSO}_4$  in water is  $8.0 \times 10^{-4} \text{ mol L}^{-1}$ . Its solubility in  $0.01 \text{ M H}_2\text{SO}_4$  solution is \_\_\_\_\_  $\times 10^{-6} \text{ mol L}^{-1}$ . (Round off to the Nearest Integer).

(Assume that solubility is much less than  $0.01 \text{ M}$ )

**Response Type :** Numeric

**Evaluation Required For SA :** Yes

**Show Word Count :** Yes

**Answers Type :** Equal

**Text Areas :** PlainText

**Possible Answers :**

100

**Question Number : 55 Question Id : 8643515995 Question Type : SA**

**Correct Marks : 4 Wrong Marks : 0**

$\text{CdSO}_4$  ની પાણીમાં દ્રાવ્યતાં  $8.0 \times 10^{-4} \text{ mol L}^{-1}$  છે. તો તેની  $0.01 \text{ M H}_2\text{SO}_4$  દ્રાવણમાં દ્રાવ્યતાં \_\_\_\_\_  $\times 10^{-6} \text{ mol L}^{-1}$  છે. (નજીકનાં પૂર્ણાંકમાં રાઉન્ડ ઓફ કરો)

(ધારી તો કે દ્રાવ્યતાં  $0.01 \text{ M}$  કરતાં પણ ખૂબ જ ઓછી છે)

**Response Type :** Numeric

**Evaluation Required For SA :** Yes

**Show Word Count :** Yes

**Answers Type :** Equal

**Text Areas :** PlainText

**Possible Answers :**

100

**Question Number : 56 Question Id : 8643515996 Question Type : SA**

**Correct Marks : 4 Wrong Marks : 0**

The molar conductivities at infinite dilution of barium chloride, sulphuric acid and hydrochloric acid are 280, 860 and 426 S cm<sup>2</sup> mol<sup>-1</sup> respectively. The molar conductivity at infinite dilution of barium sulphate is \_\_\_\_\_ S cm<sup>2</sup> mol<sup>-1</sup>. (Round off to the Nearest Integer).

**Response Type :** Numeric

**Evaluation Required For SA :** Yes

**Show Word Count :** Yes

**Answers Type :** Equal

**Text Areas :** PlainText

**Possible Answers :**

100

**Question Number : 56 Question Id : 8643515996 Question Type : SA**

**Correct Marks : 4 Wrong Marks : 0**

બેરિયમ ક્લોરાઇડ, સલ્ફ્યુરિક એસિડ અને હાઇડ્રોક્લોરીક એસિડની અનંત મંદતા એ મોલર વાહકતાઓ અનુક્રમે 280, 860 અને 426 S cm<sup>2</sup> mol<sup>-1</sup> છે. તો અનંત મંદતાએ બેરિયમ સલ્ફેટની મોલર વાહકતા \_\_\_\_\_ S cm<sup>2</sup> mol<sup>-1</sup> છે. (નજીકનાં પૂર્ણાંકમાં રાઉન્ડ ઓફ કરો)

**Response Type :** Numeric

**Evaluation Required For SA :** Yes

**Show Word Count :** Yes

**Answers Type :** Equal

**Text Areas :** PlainText

**Possible Answers :**

100

**Question Number : 57 Question Id : 8643515997 Question Type : SA**

**Correct Marks : 4 Wrong Marks : 0**

A reaction has a half life of 1 min. The time required for 99.9% completion of the reaction is \_\_\_\_\_ min. (Round off to the Nearest Integer).

[Use : ln 2 = 0.69; ln 10 = 2.3]

**Response Type :** Numeric

**Evaluation Required For SA :** Yes

**Show Word Count :** Yes

**Answers Type :** Equal

**Text Areas :** PlainText

**Possible Answers :**

100

**Question Number : 57 Question Id : 8643515997 Question Type : SA**

**Correct Marks : 4 Wrong Marks : 0**

એક પ્રક્રિયા 1 min. નો અર્ધ આયુષ્ય ધરાવે છે. તો પ્રક્રિયાને 99.9% પૂરી થવા માટે લાગતો જરૂરી સમય \_\_\_\_\_ min. છે. (નજીકનાં પૂર્ણાંકમાં રાઉન્ડ ઓફ કરો)

[ઉપયોગ :  $\ln 2 = 0.69$ ;  $\ln 10 = 2.3$ ]

**Response Type : Numeric**

**Evaluation Required For SA : Yes**

**Show Word Count : Yes**

**Answers Type : Equal**

**Text Areas : PlainText**

**Possible Answers :**

100

**Question Number : 58 Question Id : 8643515998 Question Type : SA**

**Correct Marks : 4 Wrong Marks : 0**

A xenon compound 'A' upon partial hydrolysis gives  $\text{XeO}_2\text{F}_2$ . The number of lone pair of electrons present in compound A is \_\_\_\_\_. (Round off to the Nearest Integer)

**Response Type : Numeric**

**Evaluation Required For SA : Yes**

**Show Word Count : Yes**

**Answers Type : Equal**

**Text Areas : PlainText**

**Possible Answers :**

100

**Question Number : 58 Question Id : 8643515998 Question Type : SA**

**Correct Marks : 4 Wrong Marks : 0**

એક ઝેનોન સંયોજન 'A' નું આંશિક જળવિભાજન કરતાં તે  $\text{XeO}_2\text{F}_2$  આપે છે. તો સંયોજન A માં હાજર ઈલેક્ટ્રોનનાં અબંધકારક યુગ્મોની સંખ્યા \_\_\_\_\_ છે. (પૂર્ણાંક જવાબ)

**Response Type : Numeric**

**Evaluation Required For SA : Yes**

**Show Word Count : Yes**

**Answers Type : Equal**

**Text Areas : PlainText**

**Possible Answers :**

100

**Question Number : 59 Question Id : 8643515999 Question Type : SA**

**Correct Marks : 4 Wrong Marks : 0**

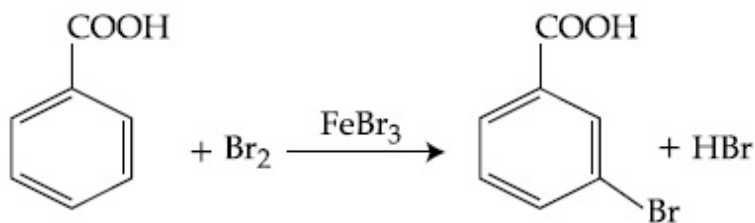

Consider the above reaction where 6.1 g of Benzoic acid is used to get 7.8 g of m-bromo benzoic acid. The percentage yield of the product is \_\_\_\_\_.

(Round off to the Nearest Integer).

[Given : Atomic masses : C : 12.0 u, H : 1.0 u, O : 16.0 u, Br : 80.0 u]

**Response Type :** Numeric

**Evaluation Required For SA :** Yes

**Show Word Count :** Yes

**Answers Type :** Equal

**Text Areas :** PlainText

**Possible Answers :**

100

**Question Number :** 59 **Question Id :** 8643515999 **Question Type :** SA

**Correct Marks :** 4 **Wrong Marks :** 0

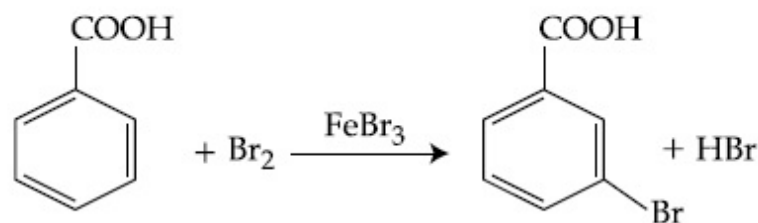

ઉપરની પ્રક્રિયાને ધ્યાનમાં લો. 7.8 g m-બ્રોમો બેન્ઝોઈક મેળવવા માટે 6.1 g બેન્ઝોઈકનો ઉપયોગ કરવામાં આવ્યો. નીપજની ટકાવારી નીપજ \_\_\_\_\_ છે. (નજીકનાં પૂર્ણાંકમાં રાઉન્ડ ઓફ કરો)

[પરમાણ્વીય દળ : C : 12.0 u, H : 1.0 u, O : 16.0 u, Br : 80.0 u]

**Response Type :** Numeric

**Evaluation Required For SA :** Yes

**Show Word Count :** Yes

**Answers Type :** Equal

**Text Areas :** PlainText

**Possible Answers :**

100

**Question Number :** 60 **Question Id :** 8643516000 **Question Type :** SA

**Correct Marks :** 4 **Wrong Marks :** 0



In Tollen's test for aldehyde, the overall number of electron(s) transferred to the Tollen's reagent formula  $[\text{Ag}(\text{NH}_3)_2]^+$  per aldehyde group to form silver mirror is \_\_\_\_\_.  
(Round off to the Nearest Integer).

**Response Type :** Numeric

**Evaluation Required For SA :** Yes

**Show Word Count :** Yes

**Answers Type :** Equal

**Text Areas :** PlainText

**Possible Answers :**

100

**Question Number :** 60 **Question Id :** 8643516000 **Question Type :** SA

**Correct Marks :** 4 **Wrong Marks :** 0

આલ્ડીહાઈડ માટે ટોલેન્સ કસોટીમાં, રજત દર્પણ બનવા માટે ટોલેન્સ પ્રક્રિયક સૂત્ર  $[\text{Ag}(\text{NH}_3)_2]^+$  માં સ્થળાંતર (પરિવહન) થતાં ઇલેક્ટ્રોન(નો) ની સમગ્ર સંખ્યા પર આલ્ડીહાઈડ સમૂહ \_\_\_\_\_ છે.

**Response Type :** Numeric

**Evaluation Required For SA :** Yes

**Show Word Count :** Yes

**Answers Type :** Equal

**Text Areas :** PlainText

**Possible Answers :**

100

## Mathematics Section A

<b>Section Id :</b>	864351401
<b>Section Number :</b>	5
<b>Section type :</b>	Online
<b>Mandatory or Optional :</b>	Mandatory
<b>Number of Questions :</b>	20
<b>Number of Questions to be attempted :</b>	20
<b>Section Marks :</b>	80
<b>Mark As Answered Required? :</b>	Yes
<b>Sub-Section Number :</b>	1
<b>Sub-Section Id :</b>	864351401
<b>Question Shuffling Allowed :</b>	Yes

**Question Number :** 61 **Question Id :** 8643516001 **Question Type :** MCQ **Option Shuffling :** Yes **Is**

**Question Mandatory :** No

**Correct Marks :** 4 **Wrong Marks :** 1

If  $15\sin^4\alpha + 10\cos^4\alpha = 6$ , for some  $\alpha \in \mathbb{R}$ , then the value of  $27\sec^6\alpha + 8\operatorname{cosec}^6\alpha$  is equal to :

**Options :**

86435118001. 500

86435118002. 400

86435118003. 350

86435118004. 250

**Question Number : 61 Question Id : 8643516001 Question Type : MCQ Option Shuffling : Yes Is Question Mandatory : No**

**Correct Marks : 4 Wrong Marks : 1**

કોઈ  $\alpha \in \mathbb{R}$  માટે, જો  $15\sin^4\alpha + 10\cos^4\alpha = 6$  હોય, તો  $27\sec^6\alpha + 8\operatorname{cosec}^6\alpha$  નું મૂલ્ય \_\_\_\_\_ છે.

**Options :**

86435118001. 500

86435118002. 400

86435118003. 350

86435118004. 250

**Question Number : 62 Question Id : 8643516002 Question Type : MCQ Option Shuffling : Yes Is Question Mandatory : No**

**Correct Marks : 4 Wrong Marks : 1**

If P and Q are two statements, then which of the following compound statement is a tautology ?

**Options :**

86435118005.  $((P \Rightarrow Q) \wedge \sim Q) \Rightarrow P$

86435118006.  $((P \Rightarrow Q) \wedge \sim Q) \Rightarrow Q$

86435118007.  $((P \Rightarrow Q) \wedge \sim Q) \Rightarrow \sim P$

86435118008.  $((P \Rightarrow Q) \wedge \sim Q) \Rightarrow (P \wedge Q)$

**Question Number : 62 Question Id : 8643516002 Question Type : MCQ Option Shuffling : Yes Is Question Mandatory : No**

**Correct Marks : 4 Wrong Marks : 1**

જો P અને Q બે વિધાનો હોય, તો નીચેનામાંથી કયું મિશ્ર વિધાન નિત્યસત્ય છે ?

**Options :**

86435118005.  $((P \Rightarrow Q) \wedge \sim Q) \Rightarrow P$

86435118006.  $((P \Rightarrow Q) \wedge \sim Q) \Rightarrow Q$

86435118007.  $((P \Rightarrow Q) \wedge \sim Q) \Rightarrow \sim P$

86435118008.  $((P \Rightarrow Q) \wedge \sim Q) \Rightarrow (P \wedge Q)$

**Question Number : 63 Question Id : 8643516003 Question Type : MCQ Option Shuffling : Yes Is Question Mandatory : No**

**Correct Marks : 4 Wrong Marks : 1**

A pole stands vertically inside a triangular park ABC. Let the angle of elevation of the top of the pole from each corner of the park be  $\frac{\pi}{3}$ . If the radius of the circumcircle of  $\Delta ABC$  is 2,

then the height of the pole is equal to :

**Options :**

86435118009.  $\frac{2\sqrt{3}}{3}$

86435118010.  $2\sqrt{3}$

86435118011.  $\frac{1}{\sqrt{3}}$

86435118012.  $\sqrt{3}$

**Question Number : 63 Question Id : 8643516003 Question Type : MCQ Option Shuffling : Yes Is Question Mandatory : No**

**Correct Marks : 4 Wrong Marks : 1**

ત્રિકોણાકાર બાજુ ABC ની અંદર એક થાંભલો લંબ સ્થિતિમાં છે. ધારો કે બાજુનાં દરેક ખૂણા પરથી થાંભલાની ટોચનો ઉત્સેધ કોણ  $\frac{\pi}{3}$  છે. જો  $\Delta ABC$  નાં પરિવૃત્તની ત્રિજ્યા 2 હોય, તો થાંભલાની ઊંચાઈ \_\_\_\_\_ છે.

**Options :**

86435118009.  $\frac{2\sqrt{3}}{3}$

86435118010.  $2\sqrt{3}$

86435118011.  $\frac{1}{\sqrt{3}}$

86435118012.  $\sqrt{3}$

**Question Number : 64 Question Id : 8643516004 Question Type : MCQ Option Shuffling : Yes Is**

**Question Mandatory : No**

**Correct Marks : 4 Wrong Marks : 1**

Let in a series of  $2n$  observations, half of them are equal to  $a$  and remaining half are equal to  $-a$ . Also by adding a constant  $b$  in each of these observations, the mean and standard deviation of new set become 5 and 20, respectively. Then the value of  $a^2 + b^2$  is equal to :

**Options :**

86435118013. 925

86435118014. 425

86435118015. 650

86435118016. 250

**Question Number : 64 Question Id : 8643516004 Question Type : MCQ Option Shuffling : Yes Is**

**Question Mandatory : No**

**Correct Marks : 4 Wrong Marks : 1**

ધારો કે  $2n$  અવલોકનોની શ્રેણીમાંના અડધા બરાબર  $a$  છે અને બાકીનાં અડધા બરાબર  $-a$  છે. વળી આ દરેક અવલોકનોમાં અચળ  $b$  ઉમેરતાં નવા ગણનાં મધ્યક તથા પ્રમાણિત વિચલન અનુક્રમે 5 અને 20 બને છે. તો  $a^2 + b^2$  નું મૂલ્ય \_\_\_\_\_ થાય.

**Options :**

86435118013. 925

86435118014. 425

86435118015. 650

86435118016. 250

**Question Number : 65 Question Id : 8643516005 Question Type : MCQ Option Shuffling : Yes Is Question Mandatory : No**

**Correct Marks : 4 Wrong Marks : 1**

Let in a Binomial distribution, consisting of 5 independent trials, probabilities of exactly 1 and 2 successes be 0.4096 and 0.2048 respectively. Then the probability of getting exactly 3 successes is equal to :

**Options :**

86435118017.  $\frac{40}{243}$

86435118018.  $\frac{80}{243}$

86435118019.  $\frac{128}{625}$

86435118020.  $\frac{32}{625}$

**Question Number : 65 Question Id : 8643516005 Question Type : MCQ Option Shuffling : Yes Is Question Mandatory : No**

**Correct Marks : 4 Wrong Marks : 1**

5 નિરપેક્ષ પ્રયત્નો સમાવતા દ્વિપદી વિતરણમાં ધારો કે બરાબર 1 અને 2 સફળતાની સંભાવનાઓ અનુક્રમે 0.4096 અને 0.2048 છે. તો બરાબર 3 સફળતા મળવાની સંભાવના \_\_\_\_\_ છે.

**Options :**

86435118017.  $\frac{40}{243}$

$$86435118018. \frac{80}{243}$$

$$86435118019. \frac{128}{625}$$

$$86435118020. \frac{32}{625}$$

**Question Number : 66 Question Id : 8643516006 Question Type : MCQ Option Shuffling : Yes Is Question Mandatory : No Correct Marks : 4 Wrong Marks : 1**

In a triangle ABC, if  $|\vec{BC}| = 8$ ,  $|\vec{CA}| = 7$ ,  $|\vec{AB}| = 10$ , then the projection of the vector  $\vec{AB}$  on  $\vec{AC}$  is equal to :

**Options :**

$$86435118021. \frac{115}{16}$$

$$86435118022. \frac{85}{14}$$

$$86435118023. \frac{127}{20}$$

$$86435118024. \frac{25}{4}$$

**Question Number : 66 Question Id : 8643516006 Question Type : MCQ Option Shuffling : Yes Is Question Mandatory : No Correct Marks : 4 Wrong Marks : 1**

ત્રિકોણ ABC માં જો  $|\vec{BC}| = 8$ ,  $|\vec{CA}| = 7$  અને  $|\vec{AB}| = 10$  હોય, તો સદિશ  $\vec{AB}$  નાં  $\vec{AC}$  પરનું પ્રક્ષેપ \_\_\_\_\_ છે.

**Options :**

$$86435118021. \frac{115}{16}$$

$$86435118022. \frac{85}{14}$$

$$86435118023. \frac{127}{20}$$

$$86435118024. \frac{25}{4}$$

**Question Number : 67 Question Id : 8643516007 Question Type : MCQ Option Shuffling : Yes Is Question Mandatory : No**

**Correct Marks : 4 Wrong Marks : 1**

Let the centroid of an equilateral triangle ABC be at the origin. Let one of the sides of the equilateral triangle be along the straight line  $x + y = 3$ . If R and r be the radius of circumcircle and incircle respectively of  $\Delta ABC$ , then  $(R + r)$  is equal to :

**Options :**

$$86435118025. 2\sqrt{2}$$

$$86435118026. \frac{9}{\sqrt{2}}$$

$$86435118027. 7\sqrt{2}$$

$$86435118028. 3\sqrt{2}$$

**Question Number : 67 Question Id : 8643516007 Question Type : MCQ Option Shuffling : Yes Is Question Mandatory : No**

**Correct Marks : 4 Wrong Marks : 1**

ધારો કે સમબાજુ ત્રિકોણ ABC નું મધ્યકેન્દ્ર ઊગમબિંદુ પર છે. ધારો કે સમબાજુ ત્રિકોણની એક બાજુ સુરેખા  $x + y = 3$  ને સમાંતર આવેલ છે. જો R અને r એ  $\Delta ABC$  નાં અનુક્રમે પરિવૃત્ત તથા અંતઃવૃત્તની ત્રિજ્યા હોય, તો  $(R + r) =$

\_\_\_\_\_.

**Options :**

86435118025.  $2\sqrt{2}$

86435118026.  $\frac{9}{\sqrt{2}}$

86435118027.  $7\sqrt{2}$

86435118028.  $3\sqrt{2}$

**Question Number : 68 Question Id : 8643516008 Question Type : MCQ Option Shuffling : Yes Is Question Mandatory : No**

**Correct Marks : 4 Wrong Marks : 1**

Let a tangent be drawn to the ellipse  $\frac{x^2}{27} + y^2 = 1$  at  $(3\sqrt{3}\cos\theta, \sin\theta)$  where  $\theta \in \left(0, \frac{\pi}{2}\right)$ .

Then the value of  $\theta$  such that the sum of intercepts on axes made by this tangent is minimum

is equal to :

**Options :**

86435118029.  $\frac{\pi}{3}$

86435118030.  $\frac{\pi}{6}$

86435118031.  $\frac{\pi}{8}$

86435118032.  $\frac{\pi}{4}$

**Question Number : 68 Question Id : 8643516008 Question Type : MCQ Option Shuffling : Yes Is Question Mandatory : No**

**Correct Marks : 4 Wrong Marks : 1**



ધારો કે  $(3\sqrt{3}\cos\theta, \sin\theta)$ , જ્યાં  $\theta \in \left(0, \frac{\pi}{2}\right)$ , પાસે ઉપલલય  $\frac{x^2}{27} + y^2 = 1$  ને સ્પર્શક દોરવામાં આવે છે. તો આ સ્પર્શક દ્વારા અક્ષો સાથે બનાવેલ અંતઃખંડોનો સરવાળો ન્યૂનતમ થાય તેવી  $\theta$  કિંમત \_\_\_\_\_ છે.

**Options :**

86435118029.  $\frac{\pi}{3}$

86435118030.  $\frac{\pi}{6}$

86435118031.  $\frac{\pi}{8}$

86435118032.  $\frac{\pi}{4}$

**Question Number : 69 Question Id : 8643516009 Question Type : MCQ Option Shuffling : Yes Is Question Mandatory : No**

**Correct Marks : 4 Wrong Marks : 1**

Let  $y = y(x)$  be the solution of the differential equation  $\frac{dy}{dx} = (y + 1) \left( (y + 1)e^{x^{2/2} - x} \right)$ ,

$0 < x < 2.1$ , with  $y(2) = 0$ . Then the value of  $\frac{dy}{dx}$  at  $x = 1$  is equal to :

**Options :**

86435118033.  $\frac{e^{5/2}}{(1 + e^2)^2}$

86435118034.  $-\frac{2e^2}{(1 + e^2)^2}$

86435118035.  $\frac{5e^{1/2}}{(e^2 + 1)^2}$

$$\frac{-e^{3/2}}{(e^2 + 1)^2}$$

86435118036.

**Question Number : 69 Question Id : 8643516009 Question Type : MCQ Option Shuffling : Yes Is Question Mandatory : No**

**Correct Marks : 4 Wrong Marks : 1**

ધારો કે  $y = y(x)$  એ વિકલ સમીકરણ  $\frac{dy}{dx} = (y + 1) \left( (y + 1)e^{x^2/2} - x \right)$ ,  $0 < x < 2.1$  નો ઉકેલ છે, જ્યાં

$y(2) = 0$ . તો  $x = 1$  પાસે  $\frac{dy}{dx}$  નું મૂલ્ય \_\_\_\_\_ છે.

**Options :**

$$\frac{e^{5/2}}{(1 + e^2)^2}$$

86435118033.

$$-\frac{2e^2}{(1 + e^2)^2}$$

86435118034.

$$\frac{5e^{1/2}}{(e^2 + 1)^2}$$

86435118035.

$$\frac{-e^{3/2}}{(e^2 + 1)^2}$$

86435118036.

**Question Number : 70 Question Id : 8643516010 Question Type : MCQ Option Shuffling : Yes Is Question Mandatory : No**

**Correct Marks : 4 Wrong Marks : 1**

The area bounded by the curve  $4y^2 = x^2(4 - x)(x - 2)$  is equal to :

**Options :**

$$\frac{3\pi}{8}$$

86435118037.

$$86435118038. \frac{\pi}{16}$$

$$86435118039. \frac{\pi}{8}$$

$$86435118040. \frac{3\pi}{2}$$

**Question Number : 70 Question Id : 8643516010 Question Type : MCQ Option Shuffling : Yes Is Question Mandatory : No**

**Correct Marks : 4 Wrong Marks : 1**

વક્ર  $4y^2 = x^2(4-x)(x-2)$  દ્વારા સીમિત ક્ષેત્રફળ \_\_\_\_\_ છે.

**Options :**

$$86435118037. \frac{3\pi}{8}$$

$$86435118038. \frac{\pi}{16}$$

$$86435118039. \frac{\pi}{8}$$

$$86435118040. \frac{3\pi}{2}$$

**Question Number : 71 Question Id : 8643516011 Question Type : MCQ Option Shuffling : Yes Is Question Mandatory : No**

**Correct Marks : 4 Wrong Marks : 1**

Let  $g(x) = \int_0^x f(t)dt$ , where  $f$  is continuous function in  $[0, 3]$  such that  $\frac{1}{3} \leq f(t) \leq 1$  for all

$t \in [0, 1]$  and  $0 \leq f(t) \leq \frac{1}{2}$  for all  $t \in (1, 3]$ . The largest possible interval in which  $g(3)$  lies is :

**Options :**

$$86435118041. \left[ \frac{1}{3}, 2 \right]$$

$$\left[-1, -\frac{1}{2}\right]$$

86435118042.

$$[1, 3]$$

86435118043.

$$\left[-\frac{3}{2}, -1\right]$$

86435118044.

**Question Number : 71 Question Id : 8643516011 Question Type : MCQ Option Shuffling : Yes Is Question Mandatory : No**

**Correct Marks : 4 Wrong Marks : 1**

ધારો કે  $g(x) = \int_0^x f(t)dt$ , જ્યાં  $f$  એ  $[0, 3]$  માં એવું સતત વિધેય છે કે જેથી દરેક  $t \in [0, 1]$  માટે  $\frac{1}{3} \leq f(t) \leq 1$

અને દરેક  $t \in (1, 3]$  માટે  $0 \leq f(t) \leq \frac{1}{2}$ . તો  $g(3)$  ને સમાવતો મોટામાં મોટો શક્ય અંતરાલ \_\_\_\_\_ છે.

**Options :**

$$\left[\frac{1}{3}, 2\right]$$

86435118041.

$$\left[-1, -\frac{1}{2}\right]$$

86435118042.

$$[1, 3]$$

86435118043.

$$\left[-\frac{3}{2}, -1\right]$$

86435118044.

**Question Number : 72 Question Id : 8643516012 Question Type : MCQ Option Shuffling : Yes Is Question Mandatory : No**

**Correct Marks : 4 Wrong Marks : 1**

Let  $f: \mathbb{R} \rightarrow \mathbb{R}$  be a function defined as

$$f(x) = \begin{cases} \frac{\sin(a+1)x + \sin 2x}{2x}, & \text{if } x < 0 \\ b, & \text{if } x = 0 \\ \frac{\sqrt{x + bx^3} - \sqrt{x}}{bx^{5/2}}, & \text{if } x > 0 \end{cases}$$

If  $f$  is continuous at  $x=0$ , then the value of  $a+b$  is equal to :

Options :

86435118045.  $-\frac{5}{2}$

86435118046.  $-3$

86435118047.  $-2$

86435118048.  $-\frac{3}{2}$

Question Number : 72 Question Id : 8643516012 Question Type : MCQ Option Shuffling : Yes Is Question Mandatory : No

Correct Marks : 4 Wrong Marks : 1

ધારો કે વિધેય  $f: \mathbb{R} \rightarrow \mathbb{R}$

$$f(x) = \begin{cases} \frac{\sin(a+1)x + \sin 2x}{2x}, & \text{જો } x < 0 \\ b, & \text{જો } x = 0 \\ \frac{\sqrt{x + bx^3} - \sqrt{x}}{bx^{5/2}}, & \text{જો } x > 0 \end{cases}$$

પ્રમાણે વ્યાખ્યાયિત છે. જો  $x=0$  પાસે  $f$  સતત હોય, તો  $a+b$  નું મૂલ્ય \_\_\_\_\_ છે.

Options :

$$86435118045. \quad -\frac{5}{2}$$

$$86435118046. \quad -3$$

$$86435118047. \quad -2$$

$$86435118048. \quad -\frac{3}{2}$$

**Question Number : 73 Question Id : 8643516013 Question Type : MCQ Option Shuffling : Yes Is Question Mandatory : No**

**Correct Marks : 4 Wrong Marks : 1**

Let  $S_1$  be the sum of first  $2n$  terms of an arithmetic progression. Let  $S_2$  be the sum of first  $4n$  terms of the same arithmetic progression. If  $(S_2 - S_1)$  is 1000, then the sum of the first  $6n$  terms of the arithmetic progression is equal to :

**Options :**

$$86435118049. \quad 7000$$

$$86435118050. \quad 5000$$

$$86435118051. \quad 3000$$

$$86435118052. \quad 1000$$

**Question Number : 73 Question Id : 8643516013 Question Type : MCQ Option Shuffling : Yes Is Question Mandatory : No**

**Correct Marks : 4 Wrong Marks : 1**

ધારો કે સમાંતર શ્રેણીનાં પ્રથમ  $2n$  પદોનો સરવાળો  $S_1$  છે. ધારો કે આજ સમાંતર શ્રેણીનાં પ્રથમ  $4n$  પદોનો સરવાળો  $S_2$  છે. જો  $(S_2 - S_1)$  એ 1000 હોય, તો સમાંતર શ્રેણીનાં પ્રથમ  $6n$  પદોનો સરવાળો \_\_\_\_\_ થાય.

**Options :**

$$86435118049. \quad 7000$$

$$86435118050. \quad 5000$$

$$86435118051. \quad 3000$$

86435118052. 1000

**Question Number : 74 Question Id : 8643516014 Question Type : MCQ Option Shuffling : Yes Is Question Mandatory : No**

**Correct Marks : 4 Wrong Marks : 1**

Let  $S_1 : x^2 + y^2 = 9$  and  $S_2 : (x - 2)^2 + y^2 = 1$ . Then the locus of center of a variable circle  $S$  which touches  $S_1$  internally and  $S_2$  externally always passes through the points :

**Options :**

86435118053.  $\left(2, \pm \frac{3}{2}\right)$

86435118054.  $(0, \pm \sqrt{3})$

86435118055.  $(1, \pm 2)$

86435118056.  $\left(\frac{1}{2}, \pm \frac{\sqrt{5}}{2}\right)$

**Question Number : 74 Question Id : 8643516014 Question Type : MCQ Option Shuffling : Yes Is Question Mandatory : No**

**Correct Marks : 4 Wrong Marks : 1**

ધારો કે  $S_1 : x^2 + y^2 = 9$  અને  $S_2 : (x - 2)^2 + y^2 = 1$ . તો  $S_1$  ને અંતઃસ્પર્શી તથા  $S_2$  ને બાહ્ય સ્પર્શી ચલ વર્તુળ  $S$  નાં કેન્દ્રનો બિંદુપથ હંમેશા બિંદુઓ \_\_\_\_\_ માંથી પસાર થશે.

**Options :**

86435118053.  $\left(2, \pm \frac{3}{2}\right)$

86435118054.  $(0, \pm \sqrt{3})$

86435118055.  $(1, \pm 2)$

$$\left(\frac{1}{2}, \pm \frac{\sqrt{5}}{2}\right)$$

86435118056.

**Question Number : 75 Question Id : 8643516015 Question Type : MCQ Option Shuffling : Yes Is Question Mandatory : No**

**Correct Marks : 4 Wrong Marks : 1**

Let the system of linear equations

$$4x + \lambda y + 2z = 0$$

$$2x - y + z = 0$$

$$\mu x + 2y + 3z = 0, \lambda, \mu \in \mathbb{R}.$$

has a non-trivial solution. Then which of the following is true ?

**Options :**

86435118057.  $\lambda = 3, \mu \in \mathbb{R}$

86435118058.  $\mu = -6, \lambda \in \mathbb{R}$

86435118059.  $\lambda = 2, \mu \in \mathbb{R}$

86435118060.  $\mu = 6, \lambda \in \mathbb{R}$

**Question Number : 75 Question Id : 8643516015 Question Type : MCQ Option Shuffling : Yes Is Question Mandatory : No**

**Correct Marks : 4 Wrong Marks : 1**

ધારો કે સુરેખ સમીકરણ સંહતી

$$4x + \lambda y + 2z = 0$$

$$2x - y + z = 0$$

$$\mu x + 2y + 3z = 0, \lambda, \mu \in \mathbb{R}$$

ને અસાહજિક ઉકેલો છે. તો નીચેનામાંથી કયું સાચું છે ?

**Options :**

86435118057.  $\lambda = 3, \mu \in \mathbb{R}$

86435118058.  $\mu = -6, \lambda \in \mathbb{R}$

86435118059.  $\lambda = 2, \mu \in \mathbb{R}$



86435118060.  $\mu = 6, \lambda \in \mathbb{R}$

**Question Number : 76 Question Id : 8643516016 Question Type : MCQ Option Shuffling : Yes Is Question Mandatory : No**

**Correct Marks : 4 Wrong Marks : 1**

Let  $f: \mathbb{R} - \{3\} \rightarrow \mathbb{R} - \{1\}$  be defined by  $f(x) = \frac{x-2}{x-3}$ .

Let  $g: \mathbb{R} \rightarrow \mathbb{R}$  be given as  $g(x) = 2x - 3$ . Then, the sum of all the values of  $x$  for which

$f^{-1}(x) + g^{-1}(x) = \frac{13}{2}$  is equal to.

**Options :**

86435118061. 2

86435118062. 5

86435118063. 3

86435118064. 7

**Question Number : 76 Question Id : 8643516016 Question Type : MCQ Option Shuffling : Yes Is Question Mandatory : No**

**Correct Marks : 4 Wrong Marks : 1**

ધારો કે  $f: \mathbb{R} - \{3\} \rightarrow \mathbb{R} - \{1\}$  એ  $f(x) = \frac{x-2}{x-3}$  પ્રમાણે વ્યાખ્યાયિત છે. ધારો કે

$g: \mathbb{R} \rightarrow \mathbb{R}$  એ  $g(x) = 2x - 3$  પ્રમાણે આપેલ છે. તો  $f^{-1}(x) + g^{-1}(x) = \frac{13}{2}$  થાય તેવી  $x$  ની તમામ કિંમતોનો

સરવાળો \_\_\_\_\_ છે.

**Options :**

86435118061. 2

86435118062. 5

86435118063. 3

86435118064. 7

**Question Number : 77 Question Id : 8643516017 Question Type : MCQ Option Shuffling : Yes Is Question Mandatory : No Correct Marks : 4 Wrong Marks : 1**

Let a complex number be  $w = 1 - \sqrt{3}i$ . Let another complex number  $z$  be such that  $|zw| = 1$  and  $\arg(z) - \arg(w) = \frac{\pi}{2}$ . Then the area of the triangle with vertices origin,  $z$  and  $w$  is equal

to :

**Options :**

86435118065.  $\frac{1}{2}$

86435118066. 2

86435118067.  $\frac{1}{4}$

86435118068. 4

**Question Number : 77 Question Id : 8643516017 Question Type : MCQ Option Shuffling : Yes Is Question Mandatory : No Correct Marks : 4 Wrong Marks : 1**

ધારો કે  $w = 1 - \sqrt{3}i$  સંકર સંખ્યા છે. ધારો કે અન્ય સંકર સંખ્યા  $z$  એવી છે કે જેથી  $|zw| = 1$  અને  $\arg(z) - \arg(w) = \frac{\pi}{2}$  થાય. તો ઊગમબિંદુ,  $z$  અને  $w$  શિરોબિંદુઓ વાળા ત્રિકોણનું ક્ષેત્રફળ \_\_\_\_\_ થાય.

**Options :**

86435118065.  $\frac{1}{2}$

86435118066. 2

86435118067.  $\frac{1}{4}$

86435118068. 4

**Question Number : 78 Question Id : 8643516018 Question Type : MCQ Option Shuffling : Yes Is Question Mandatory : No**

**Correct Marks : 4 Wrong Marks : 1**

Define a relation R over a class of  $n \times n$  real matrices A and B as

“ARB iff there exists a non-singular matrix P such that  $PAP^{-1} = B$ ”.

Then which of the following is true ?

**Options :**

86435118069. R is reflexive, symmetric but not transitive

86435118070. R is reflexive, transitive but not symmetric

86435118071. R is symmetric, transitive but not reflexive,

86435118072. R is an equivalence relation

**Question Number : 78 Question Id : 8643516018 Question Type : MCQ Option Shuffling : Yes Is Question Mandatory : No**

**Correct Marks : 4 Wrong Marks : 1**

$n \times n$  વાસ્તવિક શ્રેણિકો A અને B નાં વર્ગ પર સંબંધ R ને “ARB તો અને તો જ એવો સામાન્ય શ્રેણિક P મળે જ કે જેથી  $PAP^{-1} = B$ ” પ્રમાણે વ્યાખ્યાયિત કરવામાં આવે છે. તો નીચેનામાંથી કયું સાચું છે ?

**Options :**

86435118069. R સ્વવાચક, સંમિત છે પરંતુ પરંપરિત નથી

86435118070. R સ્વવાચક, પરંપરિત છે પરંતુ સંમિત નથી

86435118071. R સંમિત, પરંપરિત છે પરંતુ સ્વવાચક નથી

86435118072. R સામ્ય સંબંધ છે

**Question Number : 79 Question Id : 8643516019 Question Type : MCQ Option Shuffling : Yes Is Question Mandatory : No**

**Correct Marks : 4 Wrong Marks : 1**

Consider a hyperbola  $H : x^2 - 2y^2 = 4$ . Let the tangent at a point  $P (4, \sqrt{6})$  meet the  $x$ -axis at  $Q$  and latus rectum at  $R (x_1, y_1)$ ,  $x_1 > 0$ . If  $F$  is a focus of  $H$  which is nearer to the point  $P$ , then the area of  $\Delta QFR$  is equal to .

Options :

86435118073.  $\sqrt{6} - 1$

86435118074.  $\frac{7}{\sqrt{6}} - 2$

86435118075.  $4\sqrt{6} - 1$

86435118076.  $4\sqrt{6}$

Question Number : 79 Question Id : 8643516019 Question Type : MCQ Option Shuffling : Yes Is

Question Mandatory : No

Correct Marks : 4 Wrong Marks : 1

અતિવલય  $H : x^2 - 2y^2 = 4$  ગણતરીમાં લો. ધારો કે બિંદુ  $P (4, \sqrt{6})$  પાસેનો સ્પર્શક  $x$ -અક્ષ ને  $Q$  પાસે અને નાબિલંબને  $R (x_1, y_1)$ ,  $x_1 > 0$  પાસે મળે છે. જો  $F$  એ બિંદુ  $P$  થી સૌથી વધુ નજીકની  $H$  ની નાબિ લેય, તો  $\Delta QFR$  નું ક્ષેત્રફળ \_\_\_\_\_ થશે.

Options :

86435118073.  $\sqrt{6} - 1$

86435118074.  $\frac{7}{\sqrt{6}} - 2$

86435118075.  $4\sqrt{6} - 1$

86435118076.  $4\sqrt{6}$

Question Number : 80 Question Id : 8643516020 Question Type : MCQ Option Shuffling : Yes Is

Question Mandatory : No

**Correct Marks : 4 Wrong Marks : 1**

Let  $\vec{a}$  and  $\vec{b}$  be two non-zero vectors perpendicular to each other and  $|\vec{a}| = |\vec{b}|$ . If

$|\vec{a} \times \vec{b}| = |\vec{a}|$ , then the angle between the vectors  $(\vec{a} + \vec{b} + (\vec{a} \times \vec{b}))$  and  $\vec{a}$  is equal to :

**Options :**

86435118077.  $\cos^{-1}\left(\frac{1}{\sqrt{3}}\right)$

86435118078.  $\cos^{-1}\left(\frac{1}{\sqrt{2}}\right)$

86435118079.  $\sin^{-1}\left(\frac{1}{\sqrt{3}}\right)$

86435118080.  $\sin^{-1}\left(\frac{1}{\sqrt{6}}\right)$

**Question Number : 80 Question Id : 8643516020 Question Type : MCQ Option Shuffling : Yes Is Question Mandatory : No**

**Correct Marks : 4 Wrong Marks : 1**

ધારો કે  $\vec{a}$  અને  $\vec{b}$  બે શૂન્યેતર પરસ્પર લંબ સદિશો છે અને  $|\vec{a}| = |\vec{b}|$ . જો  $|\vec{a} \times \vec{b}| = |\vec{a}|$  હોય, તો સદિશો

$(\vec{a} + \vec{b} + (\vec{a} \times \vec{b}))$  અને  $\vec{a}$  વચ્ચેનો ખૂણો \_\_\_\_\_ છે.

**Options :**

86435118077.  $\cos^{-1}\left(\frac{1}{\sqrt{3}}\right)$

86435118078.  $\cos^{-1}\left(\frac{1}{\sqrt{2}}\right)$

86435118079.  $\sin^{-1}\left(\frac{1}{\sqrt{3}}\right)$

$$\sin^{-1}\left(\frac{1}{\sqrt{6}}\right)$$

86435118080.

## Mathematics Section B

Section Id :	864351402
Section Number :	6
Section type :	Online
Mandatory or Optional :	Mandatory
Number of Questions :	10
Number of Questions to be attempted :	5
Section Marks :	20
Mark As Answered Required? :	Yes
Sub-Section Number :	1
Sub-Section Id :	864351402
Question Shuffling Allowed :	Yes

Question Number : 81 Question Id : 8643516021 Question Type : SA

Correct Marks : 4 Wrong Marks : 0

If  $f(x)$  and  $g(x)$  are two polynomials such that the polynomial  $P(x) = f(x^3) + x g(x^3)$  is divisible by  $x^2 + x + 1$ , then  $P(1)$  is equal to \_\_\_\_\_.

Response Type : Numeric

Evaluation Required For SA : Yes

Show Word Count : Yes

Answers Type : Equal

Text Areas : PlainText

Possible Answers :

100

Question Number : 81 Question Id : 8643516021 Question Type : SA

Correct Marks : 4 Wrong Marks : 0

જો  $f(x)$  તથા  $g(x)$  બે એવી બહુપદીઓ હોય, જ્યાં  $P(x) = f(x^3) + x g(x^3)$  એ  $x^2 + x + 1$  વડે વિભાજ્ય થાય, તો  $P(1) =$  \_\_\_\_\_.

Response Type : Numeric

Evaluation Required For SA : Yes

Show Word Count : Yes

Answers Type : Equal

Text Areas : PlainText

Possible Answers :

100

**Question Number : 82 Question Id : 8643516022 Question Type : SA**

**Correct Marks : 4 Wrong Marks : 0**

Let I be an identity matrix of order  $2 \times 2$  and  $P = \begin{bmatrix} 2 & -1 \\ 5 & -3 \end{bmatrix}$ . Then the value of  $n \in \mathbb{N}$  for which

$P^n = 5I - 8P$  is equal to \_\_\_\_\_.

**Response Type : Numeric**

**Evaluation Required For SA : Yes**

**Show Word Count : Yes**

**Answers Type : Equal**

**Text Areas : PlainText**

**Possible Answers :**

100

**Question Number : 82 Question Id : 8643516022 Question Type : SA**

**Correct Marks : 4 Wrong Marks : 0**

ધારો કે I કક્ષા  $2 \times 2$  નો એકમ શ્રેણિક છે અને  $P = \begin{bmatrix} 2 & -1 \\ 5 & -3 \end{bmatrix}$ . તો જેના માટે  $P^n = 5I - 8P$  થાય તેવી  $n \in \mathbb{N}$  ની કિંમત \_\_\_\_\_ છે.

**Response Type : Numeric**

**Evaluation Required For SA : Yes**

**Show Word Count : Yes**

**Answers Type : Equal**

**Text Areas : PlainText**

**Possible Answers :**

100

**Question Number : 83 Question Id : 8643516023 Question Type : SA**

**Correct Marks : 4 Wrong Marks : 0**

The term independent of  $x$  in the expansion of  $\left[ \frac{x+1}{x^{2/3} - x^{1/3} + 1} - \frac{x-1}{x - x^{1/2}} \right]^{10}$ ,  $x \neq 1$ , is equal to \_\_\_\_\_.

**Response Type : Numeric**

**Evaluation Required For SA : Yes**

**Show Word Count : Yes**

**Answers Type : Equal**

**Text Areas :** PlainText

**Possible Answers :**

100

**Question Number : 83 Question Id : 8643516023 Question Type : SA**

**Correct Marks : 4 Wrong Marks : 0**

$$\left[ \frac{x+1}{x^{2/3} - x^{1/3} + 1} - \frac{x-1}{x - x^{1/2}} \right]^{10}, x \neq 1 \text{ નાં વિસ્તરણમાં } x \text{ થી નિરપેક્ષ પદ } \underline{\hspace{2cm}} \text{ છે.}$$

**Response Type :** Numeric

**Evaluation Required For SA :** Yes

**Show Word Count :** Yes

**Answers Type :** Equal

**Text Areas :** PlainText

**Possible Answers :**

100

**Question Number : 84 Question Id : 8643516024 Question Type : SA**

**Correct Marks : 4 Wrong Marks : 0**

$$\text{If } \sum_{r=1}^{10} r! (r^3 + 6r^2 + 2r + 5) = \alpha (11!),$$

then the value of  $\alpha$  is equal to \_\_\_\_\_.

**Response Type :** Numeric

**Evaluation Required For SA :** Yes

**Show Word Count :** Yes

**Answers Type :** Equal

**Text Areas :** PlainText

**Possible Answers :**

100

**Question Number : 84 Question Id : 8643516024 Question Type : SA**

**Correct Marks : 4 Wrong Marks : 0**

$$\text{જો } \sum_{r=1}^{10} r! (r^3 + 6r^2 + 2r + 5) = \alpha (11!), \text{ હોય, તો } \alpha = \underline{\hspace{2cm}}.$$

**Response Type :** Numeric

**Evaluation Required For SA :** Yes

**Show Word Count :** Yes

**Answers Type :** Equal

**Text Areas :** PlainText

**Possible Answers :**



100

**Question Number : 85 Question Id : 8643516025 Question Type : SA****Correct Marks : 4 Wrong Marks : 0**

Let  $P(x)$  be a real polynomial of degree 3 which vanishes at  $x = -3$ . Let  $P(x)$  have local

minima at  $x = 1$ , local maxima at  $x = -1$  and  $\int_{-1}^1 P(x)dx = 18$ , then the sum of all the coefficients

of the polynomial  $P(x)$  is equal to \_\_\_\_\_.

**Response Type : Numeric****Evaluation Required For SA : Yes****Show Word Count : Yes****Answers Type : Equal****Text Areas : PlainText****Possible Answers :**

100

**Question Number : 85 Question Id : 8643516025 Question Type : SA****Correct Marks : 4 Wrong Marks : 0**

ધારો કે  $P(x)$  એ 3 ઘાતવાળી અને  $x = -3$  પાસે શૂન્ય થતી વાસ્તવિક બહુપદી છે. ધારો કે  $P(x)$  ને  $x = 1$  પાસે સ્થાનિક

લઘુત્તમ (local minima),  $x = -1$  પાસે સ્થાનિક અધિકત્તમ (local maxima) હોય અને  $\int_{-1}^1 P(x)dx = 18$  હોય, તો

બહુપદી  $P(x)$  નાં તમામ સહગુણકોનો સરવાળો \_\_\_\_\_ થાય.

**Response Type : Numeric****Evaluation Required For SA : Yes****Show Word Count : Yes****Answers Type : Equal****Text Areas : PlainText****Possible Answers :**

100

**Question Number : 86 Question Id : 8643516026 Question Type : SA****Correct Marks : 4 Wrong Marks : 0**

Let  $y = y(x)$  be the solution of the differential equation  $xdy - ydx = \sqrt{(x^2 - y^2)} dx$ ,  $x \geq 1$ , with

$y(1) = 0$ . If the area bounded by the line  $x = 1$ ,  $x = e^\pi$ ,  $y = 0$  and  $y = y(x)$  is  $\alpha e^{2\pi} + \beta$ , then the value of  $10(\alpha + \beta)$  is equal to \_\_\_\_\_.

**Response Type :** Numeric

**Evaluation Required For SA :** Yes

**Show Word Count :** Yes

**Answers Type :** Equal

**Text Areas :** PlainText

**Possible Answers :**

100

**Question Number :** 86 **Question Id :** 8643516026 **Question Type :** SA

**Correct Marks :** 4 **Wrong Marks :** 0

ધારો કે  $y = y(x)$  એ વિકલ સમીકરણ  $x dy - y dx = \sqrt{(x^2 - y^2)} dx, x \geq 1$ , નો ઉકેલ છે, જ્યાં  $y(1) = 0$ . જો રેખાઓ

$x = 1, x = e^\pi, y = 0$  તથા  $y = y(x)$  થી સંવૃત્ત ક્ષેત્રફળ  $\alpha e^{2\pi} + \beta$  હોય, તો  $10(\alpha + \beta)$  નું મૂલ્ય \_\_\_\_\_ થાય.

**Response Type :** Numeric

**Evaluation Required For SA :** Yes

**Show Word Count :** Yes

**Answers Type :** Equal

**Text Areas :** PlainText

**Possible Answers :**

100

**Question Number :** 87 **Question Id :** 8643516027 **Question Type :** SA

**Correct Marks :** 4 **Wrong Marks :** 0

Let P be a plane containing the line  $\frac{x-1}{3} = \frac{y+6}{4} = \frac{z+5}{2}$  and parallel to the line

$\frac{x-3}{4} = \frac{y-2}{-3} = \frac{z+5}{7}$ . If the point  $(1, -1, \alpha)$  lies on the plane P, then the value of  $|\alpha|$  is

equal to \_\_\_\_\_.

**Response Type :** Numeric

**Evaluation Required For SA :** Yes

**Show Word Count :** Yes

**Answers Type :** Equal

**Text Areas :** PlainText

**Possible Answers :**

100

**Question Number :** 87 **Question Id :** 8643516027 **Question Type :** SA

**Correct Marks :** 4 **Wrong Marks :** 0

ધારો કે રેખા  $\frac{x-1}{3} = \frac{y+6}{4} = \frac{z+5}{2}$  ને સમાવતો અને રેખા  $\frac{x-3}{4} = \frac{y-2}{-3} = \frac{z+5}{7}$  ને સમાંતર સમતલ P છે.

જો બિંદુ  $(1, -1, \alpha)$  સમતલ P પર આવેલ હોય, તો  $|5\alpha|$  નું મૂલ્ય \_\_\_\_\_ છે.

**Response Type :** Numeric

**Evaluation Required For SA :** Yes

**Show Word Count :** Yes

**Answers Type :** Equal

**Text Areas :** PlainText

**Possible Answers :**

100

**Question Number :** 88 **Question Id :** 8643516028 **Question Type :** SA

**Correct Marks :** 4 **Wrong Marks :** 0

Let the mirror image of the point  $(1, 3, a)$  with respect to the plane  $\vec{r} \cdot (2\hat{i} - \hat{j} + \hat{k}) - b = 0$  be  $(-3, 5, 2)$ . Then, the value of  $|a + b|$  is equal to \_\_\_\_\_.

**Response Type :** Numeric

**Evaluation Required For SA :** Yes

**Show Word Count :** Yes

**Answers Type :** Equal

**Text Areas :** PlainText

**Possible Answers :**

100

**Question Number :** 88 **Question Id :** 8643516028 **Question Type :** SA

**Correct Marks :** 4 **Wrong Marks :** 0

ધારો કે બિંદુ  $(1, 3, a)$  નું સમતલ  $\vec{r} \cdot (2\hat{i} - \hat{j} + \hat{k}) - b = 0$  સાપેક્ષ આરસી પ્રતિબિંબ  $(-3, 5, 2)$  છે. તો  $|a + b|$  નું મૂલ્ય \_\_\_\_\_ છે.

**Response Type :** Numeric

**Evaluation Required For SA :** Yes

**Show Word Count :** Yes

**Answers Type :** Equal

**Text Areas :** PlainText

**Possible Answers :**

100

**Question Number :** 89 **Question Id :** 8643516029 **Question Type :** SA

**Correct Marks :** 4 **Wrong Marks :** 0

Let  ${}^nC_r$  denote the binomial coefficient of  $x^r$  in the expansion of  $(1+x)^n$ .

If  $\sum_{k=0}^{10} (2^2 + 3k) {}^nC_k = \alpha \cdot 3^{10} + \beta \cdot 2^{10}$ ,  $\alpha, \beta \in \mathbb{R}$ , then  $\alpha + \beta$  is equal to \_\_\_\_\_.

**Response Type :** Numeric

**Evaluation Required For SA :** Yes

**Show Word Count :** Yes

**Answers Type :** Equal

**Text Areas :** PlainText

**Possible Answers :**

100

**Question Number :** 89 **Question Id :** 8643516029 **Question Type :** SA

**Correct Marks :** 4 **Wrong Marks :** 0

ધારો કે  $(1+x)^n$  નાં વિસ્તરણમાં  $x^r$  નો દ્વિપદી સહગુણક  ${}^nC_r$  વડે દર્શાવાય છે. જો

$\sum_{k=0}^{10} (2^2 + 3k) {}^nC_k = \alpha \cdot 3^{10} + \beta \cdot 2^{10}$ ,  $\alpha, \beta \in \mathbb{R}$  હોય તો  $\alpha + \beta =$  \_\_\_\_\_.

**Response Type :** Numeric

**Evaluation Required For SA :** Yes

**Show Word Count :** Yes

**Answers Type :** Equal

**Text Areas :** PlainText

**Possible Answers :**

100

**Question Number :** 90 **Question Id :** 8643516030 **Question Type :** SA

**Correct Marks :** 4 **Wrong Marks :** 0

Let  $f: \mathbb{R} \rightarrow \mathbb{R}$  satisfy the equation  $f(x+y) = f(x) \cdot f(y)$  for all  $x, y \in \mathbb{R}$  and  $f(x) \neq 0$  for any  $x \in \mathbb{R}$ .

If the function  $f$  is differentiable at  $x=0$  and  $f'(0)=3$ , then  $\lim_{h \rightarrow 0} \frac{1}{h} (f(h) - 1)$  is equal to

\_\_\_\_\_.

**Response Type :** Numeric

**Evaluation Required For SA :** Yes

**Show Word Count :** Yes

**Answers Type :** Equal

**Text Areas :** PlainText

**Possible Answers :**

100

**Question Number : 90 Question Id : 8643516030 Question Type : SA**

**Correct Marks : 4 Wrong Marks : 0**

દરેક  $x, y \in \mathbb{R}$  માટે ધારો કે  $f: \mathbb{R} \rightarrow \mathbb{R}$  સમીકરણ  $f(x+y) = f(x) \cdot f(y)$  નું સમાધાન કરે છે અને દરેક  $x \in \mathbb{R}$  માટે

$f(x) \neq 0$  . જો  $x=0$  પાસે વિધેય  $f$  વિકલનીય હોય અને  $f'(0) = 3$  હોય, તો  $\lim_{h \rightarrow 0} \frac{1}{h} (f(h) - 1) = \underline{\hspace{2cm}}$ .

**Response Type : Numeric**

**Evaluation Required For SA : Yes**

**Show Word Count : Yes**

**Answers Type : Equal**

**Text Areas : PlainText**

**Possible Answers :**

100