

# National Testing Agency

<b>Question Paper Name :</b>	B TECH EO 18th March 2021 Shift 2
<b>Subject Name :</b>	B TECH EO
<b>Creation Date :</b>	2021-03-18 19:51:25
<b>Duration :</b>	180
<b>Number of Questions :</b>	90
<b>Total Marks :</b>	300
<b>Display Marks:</b>	Yes

## B TECH EO

<b>Group Number :</b>	1
<b>Group Id :</b>	86435173
<b>Group Maximum Duration :</b>	0
<b>Group Minimum Duration :</b>	180
<b>Show Attended Group? :</b>	No
<b>Edit Attended Group? :</b>	No
<b>Break time :</b>	0
<b>Group Marks :</b>	300
<b>Is this Group for Examiner? :</b>	No

## Physics Section A

<b>Section Id :</b>	864351433
<b>Section Number :</b>	1
<b>Section type :</b>	Online
<b>Mandatory or Optional :</b>	Mandatory
<b>Number of Questions :</b>	20
<b>Number of Questions to be attempted :</b>	20
<b>Section Marks :</b>	80
<b>Mark As Answered Required? :</b>	Yes
<b>Sub-Section Number :</b>	1
<b>Sub-Section Id :</b>	864351433
<b>Question Shuffling Allowed :</b>	Yes

**Question Number : 1 Question Id : 8643516481 Question Type : MCQ Option Shuffling : Yes Is Question Mandatory : No Correct Marks : 4 Wrong Marks : 1**

Consider a sample of oxygen behaving like an ideal gas. At 300 K, the ratio of root mean square (rms) velocity to the average velocity of gas molecule would be :

(Molecular weight of oxygen is 32 g/mol;  $R = 8.3 \text{ J K}^{-1} \text{ mol}^{-1}$ )

Options :

$$\sqrt{\frac{3\pi}{8}}$$

86435119441.

$$\sqrt{\frac{8\pi}{3}}$$

86435119442.

$$\sqrt{\frac{8}{3}}$$

86435119443.

$$\sqrt{\frac{3}{3}}$$

86435119444.

**Question Number : 1 Question Id : 8643516481 Question Type : MCQ Option Shuffling : Yes Is Question Mandatory : No**

**Correct Marks : 4 Wrong Marks : 1**

ଆଦର୍ଶ ଗ୍ୟାସର ଆଚରଣ ଦେଖାଇଥିବା ଏକ ଅମ୍ଳଜାନ ନମୁନାକୁ ବିଚାରକୁ ନିଅ । 300 K ତାପମାତ୍ରାରେ ଗ୍ୟାସଟିର ମାଧ୍ୟବର୍ଗର ବର୍ଗମୂଳ (ଆର୍.ଏମ୍.ଏସ୍) ବେଗ ଓ ହାରାହାରି ବେଗର ଅନୁପାତ ହେବ :

(Molecular weight of oxygen is 32 g/mol;  $R = 8.3 \text{ J K}^{-1} \text{ mol}^{-1}$ )

Options :

$$\sqrt{\frac{3\pi}{8}}$$

86435119441.

$$\sqrt{\frac{8\pi}{3}}$$

86435119442.

$$\sqrt{\frac{8}{3}}$$

86435119443.

86435119444.  $\sqrt{\frac{3}{3}}$

**Question Number : 2 Question Id : 8643516482 Question Type : MCQ Option Shuffling : Yes Is Question Mandatory : No**

**Correct Marks : 4 Wrong Marks : 1**

An object of mass  $m_1$  collides with another object of mass  $m_2$ , which is at rest. After the collision the objects move with equal speeds in opposite direction. The ratio of the masses  $m_2 : m_1$  is :

**Options :**

86435119445. 1 : 1

86435119446. 1 : 2

86435119447. 2 : 1

86435119448. 3 : 1

**Question Number : 2 Question Id : 8643516482 Question Type : MCQ Option Shuffling : Yes Is Question Mandatory : No**

**Correct Marks : 4 Wrong Marks : 1**

$m_1$  ବସ୍ତୁ ବିଶିଷ୍ଟ ଗୋଟିଏ ବସ୍ତୁ ଛିର ଅବସ୍ଥାରେ ଥିବା  $m_2$  ବସ୍ତୁ ବିଶିଷ୍ଟ ଅନ୍ୟ ଏକ ବସ୍ତୁ ସହ ଧକ୍କା କରୁଛି । ଧକ୍କା ପରେ ଦୁଇଟି ଯାକ ବସ୍ତୁ ସମାନ ବେଗରେ ବିପରୀତ ଦିଗରେ ଗତି କଲେ । ସେମାନଙ୍କର ବସ୍ତୁର ଅନୁପାତ  $m_2 : m_1$  ହେଉଛି :

**Options :**

86435119445. 1 : 1

86435119446. 1 : 2

86435119447. 2 : 1

86435119448. 3 : 1

**Question Number : 3 Question Id : 8643516483 Question Type : MCQ Option Shuffling : Yes Is Question Mandatory : No**

**Correct Marks : 4 Wrong Marks : 1**

A particle of mass  $m$  moves in a circular orbit under the central potential field,  $U(r) = -\frac{C}{r}$ ,

where  $C$  is a positive constant.

The correct radius - velocity graph of the particle's motion is :

Options :

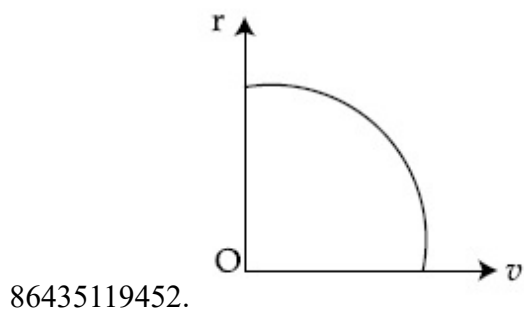
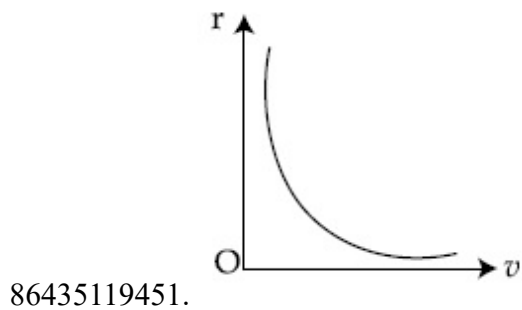
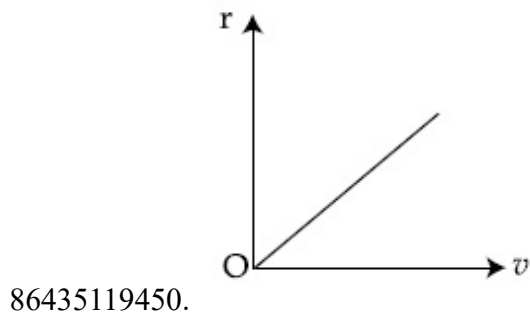
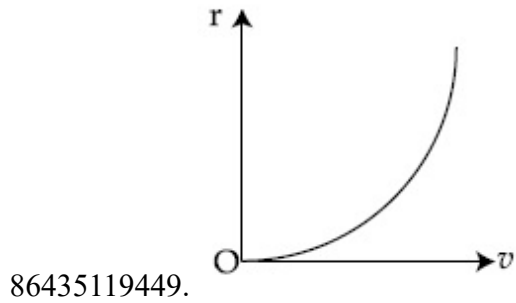

Question Number : 3 Question Id : 8643516483 Question Type : MCQ Option Shuffling : Yes Is Question Mandatory : No

Correct Marks : 4 Wrong Marks : 1

ଧନାତ୍ମକ ସ୍ଥିରାଙ୍କ  $C$  ରହିଥିବା ଗୋଟିଏ କେନ୍ଦ୍ରୀୟ ବିଭବ କ୍ଷେତ୍ର,  $U(r) = -\frac{C}{r}$  ରେ  $m$  ବସ୍ତୁର ବିଶିଷ୍ଟ ଗୋଟିଏ କଣିକାଟିର ଗତି

କରୁଅଛି ।

କଣିକାଟିର ଗତିର ସଠିକ୍ ବ୍ୟାସାଙ୍କ - ପରିବେଶ ଲେଖାଚିତ୍ରଟି ଅଟେ :

Options :

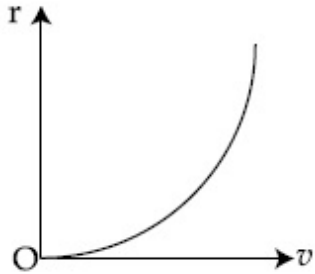

86435119449.

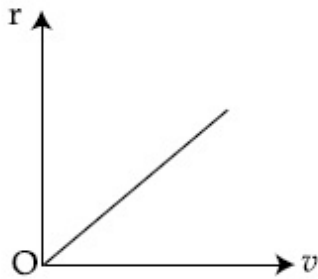

86435119450.

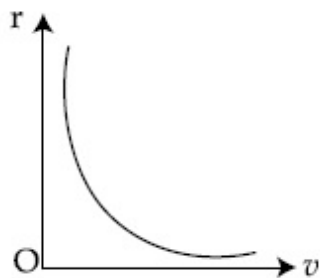

86435119451.

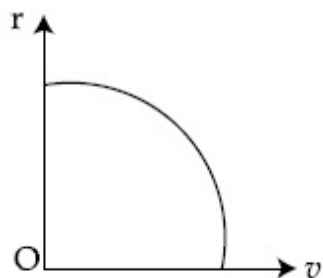

86435119452.

Question Number : 4 Question Id : 8643516484 Question Type : MCQ Option Shuffling : Yes Is

**Question Mandatory : No**

**Correct Marks : 4 Wrong Marks : 1**

A solid cylinder of mass  $m$  is wrapped with an inextensible light string and, is placed on a rough inclined plane as shown in the figure. The frictional force acting between the cylinder and the inclined plane is :

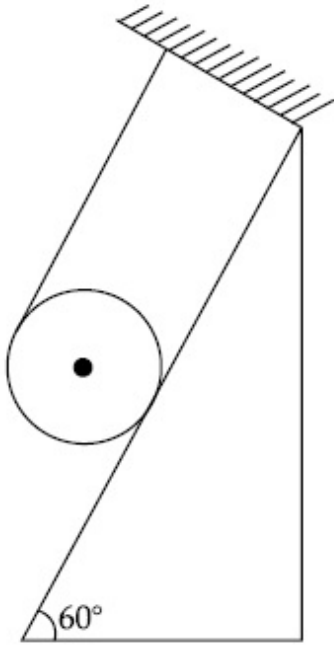

[The coefficient of static friction,  $\mu_s$ , is 0.4]

**Options :**

86435119453.  $\frac{mg}{5}$

86435119454.  $5 mg$

86435119455.  $\frac{7}{2} mg$

86435119456.  $0$

**Question Number : 4 Question Id : 8643516484 Question Type : MCQ Option Shuffling : Yes Is**

**Question Mandatory : No**

**Correct Marks : 4 Wrong Marks : 1**

ଅପ୍ରସାରଣ-କ୍ଷମ ଗୋଟିଏ ଦଉଡ଼ିରେ ଏକ  $m$  ବସ୍ତୁକୁ ବିଶିଷ୍ଟ ଏକ ନିର୍ଦ୍ଦିଷ୍ଟ ସିଲିଣ୍ଡରକୁ ଗୁଡ଼ାଯାଇଛି ଏବଂ ଚିତ୍ରରେ ଦର୍ଶାଯାଇଥିବା ଅନୁସାରେ ଏକ ଗଡ଼ାଣିଆ ବନ୍ଧୁର ସମତଳ ଉପରେ ରଖାଯାଇଛି । ସିଲିଣ୍ଡର ଓ ଗଡ଼ାଣିଆ ପୃଷ୍ଠତଳ ମଧ୍ୟରେ କାର୍ଯ୍ୟ କରୁଥିବା ଘର୍ଷଣ ବଳ ଅଟେ :

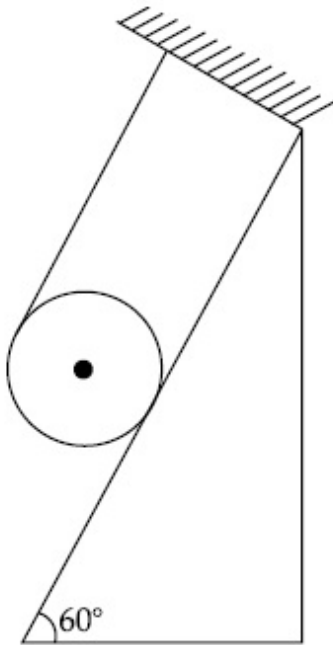

(ଘିର ଘର୍ଷଣ ସ୍ଥଳାଙ୍କ  $\mu_s = 0.4$ )

Options :

86435119453.  $\frac{mg}{5}$

86435119454.  $5 mg$

86435119455.  $\frac{7}{2} mg$

86435119456.  $0$

Question Number : 5 Question Id : 8643516485 Question Type : MCQ Option Shuffling : Yes Is

Question Mandatory : No

Correct Marks : 4 Wrong Marks : 1

If the angular velocity of earth's spin is increased such that the bodies at the equator start floating, the duration of the day would be approximately :

[Take  $g = 10 \text{ ms}^{-2}$ , the radius of earth,  $R = 6400 \times 10^3 \text{ m}$ , Take  $\pi = 3.14$ ]

Options :

86435119457. does not change

86435119458. 1200 minutes

86435119459. 60 minutes

86435119460. 84 minutes

**Question Number : 5 Question Id : 8643516485 Question Type : MCQ Option Shuffling : Yes Is Question Mandatory : No**

**Correct Marks : 4 Wrong Marks : 1**

ଯଦି ପୃଥିବୀ ଘୂର୍ଣ୍ଣନର କୌଣସିକ ବେଗକୁ ଏମିତି ବୃଦ୍ଧି କରାଗଲା ଯେମିତିକି ବିଶୁଦ୍ଧ ରେଖାରେ ଅବସ୍ଥିତ ବସ୍ତୁଗୁଡ଼ିକ ଭାସିବାକୁ ଆରମ୍ଭ କରିବେ, ତେବେ ଗୋଟିଏ ଦିନର ଅବଧି ପାଖାପାଖି ହେବ :

(ଧର  $g = 10 \text{ ms}^{-2}$ , ପୃଥିବୀର ବ୍ୟାସାର୍ଦ୍ଧ  $R = 6400 \times 10^3 \text{ m}$ ,  $\pi = 3.14$  ନିଅ)

**Options :**

86435119457. ବଦଳିବ ନାହିଁ

86435119458. 1200 ମିନିଟ୍

86435119459. 60 ମିନିଟ୍

86435119460. 84 ମିନିଟ୍

**Question Number : 6 Question Id : 8643516486 Question Type : MCQ Option Shuffling : Yes Is Question Mandatory : No**

**Correct Marks : 4 Wrong Marks : 1**

Consider a uniform wire of mass  $M$  and length  $L$ . It is bent into a semicircle. Its moment of inertia about a line perpendicular to the plane of the wire passing through the centre is :

**Options :**

86435119461.  $\frac{ML^2}{\pi^2}$

86435119462.  $\frac{1}{2} \frac{ML^2}{\pi^2}$



$$\frac{1}{4} \frac{ML^2}{\pi^2}$$

86435119463.

$$\frac{2}{5} \frac{ML^2}{\pi^2}$$

86435119464.

**Question Number : 6 Question Id : 8643516486 Question Type : MCQ Option Shuffling : Yes Is Question Mandatory : No**

**Correct Marks : 4 Wrong Marks : 1**

M ବସ୍ତୁର ଏବଂ L ଦୈର୍ଘ୍ୟ ବିଶିଷ୍ଟ ଗୋଟିଏ ଅନୁରୂପ ତାରକୁ ବିଚାରକୁ ନିଅ । ଏହାକୁ ଅର୍ଦ୍ଧବୃତ୍ତ ରୂପେ ବଳାଇ ଦିଆଯାଇଛି । ତାରଟିର ସମତଳକୁ ଲମ୍ବ ଭାବରେ ଥାଇ ଅର୍ଦ୍ଧବୃତ୍ତର କେନ୍ଦ୍ର ମଧ୍ୟ ଦେଇ ଯାଉଥିବା ଅକ୍ଷ ରାରିପଟେ ଆକ୍ଷେପିତ ଜଡ଼ତ୍ୱ ଅଟେ :

**Options :**

$$\frac{ML^2}{\pi^2}$$

86435119461.

$$\frac{1}{2} \frac{ML^2}{\pi^2}$$

86435119462.

$$\frac{1}{4} \frac{ML^2}{\pi^2}$$

86435119463.

$$\frac{2}{5} \frac{ML^2}{\pi^2}$$

86435119464.

**Question Number : 7 Question Id : 8643516487 Question Type : MCQ Option Shuffling : Yes Is Question Mandatory : No**

**Correct Marks : 4 Wrong Marks : 1**

The speed of electrons in a scanning electron microscope is  $1 \times 10^7 \text{ ms}^{-1}$ . If the protons having the same speed are used instead of electrons, then the resolving power of scanning proton microscope will be changed by a factor of :

**Options :**

86435119465. 1837

$$86435119466. \frac{1}{1837}$$

$$86435119467. \frac{1}{\sqrt{1837}}$$

$$86435119468. \sqrt{1837}$$

**Question Number : 7 Question Id : 8643516487 Question Type : MCQ Option Shuffling : Yes Is Question Mandatory : No Correct Marks : 4 Wrong Marks : 1**

ଗୋଟିଏ ସ୍ଵାନିକ୍ ଇଲେକ୍ଟ୍ରନ୍ ଅଣୁବୀକ୍ଷଣ ଯନ୍ତ୍ରରେ ଇଲେକ୍ଟ୍ରନ୍ର ବେଗ  $1 \times 10^7 \text{ ms}^{-1}$  ଅଟେ । ଯଦି ଇଲେକ୍ଟ୍ରନ୍ ବଦଳରେ ସମାନ ବେଗ ଥିବା ପ୍ରୋଟନ୍‌କୁ ବ୍ୟବହାର କରାଯାଏ, ତେବେ ସ୍ଵାନିକ୍ ଇଲେକ୍ଟ୍ରନ୍ ଅଣୁବୀକ୍ଷଣ ଯନ୍ତ୍ରର ବିଭେଦନ କ୍ଷମତା ପରିବର୍ତ୍ତନ କେତେଗୁଣ ହେବ ?

**Options :**

$$86435119465. 1837$$

$$86435119466. \frac{1}{1837}$$

$$86435119467. \frac{1}{\sqrt{1837}}$$

$$86435119468. \sqrt{1837}$$

**Question Number : 8 Question Id : 8643516488 Question Type : MCQ Option Shuffling : Yes Is Question Mandatory : No Correct Marks : 4 Wrong Marks : 1**

The velocity - displacement graph of a particle is shown in the figure.

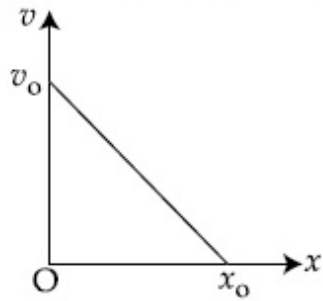

The acceleration - displacement graph of the same particle is represented by :

Options :

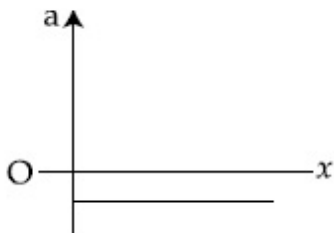

86435119469.

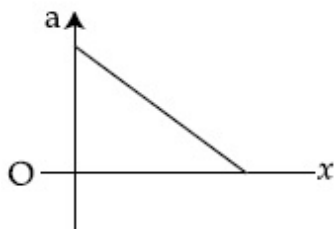

86435119470.

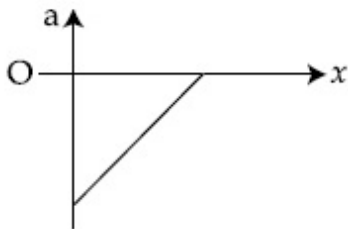

86435119471.

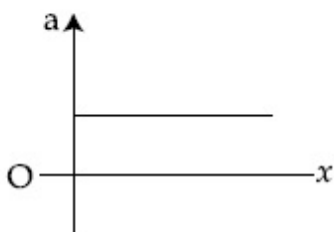

86435119472.

Question Number : 8 Question Id : 8643516488 Question Type : MCQ Option Shuffling : Yes Is  
 Question Mandatory : No  
 Correct Marks : 4 Wrong Marks : 1

ଚିତ୍ରଟିରେ ଗୋଟିଏ କଣିକାର ବେଗ-ଦିୱାପନର ଲେଖଚିତ୍ର ଦର୍ଶାଯାଇଛି ।

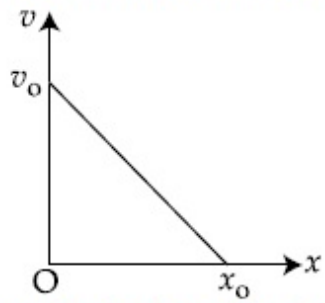

ସେହି କଣିକାଟିର ତ୍ୱରଣ-ଦିୱାପନର ଲେଖଚିତ୍ରଟି ଦର୍ଶାଯାଇପାରିବ :

Options :

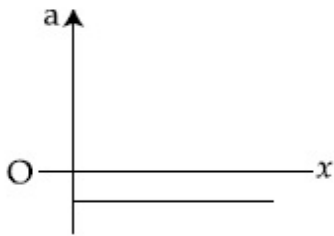

86435119469.

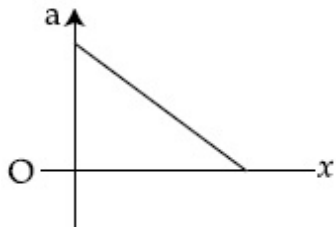

86435119470.

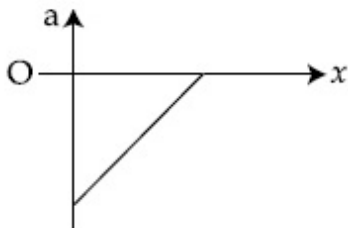

86435119471.

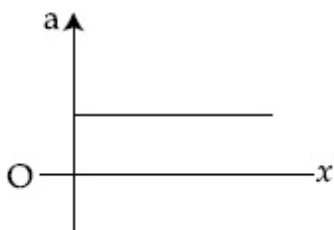

86435119472.

Question Number : 9 Question Id : 8643516489 Question Type : MCQ Option Shuffling : Yes Is Question Mandatory : No Correct Marks : 4 Wrong Marks : 1

For an adiabatic expansion of an ideal gas, the fractional change in its pressure is equal to (where  $\gamma$  is the ratio of specific heats) :

**Options :**

$$-\gamma \frac{dV}{V}$$

86435119473.

$$-\gamma \frac{V}{dV}$$

86435119474.

$$-\frac{1}{\gamma} \frac{dV}{V}$$

86435119475.

$$\frac{dV}{V}$$

86435119476.

**Question Number : 9 Question Id : 8643516489 Question Type : MCQ Option Shuffling : Yes Is Question Mandatory : No**

**Correct Marks : 4 Wrong Marks : 1**

ଗୋଟିଏ ଆଦର୍ଶ ଗ୍ୟାସର ରୁକ୍ଷତାପ ପ୍ରସାରଣ ପାଇଁ, ଏହାର ଚାପରେ ହେଉଥିବା ଭଗ୍ନାଂଶିକ ପରିବର୍ତ୍ତନ (ଯେଉଁଠାରେ ଚାପଧାରଣତାର ଅନୁପାତ  $\gamma$  ଅଟେ) ସମାନ ହେବ :

**Options :**

$$-\gamma \frac{dV}{V}$$

86435119473.

$$-\gamma \frac{V}{dV}$$

86435119474.

$$-\frac{1}{\gamma} \frac{dV}{V}$$

86435119475.

$$\frac{dV}{V}$$

86435119476.

**Question Number : 10 Question Id : 8643516490 Question Type : MCQ Option Shuffling : Yes Is Question Mandatory : No Correct Marks : 4 Wrong Marks : 1**

The angular momentum of a planet of mass  $M$  moving around the sun in an elliptical orbit is  $\vec{L}$ . The magnitude of the areal velocity of the planet is :

**Options :**

86435119477.  $\frac{L}{M}$

86435119478.  $\frac{L}{2M}$

86435119479.  $\frac{2L}{M}$

86435119480.  $\frac{4L}{M}$

**Question Number : 10 Question Id : 8643516490 Question Type : MCQ Option Shuffling : Yes Is Question Mandatory : No Correct Marks : 4 Wrong Marks : 1**

ସୂର୍ଯ୍ୟ ଚାରିପଟେ ଏକ ଅଣ୍ଡାକୃତି (ଇଲିପ୍ଟିକାଲ) କକ୍ଷପଥରେ  $M$  ବସ୍ତୁ ବିଶିଷ୍ଟ ଗୋଟିଏ ଗ୍ରହର କୌଣିକ ସଂବେଗ  $\vec{L}$  ଅଟେ । ଗ୍ରହଟିର କ୍ଷେତ୍ରାଞ୍ଚ ପରିବେଗର ପରିମାଣ ଅଟେ :

**Options :**

86435119477.  $\frac{L}{M}$

86435119478.  $\frac{L}{2M}$

86435119479.  $\frac{2L}{M}$

$$86435119480. \frac{4L}{M}$$

**Question Number : 11 Question Id : 8643516491 Question Type : MCQ Option Shuffling : Yes Is Question Mandatory : No**

**Correct Marks : 4 Wrong Marks : 1**

An ideal gas in a cylinder is separated by a piston in such a way that the entropy of one part is  $S_1$  and that of the other part is  $S_2$ . Given that  $S_1 > S_2$ . If the piston is removed then the total entropy of the system will be :

**Options :**

$$86435119481. S_1 \times S_2$$

$$86435119482. S_1 - S_2$$

$$86435119483. S_1 + S_2$$

$$86435119484. \frac{S_1}{S_2}$$

**Question Number : 11 Question Id : 8643516491 Question Type : MCQ Option Shuffling : Yes Is Question Mandatory : No**

**Correct Marks : 4 Wrong Marks : 1**

ଗୋଟିଏ ସିଲିଣ୍ଡରରେ ଏକ ଆଦର୍ଶ ଗ୍ୟାସକୁ ଏକ ପିଷ୍ଟନ୍ ଦ୍ୱାରା ଏପରି ଭାବରେ ଅଲଗା କରାଯାଇଛି ଯେମିତି ଗୋଟିଏ ଭାଗର ବିଶୁଦ୍ଧତା(ଏଣ୍ଟ୍ରୋପି)  $S_1$  ଅଟେ ଏବଂ ଅନ୍ୟ ଭାଗର ବିଶୁଦ୍ଧତା (ଏଣ୍ଟ୍ରୋପି)  $S_2$  ଅଟେ ।  $S_1 > S_2$  ବୋଲି ଦିଆଯାଇଛି । ଯଦି ପିଷ୍ଟନ୍‌ଟିକୁ କାଢ଼ିନିଆଯାଏ, ତେବେ ପ୍ରଣାଳୀଟିର ମୋଟ ବିଶୁଦ୍ଧତା(ଏଣ୍ଟ୍ରୋପି) ହେବ :

**Options :**

$$86435119481. S_1 \times S_2$$

$$86435119482. S_1 - S_2$$

$$86435119483. S_1 + S_2$$

$$86435119484. \frac{S_1}{S_2}$$

**Question Number : 12 Question Id : 8643516492 Question Type : MCQ Option Shuffling : Yes Is Question Mandatory : No Correct Marks : 4 Wrong Marks : 1**

The function of time representing a simple harmonic motion with a period of  $\frac{\pi}{\omega}$  is :

**Options :**

86435119485.  $\sin(\omega t) + \cos(\omega t)$

86435119486.  $\sin^2(\omega t)$

86435119487.  $3 \cos\left(\frac{\pi}{4} - 2\omega t\right)$

86435119488.  $\cos(\omega t) + \cos(2\omega t) + \cos(3\omega t)$

**Question Number : 12 Question Id : 8643516492 Question Type : MCQ Option Shuffling : Yes Is Question Mandatory : No Correct Marks : 4 Wrong Marks : 1**

ଆବର୍ତ୍ତକାଳ  $\frac{\pi}{\omega}$  ଥିବା ଏକ ସରଳ ହାରମୋନିକ ଗତିକୁ ବର୍ଣ୍ଣାୟିତ୍ବା ସମୟର ଫଳନ ଅଟେ :

**Options :**

86435119485.  $\sin(\omega t) + \cos(\omega t)$

86435119486.  $\sin^2(\omega t)$

86435119487.  $3 \cos\left(\frac{\pi}{4} - 2\omega t\right)$

86435119488.  $\cos(\omega t) + \cos(2\omega t) + \cos(3\omega t)$

**Question Number : 13 Question Id : 8643516493 Question Type : MCQ Option Shuffling : Yes Is Question Mandatory : No Correct Marks : 4 Wrong Marks : 1**



In a series LCR circuit, the inductive reactance ( $X_L$ ) is  $10 \Omega$  and the capacitive reactance ( $X_C$ ) is  $4 \Omega$ . The resistance (R) in the circuit is  $6 \Omega$ .

The power factor of the circuit is :

Options :

86435119489.  $\frac{1}{\sqrt{2}}$

86435119490.  $\frac{\sqrt{3}}{2}$

86435119491.  $\frac{1}{2}$

86435119492.  $\frac{1}{2\sqrt{2}}$

Question Number : 13 Question Id : 8643516493 Question Type : MCQ Option Shuffling : Yes Is Question Mandatory : No

Correct Marks : 4 Wrong Marks : 1

ଗୋଟିଏ ଶ୍ରେଣୀରେ ସଂଯୁକ୍ତ LCR ବିଦ୍ୟୁତ୍ ପରିପଥରେ, ପ୍ରଶୋଦନ ପ୍ରତିଘାତ ( $X_L$ ) ହେଉଛି  $10 \Omega$  ଏବଂ ଧାରିତା ପ୍ରତିଘାତ ( $X_C$ ) ହେଉଛି  $4 \Omega$  । ପରିପଥରେ ବିଦ୍ୟୁତ୍ ପ୍ରତିରୋଧ (R)  $6 \Omega$  ଅଟେ । ପରିପଥର ଶକ୍ତିକାରକ (ପାଞ୍ଜାର ଫାକ୍ଟର) ଅଟେ :

Options :

86435119489.  $\frac{1}{\sqrt{2}}$

86435119490.  $\frac{\sqrt{3}}{2}$

86435119491.  $\frac{1}{2}$

86435119492.  $\frac{1}{2\sqrt{2}}$

Question Number : 14 Question Id : 8643516494 Question Type : MCQ Option Shuffling : Yes Is Question Mandatory : No

**Correct Marks : 4 Wrong Marks : 1**

Which of the following statements are correct ?

- (A) Electric monopoles do not exist whereas magnetic monopoles exist.
- (B) Magnetic field lines due to a solenoid at its ends and outside cannot be completely straight and confined.
- (C) Magnetic field lines are completely confined within a toroid.
- (D) Magnetic field lines inside a bar magnet are not parallel.
- (E)  $\chi = -1$  is the condition for a perfect diamagnetic material, where  $\chi$  is its magnetic susceptibility.

Choose the correct answer from the options given below :

**Options :**

86435119493. (B) and (D) only

86435119494. (B) and (C) only

86435119495. (A) and (B) only

86435119496. (C) and (E) only

**Question Number : 14 Question Id : 8643516494 Question Type : MCQ Option Shuffling : Yes Is Question Mandatory : No**

**Correct Marks : 4 Wrong Marks : 1**

ନିମ୍ନଲିଖିତ ଉଚ୍ଚିଗୁଡ଼ିକ ମଧ୍ୟରୁ କେଉଁଗୁଡ଼ିକ ସଠିକ୍ ଅଟନ୍ତି ?

- (A) ତୁମ୍ବକୀୟ ଏକମେରୁ ଯେଉଁଠାରେ ରହେ ସେଠାରେ ବୈଦ୍ୟୁତିକ ଏକମେରୁ ରହନ୍ତି ନାହିଁ ।
- (B) ଗୋଟିଏ ସଲିନଏଡ୍ ପାଇଁ ତୁମ୍ବକୀୟ କ୍ଷେତ୍ର ରେଖାଗୁଡ଼ିକ ଏହାର ପ୍ରାନ୍ତରେ ଏବଂ ବାହାରେ ସଂପୂର୍ଣ୍ଣ ଭାବେ ସିଧା ଏବଂ ସୀମାବଦ୍ଧ କରିହେବ ନାହିଁ ।
- (C) କୁଣ୍ଡଳାକୃତି ତାର (ଟରଏଡ୍) ମଧ୍ୟରେ ତୁମ୍ବକୀୟ କ୍ଷେତ୍ର ରେଖାଗୁଡ଼ିକ ସଂପୂର୍ଣ୍ଣ ଭାବରେ ସୀମାବଦ୍ଧ ହୋଇଥାଏ ।
- (D) ଗୋଟିଏ ଦଣ୍ଡ ତୁମ୍ବକ ମଧ୍ୟରେ ତୁମ୍ବକୀୟ କ୍ଷେତ୍ର ରେଖାଗୁଡ଼ିକ ସମାନ୍ତର ନୁହନ୍ତି ।
- (E) ଗୋଟିଏ ଶୁଦ୍ଧ ପ୍ରତିତୁମ୍ବକୀୟ ପଦାର୍ଥ ପାଇଁ  $\chi = -1$ , ଯେଉଁଠାରେ  $\chi$  ଏହାର ତୁମ୍ବକୀୟ ପ୍ରବଣତା ଅଟେ ।

ନିମ୍ନରେ ଦିଆଯାଇଥିବା ବିକଳଗୁଡ଼ିକରୁ ଠିକ୍ ଉତ୍ତର ଚୟନ କର :

**Options :**

86435119493. କେବଳ (B) ଏବଂ (D)

86435119494. କେବଳ (B) ଏବଂ (C)

86435119495. କେବଳ (A) ଏବଂ (B)

86435119496. କେବଳ (C) ଏବଂ (E)

**Question Number : 15 Question Id : 8643516495 Question Type : MCQ Option Shuffling : Yes Is**

**Question Mandatory : No**

**Correct Marks : 4 Wrong Marks : 1**

The correct relation between  $\alpha$  (ratio of collector current to emitter current) and  $\beta$  (ratio of collector current to base current) of a transistor is :

**Options :**

$$\beta = \frac{\alpha}{1 + \alpha}$$

86435119497.

$$\alpha = \frac{\beta}{1 - \alpha}$$

86435119498.

$$\beta = \frac{1}{1 - \alpha}$$

86435119499.

$$\alpha = \frac{\beta}{1 + \beta}$$

86435119500.

**Question Number : 15 Question Id : 8643516495 Question Type : MCQ Option Shuffling : Yes Is**

**Question Mandatory : No**

**Correct Marks : 4 Wrong Marks : 1**

ଏକ ଟ୍ରାଞ୍ଜିଷ୍ଟରର  $\alpha$  (ସଂଗ୍ରାହୀ ବିଦ୍ୟୁତ୍ ସ୍ରୋତ ଓ ଏମିଟର ବିଦ୍ୟୁତ୍ ସ୍ରୋତର ଅନୁପାତ) ଏବଂ  $\beta$  (ସଂଗ୍ରାହୀ ବିଦ୍ୟୁତ୍ ସ୍ରୋତ ଓ ବେସ୍ ବିଦ୍ୟୁତ୍ ସ୍ରୋତର ଅନୁପାତ) ମଧ୍ୟରେ ଥିବା ଠିକ୍ ସମ୍ପର୍କଟି ହେଉଛି :

**Options :**

$$\beta = \frac{\alpha}{1 + \alpha}$$

86435119497.

$$\alpha = \frac{\beta}{1 - \alpha}$$

86435119498.

$$\beta = \frac{1}{1 - \alpha}$$

86435119499.

$$\alpha = \frac{\beta}{1 + \beta}$$

86435119500.

**Question Number : 16 Question Id : 8643516496 Question Type : MCQ Option Shuffling : Yes Is Question Mandatory : No**

**Correct Marks : 4 Wrong Marks : 1**

A proton and an  $\alpha$ -particle, having kinetic energies  $K_p$  and  $K_\alpha$  respectively, enter into a magnetic field at right angles.

The ratio of the radii of trajectory of proton to that of  $\alpha$ -particle is 2 : 1. The ratio of  $K_p : K_\alpha$  is :

**Options :**

86435119501. 1 : 4

86435119502. 4 : 1

86435119503. 8 : 1

86435119504. 1 : 8

**Question Number : 16 Question Id : 8643516496 Question Type : MCQ Option Shuffling : Yes Is Question Mandatory : No**

**Correct Marks : 4 Wrong Marks : 1**

ଗତିଜ ଶକ୍ତି ଯଥାକ୍ରମେ  $K_p$  ଏବଂ  $K_\alpha$  ରହିଥିବା ଗୋଟିଏ ପ୍ରୋଟନ୍ ଏବଂ  $\alpha$ -କଣିକା ଲମ୍ବ ଭାବରେ (ସମକୋଣରେ) ଏକ ବୃନ୍ଦକାରୀ କ୍ଷେତ୍ରକୁ ପ୍ରବେଶ କରୁଛନ୍ତି ।

ପ୍ରୋଟନ୍ ଏବଂ  $\alpha$ -କଣିକାର ପ୍ରକ୍ଷେପ ପଥର ବ୍ୟାସାର୍ଦ୍ଧ ଗୁଡ଼ିକର ଅନୁପାତ 2 : 1 ଅଟେ ।  $K_p : K_\alpha$  ର ଅନୁପାତ ଅଟେ :

**Options :**

86435119501. 1 : 4

86435119502. 4 : 1

86435119503. 8 : 1

86435119504. 1 : 8

**Question Number : 17 Question Id : 8643516497 Question Type : MCQ Option Shuffling : Yes Is Question Mandatory : No**

**Correct Marks : 4 Wrong Marks : 1**

Three rays of light, namely red (R), green (G) and blue (B) are incident on the face PQ of a right angled prism PQR as shown in the figure.

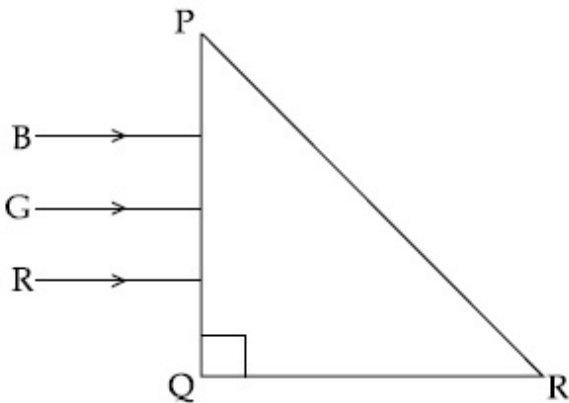

The refractive indices of the material of the prism for red, green and blue wavelength are 1.27, 1.42 and 1.49 respectively. The colour of the ray(s) emerging out of the face PR is :

**Options :**

86435119505. blue and green

86435119506. blue

86435119507. green

86435119508. red

**Question Number : 17 Question Id : 8643516497 Question Type : MCQ Option Shuffling : Yes Is Question Mandatory : No**

**Correct Marks : 4 Wrong Marks : 1**



ଚିତ୍ରରେ ଦର୍ଶାଯାଇଥିବା ଅନୁସାରେ, ଏକ ସମକୋଣୀ ପ୍ରିଜମ୍ PQR ର PQ ପାର୍ଶ୍ୱରେ ତିନୋଟି ଆଲୋକ ରଶ୍ମି ଯଥା ଲାଲ (R), ସବୁଜ (G) ଏବଂ ନୀଳ (B) ଆପତ୍ତିତ ହେଉଛନ୍ତି ।

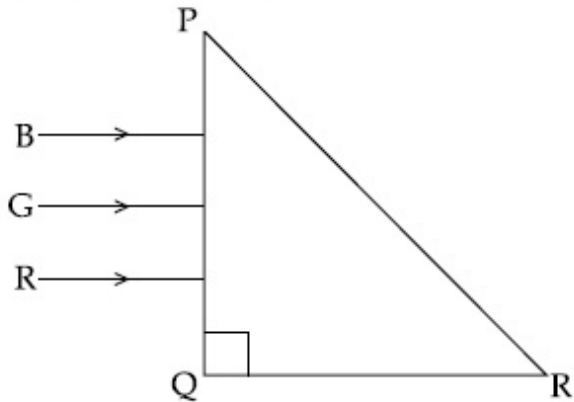

ଲାଲ, ସବୁଜ ଏବଂ ନୀଳ ତରଙ୍ଗ ଦୈର୍ଘ୍ୟ ପାଇଁ ପ୍ରିଜମ୍ ପଦାର୍ଥର ପ୍ରତିସରଣାଙ୍କ ଯଥାକ୍ରମେ 1.27, 1.42 ଏବଂ 1.49 ଅଟେ । PR ପାର୍ଶ୍ୱଦେଇ ବାହାରି ଯାଇଥିବା ରଶ୍ମି (ରଶ୍ମିଗୁଡ଼ିକ)ର ରଙ୍ଗ ଅଟେ :

**Options :**

86435119505. ନୀଳ ଏବଂ ସବୁଜ

86435119506. ନୀଳ

86435119507. ସବୁଜ

86435119508. ଲାଲ

**Question Number : 18 Question Id : 8643516498 Question Type : MCQ Option Shuffling : Yes Is**

**Question Mandatory : No**

**Correct Marks : 4 Wrong Marks : 1**

The time taken for the magnetic energy to reach 25% of its maximum value, when a solenoid of resistance R, inductance L is connected to a battery, is :

**Options :**

86435119509.  $\frac{L}{R} \ln 2$

86435119510.  $\frac{L}{R} \ln 5$

86435119511.  $\frac{L}{R} \ln 10$

86435119512. infinite

**Question Number : 18 Question Id : 8643516498 Question Type : MCQ Option Shuffling : Yes Is Question Mandatory : No**

**Correct Marks : 4 Wrong Marks : 1**

ଯେତେବେଳେ ବିଦ୍ୟୁତ୍ ପ୍ରତିରୋଧ  $R$  ଏବଂ ପ୍ରଶୋବକତା  $L$  ବିଶିଷ୍ଟ ଗୋଟିଏ ସଲିନିଓଇଡ୍‌କୁ ବ୍ୟାଚେରୀ ସହ ସଂଯୋଗ କରାଯାଏ, ସେତେବେଳେ ତୁଳ୍ୟକାରୀ ଶକ୍ତି ଏହାର ସର୍ବାଧିକ ମୂଲ୍ୟର 25% ରେ ପହଞ୍ଚିବା ପାଇଁ ନେଉଥିବା ସମୟ ହେବ :

**Options :**

86435119509.  $\frac{L}{R} \ln 2$

86435119510.  $\frac{L}{R} \ln 5$

86435119511.  $\frac{L}{R} \ln 10$

86435119512. ଅସୀମ

**Question Number : 19 Question Id : 8643516499 Question Type : MCQ Option Shuffling : Yes Is Question Mandatory : No**

**Correct Marks : 4 Wrong Marks : 1**

A plane electromagnetic wave propagating along  $y$ -direction can have the following pair of electric field ( $\vec{E}$ ) and magnetic field ( $\vec{B}$ ) components.

**Options :**

86435119513.  $E_y, B_y$  or  $E_z, B_z$

86435119514.  $E_x, B_y$  or  $E_y, B_x$

86435119515.  $E_x, B_z$  or  $E_z, B_x$

86435119516.  $E_y, B_x$  or  $E_x, B_y$

**Question Number : 19 Question Id : 8643516499 Question Type : MCQ Option Shuffling : Yes Is Question Mandatory : No**

**Correct Marks : 4 Wrong Marks : 1**

$y$ -ଦିଗରେ ଗତି କରୁଥିବା ଗୋଟିଏ ବିଦ୍ୟୁତ୍-ଚୁମ୍ବକୀୟ ତରଙ୍ଗର ନିମ୍ନରେ ଦତ୍ତ କେଉଁ ବୈଦ୍ୟୁତିକ କ୍ଷେତ୍ର  $(\vec{E})$  ଏବଂ ଚୁମ୍ବକୀୟ କ୍ଷେତ୍ର  $(\vec{B})$  ଉପାଦାନଗୁଡ଼ିକର ଯୋଡ଼ା ରହିବ ?

**Options :**

86435119513.  $E_y, B_y$  କିମ୍ବା  $E_z, B_z$

86435119514.  $E_x, B_y$  କିମ୍ବା  $E_y, B_x$

86435119515.  $E_x, B_z$  କିମ୍ବା  $E_z, B_x$

86435119516.  $E_y, B_x$  କିମ୍ବା  $E_x, B_y$

**Question Number : 20 Question Id : 8643516500 Question Type : MCQ Option Shuffling : Yes Is Question Mandatory : No**

**Correct Marks : 4 Wrong Marks : 1**

The decay of a proton to neutron is :

**Options :**

86435119517. not possible as proton mass is less than the neutron mass

86435119518. possible only inside the nucleus

86435119519. always possible as it is associated only with  $\beta^+$  decay

86435119520. not possible but neutron to proton conversion is possible

**Question Number : 20 Question Id : 8643516500 Question Type : MCQ Option Shuffling : Yes Is Question Mandatory : No**

**Correct Marks : 4 Wrong Marks : 1**

ନ୍ୟୁଟ୍ରନ୍‌କୁ ପ୍ରୋଟନ୍‌ର କ୍ଷୟ :



**Options :**

86435119517. ସମ୍ଭବ ନୁହେଁ ଯେହେତୁ ପ୍ରୋଟନ୍‌ର ବସ୍ତୁତ୍ୱ ନ୍ୟୁଟ୍ରନ୍‌ର ବସ୍ତୁତ୍ୱ ଠାରୁ କମ୍ ।

86435119518. କେବଳ ନ୍ୟୁକ୍ଲିୟସ୍ ମଧ୍ୟରେ ସମ୍ଭବ ।

86435119519. ସର୍ବଦା ସମ୍ଭବ ଯେହେତୁ ଏହା  $\beta^+$  କ୍ଷୟ ସହ ସଂପୃକ୍ତ ।

86435119520. ସମ୍ଭବ ନୁହେଁ କିନ୍ତୁ ନ୍ୟୁଟ୍ରନ୍‌ରୁ ପ୍ରୋଟନ୍‌ର ପରିବର୍ତ୍ତନ ସମ୍ଭବ ।

**Physics Section B**

<b>Section Id :</b>	864351434
<b>Section Number :</b>	2
<b>Section type :</b>	Online
<b>Mandatory or Optional :</b>	Mandatory
<b>Number of Questions :</b>	10
<b>Number of Questions to be attempted :</b>	5
<b>Section Marks :</b>	20
<b>Mark As Answered Required? :</b>	Yes
<b>Sub-Section Number :</b>	1
<b>Sub-Section Id :</b>	864351434
<b>Question Shuffling Allowed :</b>	Yes

**Question Number : 21 Question Id : 8643516501 Question Type : SA**

**Correct Marks : 4 Wrong Marks : 0**

The projectile motion of a particle of mass 5 g is shown in the figure.



The initial velocity of the particle is  $5\sqrt{2} \text{ ms}^{-1}$  and the air resistance is assumed to be negligible.

The magnitude of the change in momentum between the points A and B is  $x \times 10^{-2} \text{ kgms}^{-1}$ .

The value of  $x$ , to the nearest integer, is \_\_\_\_\_.

**Response Type :** Numeric

**Evaluation Required For SA :** Yes

**Show Word Count :** Yes

**Answers Type :** Equal

**Text Areas :** PlainText

**Possible Answers :**

100

**Question Number : 21 Question Id : 8643516501 Question Type : SA****Correct Marks : 4 Wrong Marks : 0**

5 g ବସ୍ତୁର ବିଶିଷ୍ଟ ଏକ କଣିକାର ପ୍ରକ୍ଷେପଣ ଗତିକୁ ଚିତ୍ରରେ ଦର୍ଶାଯାଇଅଛି ।

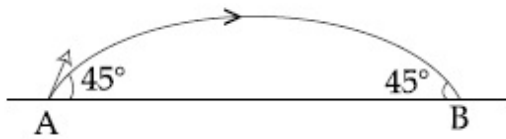

କଣିକାଟିର ପ୍ରାରମ୍ଭିକ ବେଗ  $5\sqrt{2} \text{ ms}^{-1}$  ଅଟେ ଏବଂ ବାୟୁମଣ୍ଡଳୀୟ ପ୍ରତିରୋଧକୁ ନଗଣ୍ୟ ବୋଲି ବିବେଚନା କରାଯାଏ । A ଓ B ବିନ୍ଦୁ ଦୁଇଟି ମଧ୍ୟରେ ସଂବେଗର ପରିବର୍ତ୍ତନର ପରିମାଣ  $x \times 10^{-2} \text{ kgms}^{-1}$  ଅଟେ ।  $x$  ର ମୂଲ୍ୟ ହେବ \_\_\_\_\_ ।

**Response Type : Numeric****Evaluation Required For SA : Yes****Show Word Count : Yes****Answers Type : Equal****Text Areas : PlainText****Possible Answers :**

100

**Question Number : 22 Question Id : 8643516502 Question Type : SA****Correct Marks : 4 Wrong Marks : 0**

An infinite number of point charges, each carrying  $1 \mu\text{C}$  charge, are placed along the  $y$ -axis at  $y = 1 \text{ m}, 2 \text{ m}, 4 \text{ m}, 8 \text{ m} \dots$

The total force on a  $1 \text{ C}$  point charge, placed at the origin, is  $x \times 10^3 \text{ N}$ .

The value of  $x$ , to the nearest integer, is \_\_\_\_\_.

$$\left[ \text{Take } \frac{1}{4\pi\epsilon_0} = 9 \times 10^9 \text{ Nm}^2/\text{C}^2 \right]$$

**Response Type : Numeric****Evaluation Required For SA : Yes****Show Word Count : Yes****Answers Type : Equal****Text Areas : PlainText****Possible Answers :**

100

**Question Number : 22 Question Id : 8643516502 Question Type : SA****Correct Marks : 4 Wrong Marks : 0**

$y$ -ଅକ୍ଷ ଉପରେ  $y = 1 \text{ m}, 2 \text{ m}, 4 \text{ m}, 8 \text{ m} \dots\dots\dots$  ଠାରେ ପ୍ରତ୍ୟେକ  $1 \mu\text{C}$  ଚାର୍ଜ ବହନ କରୁଥିବା ଅସଂଖ୍ୟ ଚାର୍ଜ ବିନ୍ଦୁଗୁଡ଼ିକୁ ରଖାଯାଇଛି ।

ମୂଳବିନ୍ଦୁ (ଅରିଜିନ) ରେ ଥିବା  $1 \text{ C}$  ର ଚାର୍ଜ ବିନ୍ଦୁ ଉପରେ ପଡୁଥିବା ସମୁଦାୟ ବଳର ପରିମାଣ  $x \times 10^3 \text{ N}$  ଅଟେ ।  $x$  ର ମୂଲ୍ୟ ଅଟେ \_\_\_\_\_ ।

$$\left[ \frac{1}{4\pi\epsilon_0} = 9 \times 10^9 \text{ Nm}^2/\text{C}^2 \text{ ନିଅ} \right]$$

**Response Type :** Numeric

**Evaluation Required For SA :** Yes

**Show Word Count :** Yes

**Answers Type :** Equal

**Text Areas :** PlainText

**Possible Answers :**

100

**Question Number :** 23 **Question Id :** 8643516503 **Question Type :** SA

**Correct Marks :** 4 **Wrong Marks :** 0

Two wires of same length and thickness having specific resistances  $6 \Omega \text{ cm}$  and  $3 \Omega \text{ cm}$  respectively are connected in parallel. The effective resistivity is  $\rho \Omega \text{ cm}$ . The value of  $\rho$ , to the nearest integer, is \_\_\_\_\_.

**Response Type :** Numeric

**Evaluation Required For SA :** Yes

**Show Word Count :** Yes

**Answers Type :** Equal

**Text Areas :** PlainText

**Possible Answers :**

100

**Question Number :** 23 **Question Id :** 8643516503 **Question Type :** SA

**Correct Marks :** 4 **Wrong Marks :** 0

ଦ୍ୱିଶ୍ଳେଷ ପ୍ରତିରୋଧ ଯଥାକ୍ରମେ  $6 \Omega \text{ cm}$  ଏବଂ  $3 \Omega \text{ cm}$  ଥିବା ଦୁଇଟି ସମାନ ଦୈର୍ଘ୍ୟ ଏବଂ ମୋଟେଇର ତାରକୁ ସମାନ୍ତର ଭାବେ ସଂଯୋଗ କରାଯାଇଛି । କାର୍ଯ୍ୟକାରୀ ପ୍ରତିରୋଧତା  $\rho \Omega \text{ cm}$  ଅଟେ ।  $\rho$  ର ମୂଲ୍ୟ ଅଟେ \_\_\_\_\_ ।

**Response Type :** Numeric

**Evaluation Required For SA :** Yes

**Show Word Count :** Yes

**Answers Type :** Equal

**Text Areas :** PlainText

**Possible Answers :**

100

**Question Number : 24 Question Id : 8643516504 Question Type : SA**

**Correct Marks : 4 Wrong Marks : 0**

A ball of mass 4 kg, moving with a velocity of  $10 \text{ ms}^{-1}$ , collides with a spring of length 8 m and force constant  $100 \text{ Nm}^{-1}$ . The length of the compressed spring is  $x$  m. The value of  $x$ , to the nearest integer, is \_\_\_\_\_.

**Response Type : Numeric**

**Evaluation Required For SA : Yes**

**Show Word Count : Yes**

**Answers Type : Equal**

**Text Areas : PlainText**

**Possible Answers :**

100

**Question Number : 24 Question Id : 8643516504 Question Type : SA**

**Correct Marks : 4 Wrong Marks : 0**

$10 \text{ ms}^{-1}$  ପରିବେଗରେ ଗତି କରୁଥିବା 4 kg ବସ୍ତୁର ବିଶିଷ୍ଟ ଗୋଟିଏ ବଲ୍ 8 m ଦୈର୍ଘ୍ୟ ଏବଂ  $100 \text{ Nm}^{-1}$  ବଳ ସ୍ଥିରୀକରଣ ଥିବା ଗୋଟିଏ ସ୍ପ୍ରିଙ୍ଗ୍ ସହ ଧକ୍କା ହେଲା । ସଂକୋଚିତ ହୋଇଥିବା ସ୍ପ୍ରିଙ୍ଗର ଦୈର୍ଘ୍ୟ  $x$  m ଅଟେ ।  $x$  ର ମୂଲ୍ୟ ଅଟେ \_\_\_\_\_ ।

**Response Type : Numeric**

**Evaluation Required For SA : Yes**

**Show Word Count : Yes**

**Answers Type : Equal**

**Text Areas : PlainText**

**Possible Answers :**

100

**Question Number : 25 Question Id : 8643516505 Question Type : SA**

**Correct Marks : 4 Wrong Marks : 0**

The typical output characteristics curve for a transistor working in the common-emitter configuration is shown in the figure.

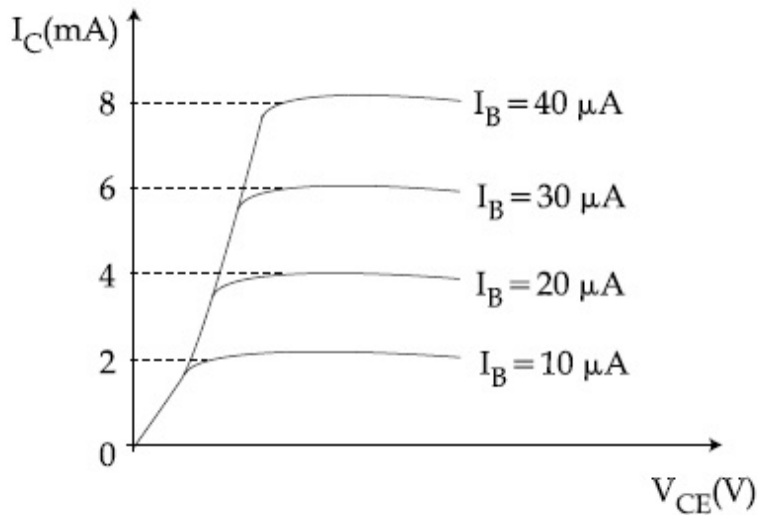

The estimated current gain from the figure is \_\_\_\_\_.

**Response Type :** Numeric

**Evaluation Required For SA :** Yes

**Show Word Count :** Yes

**Answers Type :** Equal

**Text Areas :** PlainText

**Possible Answers :**

100

**Question Number :** 25 **Question Id :** 8643516505 **Question Type :** SA

**Correct Marks :** 4 **Wrong Marks :** 0

ଚିତ୍ରଟିରେ ସାଧାରଣ ଉତ୍ପନ୍ନକ ବିନ୍ୟାସରେ କାର୍ଯ୍ୟ କରୁଥିବା ଏକ ଟ୍ରାଞ୍ଜିଷ୍ଟରର ବହିର୍ବେଗ ଅଭିଲକ୍ଷଣୀକରଣର ବକ୍ରରେଖା ଦର୍ଶାଯାଇଛି ।

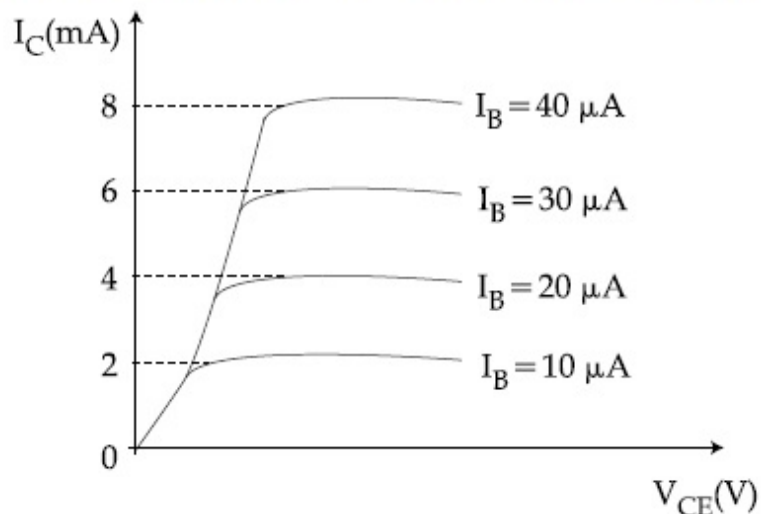

ଚିତ୍ରଟିରୁ ଆକଳନ ଲକ୍ଷ ବିନ୍ୟାସର ସ୍ତୋତ ଅଟେ \_\_\_\_\_ ।

**Response Type :** Numeric

**Evaluation Required For SA :** Yes

Show Word Count : Yes

Answers Type : Equal

Text Areas : PlainText

Possible Answers :

100

Question Number : 26 Question Id : 8643516506 Question Type : SA

Correct Marks : 4 Wrong Marks : 0

Consider a 72 cm long wire AB as shown in the figure. The galvanometer jockey is placed at P on AB at a distance  $x$  cm from A. The galvanometer shows zero deflection.

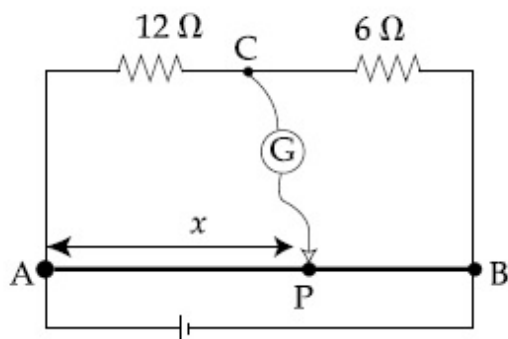

The value of  $x$ , to the nearest integer, is \_\_\_\_\_.

Response Type : Numeric

Evaluation Required For SA : Yes

Show Word Count : Yes

Answers Type : Equal

Text Areas : PlainText

Possible Answers :

100

Question Number : 26 Question Id : 8643516506 Question Type : SA

Correct Marks : 4 Wrong Marks : 0



ଚିତ୍ରରେ ଦର୍ଶାଯାଇଥିବା ଅନୁସାରେ 72 cm ଦୈର୍ଘ୍ୟର ତାରକୁ ବିଚାର କର । ଗାଲଭାନୋମିଟର ଜକିଟି AB ଉପରେ A ଠାରୁ  $x$  cm ଦୂରତାରେ ଥିବା P ବିନ୍ଦୁରେ ରହିଛି । ଗାଲଭାନୋ ମିଟରଟି ଶୂନ୍ୟ(ଜିରୋ) ବିକ୍ଷେପ ଦର୍ଶାଉଛି ।

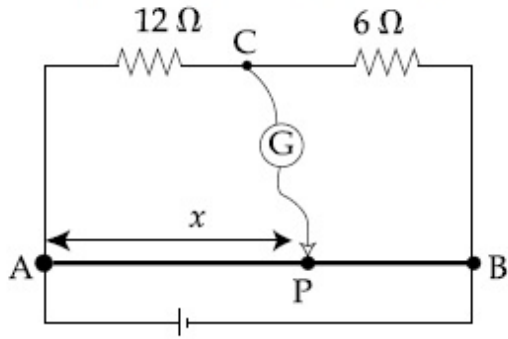

$x$  ର ମୂଲ୍ୟ ଅଟେ \_\_\_\_\_ ।

**Response Type :** Numeric

**Evaluation Required For SA :** Yes

**Show Word Count :** Yes

**Answers Type :** Equal

**Text Areas :** PlainText

**Possible Answers :**

100

**Question Number :** 27 **Question Id :** 8643516507 **Question Type :** SA

**Correct Marks :** 4 **Wrong Marks :** 0

A galaxy is moving away from the earth at a speed of  $286 \text{ kms}^{-1}$ . The shift in the wavelength of a redline at  $630 \text{ nm}$  is  $x \times 10^{-10} \text{ m}$ .

The value of  $x$ , to the nearest integer, is \_\_\_\_\_.

[Take the value of speed of light  $c$ , as  $3 \times 10^8 \text{ ms}^{-1}$ ]

**Response Type :** Numeric

**Evaluation Required For SA :** Yes

**Show Word Count :** Yes

**Answers Type :** Equal

**Text Areas :** PlainText

**Possible Answers :**

100

**Question Number :** 27 **Question Id :** 8643516507 **Question Type :** SA

**Correct Marks :** 4 **Wrong Marks :** 0

ଏକ ଛାୟାପଥ (ଗାଲଭି)  $286 \text{ kms}^{-1}$  ବେଗରେ ପୃଥିବୀ ଠାରୁ ଦୂରେଇ ଯାଉଛି । ଏକ  $630 \text{ nm}$  ର ଲାଲ ତରଙ୍ଗ ଦୈର୍ଘ୍ୟରେ ହେଉଥିବା ପରିବର୍ତ୍ତନ ଅଟେ  $x \times 10^{-10} \text{ m}$  । ନିକଟତମ ପୂର୍ଣ୍ଣସଂଖ୍ୟାରେ  $x$  ର ମୂଲ୍ୟ ଅଟେ \_\_\_\_\_ ।

(ଆଲୋକର ବେଗ  $c$  କୁ  $3 \times 10^8 \text{ ms}^{-1}$  ବୋଲି ନିଅ)

**Response Type :** Numeric

**Evaluation Required For SA :** Yes

Show Word Count : Yes

Answers Type : Equal

Text Areas : PlainText

Possible Answers :

100

Question Number : 28 Question Id : 8643516508 Question Type : SA

Correct Marks : 4 Wrong Marks : 0

Consider a water tank as shown in the figure. It's cross-sectional area is  $0.4 \text{ m}^2$ . The tank has an opening B near the bottom whose cross-section area is  $1 \text{ cm}^2$ . A load of 24 kg is applied on the water at the top when the height of the water level is 40 cm above the bottom, the velocity of water coming out the opening B is  $v \text{ ms}^{-1}$ .

The value of  $v$ , to the nearest integer, is \_\_\_\_\_.

[Take value of  $g$  to be  $10 \text{ ms}^{-2}$ ]

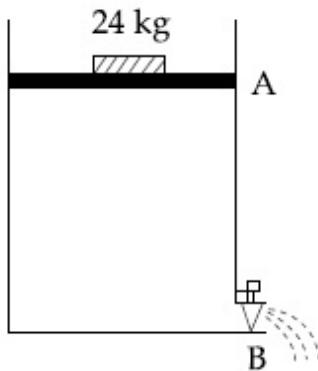

Response Type : Numeric

Evaluation Required For SA : Yes

Show Word Count : Yes

Answers Type : Equal

Text Areas : PlainText

Possible Answers :

100

Question Number : 28 Question Id : 8643516508 Question Type : SA

Correct Marks : 4 Wrong Marks : 0



ଚିତ୍ରରେ ଦର୍ଶାଯାଇଥିବା ଅନୁସାରେ ଗୋଟିଏ ପାଣି ଟାଙ୍କିକୁ ବିଚାର କର । ଏହାର ପ୍ରସ୍ଥଭେଦର କ୍ଷେତ୍ରଫଳ  $0.4 \text{ m}^2$  ଅଟେ । ଟାଙ୍କିର ନିମ୍ନ ଭାଗରେ ଗୋଟିଏ ଛିଦ୍ର B ରହିଛି ଯାହାର ପ୍ରସ୍ଥଭେଦର କ୍ଷେତ୍ରଫଳ  $1 \text{ cm}^2$  ଅଟେ । ଜଳ ଉପରେ  $24 \text{ kg}$  ର ଓଜନ ଦିଆଗଲା । ଯେତେବେଳେ ପାଣିଟାଙ୍କିର ଜଳସ୍ତରର ଉଚ୍ଚତା  $40 \text{ cm}$  ଥାଏ, ସେତେବେଳେ B କଣା ଦେଇ ପ୍ରବାହିତ ଜଳ ସ୍ରୋତର ବେଗ  $v \text{ ms}^{-1}$  ଅଟେ । ନିକଟତମ ପୂର୍ଣ୍ଣସଂଖ୍ୟାରେ  $v$  ର ମୂଲ୍ୟ ଅଟେ \_\_\_\_\_ ।  
( $g$  ର ମୂଲ୍ୟ  $10 \text{ ms}^{-2}$  ବୋଲି ନିଅ)

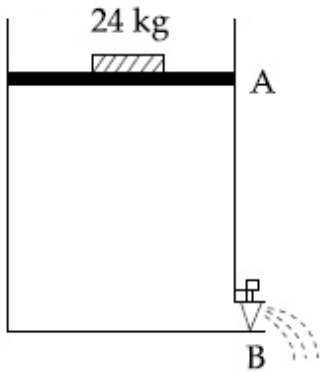

**Response Type :** Numeric

**Evaluation Required For SA :** Yes

**Show Word Count :** Yes

**Answers Type :** Equal

**Text Areas :** PlainText

**Possible Answers :**

100

**Question Number :** 29 **Question Id :** 8643516509 **Question Type :** SA

**Correct Marks :** 4 **Wrong Marks :** 0

A TV transmission tower antenna is at a height of 20 m. Suppose that the receiving antenna is at.

- (i) ground level
- (ii) a height of 5 m.

The increase in antenna range in case (ii) relative to case (i) is  $n\%$ .

The value of  $n$ , to the nearest integer, is \_\_\_\_\_.

**Response Type :** Numeric

**Evaluation Required For SA :** Yes

**Show Word Count :** Yes

**Answers Type :** Equal

**Text Areas :** PlainText

**Possible Answers :**

100

**Question Number :** 29 **Question Id :** 8643516509 **Question Type :** SA

**Correct Marks :** 4 **Wrong Marks :** 0

ଗୋଟିଏ ଦୂରଦର୍ଶନ ପ୍ରସାରଣ ଗମ୍ଭୀର ଉଚ୍ଚତା 20 m ରହିଛି । ମନେକର ତରଙ୍ଗ ଗ୍ରହଣ କରୁଥିବା ଆଣ୍ଟେନାଟି :

(i) ଭୂପୃଷ୍ଠରେ,

(ii) 5 ମିଟର ଉଚ୍ଚତାରେ ରହିଥାନ୍ତି ।

ସ୍ଥିତି (i) ତୁଳନାରେ ସ୍ଥିତି (ii) ରେ ବୃଦ୍ଧି ପାଇଥିବା ଆଣ୍ଟେନା ପରିସର (ରେଞ୍ଜ)  $n\%$  ଅଟେ ।

ନିକଟତମ ପୂର୍ଣ୍ଣସଂଖ୍ୟାରେ  $n$  ର ମୂଲ୍ୟ ହେଉଛି \_\_\_\_\_ ।

**Response Type :** Numeric

**Evaluation Required For SA :** Yes

**Show Word Count :** Yes

**Answers Type :** Equal

**Text Areas :** PlainText

**Possible Answers :**

100

**Question Number :** 30 **Question Id :** 8643516510 **Question Type :** SA

**Correct Marks :** 4 **Wrong Marks :** 0

The radius of a sphere is measured to be  $(7.50 \pm 0.85)$  cm. Suppose the percentage error in its volume is  $x$ .

The value of  $x$ , to the nearest  $x$ , is \_\_\_\_\_.

**Response Type :** Numeric

**Evaluation Required For SA :** Yes

**Show Word Count :** Yes

**Answers Type :** Equal

**Text Areas :** PlainText

**Possible Answers :**

100

**Question Number :** 30 **Question Id :** 8643516510 **Question Type :** SA

**Correct Marks :** 4 **Wrong Marks :** 0

ଗୋଟିଏ ଗୋଲକର ବ୍ୟାସାର୍ଦ୍ଧ  $(7.50 \pm 0.85)$  ସେ.ମି ବୋଲି ମାପ କରାଗଲା । ମନେକର ଏହାର ଆୟତନରେ ଶତକଡ଼ା ତ୍ରୁଟି  $x$  ଅଟେ । ନିକଟତମ ପୂର୍ଣ୍ଣସଂଖ୍ୟାରେ  $x$  ର ମୂଲ୍ୟ ଅଟେ \_\_\_\_\_ ।

**Response Type :** Numeric

**Evaluation Required For SA :** Yes

**Show Word Count :** Yes

**Answers Type :** Equal

**Text Areas :** PlainText

**Possible Answers :**

100

<b>Section Id :</b>	864351435
<b>Section Number :</b>	3
<b>Section type :</b>	Online
<b>Mandatory or Optional :</b>	Mandatory
<b>Number of Questions :</b>	20
<b>Number of Questions to be attempted :</b>	20
<b>Section Marks :</b>	80
<b>Mark As Answered Required? :</b>	Yes
<b>Sub-Section Number :</b>	1
<b>Sub-Section Id :</b>	864351435
<b>Question Shuffling Allowed :</b>	Yes

**Question Number : 31 Question Id : 8643516511 Question Type : MCQ Option Shuffling : Yes Is Question Mandatory : No**

**Correct Marks : 4 Wrong Marks : 1**

A hard substance melts at high temperature and is an insulator in both solid and in molten state. This solid is most likely to be a/an :

**Options :**

86435119531. Ionic solid

86435119532. Covalent solid

86435119533. Metallic solid

86435119534. Molecular solid

**Question Number : 31 Question Id : 8643516511 Question Type : MCQ Option Shuffling : Yes Is Question Mandatory : No**

**Correct Marks : 4 Wrong Marks : 1**

ଏକ ଶକ୍ତ ପଦାର୍ଥ ଉଚ୍ଚ ତାପମାତ୍ରାରେ ତରଳି ଯାଏ ଏବଂ ଏହା କଠିନ ଏବଂ ତରଳ ଉଭୟ ଅବସ୍ଥାରେ ତାପ କୁପରିବାହୀ ଅଟେ ।

**Options :**

86435119531. ଆୟନିକ କଠିନ

86435119532. ସମଯୋଜ୍ୟ କଠିନ

86435119533. ଧାତବ କଠିନ

86435119534. ଆଣବିକ କଠିନ

**Question Number : 32 Question Id : 8643516512 Question Type : MCQ Option Shuffling : Yes Is Question Mandatory : No**

**Correct Marks : 4 Wrong Marks : 1**

Given below are two statements :

**Statement I :** Bohr's theory accounts for the stability and line spectrum of  $\text{Li}^+$  ion.

**Statement II :** Bohr's theory was unable to explain the splitting of spectral lines in the presence of a magnetic field.

In the light of the above statements, choose the most appropriate answer from the options given below :

**Options :**

86435119535. Both statement I and statement II are true.

86435119536. Both statement I and statement II are false.

86435119537. Statement I is true but statement II is false.

86435119538. Statement I is false but statement II is true.

**Question Number : 32 Question Id : 8643516512 Question Type : MCQ Option Shuffling : Yes Is Question Mandatory : No**

**Correct Marks : 4 Wrong Marks : 1**

ନିମ୍ନରେ ଦୁଇଟି ଉକ୍ତି ଦିଆଯାଇଛି :

**ଉକ୍ତି I :** ବୋହରଙ୍କ ତଥ୍ୟ  $\text{Li}^+$  ଆୟନର ସ୍ଥିରତା ଏବଂ ଚୈତ୍ସୁକ ବର୍ଣ୍ଣାଳୀକୁ ବ୍ୟାଖ୍ୟା କରେ ।

**ଉକ୍ତି II :** ବୋହରଙ୍କ ତଥ୍ୟ ଚୁମ୍ବକୀୟ କ୍ଷେତ୍ରର ଉପସ୍ଥିତିରେ ବିଦୀର୍ଣ୍ଣ ବର୍ଣ୍ଣାଳୀ ରେଖା ଗୁଡ଼ିକରୁ ବ୍ୟାଖ୍ୟା କରିବାରେ ଅକ୍ଷମ ଅଟେ ।

ଉପରୋକ୍ତ ଉକ୍ତି ଅନୁସାରେ, ନିମ୍ନ ବିକଳ୍ପ ମଧ୍ୟରୁ ସର୍ବାଧିକ ଉପଯୁକ୍ତ ଉତ୍ତରଟି ବାଛି :

**Options :**

86435119535. ଉଭୟ ଉକ୍ତି I ଏବଂ ଉକ୍ତି II ସତ୍ୟ ଅଟେ ।

86435119536. ଉଭୟ ଉକ୍ତି I ଏବଂ ଉକ୍ତି II ମିଥ୍ୟା ଅଟେ ।

86435119537. ଉକ୍ତି I ସତ୍ୟ କିନ୍ତୁ ଉକ୍ତି II ମିଥ୍ୟା ଅଟେ ।

86435119538. ଉକ୍ତି I ମିଥ୍ୟା କିନ୍ତୁ ଉକ୍ତି II ସତ୍ୟ ଅଟେ ।

**Question Number : 33 Question Id : 8643516513 Question Type : MCQ Option Shuffling : Yes Is Question Mandatory : No**

**Correct Marks : 4 Wrong Marks : 1**

The charges on the colloidal CdS sol and  $\text{TiO}_2$  sol are, respectively :

**Options :**

86435119539. positive and positive
86435119540. negative and positive
86435119541. positive and negative
86435119542. negative and negative

**Question Number : 33 Question Id : 8643516513 Question Type : MCQ Option Shuffling : Yes Is Question Mandatory : No**

**Correct Marks : 4 Wrong Marks : 1**

CdS sol ଏବଂ  $\text{TiO}_2$  sol ରେ କଲିଲର ଚାର୍ଜ ଗୁଡ଼ିକ ଯଥାକ୍ରମେ :

**Options :**

86435119539. ପଜିଟିଭ୍ ଏବଂ ପଜିଟିଭ୍
86435119540. ନେଗେଟିଭ୍ ଏବଂ ପଜିଟିଭ୍
86435119541. ପଜିଟିଭ୍ ଏବଂ ନେଗେଟିଭ୍
86435119542. ନେଗେଟିଭ୍ ଏବଂ ନେଗେଟିଭ୍

**Question Number : 34 Question Id : 8643516514 Question Type : MCQ Option Shuffling : Yes Is Question Mandatory : No**

**Correct Marks : 4 Wrong Marks : 1**

The first ionization energy of magnesium is smaller as compared to that of elements X and Y, but higher than that of Z. The elements X, Y and Z, respectively, are :

**Options :**

86435119543. argon, chlorine and sodium
86435119544. chlorine, lithium and sodium



86435119545. argon, lithium and sodium

86435119546. neon, sodium and chlorine

**Question Number : 34 Question Id : 8643516514 Question Type : MCQ Option Shuffling : Yes Is**

**Question Mandatory : No**

**Correct Marks : 4 Wrong Marks : 1**

ମାଗ୍ନେସିୟମର ପ୍ରଥମ ଆୟନୀକରଣ ଶକ୍ତି ମୌଳିକ X ଏବଂ Y ତୁଳନାରେ କମ୍ କିନ୍ତୁ Z ଠାରୁ ଅଧିକ । ମୌଳିକ X, Y, Z ହେଉଛନ୍ତି :

**Options :**

86435119543. ଆରଗନ, କ୍ଲୋରିନ୍ ଏବଂ ସୋଡ଼ିୟମ୍

86435119544. କ୍ଲୋରିନ୍, ଲିଥିୟମ୍ ଏବଂ ସୋଡ଼ିୟମ୍

86435119545. ଆରଗନ, ଲିଥିୟମ୍ ଏବଂ ସୋଡ଼ିୟମ୍

86435119546. ନିଅନ, ସୋଡ଼ିୟମ୍ ଏବଂ କ୍ଲୋରିନ୍

**Question Number : 35 Question Id : 8643516515 Question Type : MCQ Option Shuffling : Yes Is**

**Question Mandatory : No**

**Correct Marks : 4 Wrong Marks : 1**

**Match List - I with List - II :**

List - I	List - II
(a) Mercury	(i) Vapour phase refining
(b) Copper	(ii) Distillation Refining
(c) Silicon	(iii) Electrolytic Refining
(d) Nickel	(iv) Zone Refining

Choose the most appropriate answer from the option given below :

**Options :**

86435119547. (a)-(ii), (b)-(iii), (c)-(iv), (d)-(i)

86435119548. (a)-(i), (b)-(iv), (c)-(ii), (d)-(iii)

86435119549. (a)-(ii), (b)-(iii), (c)-(i), (d)-(iv)

86435119550. (a)-(ii), (b)-(iv), (c)-(iii), (d)-(i)

**Question Number : 35 Question Id : 8643516515 Question Type : MCQ Option Shuffling : Yes Is Question Mandatory : No**

**Correct Marks : 4 Wrong Marks : 1**

ତାଲିକା - I ସହିତ ତାଲିକା - II ମିଳାଅ :

ତାଲିକା - I	ତାଲିକା - II
(a) ମରକ୍ୟୁରି	(i) ବାଷ୍ପାବସ୍ଥା ବିଶୁଦ୍ଧିକରଣ
(b) କପର	(ii) ପାତନ ବିଶୁଦ୍ଧିକରଣ
(c) ସିଲିକନ୍	(iii) ବୈଦ୍ୟୁତିକ ବିଶୁଦ୍ଧିକରଣ
(d) ନିକେଲ୍	(iv) ଜୋନ୍ ବିଶୁଦ୍ଧିକରଣ

ନିମ୍ନ ବିକଳ୍ପ ମଧ୍ୟରୁ ସର୍ବାଧିକ ଉପଯୁକ୍ତ ଉତ୍ତରଟି ବାଛ :

**Options :**

86435119547. (a)-(ii), (b)-(iii), (c)-(iv), (d)-(i)

86435119548. (a)-(i), (b)-(iv), (c)-(ii), (d)-(iii)

86435119549. (a)-(ii), (b)-(iii), (c)-(i), (d)-(iv)

86435119550. (a)-(ii), (b)-(iv), (c)-(iii), (d)-(i)

**Question Number : 36 Question Id : 8643516516 Question Type : MCQ Option Shuffling : Yes Is Question Mandatory : No**

**Correct Marks : 4 Wrong Marks : 1**

In basic medium,  $H_2O_2$  exhibits which of the following reactions ?

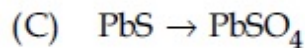
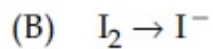
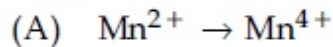

Choose the most appropriate answer from the options given below :

**Options :**

86435119551. (A) only

86435119552. (B) only

86435119553. (A), (B) only

86435119554. (A), (C) only

**Question Number : 36 Question Id : 8643516516 Question Type : MCQ Option Shuffling : Yes Is Question Mandatory : No**

**Correct Marks : 4 Wrong Marks : 1**

ସ୍ଥାୟୀ ମାଧ୍ୟମରେ  $H_2O_2$  ନିମ୍ନଲିଖିତ ପ୍ରତିକ୍ରିୟା ଦର୍ଶାଇଥାଏ ।

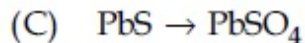
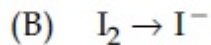
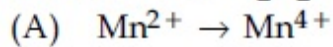

ନିମ୍ନ ବିକଳ୍ପ ମଧ୍ୟରୁ ସର୍ବାଧିକ ଉପଯୁକ୍ତ ଉତ୍ତରଟି ବାଛି :

**Options :**

86435119551. (A) କେବଳ

86435119552. (B) କେବଳ

86435119553. (A), (B) କେବଳ

86435119554. (A), (C) କେବଳ

**Question Number : 37 Question Id : 8643516517 Question Type : MCQ Option Shuffling : Yes Is Question Mandatory : No**

**Correct Marks : 4 Wrong Marks : 1**

**Match List - I with List - II :**

**List - I**

**List - II**

- |        |                                    |
|--------|------------------------------------|
| (a) Be | (i) treatment of cancer            |
| (b) Mg | (ii) extraction of metals          |
| (c) Ca | (iii) incendiary bombs and signals |
| (d) Ra | (iv) windows of X-ray tubes        |
|        | (v) bearings for motor engines.    |

Choose the most appropriate answer from the option given below :

**Options :**

86435119555. (a)-(iv), (b)-(iii), (c)-(ii), (d)-(i)

86435119556. (a)-(iii), (b)-(iv), (c)-(ii), (d)-(v)



86435119557. (a)-(iv), (b)-(iii), (c)-(i), (d)-(ii)

86435119558. (a)-(iii), (b)-(iv), (c)-(v), (d)-(ii)

**Question Number : 37 Question Id : 8643516517 Question Type : MCQ Option Shuffling : Yes Is Question Mandatory : No**

**Correct Marks : 4 Wrong Marks : 1**

ତାଲିକା - I ସହିତ ତାଲିକା - II ମିଳାଅ :

ତାଲିକା - I	ତାଲିକା - II
(a) Be	(i) କେନସରର ଚିକିତ୍ସା
(b) Mg	(ii) ଧାତୁ ନିଷ୍କାସନ
(c) Ca	(iii) ଅଗ୍ନିକାରକ ବୋମା ଏବଂ ସଙ୍କେତ
(d) Ra	(iv) X-ray ନଳୀର ଝରକା
	(v) ମର ଲଞ୍ଜିନ୍ର ବିୟରିଂ

ନିମ୍ନ ବିକଳ୍ପ ମଧ୍ୟରୁ ସର୍ବାଧିକ ଉପଯୁକ୍ତ ଉତ୍ତରଟି ବାଛି :

**Options :**

86435119555. (a)-(iv), (b)-(iii), (c)-(ii), (d)-(i)

86435119556. (a)-(iii), (b)-(iv), (c)-(ii), (d)-(v)

86435119557. (a)-(iv), (b)-(iii), (c)-(i), (d)-(ii)

86435119558. (a)-(iii), (b)-(iv), (c)-(v), (d)-(ii)

**Question Number : 38 Question Id : 8643516518 Question Type : MCQ Option Shuffling : Yes Is Question Mandatory : No**

**Correct Marks : 4 Wrong Marks : 1**

The oxidation states of nitrogen in NO, NO<sub>2</sub>, N<sub>2</sub>O and NO<sub>3</sub><sup>-</sup> are in the order of :

**Options :**

86435119559. NO > NO<sub>2</sub> > N<sub>2</sub>O > NO<sub>3</sub><sup>-</sup>

86435119560. N<sub>2</sub>O > NO<sub>2</sub> > NO > NO<sub>3</sub><sup>-</sup>

86435119561. NO<sub>2</sub> > NO<sub>3</sub><sup>-</sup> > NO > N<sub>2</sub>O

86435119562.  $\text{NO}_3^- > \text{NO}_2 > \text{NO} > \text{N}_2\text{O}$

**Question Number : 38 Question Id : 8643516518 Question Type : MCQ Option Shuffling : Yes Is Question Mandatory : No**

**Correct Marks : 4 Wrong Marks : 1**

NO, NO<sub>2</sub>, N<sub>2</sub>O ଏବଂ NO<sub>3</sub><sup>-</sup> ରେ ନାଇଟ୍ରୋଜେନ୍‌ର ଜାରଣ ଅବସ୍ଥାର କ୍ରମଟି ହେଉଛି :

**Options :**

86435119559.  $\text{NO} > \text{NO}_2 > \text{N}_2\text{O} > \text{NO}_3^-$

86435119560.  $\text{N}_2\text{O} > \text{NO}_2 > \text{NO} > \text{NO}_3^-$

86435119561.  $\text{NO}_2 > \text{NO}_3^- > \text{NO} > \text{N}_2\text{O}$

86435119562.  $\text{NO}_3^- > \text{NO}_2 > \text{NO} > \text{N}_2\text{O}$

**Question Number : 39 Question Id : 8643516519 Question Type : MCQ Option Shuffling : Yes Is Question Mandatory : No**

**Correct Marks : 4 Wrong Marks : 1**

The oxide that shows magnetic property is :

**Options :**

86435119563.  $\text{SiO}_2$

86435119564.  $\text{Mn}_3\text{O}_4$

86435119565.  $\text{MgO}$

86435119566.  $\text{Na}_2\text{O}$

**Question Number : 39 Question Id : 8643516519 Question Type : MCQ Option Shuffling : Yes Is Question Mandatory : No**

**Correct Marks : 4 Wrong Marks : 1**

ତୁମ୍ବକୀୟ ଗୁଣ ଦେଖାଇଥିବା ଅକ୍ସାଇଡ୍‌ଟି ହେଉଛି :

**Options :**

86435119563.  $\text{SiO}_2$

86435119564.  $\text{Mn}_3\text{O}_4$

86435119565.  $\text{MgO}$

86435119566.  $\text{Na}_2\text{O}$

**Question Number : 40 Question Id : 8643516520 Question Type : MCQ Option Shuffling : Yes Is Question Mandatory : No**

**Correct Marks : 4 Wrong Marks : 1**

The secondary valency and the number of hydrogen bonded water molecule(s) in  $\text{CuSO}_4 \cdot 5\text{H}_2\text{O}$ , respectively, are :

**Options :**

86435119567. 4 and 1

86435119568. 6 and 4

86435119569. 5 and 1

86435119570. 6 and 5

**Question Number : 40 Question Id : 8643516520 Question Type : MCQ Option Shuffling : Yes Is Question Mandatory : No**

**Correct Marks : 4 Wrong Marks : 1**

$\text{CuSO}_4 \cdot 5\text{H}_2\text{O}$  ରେ ଦ୍ୱିତୀୟକ ଯୋଜ୍ୟତା ଏବଂ ଉଦ୍ଜାନ ବନ୍ଧିତ ଜଳ ଅଣୁର ସଂଖ୍ୟା ଯଥାକ୍ରମେ ହେଉଛି :

**Options :**

86435119567. 4 ଏବଂ 1

86435119568. 6 ଏବଂ 4

86435119569. 5 ଏବଂ 1

86435119570. 6 ଏବଂ 5

**Question Number : 41 Question Id : 8643516521 Question Type : MCQ Option Shuffling : Yes Is Question Mandatory : No**

**Correct Marks : 4 Wrong Marks : 1**

Given below are two statements :

**Statement I :** Non-biodegradable wastes are generated by the thermal power plants.

**Statement II :** Bio-degradable detergents leads to eutrophication.

In the light of the above statements, choose the most appropriate answer from the options given below :

**Options :**

86435119571. Both statement I and statement II are true.

86435119572. Both statement I and statement II are false.

86435119573. Statement I is true but statement II is false.

86435119574. Statement I is false but statement II is true.

**Question Number : 41 Question Id : 8643516521 Question Type : MCQ Option Shuffling : Yes Is Question Mandatory : No**

**Correct Marks : 4 Wrong Marks : 1**

ନିମ୍ନରେ ଦୁଇଟି ଉକ୍ତି ଦିଆଯାଇଛି :

**ଉକ୍ତି I :** ଚାପଜ ଶକ୍ତି କାରଖାନା ଦ୍ୱାରା ଜୈବ ଅକ୍ଷୟ ରଦ୍ଧି ସୃଷ୍ଟି ହୁଏ ।

**ଉକ୍ତି II :** ଜୈବ କ୍ଷୟ ଅପମାର୍ଜକ ଯୁଗ୍ଠୋପକେସନ୍ କରାଯାଏ ।

ଉପରୋକ୍ତ ଉକ୍ତି ଅନୁସାରେ, ନିମ୍ନଲିଖିତ ବିକଳ୍ପ ମଧ୍ୟରୁ ସର୍ବାଧିକ ଉପଯୁକ୍ତ ଉତ୍ତରଟିକୁ ବାଛି :

**Options :**

86435119571. ଉଭୟ ଉକ୍ତି I ଏବଂ ଉକ୍ତି II ସତ୍ୟ ଅଟେ ।

86435119572. ଉଭୟ ଉକ୍ତି I ଏବଂ ଉକ୍ତି II ମିଥ୍ୟା ଅଟେ ।

86435119573. ଉକ୍ତି I ସତ୍ୟ କିନ୍ତୁ ଉକ୍ତି II ମିଥ୍ୟା ଅଟେ ।

86435119574. ଉକ୍ତି I ମିଥ୍ୟା କିନ୍ତୁ ଉକ୍ତି II ସତ୍ୟ ଅଟେ ।

**Question Number : 42 Question Id : 8643516522 Question Type : MCQ Option Shuffling : Yes Is Question Mandatory : No**

**Correct Marks : 4 Wrong Marks : 1**

Given below are two statements :

**Statement I :**  $C_2H_5OH$  and  $AgCN$  both can generate nucleophile.

**Statement II :**  $KCN$  and  $AgCN$  both will generate nitrile nucleophile with all reaction conditions.

Choose the most appropriate option :

**Options :**

86435119575. Both statement I and statement II are true.

86435119576. Both statement I and statement II are false.

86435119577. Statement I is true but statement II is false.

86435119578. Statement I is false but statement II is true.

**Question Number : 42 Question Id : 8643516522 Question Type : MCQ Option Shuffling : Yes Is Question Mandatory : No**

**Correct Marks : 4 Wrong Marks : 1**

ନିମ୍ନରେ ଦୁଇଟି ଉକ୍ତି ଦିଆଯାଇଛି :

ଉକ୍ତି I :  $C_2H_5OH$  ଏବଂ  $AgCN$  ଉଭୟ ନ୍ୟୁକ୍ଲିଓଫାଇଲ୍ ସୃଷ୍ଟି କରି ପାରିବେ ।

ଉକ୍ତି II : ଉଭୟ  $KCN$  ଏବଂ  $AgCN$  ସବୁ ପ୍ରତିକ୍ରିୟା ସର୍ତ୍ତରେ ନାଇଟ୍ରାଇଲ ନ୍ୟୁକ୍ଲିଓଫାଇଲ୍ ସୃଷ୍ଟି କରିବେ ।

ସର୍ବାଧିକ ଉପଯୁକ୍ତ ଉତ୍ତରଟି ବାଛି :

**Options :**

86435119575. ଉଭୟ ଉକ୍ତି I ଏବଂ ଉକ୍ତି II ସତ୍ୟ ଅଟେ ।

86435119576. ଉଭୟ ଉକ୍ତି I ଏବଂ ଉକ୍ତି II ମିଥ୍ୟା ଅଟେ ।

86435119577. ଉକ୍ତି I ସତ୍ୟ କିନ୍ତୁ ଉକ୍ତି II ମିଥ୍ୟା ଅଟେ ।

86435119578. ଉକ୍ତି I ମିଥ୍ୟା କିନ୍ତୁ ଉକ୍ତି II ସତ୍ୟ ଅଟେ ।

**Question Number : 43 Question Id : 8643516523 Question Type : MCQ Option Shuffling : Yes Is Question Mandatory : No**

**Correct Marks : 4 Wrong Marks : 1**



In the following molecule,

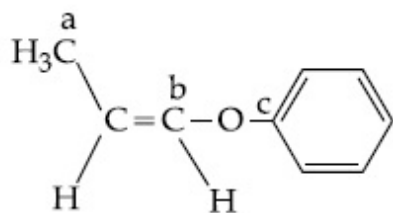

Hybridisation of Carbon a, b and c respectively are :

Options :

86435119579.  $sp^3, sp^2, sp^2$

86435119580.  $sp^3, sp^2, sp$

86435119581.  $sp^3, sp, sp$

86435119582.  $sp^3, sp, sp^2$

Question Number : 43 Question Id : 8643516523 Question Type : MCQ Option Shuffling : Yes Is Question Mandatory : No

Correct Marks : 4 Wrong Marks : 1

ନିମ୍ନଲିଖିତ ଅଣୁରେ କାରବନ a, b, c ର ଶଙ୍କରୀକରଣ ଯଥାକ୍ରମେ ହେଉଛି :

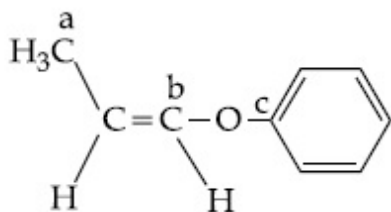

Options :

86435119579.  $sp^3, sp^2, sp^2$

86435119580.  $sp^3, sp^2, sp$

86435119581.  $sp^3, sp, sp$

86435119582.  $sp^3, sp, sp^2$

Question Number : 44 Question Id : 8643516524 Question Type : MCQ Option Shuffling : Yes Is



**Question Mandatory : No**

**Correct Marks : 4 Wrong Marks : 1**

Main Products formed during a reaction of 1-methoxy naphthalene with hydroiodic acid are :

**Options :**

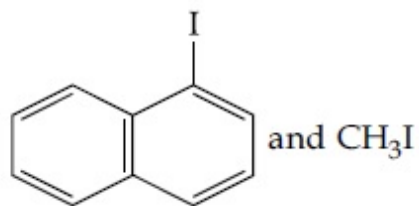

86435119583.

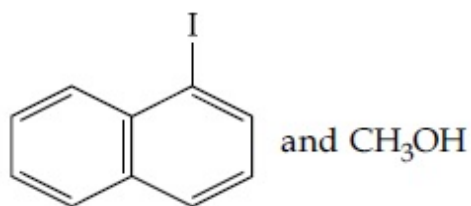

86435119584.

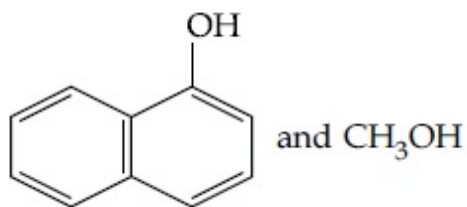

86435119585.

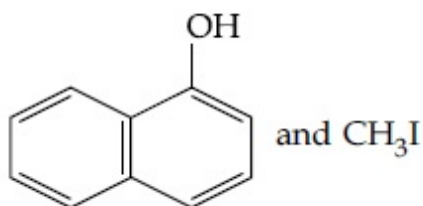

86435119586.

**Question Number : 44 Question Id : 8643516524 Question Type : MCQ Option Shuffling : Yes Is**

**Question Mandatory : No**

**Correct Marks : 4 Wrong Marks : 1**

ହାଇଡ୍ରୋ ଆୟଡିକ୍ ଅମ୍ଳ ସହିତ 1 ମେଥକ୍ସିନାଫଥାଲିନ୍ ପ୍ରତିକ୍ରିୟା ସମୟରେ ଗଠିତ ଉତ୍ପାଦ ଗୁଡ଼ିକ ହେଉଛି :

**Options :**

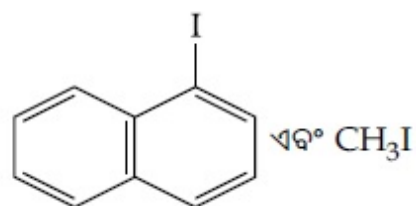

86435119583.

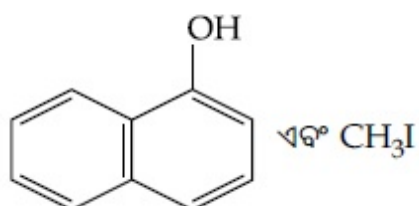
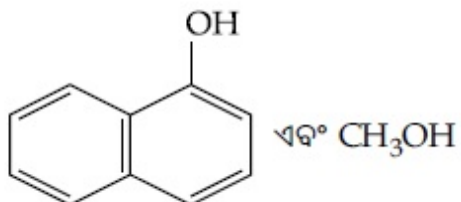
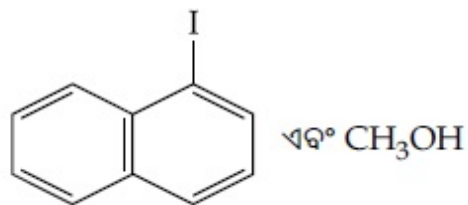

Question Number : 45 Question Id : 8643516525 Question Type : MCQ Option Shuffling : Yes Is Question Mandatory : No Correct Marks : 4 Wrong Marks : 1

In the reaction of hypobromite with amide, the carbonyl carbon is lost as :

Options :

86435119587.  $\text{CO}$

86435119588.  $\text{CO}_2$

86435119589.  $\text{CO}_3^{2-}$

86435119590.  $\text{HCO}_3^-$

Question Number : 45 Question Id : 8643516525 Question Type : MCQ Option Shuffling : Yes Is Question Mandatory : No Correct Marks : 4 Wrong Marks : 1

ଆମାଲଟ୍ ସହିତ ହାଇପୋବ୍ରୋମାଇଟ୍ ପ୍ରତିକ୍ରିୟାରେ ନଷ୍ଟ ହେଉଥିବା କାର୍ବୋନିଲ କାର୍ବନ୍ର ପ୍ରକାର ହେଉଛି :

Options :

86435119587. CO

86435119588. CO<sub>2</sub>86435119589. CO<sub>3</sub><sup>2-</sup>86435119590. HCO<sub>3</sub><sup>-</sup>

Question Number : 46 Question Id : 8643516526 Question Type : MCQ Option Shuffling : Yes Is Question Mandatory : No Correct Marks : 4 Wrong Marks : 1

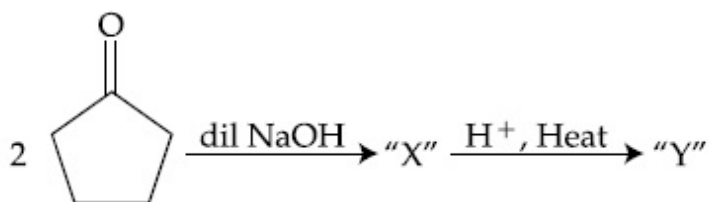

Consider the above reaction, the product 'X' and 'Y' respectively are :

Options :

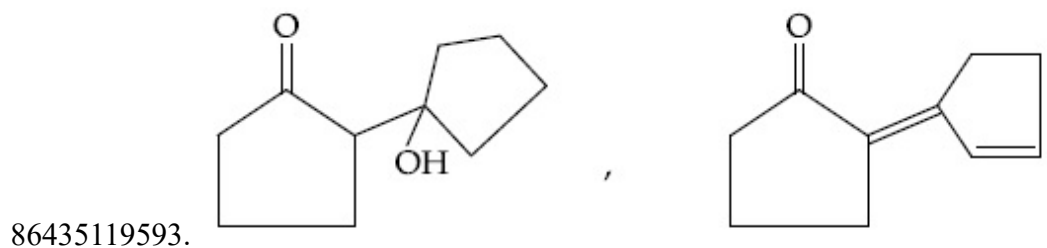
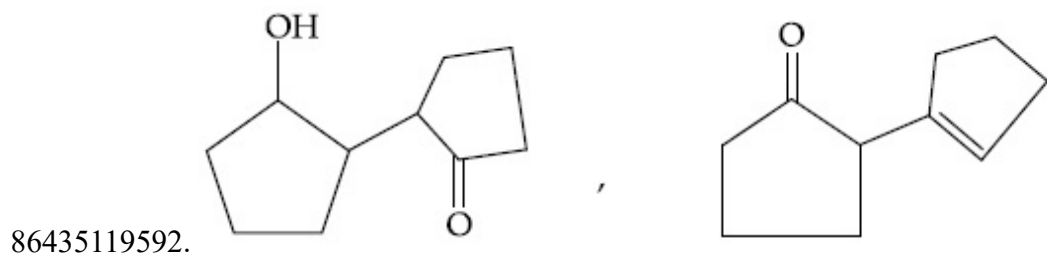
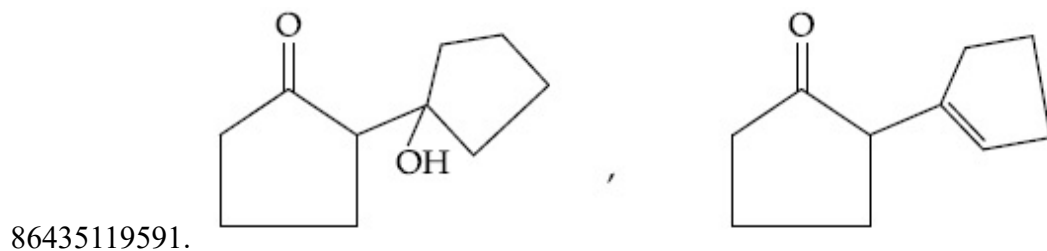

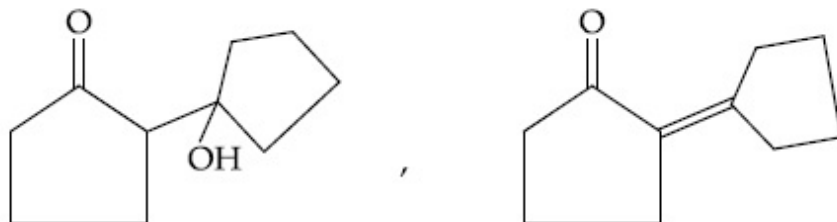

86435119594.

Question Number : 46 Question Id : 8643516526 Question Type : MCQ Option Shuffling : Yes Is Question Mandatory : No

Correct Marks : 4 Wrong Marks : 1

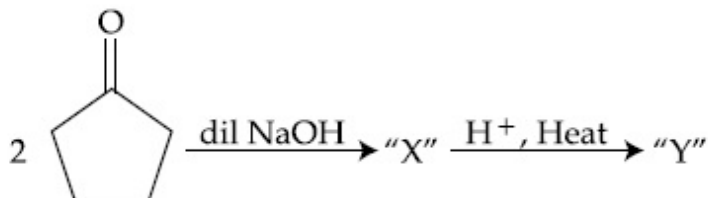

ଉପରୋକ୍ତ ପ୍ରତିକ୍ରିୟାଟିକୁ ବିଚାର କର, ଉତ୍ପାଦ 'X' ଏବଂ 'Y' ଯଥାକ୍ରମେ ହେଉଛି :

Options :

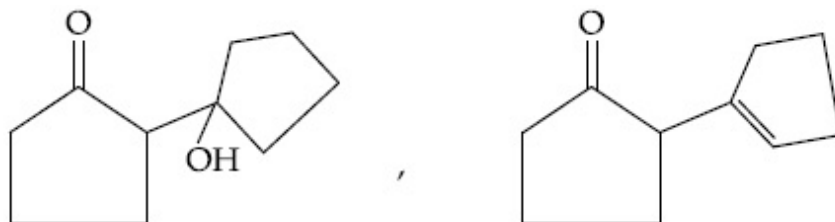

86435119591.

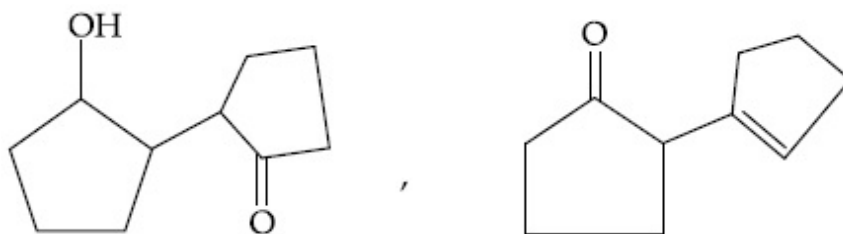

86435119592.

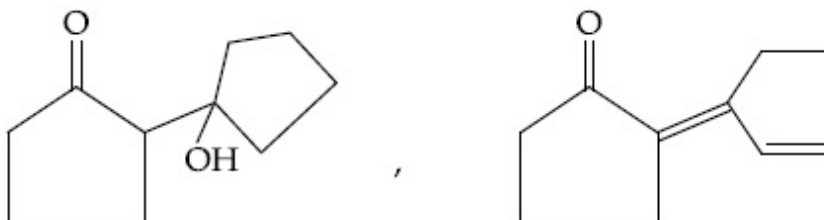

86435119593.

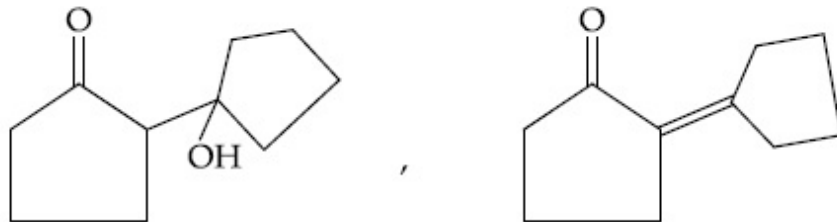

86435119594.

**Question Number : 47 Question Id : 8643516527 Question Type : MCQ Option Shuffling : Yes Is Question Mandatory : No**

**Correct Marks : 4 Wrong Marks : 1**

An organic compound "A" on treatment with benzene sulphonyl chloride gives compound B. B is soluble in dil. NaOH solution. Compound A is :

**Options :**

86435119595.  $C_6H_5 - CH_2 NH CH_3$

86435119596.  $C_6H_5 - N - (CH_3)_2$

86435119597.  $C_6H_5 - NHCH_2CH_3$

86435119598. 
$$C_6H_5 - \underset{\substack{| \\ CH_3}}{CH} - NH_2$$

**Question Number : 47 Question Id : 8643516527 Question Type : MCQ Option Shuffling : Yes Is Question Mandatory : No**

**Correct Marks : 4 Wrong Marks : 1**

ବେଞ୍ଜିନ୍ ସଲଫୋନିଲ୍ କ୍ଲୋରାଇଡ୍ ସହିତ ଏକ ଜୈବ ଯୌଗିକ "A" ପ୍ରତିକ୍ରିୟା କରି ଯୌଗିକ B ଉତ୍ପନ୍ନ କରେ । B, ଲଘୁ NaOHରେ ଦ୍ରବଣୀୟ । ଜୈବ ଯୌଗିକ A ହେଉଛି :

**Options :**

86435119595.  $C_6H_5 - CH_2 NH CH_3$

86435119596.  $C_6H_5 - N - (CH_3)_2$

86435119597.  $C_6H_5 - NHCH_2CH_3$

86435119598. 
$$C_6H_5 - \underset{\substack{| \\ CH_3}}{CH} - NH_2$$





86435119601.  $B > C > A$

86435119602.  $C > B > A$

**Question Number : 49 Question Id : 8643516529 Question Type : MCQ Option Shuffling : Yes Is Question Mandatory : No**

**Correct Marks : 4 Wrong Marks : 1**

Match List - I with List - II :

List - I (Class of Chemicals)	List - II (Example)
(a) Antifertility drug	(i) Meprobamate
(b) Antibiotic	(ii) Alitame
(c) Tranquilizer	(iii) Norethindrone
(d) Artificial Sweetener	(iv) Salvarsan

Choose the most appropriate match :

**Options :**

86435119603. (a)-(iv), (b)-(iii), (c)-(ii), (d)-(i)

86435119604. (a)-(ii), (b)-(iii), (c)-(iv), (d)-(i)

86435119605. (a)-(iii), (b)-(iv), (c)-(i), (d)-(ii)

86435119606. (a)-(ii), (b)-(iv), (c)-(i), (d)-(iii)

**Question Number : 49 Question Id : 8643516529 Question Type : MCQ Option Shuffling : Yes Is Question Mandatory : No**

**Correct Marks : 4 Wrong Marks : 1**

ତାଲିକା - I ସହିତ ତାଲିକା - II ମିଳାଅ :

ତାଲିକା - I (ରାସାୟନିକ ଶ୍ରେଣୀ)	ତାଲିକା - II (ଦୃଷ୍ଟାନ୍ତ)
(a) ଅନୁର୍ବରତା ଔଷଧ	(i) ମେପ୍ରୋବାମେଟ୍
(b) ପ୍ରତିଜୈବିକ	(ii) ଆଲିଟାମେ
(c) ନିଶ୍ଚଳକାରକ	(iii) ନୋରେଥିନ୍ଡ୍ରୋନ୍
(d) କୃତ୍ରିମ ମଧୁରକ	(iv) ସାଲଭାର୍ସାନ୍

ନିମ୍ନ ବିକଳ୍ପ ମଧ୍ୟରୁ ସର୍ବାଧିକ ଉପଯୁକ୍ତ ମୋଳକଟିକୁ ବାଛ :

**Options :**

86435119603. (a)-(iv), (b)-(iii), (c)-(ii), (d)-(i)

86435119604. (a)-(ii), (b)-(iii), (c)-(iv), (d)-(i)

86435119605. (a)-(iii), (b)-(iv), (c)-(i), (d)-(ii)

86435119606. (a)-(ii), (b)-(iv), (c)-(i), (d)-(iii)

**Question Number : 50 Question Id : 8643516530 Question Type : MCQ Option Shuffling : Yes Is**

**Question Mandatory : No**

**Correct Marks : 4 Wrong Marks : 1**

Deficiency of vitamin K causes :

**Options :**

86435119607. Increase in blood clotting time

86435119608. Decrease in blood clotting time

86435119609. Cheilosis

86435119610. Increase in fragility of RBC's

**Question Number : 50 Question Id : 8643516530 Question Type : MCQ Option Shuffling : Yes Is**

**Question Mandatory : No**

**Correct Marks : 4 Wrong Marks : 1**

ଭିଟାମିନ୍ K ର ଅଭାବ କରାଏ :

**Options :**

86435119607. ରକ୍ତ ଜମାଟ ବାନ୍ଧିବାର ସମୟ ବଢ଼ିଯିବାର

86435119608. ରକ୍ତ ଜମାଟ ବାନ୍ଧିବାର ସମୟ କମିଯିବାର

86435119609. କିଲୋସିସ୍

86435119610. ଆରବିସିର ଭଙ୍ଗପ୍ରବଣତା ବୃଦ୍ଧି

## Chemistry Section B

Section Id :	864351436
Section Number :	4
Section type :	Online
Mandatory or Optional :	Mandatory
Number of Questions :	10
Number of Questions to be attempted :	5
Section Marks :	20
Mark As Answered Required? :	Yes
Sub-Section Number :	1
Sub-Section Id :	864351436
Question Shuffling Allowed :	Yes

Question Number : 51 Question Id : 8643516531 Question Type : SA

Correct Marks : 4 Wrong Marks : 0

10.0 mL of  $\text{Na}_2\text{CO}_3$  solution is titrated against 0.2 M HCl solution. The following titre values were obtained in 5 readings :

4.8 mL, 4.9 mL, 5.0 mL, 5.0 mL and 5.0 mL.

Based on these readings, and convention of titrimetric estimation the concentration of  $\text{Na}_2\text{CO}_3$  solution is \_\_\_\_\_ mM.

(Round off to the Nearest Integer).

Response Type : Numeric

Evaluation Required For SA : Yes

Show Word Count : Yes

Answers Type : Equal

Text Areas : PlainText

Possible Answers :

100

Question Number : 51 Question Id : 8643516531 Question Type : SA

Correct Marks : 4 Wrong Marks : 0

10.0 mL  $\text{Na}_2\text{CO}_3$  ଦ୍ରବଣ 0.2 M HCl ବିପକ୍ଷରେ ଅନୁମାପନ କର । ନିମ୍ନଲିଖିତ ଅନୁମାପନ ମୂଲ୍ୟ ପାଞ୍ଚ ପଠନରେ ମିଳିଲା  
4.8 mL, 4.9 mL, 5.0 mL, 5.0 mL ଏବଂ 5.0 mL ।

ଏହି ପଠନ ଏବଂ ଅନୁମାପନର ଆକଳନର କନ୍ଢେନ୍ସନ ଅନୁଯାୟୀ  $\text{Na}_2\text{CO}_3$  ଦ୍ରବଣର ଗାଢତା ହେଉଛି  
\_\_\_\_\_ mM ।

(ନିକଟତମ ପୂର୍ଣ୍ଣସଂଖ୍ୟାରେ ପରିଣତ କର)

Response Type : Numeric

Evaluation Required For SA : Yes

Show Word Count : Yes

Answers Type : Equal

Text Areas : PlainText

**Possible Answers :**

100

**Question Number : 52 Question Id : 8643516532 Question Type : SA****Correct Marks : 4 Wrong Marks : 0**

The number of species below that have two lone pairs of electrons in their central atom is \_\_\_\_\_ . (Round off to the Nearest Integer).

$SF_4$ ,  $BF_4^-$ ,  $ClF_3$ ,  $AsF_3$ ,  $PCl_5$ ,  $BrF_5$ ,  $XeF_4$ ,  $SF_6$

**Response Type : Numeric****Evaluation Required For SA : Yes****Show Word Count : Yes****Answers Type : Equal****Text Areas : PlainText****Possible Answers :**

100

**Question Number : 52 Question Id : 8643516532 Question Type : SA****Correct Marks : 4 Wrong Marks : 0**

ନିମ୍ନରେ ଥିବା ଅଣୁଗୁଡ଼ିକ ମଧ୍ୟରୁ ସେମାନଙ୍କର କେନ୍ଦ୍ରୀୟ ପରମାଣୁରେ ଥିବା ଦୁଇ ନିଃସଙ୍ଗ ଇଲେକ୍ଟ୍ରନ୍ ଯୋଡ଼ା ଥିବା ଅଣୁ ସଂଖ୍ୟା ହେଉଛି \_\_\_\_\_ ।

(ନିକଟତମ ପୂର୍ଣ୍ଣସଂଖ୍ୟାରେ ପରିଣତ କର)

$SF_4$ ,  $BF_4^-$ ,  $ClF_3$ ,  $AsF_3$ ,  $PCl_5$ ,  $BrF_5$ ,  $XeF_4$ ,  $SF_6$

**Response Type : Numeric****Evaluation Required For SA : Yes****Show Word Count : Yes****Answers Type : Equal****Text Areas : PlainText****Possible Answers :**

100

**Question Number : 53 Question Id : 8643516533 Question Type : SA****Correct Marks : 4 Wrong Marks : 0**

The gas phase reaction

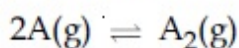

at 400 K has  $\Delta G^\circ = +25.2 \text{ kJ mol}^{-1}$ .

The equilibrium constant  $K_C$  for this reaction is \_\_\_\_\_  $\times 10^{-2}$ . (Round off to the Nearest Integer).

[Use :  $R = 8.3 \text{ J mol}^{-1} \text{ K}^{-1}$ ,  $\ln 10 = 2.3$

$\log_{10} 2 = 0.30$ ,  $1 \text{ atm} = 1 \text{ bar}$ ]

[antilog  $(-0.3) = 0.501$ ]

**Response Type :** Numeric

**Evaluation Required For SA :** Yes

**Show Word Count :** Yes

**Answers Type :** Equal

**Text Areas :** PlainText

**Possible Answers :**

100

**Question Number : 53 Question Id : 8643516533 Question Type : SA**

**Correct Marks : 4 Wrong Marks : 0**

400 K ତାପମାତ୍ରାରେ ଗ୍ୟାସୀୟ ପ୍ରତିକ୍ରିୟାର  $2A(g) \rightleftharpoons A_2(g)$ ,  $\Delta G^\circ = +25.2 \text{ kJ mol}^{-1}$

ଉକ୍ତ ପ୍ରତିକ୍ରିୟାର ସାମ୍ୟ ସ୍ଥିରାଙ୍କ  $K_C$  ହେଉଛି \_\_\_\_\_  $\times 10^{-2}$  ।

(ନିକଟତମ ପୂର୍ଣ୍ଣସଂଖ୍ୟାରେ ପରିଣତ କର)

[Use :  $R = 8.3 \text{ J mol}^{-1} \text{ K}^{-1}$ ,  $\ln 10 = 2.3$

$\log_{10} 2 = 0.30$ ,  $1 \text{ atm} = 1 \text{ bar}$ ]

[antilog  $(-0.3) = 0.501$ ]

**Response Type :** Numeric

**Evaluation Required For SA :** Yes

**Show Word Count :** Yes

**Answers Type :** Equal

**Text Areas :** PlainText

**Possible Answers :**

100

**Question Number : 54 Question Id : 8643516534 Question Type : SA**

**Correct Marks : 4 Wrong Marks : 0**

A solute A dimerizes in water. The boiling point of a 2 molal solution of A is  $100.52^\circ\text{C}$ . The percentage association of A is \_\_\_\_\_. (Round off to the Nearest Integer).

[Use :  $K_b$  for water =  $0.52 \text{ K kg mol}^{-1}$

Boiling point of water =  $100^\circ\text{C}$ ]



**Response Type :** Numeric

**Evaluation Required For SA :** Yes

**Show Word Count :** Yes

**Answers Type :** Equal

**Text Areas :** PlainText

**Possible Answers :**

100

**Question Number : 54 Question Id : 8643516534 Question Type : SA**

**Correct Marks : 4 Wrong Marks : 0**

ଏକ ଦ୍ରାବ୍ୟ A ଜଳରେ ତାପମୋଚିକରଣ ହୁଏ । 2 ମୋଲାର୍ A ଦ୍ରବଣର ସ୍ଥିତନାଙ୍କ  $100.52^{\circ}\text{C}$  । A ର ଏକତ୍ରିତକରଣ ଶତକଡ଼ା ହେଉଛି \_\_\_\_\_ ।

(ନିକଟତମ ପୂର୍ଣ୍ଣସଂଖ୍ୟାରେ ପରିଣତ କର)

[Use :  $K_b$  for water =  $0.52 \text{ K kg mol}^{-1}$

ଜଳର ସ୍ଥିତନାଙ୍କ =  $100^{\circ}\text{C}$ ]

**Response Type :** Numeric

**Evaluation Required For SA :** Yes

**Show Word Count :** Yes

**Answers Type :** Equal

**Text Areas :** PlainText

**Possible Answers :**

100

**Question Number : 55 Question Id : 8643516535 Question Type : SA**

**Correct Marks : 4 Wrong Marks : 0**

The solubility of  $\text{CdSO}_4$  in water is  $8.0 \times 10^{-4} \text{ mol L}^{-1}$ . Its solubility in  $0.01 \text{ M H}_2\text{SO}_4$  solution is \_\_\_\_\_  $\times 10^{-6} \text{ mol L}^{-1}$ . (Round off to the Nearest Integer).

(Assume that solubility is much less than  $0.01 \text{ M}$ )

**Response Type :** Numeric

**Evaluation Required For SA :** Yes

**Show Word Count :** Yes

**Answers Type :** Equal

**Text Areas :** PlainText

**Possible Answers :**

100

**Question Number : 55 Question Id : 8643516535 Question Type : SA**

**Correct Marks : 4 Wrong Marks : 0**



$\text{CdSO}_4$  ର ଜଳୀୟ ଦ୍ରବଣୀୟତା ହେଉଛି  $8.0 \times 10^{-4} \text{ mol L}^{-1}$  ।  $0.01 \text{ M H}_2\text{SO}_4$  ଦ୍ରବଣରେ ଏହାର ଦ୍ରବଣୀୟତା ହେଉଛି \_\_\_\_\_  $\times 10^{-6} \text{ mol L}^{-1}$  ।  
(ନିକଟତମ ପୂର୍ଣ୍ଣସଂଖ୍ୟାରେ ପରିଣତ କର)  
(ଦ୍ରବଣୀୟତା  $0.01 \text{ M}$  ରୁ ଯଥେଷ୍ଟ କମ୍ ଗ୍ରହଣ କର)

**Response Type :** Numeric

**Evaluation Required For SA :** Yes

**Show Word Count :** Yes

**Answers Type :** Equal

**Text Areas :** PlainText

**Possible Answers :**

100

**Question Number : 56 Question Id : 8643516536 Question Type : SA**

**Correct Marks : 4 Wrong Marks : 0**

The molar conductivities at infinite dilution of barium chloride, sulphuric acid and hydrochloric acid are 280, 860 and 426  $\text{S cm}^2 \text{ mol}^{-1}$  respectively. The molar conductivity at infinite dilution of barium sulphate is \_\_\_\_\_  $\text{S cm}^2 \text{ mol}^{-1}$ . (Round off to the Nearest Integer).

**Response Type :** Numeric

**Evaluation Required For SA :** Yes

**Show Word Count :** Yes

**Answers Type :** Equal

**Text Areas :** PlainText

**Possible Answers :**

100

**Question Number : 56 Question Id : 8643516536 Question Type : SA**

**Correct Marks : 4 Wrong Marks : 0**

ଅସୀମ ଲଘୁକରଣରେ ବେରିଅମ୍ କ୍ଲୋରାଇଡ୍, ସଲଫ୍ୟୁରିକ୍ ଅମ୍ଳ ଏବଂ ହାଇଡ୍ରୋକ୍ଲୋରିକ୍ ଅମ୍ଳଗୁଡ଼ିକର ମୋଲାର ପରିବାହିତା ହେଉଛି ଯଥାକ୍ରମେ 280, 860 ଏବଂ 426  $\text{S cm}^2 \text{ mol}^{-1}$  । ଅସୀମ ଲଘୁକରଣରେ ବେରିଅମ୍ ସଲଫେଟର ମୋଲାର ପରିବାହିତା ହେଉଛି \_\_\_\_\_  $\text{S cm}^2 \text{ mol}^{-1}$  ।  
(ନିକଟତମ ପୂର୍ଣ୍ଣସଂଖ୍ୟାରେ ପରିଣତ କର)

**Response Type :** Numeric

**Evaluation Required For SA :** Yes

**Show Word Count :** Yes

**Answers Type :** Equal

**Text Areas :** PlainText

**Possible Answers :**

100

**Question Number : 57 Question Id : 8643516537 Question Type : SA**

**Correct Marks : 4 Wrong Marks : 0**

A reaction has a half life of 1 min. The time required for 99.9% completion of the reaction is \_\_\_\_\_ min. (Round off to the Nearest Integer).

[Use :  $\ln 2 = 0.69$ ;  $\ln 10 = 2.3$ ]

**Response Type : Numeric**

**Evaluation Required For SA : Yes**

**Show Word Count : Yes**

**Answers Type : Equal**

**Text Areas : PlainText**

**Possible Answers :**

100

**Question Number : 57 Question Id : 8643516537 Question Type : SA**

**Correct Marks : 4 Wrong Marks : 0**

ଏକ ପ୍ରତିକ୍ରିୟାର ଅର୍ଦ୍ଧ-ଆୟୁ 1 min ପ୍ରତିକ୍ରିୟାଟି 99.9% ସମ୍ପୂର୍ଣ୍ଣ ହେବା ପାଇଁ ଆବଶ୍ୟକ ସମୟ \_\_\_\_\_ min ।  
(ନିକଟତମ ପୂର୍ଣ୍ଣସଂଖ୍ୟାରେ ପରିଣତ କର)

[Use :  $\ln 2 = 0.69$ ;  $\ln 10 = 2.3$ ]

**Response Type : Numeric**

**Evaluation Required For SA : Yes**

**Show Word Count : Yes**

**Answers Type : Equal**

**Text Areas : PlainText**

**Possible Answers :**

100

**Question Number : 58 Question Id : 8643516538 Question Type : SA**

**Correct Marks : 4 Wrong Marks : 0**

A xenon compound 'A' upon partial hydrolysis gives  $\text{XeO}_2\text{F}_2$ . The number of lone pair of electrons present in compound A is \_\_\_\_\_. (Round off to the Nearest Integer)

**Response Type : Numeric**

**Evaluation Required For SA : Yes**

**Show Word Count : Yes**

**Answers Type : Equal**

**Text Areas : PlainText**

**Possible Answers :**

100

**Question Number : 58 Question Id : 8643516538 Question Type : SA**

**Correct Marks : 4 Wrong Marks : 0**

ଏକ ଜେନର୍ ଯୌଗିକ 'A' ଆଂଶିକ ଜଳ ବିଘଟନ ଦ୍ୱାରା  $XeO_2F_2$  ଉତ୍ପନ୍ନ କରେ । ଯୌଗିକ A ରେ ଥିବା ନିଃସଙ୍ଗ ଇଲେକ୍ଟ୍ରନ୍ ଯୋଡ଼ା ସଂଖ୍ୟା ହେଉଛି \_\_\_\_\_ ।  
(ନିକଟତମ ପୂର୍ଣ୍ଣସଂଖ୍ୟାରେ ପରିଣତ କର)

**Response Type :** Numeric

**Evaluation Required For SA :** Yes

**Show Word Count :** Yes

**Answers Type :** Equal

**Text Areas :** PlainText

**Possible Answers :**

100

**Question Number :** 59 **Question Id :** 8643516539 **Question Type :** SA

**Correct Marks :** 4 **Wrong Marks :** 0

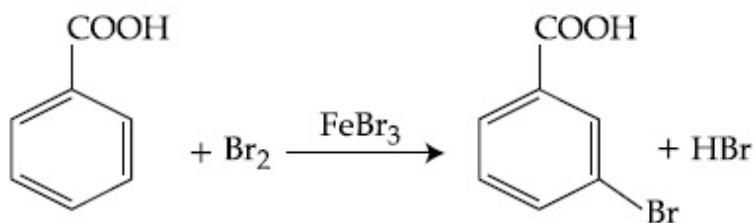

Consider the above reaction where 6.1 g of Benzoic acid is used to get 7.8 g of m-bromo benzoic acid. The percentage yield of the product is \_\_\_\_\_.

(Round off to the Nearest Integer).

[Given : Atomic masses : C : 12.0 u, H : 1.0 u, O : 16.0 u, Br : 80.0 u]

**Response Type :** Numeric

**Evaluation Required For SA :** Yes

**Show Word Count :** Yes

**Answers Type :** Equal

**Text Areas :** PlainText

**Possible Answers :**

100

**Question Number :** 59 **Question Id :** 8643516539 **Question Type :** SA

**Correct Marks :** 4 **Wrong Marks :** 0

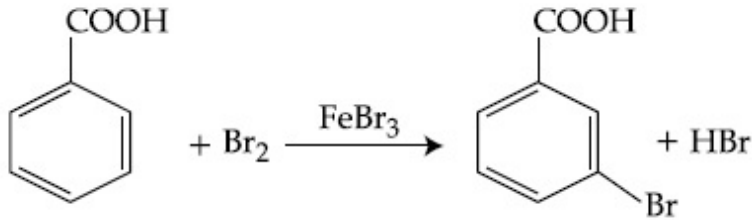

ଉପରୋକ୍ତ ପ୍ରତିକ୍ରିୟାଟିକୁ ବିଚାର କର, ଯେଉଁଠି 6.1 g ବେଞ୍ଜୋଇକ୍ ଅମ୍ଳ ବ୍ୟବହାର କରିବା ଦ୍ୱାରା 7.8 g m-ବ୍ରୋମୋ ବେଞ୍ଜୋଇକ୍ ଅମ୍ଳ ମିଳିଥାଏ । ଉତ୍ପାଦର ଉତ୍ପାଦନ ଶତକଡ଼ା ହେଉଛି \_\_\_\_\_ ।  
 (ନିକଟତମ ପୂର୍ଣ୍ଣସଂଖ୍ୟାରେ ପରିଣତ କର)  
 (ଦତ୍ତ : ପାରମାଣବିକ ବସ୍ତୁତ୍ୱ C : 12.0 u, H : 1.0 u, O : 16.0 u, Br : 80.0 u )

**Response Type :** Numeric

**Evaluation Required For SA :** Yes

**Show Word Count :** Yes

**Answers Type :** Equal

**Text Areas :** PlainText

**Possible Answers :**

100

**Question Number :** 60 **Question Id :** 8643516540 **Question Type :** SA

**Correct Marks :** 4 **Wrong Marks :** 0

In Tollen's test for aldehyde, the overall number of electron(s) transferred to the Tollen's reagent formula  $[\text{Ag}(\text{NH}_3)_2]^+$  per aldehyde group to form silver mirror is \_\_\_\_\_.  
 (Round off to the Nearest Integer).

**Response Type :** Numeric

**Evaluation Required For SA :** Yes

**Show Word Count :** Yes

**Answers Type :** Equal

**Text Areas :** PlainText

**Possible Answers :**

100

**Question Number :** 60 **Question Id :** 8643516540 **Question Type :** SA

**Correct Marks :** 4 **Wrong Marks :** 0

ଆଲଡିହାଇଡ୍ ପାଇଁ ଟଲେନ ପରୀକ୍ଷାରେ ରୂପା ଦର୍ପଣ ଗଠନ କରିବା ପାଇଁ ଟଲେନ ଅଭିକର୍ଷକ  $[\text{Ag}(\text{NH}_3)_2]^+$  କୁ ସ୍ଥାନାନ୍ତର ହୋଇଥିବା ମୋଟାମୋଟି ଇଲେକ୍ଟ୍ରନ୍ ସଂଖ୍ୟା ପ୍ରତି ଆଲଡିହାଇଡ୍ ଗ୍ରୁପ୍ ପାଇଁ ହେଉଛି \_\_\_\_\_ ।  
 (ନିକଟତମ ପୂର୍ଣ୍ଣସଂଖ୍ୟାରେ ପରିଣତ କର)

**Response Type :** Numeric

**Evaluation Required For SA :** Yes

**Show Word Count :** Yes

**Answers Type :** Equal

**Text Areas :** PlainText

**Possible Answers :**

100

## Mathematics Section A

<b>Section Id :</b>	864351437
<b>Section Number :</b>	5
<b>Section type :</b>	Online
<b>Mandatory or Optional :</b>	Mandatory
<b>Number of Questions :</b>	20
<b>Number of Questions to be attempted :</b>	20
<b>Section Marks :</b>	80
<b>Mark As Answered Required? :</b>	Yes
<b>Sub-Section Number :</b>	1
<b>Sub-Section Id :</b>	864351437
<b>Question Shuffling Allowed :</b>	Yes

**Question Number : 61 Question Id : 8643516541 Question Type : MCQ Option Shuffling : Yes Is Question Mandatory : No**

**Correct Marks : 4 Wrong Marks : 1**

If  $15\sin^4\alpha + 10\cos^4\alpha = 6$ , for some  $\alpha \in \mathbb{R}$ , then the value of  $27\sec^6\alpha + 8\operatorname{cosec}^6\alpha$  is equal to :

**Options :**

86435119621. 500

86435119622. 400

86435119623. 350

86435119624. 250

**Question Number : 61 Question Id : 8643516541 Question Type : MCQ Option Shuffling : Yes Is Question Mandatory : No**

**Correct Marks : 4 Wrong Marks : 1**

ଯଦି  $15\sin^4\alpha + 10\cos^4\alpha = 6$ , (କେତେକ  $\alpha \in \mathbb{R}$  ପାଇଁ), ତେବେ  $27\sec^6\alpha + 8\operatorname{cosec}^6\alpha$  ର ମୂଲ୍ୟ ସମାନ :

**Options :**

86435119621. 500

86435119622. 400



86435119623. 350

86435119624. 250

**Question Number : 62 Question Id : 8643516542 Question Type : MCQ Option Shuffling : Yes Is Question Mandatory : No**

**Correct Marks : 4 Wrong Marks : 1**

If P and Q are two statements, then which of the following compound statement is a tautology ?

**Options :**

86435119625.  $((P \Rightarrow Q) \wedge \sim Q) \Rightarrow P$ 86435119626.  $((P \Rightarrow Q) \wedge \sim Q) \Rightarrow Q$ 86435119627.  $((P \Rightarrow Q) \wedge \sim Q) \Rightarrow \sim P$ 86435119628.  $((P \Rightarrow Q) \wedge \sim Q) \Rightarrow (P \wedge Q)$ 

**Question Number : 62 Question Id : 8643516542 Question Type : MCQ Option Shuffling : Yes Is Question Mandatory : No**

**Correct Marks : 4 Wrong Marks : 1**

ଯଦି P ଏବଂ Q ଦୁଇଟି କଥନ ହୁଅନ୍ତି, ତେବେ ନିମ୍ନ ଯୌଗିକ କଥନ ମଧ୍ୟରୁ କେଉଁଟି ଏକ ପୁନରୁକ୍ତି(ତଟୋଲୋଜି) ଅଟେ ?

**Options :**

86435119625.  $((P \Rightarrow Q) \wedge \sim Q) \Rightarrow P$ 86435119626.  $((P \Rightarrow Q) \wedge \sim Q) \Rightarrow Q$ 86435119627.  $((P \Rightarrow Q) \wedge \sim Q) \Rightarrow \sim P$ 86435119628.  $((P \Rightarrow Q) \wedge \sim Q) \Rightarrow (P \wedge Q)$ 

**Question Number : 63 Question Id : 8643516543 Question Type : MCQ Option Shuffling : Yes Is Question Mandatory : No**

**Correct Marks : 4 Wrong Marks : 1**



A pole stands vertically inside a triangular park ABC. Let the angle of elevation of the top of the pole from each corner of the park be  $\frac{\pi}{3}$ . If the radius of the circumcircle of  $\Delta ABC$  is 2,

then the height of the pole is equal to :

**Options :**

86435119629.  $\frac{2\sqrt{3}}{3}$

86435119630.  $2\sqrt{3}$

86435119631.  $\frac{1}{\sqrt{3}}$

86435119632.  $\sqrt{3}$

**Question Number : 63 Question Id : 8643516543 Question Type : MCQ Option Shuffling : Yes Is Question Mandatory : No**

**Correct Marks : 4 Wrong Marks : 1**

ଏକ ତ୍ରିଭୁଜାକାର ପାର୍କ ABC ମଧ୍ୟରେ ଏକ ଖମ୍ବ ଭୂଲମ୍ବ ହୋଇ ଛିଡ଼ା ହୋଇଛି । ମାନି ନିଅ ପାର୍କର ପ୍ରତ୍ୟେକ କୋଣରୁ ଖମ୍ବର ଶୀର୍ଷର ଆନତ (ଉତ୍ତୋଳନ) କୋଣର ପରିମାଣ  $\frac{\pi}{3}$  । ଯଦି ତ୍ରିଭୁଜ ABC ର ପରିବୃତ୍ତର ବ୍ୟାସାର୍ଦ୍ଧ 2 ହୁଏ, ତେବେ ଖମ୍ବଟିର ଉଚ୍ଚତା ସମାନ :

**Options :**

86435119629.  $\frac{2\sqrt{3}}{3}$

86435119630.  $2\sqrt{3}$

86435119631.  $\frac{1}{\sqrt{3}}$

86435119632.  $\sqrt{3}$

**Question Number : 64 Question Id : 8643516544 Question Type : MCQ Option Shuffling : Yes Is**

**Question Mandatory : No**

**Correct Marks : 4 Wrong Marks : 1**

Let in a series of  $2n$  observations, half of them are equal to  $a$  and remaining half are equal to  $-a$ . Also by adding a constant  $b$  in each of these observations, the mean and standard deviation of new set become 5 and 20, respectively. Then the value of  $a^2 + b^2$  is equal to :

**Options :**

86435119633. 925

86435119634. 425

86435119635. 650

86435119636. 250

**Question Number : 64 Question Id : 8643516544 Question Type : MCQ Option Shuffling : Yes Is**

**Question Mandatory : No**

**Correct Marks : 4 Wrong Marks : 1**

ମାନିନିଅ  $2n$  ପର୍ଯ୍ୟବେକ୍ଷଣ ଶୃଙ୍ଖଳା ଶ୍ରେଣୀରେ ଅଧା ପର୍ଯ୍ୟବେକ୍ଷଣର ମୂଲ୍ୟ  $a$  ସହ ସମାନ ଏବଂ ଅବଶିଷ୍ଟ ଅଧା (ଅର୍ଦ୍ଧେକ) ର ମୂଲ୍ୟ  $-a$  ସହ ସମାନ । ପୁନଶ୍ଚ ପ୍ରତ୍ୟେକ ପର୍ଯ୍ୟବେକ୍ଷଣଗୁଡ଼ିକରେ ଏକ ସ୍ଥିରାଙ୍କ  $b$  ଯୋଗକଲେ, ସେହି ନୂଆ ସେଟର ମଧ୍ୟମାନ (ମିନ) ଏବଂ ସାଧାରଣ ବିଚ୍ୟୁତି (ଷ୍ଟାଣ୍ଡାର୍ଡ ଡେଭିଏସନ୍) ଯଥାକ୍ରମେ 5 ଏବଂ 20 ହୁଏ । ତେବେ  $a^2 + b^2$  ର ମୂଲ୍ୟ ସମାନ :

**Options :**

86435119633. 925

86435119634. 425

86435119635. 650

86435119636. 250

**Question Number : 65 Question Id : 8643516545 Question Type : MCQ Option Shuffling : Yes Is**

**Question Mandatory : No**

**Correct Marks : 4 Wrong Marks : 1**

Let in a Binomial distribution, consisting of 5 independent trials, probabilities of exactly 1 and 2 successes be 0.4096 and 0.2048 respectively. Then the probability of getting exactly 3 successes is equal to :

**Options :**

$$86435119637. \frac{40}{243}$$

$$86435119638. \frac{80}{243}$$

$$86435119639. \frac{128}{625}$$

$$86435119640. \frac{32}{625}$$

**Question Number : 65 Question Id : 8643516545 Question Type : MCQ Option Shuffling : Yes Is Question Mandatory : No**

**Correct Marks : 4 Wrong Marks : 1**

ମାନନିଅ ଏକ ଦ୍ଵିପଦ ବଞ୍ଚନରେ 5 ଟି ସ୍ଵତନ୍ତ୍ର ପରିଣାମ ଅଛି, ଠିକ୍ ଗୋଟିଏ ଏବଂ ଦୁଇଟି ସଫଳତା ପାଇବାର ସମ୍ଭାବ୍ୟତା ଯଥାକ୍ରମେ 0.4096 ଏବଂ 0.2048 । ତେବେ ଠିକ୍ ତିନୋଟି ସଫଳତା ପାଇବାର ସମ୍ଭାବ୍ୟତା ସମାନ :

**Options :**

$$86435119637. \frac{40}{243}$$

$$86435119638. \frac{80}{243}$$

$$86435119639. \frac{128}{625}$$

$$86435119640. \frac{32}{625}$$

**Question Number : 66 Question Id : 8643516546 Question Type : MCQ Option Shuffling : Yes Is Question Mandatory : No**

**Correct Marks : 4 Wrong Marks : 1**

In a triangle ABC, if  $|\vec{BC}| = 8$ ,  $|\vec{CA}| = 7$ ,  $|\vec{AB}| = 10$ , then the projection of the vector  $\vec{AB}$  on  $\vec{AC}$  is equal to :

**Options :**

$$86435119641. \frac{115}{16}$$

$$86435119642. \frac{85}{14}$$

$$86435119643. \frac{127}{20}$$

$$86435119644. \frac{25}{4}$$

**Question Number : 66 Question Id : 8643516546 Question Type : MCQ Option Shuffling : Yes Is Question Mandatory : No**

**Correct Marks : 4 Wrong Marks : 1**

ଏକ ତ୍ରିଭୁଜ ABC ରେ, ଯଦି  $|\vec{BC}| = 8$ ,  $|\vec{CA}| = 7$ ,  $|\vec{AB}| = 10$ , ତେବେ  $\vec{AB}$  ଦିଶାଙ୍କର  $\vec{AC}$  ଦିଶାଙ୍କ ଉପରେ ଅଭିଲେଖ (ପ୍ରଲେଖ) ସମାନ :

**Options :**

$$86435119641. \frac{115}{16}$$

$$86435119642. \frac{85}{14}$$

$$86435119643. \frac{127}{20}$$

$$86435119644. \frac{25}{4}$$

**Question Number : 67 Question Id : 8643516547 Question Type : MCQ Option Shuffling : Yes Is Question Mandatory : No**

**Correct Marks : 4 Wrong Marks : 1**

Let the centroid of an equilateral triangle ABC be at the origin. Let one of the sides of the equilateral triangle be along the straight line  $x + y = 3$ . If R and r be the radius of circumcircle and incircle respectively of  $\Delta ABC$ , then  $(R + r)$  is equal to :

**Options :**

86435119645.  $2\sqrt{2}$

86435119646.  $\frac{9}{\sqrt{2}}$

86435119647.  $7\sqrt{2}$

86435119648.  $3\sqrt{2}$

**Question Number : 67 Question Id : 8643516547 Question Type : MCQ Option Shuffling : Yes Is****Question Mandatory : No****Correct Marks : 4 Wrong Marks : 1**

ମାନିନିଅ ସମବାହୁ ତ୍ରିଭୁଜ ABC ର ଭରକେନ୍ଦ୍ର (ମଧ୍ୟମାମାନଙ୍କର ମିଳିତ ବିନ୍ଦୁ) ମୂଳବିନ୍ଦୁ ଉପରେ ଅବସ୍ଥିତ । ସମବାହୁ ତ୍ରିଭୁଜର ଏକ ବାହୁ ସରଳରେଖା  $x+y=3$  ସହ ବରାବର । ଯଦି R ଏବଂ r ଯଥାକ୍ରମେ ତ୍ରିଭୁଜ ABC ର ପରିବୃତ୍ତ ଓ ଅନ୍ତଃବୃତ୍ତର ବ୍ୟାସାର୍ଦ୍ଧ ହୁଅନ୍ତି, ତେବେ  $(R+r)$  ସମାନ :

**Options :**

86435119645.  $2\sqrt{2}$

86435119646.  $\frac{9}{\sqrt{2}}$

86435119647.  $7\sqrt{2}$

86435119648.  $3\sqrt{2}$

**Question Number : 68 Question Id : 8643516548 Question Type : MCQ Option Shuffling : Yes Is****Question Mandatory : No****Correct Marks : 4 Wrong Marks : 1**

Let a tangent be drawn to the ellipse  $\frac{x^2}{27} + y^2 = 1$  at  $(3\sqrt{3}\cos\theta, \sin\theta)$  where  $\theta \in \left(0, \frac{\pi}{2}\right)$ .

Then the value of  $\theta$  such that the sum of intercepts on axes made by this tangent is minimum is equal to :

Options :

86435119649.  $\frac{\pi}{3}$

86435119650.  $\frac{\pi}{6}$

86435119651.  $\frac{\pi}{8}$

86435119652.  $\frac{\pi}{4}$

Question Number : 68 Question Id : 8643516548 Question Type : MCQ Option Shuffling : Yes Is Question Mandatory : No

Correct Marks : 4 Wrong Marks : 1

ମାନିନିଅ ଦୀର୍ଘବୃତ୍ତ (ଇଲିପ୍ସ)  $\frac{x^2}{27} + y^2 = 1$  ପ୍ରତି ବିନ୍ଦୁ  $(3\sqrt{3}\cos\theta, \sin\theta)$ ,  $\theta \in \left(0, \frac{\pi}{2}\right)$  ଠାରେ ଏକ ସ୍ପର୍ଶକ ଅଙ୍କନ

କରାଯାଇଛି । ତେବେ  $\theta$  ର ମାନ ଯାହା ପାଇଁ, ଏହି ସ୍ପର୍ଶକ ଦ୍ୱାରା ଉଭୟ ଅକ୍ଷରେ ଛେଦାଂଶ ମାନଙ୍କର ସମଷ୍ଟି ନିମ୍ନତମ (ସର୍ବନିମ୍ନ) ଅଟେ ତାହା ସମାନ :

Options :

86435119649.  $\frac{\pi}{3}$

86435119650.  $\frac{\pi}{6}$

86435119651.  $\frac{\pi}{8}$

86435119652.  $\frac{\pi}{4}$



**Question Number : 69 Question Id : 8643516549 Question Type : MCQ Option Shuffling : Yes Is Question Mandatory : No Correct Marks : 4 Wrong Marks : 1**

Let  $y = y(x)$  be the solution of the differential equation  $\frac{dy}{dx} = (y + 1) \left( (y + 1)e^{x^{2/2} - x} \right)$ ,

$0 < x < 2.1$ , with  $y(2) = 0$ . Then the value of  $\frac{dy}{dx}$  at  $x = 1$  is equal to :

**Options :**

86435119653.  $\frac{e^{5/2}}{(1 + e^2)^2}$

86435119654.  $-\frac{2e^2}{(1 + e^2)^2}$

86435119655.  $\frac{5e^{1/2}}{(e^2 + 1)^2}$

86435119656.  $\frac{-e^{3/2}}{(e^2 + 1)^2}$

**Question Number : 69 Question Id : 8643516549 Question Type : MCQ Option Shuffling : Yes Is Question Mandatory : No Correct Marks : 4 Wrong Marks : 1**

ମାନିନିଅ ଅବକଳ ସମୀକରଣ  $\frac{dy}{dx} = (y + 1) \left( (y + 1)e^{x^{2/2} - x} \right)$ ,  $0 < x < 2.1$ ,  $y(2) = 0$  ର  $y = y(x)$  ଏକ

ସମୀକରଣ । ତେବେ  $x = 1$  ଠାରେ  $\frac{dy}{dx}$  ର ମୂଲ୍ୟ ସମାନ :

**Options :**

86435119653.  $\frac{e^{5/2}}{(1 + e^2)^2}$

$$-\frac{2e^2}{(1+e^2)^2}$$

86435119654.

$$\frac{5e^{1/2}}{(e^2+1)^2}$$

86435119655.

$$\frac{-e^{3/2}}{(e^2+1)^2}$$

86435119656.

**Question Number : 70 Question Id : 8643516550 Question Type : MCQ Option Shuffling : Yes Is Question Mandatory : No**

**Correct Marks : 4 Wrong Marks : 1**

The area bounded by the curve  $4y^2 = x^2(4-x)(x-2)$  is equal to :

**Options :**

$$\frac{3\pi}{8}$$

86435119657.

$$\frac{\pi}{16}$$

86435119658.

$$\frac{\pi}{8}$$

86435119659.

$$\frac{3\pi}{2}$$

86435119660.

**Question Number : 70 Question Id : 8643516550 Question Type : MCQ Option Shuffling : Yes Is Question Mandatory : No**

**Correct Marks : 4 Wrong Marks : 1**

ବକ୍ର  $4y^2 = x^2(4-x)(x-2)$  ଦ୍ୱାରା ଆବଦ୍ଧ କ୍ଷେତ୍ରର କ୍ଷେତ୍ରଫଳ ସମାନ :

**Options :**

$$\frac{3\pi}{8}$$

86435119657.

$$86435119658. \frac{\pi}{16}$$

$$86435119659. \frac{\pi}{8}$$

$$86435119660. \frac{3\pi}{2}$$

**Question Number : 71 Question Id : 8643516551 Question Type : MCQ Option Shuffling : Yes Is**

**Question Mandatory : No**

**Correct Marks : 4 Wrong Marks : 1**

Let  $g(x) = \int_0^x f(t)dt$ , where  $f$  is continuous function in  $[0, 3]$  such that  $\frac{1}{3} \leq f(t) \leq 1$  for all  $t \in [0, 1]$  and  $0 \leq f(t) \leq \frac{1}{2}$  for all  $t \in (1, 3]$ . The largest possible interval in which  $g(3)$  lies is :

**Options :**

$$86435119661. \left[ \frac{1}{3}, 2 \right]$$

$$86435119662. \left[ -1, -\frac{1}{2} \right]$$

$$86435119663. [1, 3]$$

$$86435119664. \left[ -\frac{3}{2}, -1 \right]$$

**Question Number : 71 Question Id : 8643516551 Question Type : MCQ Option Shuffling : Yes Is**

**Question Mandatory : No**

**Correct Marks : 4 Wrong Marks : 1**

ମାନିନିଅ  $g(x) = \int_0^x f(t)dt$ , ଯେଉଁଠାରେ ଫଳନ  $f$  ଚି  $[0, 3]$  ଅନ୍ତରାଳରେ ଅବିଚ୍ଛିନ୍ନ ଅଟେ ଯେପରିକି  $\frac{1}{3} \leq f(t) \leq 1$ ,

ସମସ୍ତ  $t \in [0, 1]$  ପାଇଁ ଏବଂ  $0 \leq f(t) \leq \frac{1}{2}$  ସମସ୍ତ  $t \in (1, 3]$  ପାଇଁ । ଅଧିକତମ ସମ୍ଭବ ଅନ୍ତରାଳ, ଯେଉଁଥିରେ  $g(3)$  ରହିବ

(ଅବସ୍ଥିତ ହେବ) ଚାହା ଅଟେ :

**Options :**

86435119661.  $\left[\frac{1}{3}, 2\right]$

86435119662.  $\left[-1, -\frac{1}{2}\right]$

86435119663.  $[1, 3]$

86435119664.  $\left[-\frac{3}{2}, -1\right]$

**Question Number : 72 Question Id : 8643516552 Question Type : MCQ Option Shuffling : Yes Is Question Mandatory : No**

**Correct Marks : 4 Wrong Marks : 1**

Let  $f: \mathbb{R} \rightarrow \mathbb{R}$  be a function defined as

$$f(x) = \begin{cases} \frac{\sin(a+1)x + \sin 2x}{2x}, & \text{if } x < 0 \\ b, & \text{if } x = 0 \\ \frac{\sqrt{x+bx^3} - \sqrt{x}}{bx^{5/2}}, & \text{if } x > 0 \end{cases}$$

If  $f$  is continuous at  $x=0$ , then the value of  $a+b$  is equal to :

**Options :**

86435119665.  $-\frac{5}{2}$

86435119666. -3

86435119667. -2

86435119668.  $-\frac{3}{2}$ 

**Question Number : 72 Question Id : 8643516552 Question Type : MCQ Option Shuffling : Yes Is Question Mandatory : No**

**Correct Marks : 4 Wrong Marks : 1**

ମାନନିଅ ଫଳନ  $f: \mathbf{R} \rightarrow \mathbf{R}$  ନିମ୍ନପ୍ରକାରେ ପ୍ରକାଶିତ ।

$$f(x) = \begin{cases} \frac{\sin(a+1)x + \sin 2x}{2x}, & \text{ଯଦି } x < 0 \\ b, & \text{ଯଦି } x = 0 \\ \frac{\sqrt{x + bx^3} - \sqrt{x}}{bx^{5/2}}, & \text{ଯଦି } x > 0 \end{cases}$$

ଯଦି  $x=0$  ଠାରେ ଫଳନ  $f$  ଅବିଚ୍ଛିନ୍ନ ଅଟେ, ତେବେ  $a+b$  ର ମୂଲ୍ୟ ସମାନ :

**Options :**

86435119665.  $-\frac{5}{2}$ 

86435119666. -3

86435119667. -2

86435119668.  $-\frac{3}{2}$ 

**Question Number : 73 Question Id : 8643516553 Question Type : MCQ Option Shuffling : Yes Is Question Mandatory : No**

**Correct Marks : 4 Wrong Marks : 1**

Let  $S_1$  be the sum of first  $2n$  terms of an arithmetic progression. Let  $S_2$  be the sum of first  $4n$  terms of the same arithmetic progression. If  $(S_2 - S_1)$  is 1000, then the sum of the first  $6n$  terms of the arithmetic progression is equal to :

**Options :**

86435119669. 7000

86435119670. 5000

86435119671. 3000

86435119672. 1000

**Question Number : 73 Question Id : 8643516553 Question Type : MCQ Option Shuffling : Yes Is Question Mandatory : No**

**Correct Marks : 4 Wrong Marks : 1**

ମାନିନିଅ ଏକ ସମାନ୍ତର ଶ୍ରେଣୀ (ପ୍ରଗତି) ର ପ୍ରଥମ  $2n$  ପଦ ମାନଙ୍କର ଯୋଗଫଳ  $S_1$  ଏବଂ ଏହି ସମାନ୍ତର ଶ୍ରେଣୀର ପ୍ରଥମ  $4n$  ପଦମାନଙ୍କର ଯୋଗଫଳ  $S_2$  । ଯଦି  $(S_2 - S_1) = 1000$ , ତେବେ ଏହି ସମାନ୍ତର ଶ୍ରେଣୀର ପ୍ରଥମ  $6n$  ପଦମାନଙ୍କର ଯୋଗଫଳ ସମାନ :

**Options :**

86435119669. 7000

86435119670. 5000

86435119671. 3000

86435119672. 1000

**Question Number : 74 Question Id : 8643516554 Question Type : MCQ Option Shuffling : Yes Is Question Mandatory : No**

**Correct Marks : 4 Wrong Marks : 1**

Let  $S_1 : x^2 + y^2 = 9$  and  $S_2 : (x - 2)^2 + y^2 = 1$ . Then the locus of center of a variable circle  $S$  which touches  $S_1$  internally and  $S_2$  externally always passes through the points :

**Options :**

86435119673.  $\left(2, \pm \frac{3}{2}\right)$ 86435119674.  $(0, \pm \sqrt{3})$ 86435119675.  $(1, \pm 2)$



$$\left(\frac{1}{2}, \pm \frac{\sqrt{5}}{2}\right)$$

86435119676.

**Question Number : 74 Question Id : 8643516554 Question Type : MCQ Option Shuffling : Yes Is Question Mandatory : No**

**Correct Marks : 4 Wrong Marks : 1**

ମାନିନିଅ  $S_1 : x^2 + y^2 = 9$  ଏବଂ  $S_2 : (x-2)^2 + y^2 = 1$  । ଡେବେ ଏକ ଚଳବୃତ୍ତ  $S$  ଯାହା ବୃତ୍ତ  $S_1$  ସହ ଅନ୍ତଃସ୍ପର୍ଶକ ଓ ବୃତ୍ତ  $S_2$  ସହ ବହିଃସ୍ପର୍ଶକ କରେ, ତାର କେନ୍ଦ୍ରବିନ୍ଦୁର ସଞ୍ଚାର ପଥ ସର୍ବଦା ଯେଉଁ ବିନ୍ଦୁ ମଧ୍ୟ ଦେଇ ଗତି କରନ୍ତି ସେ ବିନ୍ଦୁଟି :

**Options :**

$$\left(2, \pm \frac{3}{2}\right)$$

86435119673.

$$(0, \pm \sqrt{3})$$

86435119674.

$$(1, \pm 2)$$

86435119675.

$$\left(\frac{1}{2}, \pm \frac{\sqrt{5}}{2}\right)$$

86435119676.

**Question Number : 75 Question Id : 8643516555 Question Type : MCQ Option Shuffling : Yes Is Question Mandatory : No**

**Correct Marks : 4 Wrong Marks : 1**

Let the system of linear equations

$$4x + \lambda y + 2z = 0$$

$$2x - y + z = 0$$

$$\mu x + 2y + 3z = 0, \lambda, \mu \in \mathbb{R}.$$

has a non-trivial solution. Then which of the following is true ?

**Options :**

$$\lambda = 3, \mu \in \mathbb{R}$$

86435119677.

$$\mu = -6, \lambda \in \mathbb{R}$$

86435119678.

86435119679.  $\lambda = 2, \mu \in \mathbb{R}$

86435119680.  $\mu = 6, \lambda \in \mathbb{R}$

**Question Number : 75 Question Id : 8643516555 Question Type : MCQ Option Shuffling : Yes Is Question Mandatory : No**

**Correct Marks : 4 Wrong Marks : 1**

ମାନିନିଅ ସହ ସମୀକରଣ ସମୂହ

$$4x + \lambda y + 2z = 0$$

$$2x - y + z = 0$$

$$\mu x + 2y + 3z = 0, \lambda, \mu \in \mathbb{R} \text{ ର}$$

ଏକ ଅସାଧାରଣ ସମାଧାନ ଅଛି । ତେବେ ନିମ୍ନମଧ୍ୟରୁ କେଉଁଟି ସତ ?

**Options :**

86435119677.  $\lambda = 3, \mu \in \mathbb{R}$

86435119678.  $\mu = -6, \lambda \in \mathbb{R}$

86435119679.  $\lambda = 2, \mu \in \mathbb{R}$

86435119680.  $\mu = 6, \lambda \in \mathbb{R}$

**Question Number : 76 Question Id : 8643516556 Question Type : MCQ Option Shuffling : Yes Is Question Mandatory : No**

**Correct Marks : 4 Wrong Marks : 1**

Let  $f: \mathbb{R} - \{3\} \rightarrow \mathbb{R} - \{1\}$  be defined by  $f(x) = \frac{x - 2}{x - 3}$ .

Let  $g: \mathbb{R} \rightarrow \mathbb{R}$  be given as  $g(x) = 2x - 3$ . Then, the sum of all the values of  $x$  for which

$f^{-1}(x) + g^{-1}(x) = \frac{13}{2}$  is equal to.

**Options :**

86435119681. 2

86435119682. 5

86435119683. 3

86435119684. 7

**Question Number : 76 Question Id : 8643516556 Question Type : MCQ Option Shuffling : Yes Is Question Mandatory : No**

**Correct Marks : 4 Wrong Marks : 1**

ମାନିନିଅ  $f: \mathbb{R} - \{3\} \rightarrow \mathbb{R} - \{1\}$ ,  $f(x) = \frac{x-2}{x-3}$  ।

$g: \mathbb{R} \rightarrow \mathbb{R}$  କୁ  $g(x) = 2x - 3$  ରୂପେ ପ୍ରକାଶ କରାଯାଇଛି । ତେବେ  $x$  ର ସମସ୍ତ ମୂଲ୍ୟମାନଙ୍କର ଯୋଗଫଳ, ଯେଉଁଥି

ପାଇଁ  $f^{-1}(x) + g^{-1}(x) = \frac{13}{2}$  ଚାହା ଅଟେ :

**Options :**

86435119681. 2

86435119682. 5

86435119683. 3

86435119684. 7

**Question Number : 77 Question Id : 8643516557 Question Type : MCQ Option Shuffling : Yes Is Question Mandatory : No**

**Correct Marks : 4 Wrong Marks : 1**

Let a complex number be  $w = 1 - \sqrt{3}i$ . Let another complex number  $z$  be such that  $|zw| = 1$

and  $\arg(z) - \arg(w) = \frac{\pi}{2}$ . Then the area of the triangle with vertices origin,  $z$  and  $w$  is equal

to :

**Options :**

86435119685.  $\frac{1}{2}$ 

86435119686. 2

86435119687.  $\frac{1}{4}$

86435119688. 4

**Question Number : 77 Question Id : 8643516557 Question Type : MCQ Option Shuffling : Yes Is Question Mandatory : No**

**Correct Marks : 4 Wrong Marks : 1**

ମାନନିଅ ଏକ ସମିଶ୍ର ସଂଖ୍ୟା (କମ୍ପ୍ଲେକ୍ସ)  $w = 1 - \sqrt{3}i$  । ଅନ୍ୟ ଏକ ସମିଶ୍ର ସଂଖ୍ୟା  $z$  ଯେପରିକି  $|zw|=1$  ଏବଂ

$\arg(z) - \arg(w) = \frac{\pi}{2}$  । ତେବେ ମୂଲ୍ୟରୁ,  $z$  ଏବଂ  $w$  କୁ ଶୀର୍ଷବିନ୍ଦୁ ନେଇ ଗଠନ କରାଯାଇଥିବା ତ୍ରିଭୁଜର କ୍ଷେତ୍ରଫଳ ସମାନ :

**Options :**

86435119685.  $\frac{1}{2}$

86435119686. 2

86435119687.  $\frac{1}{4}$

86435119688. 4

**Question Number : 78 Question Id : 8643516558 Question Type : MCQ Option Shuffling : Yes Is Question Mandatory : No**

**Correct Marks : 4 Wrong Marks : 1**

Define a relation R over a class of  $n \times n$  real matrices A and B as

“ARB iff there exists a non-singular matrix P such that  $PAP^{-1} = B$ ”.

Then which of the following is true ?

**Options :**

86435119689. R is reflexive, symmetric but not transitive

86435119690. R is reflexive, transitive but not symmetric

86435119691. R is symmetric, transitive but not reflexive,

86435119692. R is an equivalence relation

**Question Number : 78 Question Id : 8643516558 Question Type : MCQ Option Shuffling : Yes Is Question Mandatory : No**

**Correct Marks : 4 Wrong Marks : 1**

$n \times n$  ସମୂହ ବାସ୍ତବିକ ମାଟ୍ରିକ୍ସରୁ A ଏବଂ B ମାଟ୍ରିକ୍ସରେ ଏକ ସମ୍ବନ୍ଧ R କୁ ଏହିପରି ପରିଭାଷିତ କରାଯାଇଛି, “ARB ଯଦି ଏବଂ କେବଳ ଯଦି P ନାମକ ଏକ ମାଟ୍ରିକ୍ସ ଅଛି ଯାହାର ମୂଲ୍ୟ ଶୂନ୍ୟ ନୁହେଁ ଯେପରିକି  $PAP^{-1} = B$ ”, ତେବେ ନିମ୍ନଲିଖିତ କେଉଁଟି ସତ ଅଟେ ?

**Options :**

86435119689. R ସ୍ୱାଭିମୂଖୀ, ସମଞ୍ଜସ କିନ୍ତୁ ସଂକ୍ରମୀ ନୁହେଁ

86435119690. R ସ୍ୱାଭିମୂଖୀ, ସଂକ୍ରମୀ କିନ୍ତୁ ସମଞ୍ଜସ ନୁହେଁ

86435119691. R ସମଞ୍ଜସ, ସଂକ୍ରମୀ କିନ୍ତୁ ସ୍ୱାଭିମୂଖୀ ନୁହେଁ

86435119692. R ଏକ ସମତୁଲ୍ୟ ସମ୍ବନ୍ଧ ଅଟେ

**Question Number : 79 Question Id : 8643516559 Question Type : MCQ Option Shuffling : Yes Is Question Mandatory : No**

**Correct Marks : 4 Wrong Marks : 1**

Consider a hyperbola H :  $x^2 - 2y^2 = 4$ . Let the tangent at a point P  $(4, \sqrt{6})$  meet the x-axis at Q and latus rectum at R  $(x_1, y_1)$ ,  $x_1 > 0$ . If F is a focus of H which is nearer to the point P, then the area of  $\Delta QFR$  is equal to .

**Options :**

86435119693.  $\sqrt{6} - 1$

86435119694.  $\frac{7}{\sqrt{6}} - 2$

86435119695.  $4\sqrt{6} - 1$

86435119696.  $4\sqrt{6}$

**Question Number : 79 Question Id : 8643516559 Question Type : MCQ Option Shuffling : Yes Is Question Mandatory : No**

**Correct Marks : 4 Wrong Marks : 1**

ଏକ ଅତିପରବଳୟ (ହାଇପରବୋଲା)  $H : x^2 - 2y^2 = 4$  କୁ ବିଚାର କର । ମାନିନିଅ ବିନ୍ଦୁ  $P(4, \sqrt{6})$  ଠାରେ ସର୍ତ୍ତକ,  $x$ -ଅକ୍ଷ ସହ  $Q$  ବିନ୍ଦୁରେ ଏବଂ ଲେଟସ୍ ରେକ୍ଟମ୍ (ନାଭିଜ୍ୟା) ସହ  $R(x_1, y_1)$ ,  $x_1 > 0$  ବିନ୍ଦୁରେ ମିଳିତ ହୁଏ । ଯଦି ହାଇପରବୋଲା  $H$  ର ନାଭି (ଫୋକସ୍)  $F$  ଅଟେ ଯାହା  $P$  ବିନ୍ଦୁର ନିକଟବର୍ତ୍ତୀ, ତେବେ ତ୍ରିଭୁଜ  $QFR$  ର କ୍ଷେତ୍ରଫଳ ସମାନ :

**Options :**

86435119693.  $\sqrt{6} - 1$

86435119694.  $\frac{7}{\sqrt{6}} - 2$

86435119695.  $4\sqrt{6} - 1$

86435119696.  $4\sqrt{6}$

**Question Number : 80 Question Id : 8643516560 Question Type : MCQ Option Shuffling : Yes Is Question Mandatory : No**

**Correct Marks : 4 Wrong Marks : 1**

Let  $\vec{a}$  and  $\vec{b}$  be two non-zero vectors perpendicular to each other and  $|\vec{a}| = |\vec{b}|$ . If

$|\vec{a} \times \vec{b}| = |\vec{a}|$ , then the angle between the vectors  $(\vec{a} + \vec{b} + (\vec{a} \times \vec{b}))$  and  $\vec{a}$  is equal to :

**Options :**

86435119697.  $\cos^{-1}\left(\frac{1}{\sqrt{3}}\right)$

86435119698.  $\cos^{-1}\left(\frac{1}{\sqrt{2}}\right)$

86435119699.  $\sin^{-1}\left(\frac{1}{\sqrt{3}}\right)$



$$\sin^{-1}\left(\frac{1}{\sqrt{6}}\right)$$

86435119700.

**Question Number : 80 Question Id : 8643516560 Question Type : MCQ Option Shuffling : Yes Is**

**Question Mandatory : No**

**Correct Marks : 4 Wrong Marks : 1**

ମାନିନିଅ  $\vec{a}$  ଏବଂ  $\vec{b}$  ଦୁଇଟି ଅଣଶୂନ୍ୟ ପରସ୍ପର ପ୍ରତି ଲମ୍ବ ଦିଶାଙ୍କ ଏବଂ  $|\vec{a}| = |\vec{b}|$  । ଯଦି  $|\vec{a} \times \vec{b}| = |\vec{a}|$ , ତେବେ

ଦିଶାଙ୍କ  $(\vec{a} + \vec{b} + (\vec{a} \times \vec{b}))$  ଏବଂ  $\vec{a}$  ମଧ୍ୟରେ ଥିବା କୋଣଟି ସମାନ :

**Options :**

$$\cos^{-1}\left(\frac{1}{\sqrt{3}}\right)$$

86435119697.

$$\cos^{-1}\left(\frac{1}{\sqrt{2}}\right)$$

86435119698.

$$\sin^{-1}\left(\frac{1}{\sqrt{3}}\right)$$

86435119699.

$$\sin^{-1}\left(\frac{1}{\sqrt{6}}\right)$$

86435119700.

## Mathematics Section B

<b>Section Id :</b>	864351438
<b>Section Number :</b>	6
<b>Section type :</b>	Online
<b>Mandatory or Optional :</b>	Mandatory
<b>Number of Questions :</b>	10
<b>Number of Questions to be attempted :</b>	5
<b>Section Marks :</b>	20
<b>Mark As Answered Required? :</b>	Yes
<b>Sub-Section Number :</b>	1
<b>Sub-Section Id :</b>	864351438

Question Shuffling Allowed :

Yes

Question Number : 81 Question Id : 8643516561 Question Type : SA

Correct Marks : 4 Wrong Marks : 0

If  $f(x)$  and  $g(x)$  are two polynomials such that the polynomial  $P(x) = f(x^3) + x g(x^3)$  is divisible by  $x^2 + x + 1$ , then  $P(1)$  is equal to \_\_\_\_\_.

Response Type : Numeric

Evaluation Required For SA : Yes

Show Word Count : Yes

Answers Type : Equal

Text Areas : PlainText

Possible Answers :

100

Question Number : 81 Question Id : 8643516561 Question Type : SA

Correct Marks : 4 Wrong Marks : 0

ଯଦି  $f(x)$  ଏବଂ  $g(x)$  ଦୁଇଟି ବହୁପଦ ରାଶି ହୁଅନ୍ତି ଯେପରିକି  $P(x) = f(x^3) + x g(x^3)$  ବହୁପଦଟି  $x^2 + x + 1$  ଦ୍ୱାରା ବିଭାଜ୍ୟ, ତେବେ  $P(1)$  ସମାନ \_\_\_\_\_ ।

Response Type : Numeric

Evaluation Required For SA : Yes

Show Word Count : Yes

Answers Type : Equal

Text Areas : PlainText

Possible Answers :

100

Question Number : 82 Question Id : 8643516562 Question Type : SA

Correct Marks : 4 Wrong Marks : 0

Let  $I$  be an identity matrix of order  $2 \times 2$  and  $P = \begin{bmatrix} 2 & -1 \\ 5 & -3 \end{bmatrix}$ . Then the value of  $n \in \mathbb{N}$  for which

$P^n = 5I - 8P$  is equal to \_\_\_\_\_.

Response Type : Numeric

Evaluation Required For SA : Yes

Show Word Count : Yes

Answers Type : Equal

Text Areas : PlainText

Possible Answers :

100

Question Number : 82 Question Id : 8643516562 Question Type : SA

Correct Marks : 4 Wrong Marks : 0

ମାଟ୍ରିକ୍ସ I ଏକ  $(2 \times 2)$  ଅର୍ଡର ବିଶିଷ୍ଟ ଅଭେଦ ମାଟ୍ରିକ୍ସ ଏବଂ  $P = \begin{bmatrix} 2 & -1 \\ 5 & -3 \end{bmatrix}$  । ତେବେ n ର ମୂଲ୍ୟ ( $n \in \mathbb{N}$ ) ଯାହାପାଇଁ

$P^n = 5I - 8P$ , ତାହା ସମାନ \_\_\_\_\_ ।

Response Type : Numeric

Evaluation Required For SA : Yes

Show Word Count : Yes

Answers Type : Equal

Text Areas : PlainText

Possible Answers :

100

Question Number : 83 Question Id : 8643516563 Question Type : SA

Correct Marks : 4 Wrong Marks : 0

The term independent of  $x$  in the expansion of  $\left[ \frac{x+1}{x^{2/3} - x^{1/3} + 1} - \frac{x-1}{x - x^{1/2}} \right]^{10}$ ,  $x \neq 1$ , is equal

to \_\_\_\_\_.

Response Type : Numeric

Evaluation Required For SA : Yes

Show Word Count : Yes

Answers Type : Equal

Text Areas : PlainText

Possible Answers :

100

Question Number : 83 Question Id : 8643516563 Question Type : SA

Correct Marks : 4 Wrong Marks : 0

$\left[ \frac{x+1}{x^{2/3} - x^{1/3} + 1} - \frac{x-1}{x - x^{1/2}} \right]^{10}$ , ( $x \neq 1$ ) ର ପ୍ରସାରଣରେ  $x$  ନଥିବା ପଦଟି ସମାନ \_\_\_\_\_ ।

Response Type : Numeric

Evaluation Required For SA : Yes

Show Word Count : Yes

Answers Type : Equal

Text Areas : PlainText

Possible Answers :

100

**Question Number : 84 Question Id : 8643516564 Question Type : SA**

**Correct Marks : 4 Wrong Marks : 0**

If  $\sum_{r=1}^{10} r! (r^3 + 6r^2 + 2r + 5) = \alpha (11!),$

then the value of  $\alpha$  is equal to \_\_\_\_\_.

**Response Type : Numeric**

**Evaluation Required For SA : Yes**

**Show Word Count : Yes**

**Answers Type : Equal**

**Text Areas : PlainText**

**Possible Answers :**

100

**Question Number : 84 Question Id : 8643516564 Question Type : SA**

**Correct Marks : 4 Wrong Marks : 0**

ଯଦି  $\sum_{r=1}^{10} r! (r^3 + 6r^2 + 2r + 5) = \alpha (11!)$  ହୁଏ, ତେବେ  $\alpha$  ର ମୂଲ୍ୟ ସମାନ \_\_\_\_\_ ।

**Response Type : Numeric**

**Evaluation Required For SA : Yes**

**Show Word Count : Yes**

**Answers Type : Equal**

**Text Areas : PlainText**

**Possible Answers :**

100

**Question Number : 85 Question Id : 8643516565 Question Type : SA**

**Correct Marks : 4 Wrong Marks : 0**

Let  $P(x)$  be a real polynomial of degree 3 which vanishes at  $x = -3$ . Let  $P(x)$  have local

minima at  $x = 1$ , local maxima at  $x = -1$  and  $\int_{-1}^1 P(x) dx = 18$ , then the sum of all the coefficients

of the polynomial  $P(x)$  is equal to \_\_\_\_\_.

**Response Type : Numeric**

**Evaluation Required For SA : Yes**

**Show Word Count : Yes**

**Answers Type : Equal**

**Text Areas : PlainText**

**Possible Answers :**

100

**Question Number : 85 Question Id : 8643516565 Question Type : SA**

**Correct Marks : 4 Wrong Marks : 0**

ମାନିନିଅ 3 ଘାତସୂତ୍ରୀ ଏକ ବାସ୍ତବିକ ବହୁପଦ  $P(x)$  ଯାହାର ମୂଲ୍ୟ  $x = -3$  ଠାରେ ଶୂନ୍ୟ ହୋଇଯାଏ ।  $P(x)$  ର ସ୍ଥାନୀୟ

ନ୍ୟୁନତମ (ସର୍ବନିମ୍ନ)  $x = 1$  ଠାରେ, ସ୍ଥାନୀୟ ଅଧିକତମ (ସର୍ବାଧିକ)  $x = -1$  ଠାରେ ଏବଂ  $\int_{-1}^1 P(x) dx = 18$ , ହୁଏ ତେବେ

ବହୁପଦ  $P(x)$  ର ସମସ୍ତ ସହଗ ମାନକର ଯୋଗଫଳ ସମାନ \_\_\_\_\_ ।

**Response Type : Numeric**

**Evaluation Required For SA : Yes**

**Show Word Count : Yes**

**Answers Type : Equal**

**Text Areas : PlainText**

**Possible Answers :**

100

**Question Number : 86 Question Id : 8643516566 Question Type : SA**

**Correct Marks : 4 Wrong Marks : 0**

Let  $y = y(x)$  be the solution of the differential equation  $x dy - y dx = \sqrt{x^2 - y^2} dx$ ,  $x \geq 1$ , with  $y(1) = 0$ . If the area bounded by the line  $x = 1$ ,  $x = e^\pi$ ,  $y = 0$  and  $y = y(x)$  is  $\alpha e^{2\pi} + \beta$ , then the value of  $10(\alpha + \beta)$  is equal to \_\_\_\_\_.

**Response Type : Numeric**

**Evaluation Required For SA : Yes**

**Show Word Count : Yes**

**Answers Type : Equal**

**Text Areas : PlainText**

**Possible Answers :**

100

**Question Number : 86 Question Id : 8643516566 Question Type : SA**

**Correct Marks : 4 Wrong Marks : 0**

ମାନିନିଅ ଅବକଳ ସମୀକରଣ  $x dy - y dx = \sqrt{x^2 - y^2} dx$ ,  $x \geq 1$  ର  $y = y(x)$  ଏକ ସମାଧାନ ଯେଉଁଠାରେ  $y(1) = 0$  । ଯଦି ରେଖା  $x = 1$ ,  $x = e^\pi$ ,  $y = 0$  ଏବଂ  $y = y(x)$  ମାନକ ଦ୍ୱାରା ଆବଦ୍ଧ କ୍ଷେତ୍ରର କ୍ଷେତ୍ରଫଳ  $\alpha e^{2\pi} + \beta$  ହୁଏ, ତେବେ  $10(\alpha + \beta)$  ର ମୂଲ୍ୟ ସମାନ \_\_\_\_\_ ।

**Response Type : Numeric**

**Evaluation Required For SA : Yes**

**Show Word Count : Yes**

**Answers Type :** Equal

**Text Areas :** PlainText

**Possible Answers :**

100

**Question Number : 87 Question Id : 8643516567 Question Type : SA**

**Correct Marks : 4 Wrong Marks : 0**

Let P be a plane containing the line  $\frac{x-1}{3} = \frac{y+6}{4} = \frac{z+5}{2}$  and parallel to the line

$\frac{x-3}{4} = \frac{y-2}{-3} = \frac{z+5}{7}$ . If the point  $(1, -1, \alpha)$  lies on the plane P, then the value of  $|5\alpha|$  is equal to \_\_\_\_\_.

**Response Type :** Numeric

**Evaluation Required For SA :** Yes

**Show Word Count :** Yes

**Answers Type :** Equal

**Text Areas :** PlainText

**Possible Answers :**

100

**Question Number : 87 Question Id : 8643516567 Question Type : SA**

**Correct Marks : 4 Wrong Marks : 0**

ମାନିନିଅ P ଏକ ସମତଳ ଅଟେ ଯାହା ଉପରେ ରେଖା  $\frac{x-1}{3} = \frac{y+6}{4} = \frac{z+5}{2}$  ଅବସ୍ଥିତ ଏବଂ ଏହି ସମତଳ ରେଖା

$\frac{x-3}{4} = \frac{y-2}{-3} = \frac{z+5}{7}$  ସହ ସମାନ୍ତର । ଯଦି ବିନ୍ଦୁ  $(1, -1, \alpha)$ , P ସମତଳ ଉପରେ ଅବସ୍ଥିତ ହୁଏ, ତେବେ  $|5\alpha|$  ର

ମୂଲ୍ୟ ସମାନ \_\_\_\_\_ ।

**Response Type :** Numeric

**Evaluation Required For SA :** Yes

**Show Word Count :** Yes

**Answers Type :** Equal

**Text Areas :** PlainText

**Possible Answers :**

100

**Question Number : 88 Question Id : 8643516568 Question Type : SA**

**Correct Marks : 4 Wrong Marks : 0**



Let the mirror image of the point  $(1, 3, a)$  with respect to the plane  $\vec{r} \cdot (2\hat{i} - \hat{j} + \hat{k}) - b = 0$  be  $(-3, 5, 2)$ . Then, the value of  $|a + b|$  is equal to \_\_\_\_\_.

**Response Type :** Numeric

**Evaluation Required For SA :** Yes

**Show Word Count :** Yes

**Answers Type :** Equal

**Text Areas :** PlainText

**Possible Answers :**

100

**Question Number :** 88 **Question Id :** 8643516568 **Question Type :** SA

**Correct Marks :** 4 **Wrong Marks :** 0

ମାନିନିଅ ସମତଳ  $\vec{r} \cdot (2\hat{i} - \hat{j} + \hat{k}) - b = 0$  ସହ ସାପେକ୍ଷ ବିନ୍ଦୁ  $(1, 3, a)$  ର ଦର୍ପଣ ପ୍ରତିବିମ୍ବ  $(-3, 5, 2)$  । ତେବେ

$|a + b|$  ର ମୂଲ୍ୟ ସମାନ \_\_\_\_\_ ।

**Response Type :** Numeric

**Evaluation Required For SA :** Yes

**Show Word Count :** Yes

**Answers Type :** Equal

**Text Areas :** PlainText

**Possible Answers :**

100

**Question Number :** 89 **Question Id :** 8643516569 **Question Type :** SA

**Correct Marks :** 4 **Wrong Marks :** 0

Let  ${}^nC_r$  denote the binomial coefficient of  $x^r$  in the expansion of  $(1+x)^n$ .

If  $\sum_{k=0}^{10} (2^2 + 3k) {}^nC_k = \alpha \cdot 3^{10} + \beta \cdot 2^{10}$ ,  $\alpha, \beta \in \mathbb{R}$ , then  $\alpha + \beta$  is equal to \_\_\_\_\_.

**Response Type :** Numeric

**Evaluation Required For SA :** Yes

**Show Word Count :** Yes

**Answers Type :** Equal

**Text Areas :** PlainText

**Possible Answers :**

100

**Question Number :** 89 **Question Id :** 8643516569 **Question Type :** SA

**Correct Marks :** 4 **Wrong Marks :** 0

ମାନିନିଅ  $(1+x)^n$  ର ପ୍ରସାରଣରେ  $x^r$  ର ଦ୍ଵିପଦ ସହଗ  ${}^nC_r$  । ଯଦି  $\sum_{k=0}^{10} (2^2 + 3k) {}^nC_k = \alpha.3^{10} + \beta.2^{10}$ ,  $\alpha,$

$\beta \in \mathbb{R}$ , ତେବେ  $\alpha + \beta$  ସମାନ \_\_\_\_\_ ।

**Response Type :** Numeric

**Evaluation Required For SA :** Yes

**Show Word Count :** Yes

**Answers Type :** Equal

**Text Areas :** PlainText

**Possible Answers :**

100

**Question Number :** 90 **Question Id :** 8643516570 **Question Type :** SA

**Correct Marks :** 4 **Wrong Marks :** 0

Let  $f: \mathbb{R} \rightarrow \mathbb{R}$  satisfy the equation  $f(x+y) = f(x).f(y)$  for all  $x, y \in \mathbb{R}$  and  $f(x) \neq 0$  for any  $x \in \mathbb{R}$ .

If the function  $f$  is differentiable at  $x=0$  and  $f'(0)=3$ , then  $\lim_{h \rightarrow 0} \frac{1}{h} (f(h) - 1)$  is equal to

\_\_\_\_\_.

**Response Type :** Numeric

**Evaluation Required For SA :** Yes

**Show Word Count :** Yes

**Answers Type :** Equal

**Text Areas :** PlainText

**Possible Answers :**

100

**Question Number :** 90 **Question Id :** 8643516570 **Question Type :** SA

**Correct Marks :** 4 **Wrong Marks :** 0

ମାନିନିଅ  $f: \mathbb{R} \rightarrow \mathbb{R}$ , ସମୀକରଣ  $f(x+y) = f(x).f(y)$  ସମସ୍ତ  $x, y \in \mathbb{R}$  ଏବଂ  $f(x) \neq 0$  (ଯେକୌଣସି  $x \in \mathbb{R}$  ପାଇଁ) ।

ଯଦି ଫଳନ  $f$ , ବିନ୍ଦୁ  $x=0$  ଠାରେ ଅବକଳନୀୟ ହୁଏ ଏବଂ  $f'(0)=3$ , ତେବେ  $\lim_{h \rightarrow 0} \frac{1}{h} (f(h) - 1)$  ସମାନ

\_\_\_\_\_ ।

**Response Type :** Numeric

**Evaluation Required For SA :** Yes

**Show Word Count :** Yes

**Answers Type :** Equal

**Text Areas :** PlainText

**Possible Answers :**

100

