

nta

Question Paper Name :	B Tech 20072021 Shift 2
Subject Name :	B TECH
Creation Date :	2021-07-25 17:28:53
Duration :	180
Total Marks :	300
Display Marks:	Yes

B TECH

Group Number :	1
Group Id :	864351235
Group Maximum Duration :	0
Group Minimum Duration :	180
Show Attended Group? :	No
Edit Attended Group? :	No
Break time :	0
Group Marks :	300
Is this Group for Examiner? :	No

Physics Section A

Section Id :	864351848
Section Number :	1
Section type :	Online
Mandatory or Optional :	Mandatory

Number of Questions :	20
Number of Questions to be attempted :	20
Section Marks :	80
Enable Mark as Answered Mark for Review and Clear Response :	Yes
Sub-Section Number :	1
Sub-Section Id :	8643511075
Question Shuffling Allowed :	Yes

Question Type : MCQ Is Question Mandatory : No

Correct Marks : 4 Wrong Marks : 1

A simple pendulum of mass ' m ', length ' l ' and charge ' $+q$ ' suspended in the electric field produced by two conducting parallel plates as shown. The value of deflection of pendulum in equilibrium position will be :

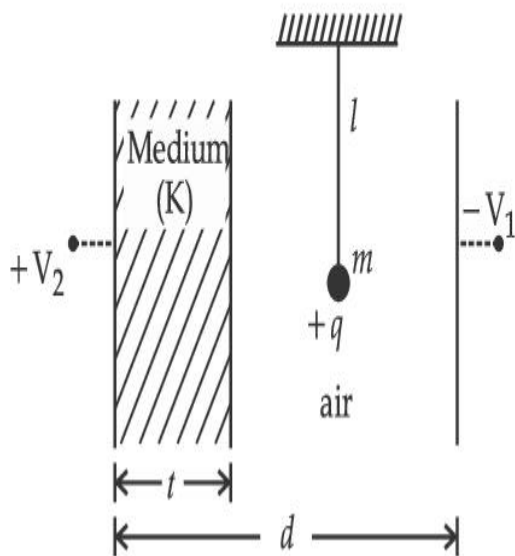

Options :

1. $\tan^{-1} \left[\frac{q}{mg} \times \frac{C_1(V_1 + V_2)}{(C_1 + C_2)(d - t)} \right]$

2. $\tan^{-1} \left[\frac{q}{mg} \times \frac{C_2(V_1 + V_2)}{(C_1 + C_2)(d - t)} \right]$

3.
$$\tan^{-1} \left[\frac{q}{mg} \times \frac{C_1(V_2 - V_1)}{(C_1 + C_2)(d - t)} \right]$$

4.
$$\tan^{-1} \left[\frac{q}{mg} \times \frac{C_2(V_2 - V_1)}{(C_1 + C_2)(d - t)} \right]$$

Question Type : MCQ Is Question Mandatory : No

Correct Marks : 4 Wrong Marks : 1

ଦର୍ଶାଯାଇଥିବା ଅନୁସାରେ, ଦୁଇଟି ସମାନ୍ତର ସୁପରିବାହୀ ପ୍ଲେଟ୍ ଦ୍ୱାରା ସୃଷ୍ଟି ହେଉଥିବା ବିଦ୍ୟୁତ୍ କ୍ଷେତ୍ରରେ 'm' ବସ୍ତୁତ୍ୱ, 'l' ଦୈର୍ଘ୍ୟ ଏବଂ '+q' ଚାର୍ଜ ବିଶିଷ୍ଟ ଏକ ସରଳ ପେଣ୍ଡୁଲମ୍‌କୁ ଝୁଲାଇଯାଇଛି । ସନ୍ତୁଳନ ଅବସ୍ଥାରେ ପେଣ୍ଡୁଲମ୍‌ଟିର ବିକ୍ଷେପର ମାନ ହେବ _____ ।

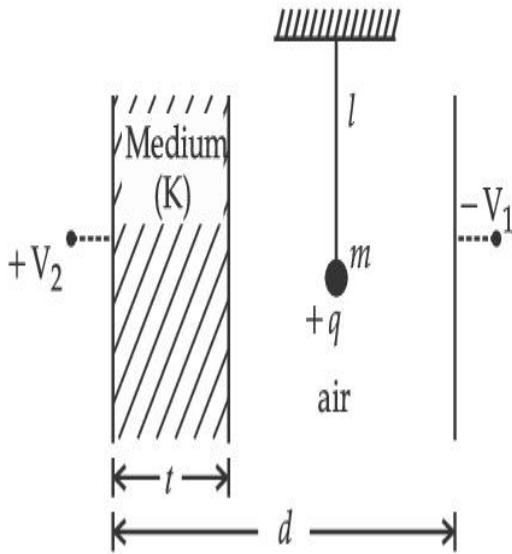

Options :

1.
$$\tan^{-1} \left[\frac{q}{mg} \times \frac{C_1(V_1 + V_2)}{(C_1 + C_2)(d - t)} \right]$$

2.
$$\tan^{-1} \left[\frac{q}{mg} \times \frac{C_2(V_1 + V_2)}{(C_1 + C_2)(d - t)} \right]$$

3.
$$\tan^{-1} \left[\frac{q}{mg} \times \frac{C_1(V_2 - V_1)}{(C_1 + C_2)(d - t)} \right]$$

4.
$$\tan^{-1} \left[\frac{q}{mg} \times \frac{C_2(V_2 - V_1)}{(C_1 + C_2)(d - t)} \right]$$

Question Type : MCQ Is Question Mandatory : No

Correct Marks : 4 Wrong Marks : 1

Find the truth table for the function Y of A and B represented in the following figure.

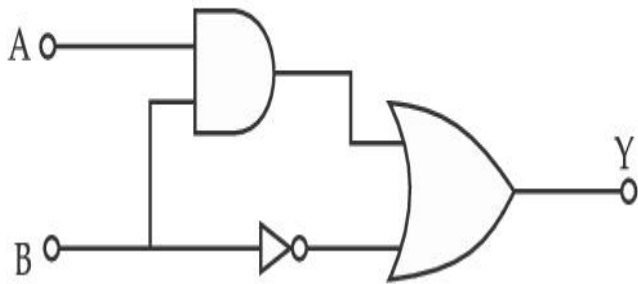

Options :

A	B	Y
0	0	0
0	1	1
1	0	0
1	1	0

1.

2.

A	B	Y
0	0	1
0	1	0
1	0	1
1	1	1

3.

A	B	Y
0	0	0
0	1	1
1	0	1
1	1	1

4.

A	B	Y
0	0	0
0	1	0
1	0	0
1	1	1

Question Type : MCQ Is Question Mandatory : No

Correct Marks : 4 Wrong Marks : 1

ନିମ୍ନରେ ଦର୍ଶାଯାଇଥିବା ଚିତ୍ରରେ A ଓ B ର ଫଳନ Y ପାଇଁ ସତ୍ୟମାନ ସାରଣୀ (ଟ୍ରୁଥ ଟେବୁଲ୍) ବାହାର କର ।

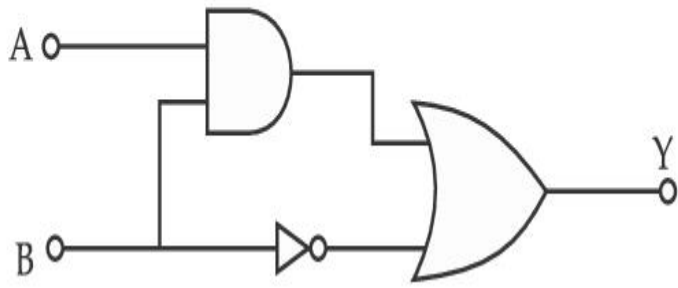

Options :

A	B	Y
0	0	0
0	1	1
1	0	0
1	1	0

1.

A	B	Y
0	0	1
0	1	0
1	0	1
1	1	1

2.

A	B	Y
0	0	0
0	1	1
1	0	1
1	1	1

3.

4.

A	B	Y
0	0	0
0	1	0
1	0	0
1	1	1

Question Type : MCQ Is Question Mandatory : No

Correct Marks : 4 Wrong Marks : 1

A particle of mass M originally at rest is subjected to a force whose direction is constant but magnitude varies with time according to the relation

$$F = F_0 \left[1 - \left(\frac{t - T}{T} \right)^2 \right]$$

Where F_0 and T are constants. The force acts only for the time interval $2T$. The velocity v of the particle after time $2T$ is :

Options :

1. $F_0 T / 3M$
2. $4F_0 T / 3M$
3. $F_0 T / 2M$
4. $2F_0 T / M$

Question Type : MCQ Is Question Mandatory : No

Correct Marks : 4 Wrong Marks : 1

ମୂଳରୁ ଛିର ଭାବରେ ଥିବା M ବସ୍ତୁରୁ ଏକ କଣିକା ଉପରେ ଏକ ବଳ ପ୍ରୟୋଗ କରାଗଲା ଯାହାର ଦିଗ ଛିର ଅଟେ କିନ୍ତୁ ପରିମାଣ

$$\text{ସମୟ ସହ } F = F_0 \left[1 - \left(\frac{t - T}{T} \right)^2 \right] \text{ ସମ୍ପର୍କ ଅନୁସାରେ ବଦଳୁଛି, ଯେଉଁଠାରେ } F_0 \text{ ଏବଂ } T \text{ ବୃତ୍ତାନ୍ତ ସ୍ଥିର । ବଳଟି}$$

କେବଳ $2T$ ସମୟାନ୍ତର ପାଇଁ କାର୍ଯ୍ୟ କରୁଛି । $2T$ ସମୟ ପରେ କଣିକାଟିର ପରିବେଗ v ହେଉଛି :

Options :

1. $F_0 T / 3M$
2. $4F_0 T / 3M$
3. $F_0 T / 2M$
4. $2F_0 T / M$

Question Type : MCQ Is Question Mandatory : No

Correct Marks : 4 Wrong Marks : 1

Match List I with List II.

List I

- (a) Capacitance, C
- (b) Permittivity of free space, ϵ_0
- (c) Permeability of free space, μ_0
- (d) Electric field, E

List II

- (i) $M^1 L^1 T^{-3} A^{-1}$
- (ii) $M^{-1} L^{-3} T^4 A^2$
- (iii) $M^{-1} L^{-2} T^4 A^2$
- (iv) $M^1 L^1 T^{-2} A^{-2}$

Choose the correct answer from the options given below :

Options :

1. (a) \rightarrow (iii), (b) \rightarrow (iv), (c) \rightarrow (ii), (d) \rightarrow (i)
2. (a) \rightarrow (iv), (b) \rightarrow (ii), (c) \rightarrow (iii), (d) \rightarrow (i)
- 3.

(a) → (iii), (b) → (ii), (c) → (iv), (d) → (i)

4. (a) → (iv), (b) → (iii), (c) → (ii), (d) → (i)

Question Type : MCQ Is Question Mandatory : No

Correct Marks : 4 Wrong Marks : 1

ତାଲିକା I ସହ ତାଲିକା II କୁ ମିଳାଅ ।

ତାଲିକା I

ତାଲିକା II

(a) ଧାର୍ମିତା, C

(i) $M^1 L^1 T^{-3} A^{-1}$

(b) ଶୂନ୍ୟର ପରାବୈଦ୍ୟୁତାଙ୍କ, ϵ_0

(ii) $M^{-1} L^{-3} T^4 A^2$

(c) ଶୂନ୍ୟର ପାରଗମ୍ୟତା, μ_0

(iii) $M^{-1} L^{-2} T^4 A^2$

(d) ବିଦ୍ୟୁତ୍ କ୍ଷେତ୍ର, E

(iv) $M^1 L^1 T^{-2} A^{-2}$

ତଳେ ଦିଆଯାଇଥିବା ବିକଳ୍ପ ଗୁଡ଼ିକରୁ ଠିକ୍ ଉତ୍ତରଟି ଚୟନ କର ।

Options :

1. (a) → (iii), (b) → (iv), (c) → (ii), (d) → (i)

2. (a) → (iv), (b) → (ii), (c) → (iii), (d) → (i)

3. (a) → (iii), (b) → (ii), (c) → (iv), (d) → (i)

4. (a) → (iv), (b) → (iii), (c) → (ii), (d) → (i)

Question Type : MCQ Is Question Mandatory : No

Correct Marks : 4 Wrong Marks : 1

One mole of an ideal gas is taken through an adiabatic process where the temperature rises from 27°C to 37°C. If the ideal gas is composed of polyatomic molecule that has 4 vibrational modes, which of the following is true ?

$$[R = 8.314 \text{ J mol}^{-1} \text{ K}^{-1}]$$

Options :

1. work done by the gas is close to 582 J
2. work done on the gas is close to 582 J
3. work done by the gas is close to 332 J
4. work done on the gas is close to 332 J

Question Type : MCQ Is Question Mandatory : No

Correct Marks : 4 Wrong Marks : 1

ଏକ ମୋଲର ଆଦର୍ଶ ଗ୍ୟାସକୁ ରୁଦ୍ଧତାପ ପଦ୍ଧତି ମଧ୍ୟରେ ନିଆଗଲା ଯେଉଁଠାରେ ତାପମାତ୍ରା 27°C ରୁ 37°C କୁ ବୃଦ୍ଧି ହେଲା । ଯଦି ଆଦର୍ଶ ଗ୍ୟାସଟି ବହୁ ପରମାଣୁ ବିଶିଷ୍ଟ ଅଣୁରେ ଗଠିତ ଯାହାର କି 4ଟି କମ୍ପନ ମୋଡ ରହିଅଛି, ତେବେ ନିମ୍ନଲିଖିତ ଉକ୍ତି ମଧ୍ୟରୁ କେଉଁଟି ସତ୍ୟ ? ($R = 8.314 \text{ J ମୋଲ}^{-1} \text{ K}^{-1}$)

Options :

1. ଗ୍ୟାସଟି ଦ୍ୱାରା ସମ୍ପାଦିତ କାର୍ଯ୍ୟର ପରିମାଣ ପାଖାପାଖି 582 J
2. ଗ୍ୟାସଟି ଉପରେ ହେଉଥିବା କାର୍ଯ୍ୟର ପରିମାଣ ପାଖାପାଖି 582 J
3. ଗ୍ୟାସଟି ଦ୍ୱାରା ସମ୍ପାଦିତ କାର୍ଯ୍ୟର ପରିମାଣ ପାଖାପାଖି 332 J
4. ଗ୍ୟାସଟି ଉପରେ ହେଉଥିବା କାର୍ଯ୍ୟର ପରିମାଣ ପାଖାପାଖି 332 J

Question Type : MCQ Is Question Mandatory : No

Correct Marks : 4 Wrong Marks : 1

Given below is the plot of a potential energy function $U(x)$ for a system, in which a particle is in one dimensional motion, while a conservative force $F(x)$ acts on it. Suppose that $E_{\text{mech}} = 8 \text{ J}$, the incorrect statement for this system is :

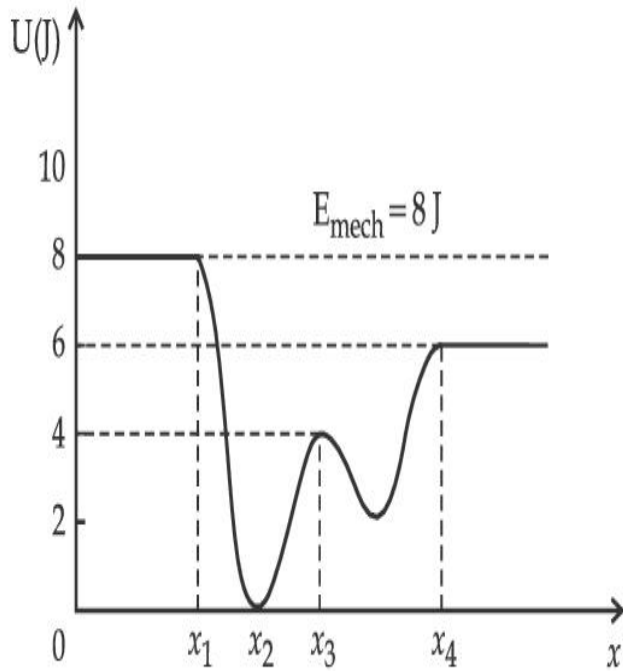

[where K.E. = kinetic energy]

Options :

1. at $x = x_2$, K.E. is greatest and the particle is moving at the fastest speed.
2. at $x < x_1$, K.E. is smallest and the particle is moving at the slowest speed.
3. at $x > x_4$, K.E. is constant throughout the region.
4. at $x = x_3$, K.E. = 4 J.

Question Type : MCQ Is Question Mandatory : No

Correct Marks : 4 Wrong Marks : 1

ଗୋଟିଏ ବ୍ୟବସ୍ଥା (ସିଷ୍ଟମ) ପାଇଁ ଗତିଜ ଶକ୍ତିର ଫଳନ $U(x)$ କୁ ନିମ୍ନରେ ଲେଖାଯାଇଛି । ଯେଉଁଠି କଣିକାଟି ଏକ ବିମିତାୟ ଗତିରେ ରହିଥାଏ ଏବଂ ଏକ ସଂରକ୍ଷିତ ବଳ $F(x)$ ଏହା ଉପରେ କାର୍ଯ୍ୟ କରୁଅଛି । ଧରାଯାଉ $E_{\text{ଯାନ୍ତ୍ରିକ}} = 8 \text{ J}$, ଏହି ବ୍ୟବସ୍ଥାଟି ପାଇଁ କେଉଁ ଉକ୍ତିଟି ଭୁଲ ?

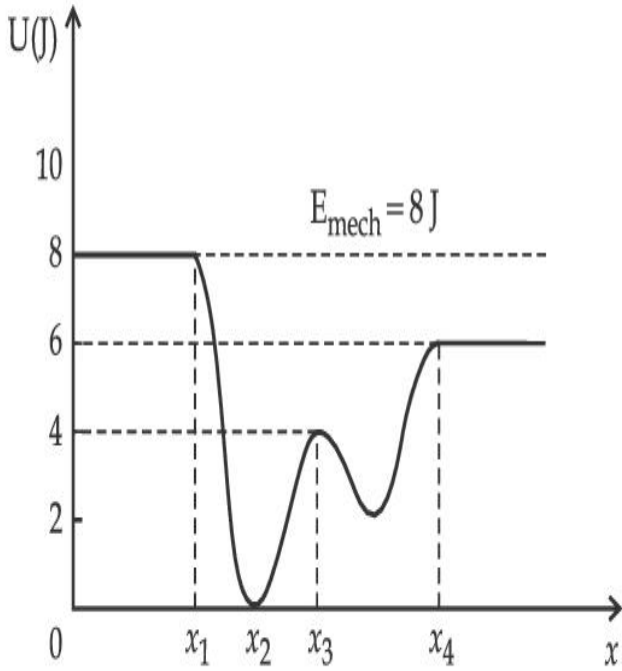

[ଯେଉଁଠି K.E. = ଗତିଜ ଶକ୍ତି]

Options :

1. $x = x_2$ ଠାରେ, ଗତିଜ ଶକ୍ତି ସର୍ବାଧିକ ଏବଂ କଣିକାଟି ସର୍ବାଧିକ ବେଗରେ ଗତି କରୁଅଛି ।
2. $x < x_1$ ପାଇଁ, ଗତିଜ ଶକ୍ତି ସର୍ବନିମ୍ନ ଏବଂ କଣିକାଟି ସବୁଠାରୁ ଧିର ବେଗରେ ଗତି କରୁଅଛି ।
3. $x > x_4$ ପାଇଁ ଗତିଜ ଶକ୍ତି ସବୁ କ୍ଷେତ୍ରରେ ସ୍ଥିର ରହୁଛି ।
4. $x = x_3$ ଠାରେ, ଗତିଜ ଶକ୍ତି = 4 J

Question Type : MCQ Is Question Mandatory : No

Correct Marks : 4 Wrong Marks : 1

Consider the following statements :

- A. Atoms of each element emit characteristics spectrum.
- B. According to Bohr's Postulate, an electron in a hydrogen atom, revolves in a certain stationary orbit.
- C. The density of nuclear matter depends on the size of the nucleus.
- D. A free neutron is stable but a free proton decay is possible.
- E. Radioactivity is an indication of the instability of nuclei.

Choose the correct answer from the options given below :

Options :

- 1. A, B and E only
- 2. A, C and E only
- 3. B and D only
- 4. A, B, C, D and E

Question Type : MCQ Is Question Mandatory : No

Correct Marks : 4 Wrong Marks : 1

ସଠିକ୍ ବିକଳ୍ପ ଗୁଡ଼ିକୁ ଚିହ୍ନଟ କର :

- (A) ପ୍ରତ୍ୟେକ ମୌଳିକ ପଦାର୍ଥର ପରମାଣୁ ଗୁଡ଼ିକ ସ୍ଥାୟୀ ଅଟନ୍ତି ଏବଂ ସ୍ୱଭାବସିଦ୍ଧ ବର୍ଣ୍ଣାଳୀ (କ୍ୟାରେକ୍ଟରଷ୍ଟିକ୍ ସ୍ପେକ୍ଟ୍ରମ୍) ନିଃସୃତ କରନ୍ତି ।
- (B) ବୋହରଙ୍କ ସ୍ୱୀକାର ଅନୁସାରେ, ଗୋଟିଏ ଇଲେକ୍ଟ୍ରନ୍ ଏକ ନିର୍ଦ୍ଦିଷ୍ଟ ଅପରିବର୍ତ୍ତିତ କକ୍ଷପଥରେ ଘୂରୁଥାନ୍ତି ।
- (C) ନ୍ୟୁକ୍ଲୀୟ ବସ୍ତୁର ସାନ୍ଦ୍ରତା ନ୍ୟୁକ୍ଲିୟସ୍ ଆୟତନ ଉପରେ ନିର୍ଭର କରେ ।
- (D) ମୁକ୍ତ ନ୍ୟୁଟ୍ରନ୍ ସ୍ଥାୟୀ ଅଟନ୍ତି କିନ୍ତୁ ମୁକ୍ତ ପ୍ରୋଟନ୍‌ର କ୍ଷୟ ସମ୍ଭବ ।
- (E) ତେଜସ୍ୱିୟତା ନ୍ୟୁକ୍ଲୀୟସ୍ ଗୁଡ଼ିକର ଅସ୍ଥିରତାକୁ ସୂଚାଇଥାଏ ।

ନିମ୍ନୋକ୍ତ ବିକଳ୍ପଗୁଡ଼ିକ ମଧ୍ୟରୁ ଠିକ୍ ଉତ୍ତରଟି ବାଛି :

Options :

1. କେବଳ A, B ଏବଂ E
2. କେବଳ A, C ଏବଂ E
3. କେବଳ B ଓ D
4. A, B, C, D ଏବଂ E

Question Type : MCQ Is Question Mandatory : No

Correct Marks : 4 Wrong Marks : 1

A raindrop with radius $R=0.2$ mm falls from a cloud at a height $h=2000$ m above the ground. Assume that the drop is spherical throughout its fall and the force of buoyancy may be neglected, then the terminal speed attained by the raindrop is :

[Density of water $f_w=1000$ kg m⁻³

and Density of air $f_a=1.2$ kg m⁻³,

$g=10$ m/s²

Coefficient of viscosity of air = 1.8×10^{-5} Nsm⁻²]

Options :

1. 250.6 ms⁻¹
2. 4.94 ms⁻¹
3. 14.4 ms⁻¹
4. 43.56 ms⁻¹

Question Type : MCQ Is Question Mandatory : No

Correct Marks : 4 Wrong Marks : 1

ଭୂମିଠାରୁ 2000 m ଉଚ୍ଚତା (h) ରେ ଥିବା ଏକ ମେଘରୁ 0.2 mm ବ୍ୟାସାର୍ଦ୍ଧ R ବିଶିଷ୍ଟ ଗୋଟିଏ ବର୍ଷା ବୁନ୍ଦା ଖସୁଅଛି । ଧରିନିଅ ଯେ, ବୁନ୍ଦାଟି ତମାମ୍ ପତନ ସମୟରେ ଗୋଲାକାର ରହିଛି ଏବଂ ଏହାର ଉର୍ଦ୍ଧ୍ୱଗାମୀ ବଳକୁ ବିଚାରକୁ ନେବ ନାହିଁ । ତା'ହେଲେ ବୁନ୍ଦା ଦ୍ୱାରା ପ୍ରାପ୍ତ ଅତିମ ପରିବେଗ (ଚରମନାଲ୍ ସ୍ପିଡ୍) ହେଉଛି :

(ଜଳର ସାନ୍ଦ୍ରତା $f_w = 1000 \text{ kg m}^{-3}$

ଏବଂ ବାୟୁର ସାନ୍ଦ୍ରତା $f_a = 1.2 \text{ kg m}^{-3}$,

$g = 10 \text{ m/s}^2$

ବାୟୁର ଗାଢ଼ତ୍ୱ ସ୍ଥୂବାଙ୍କ $= 1.8 \times 10^{-5} \text{ Nsm}^{-2}$)

Options :

1. 250.6 ms^{-1}

2. 4.94 ms^{-1}

3. 14.4 ms^{-1}

4. 43.56 ms^{-1}

Question Type : MCQ Is Question Mandatory : No

Correct Marks : 4 Wrong Marks : 1

A physical quantity ' y ' is represented by the formula $y = m^2 r^{-4} g^x l^{-\frac{3}{2}}$

If the percentage errors found in y , m , r , l and g are 18, 1, 0.5, 4 and p respectively, then find the value of x and p .

Options :

1. 4 and ± 3

2. 5 and ± 2

3. 8 and ± 2

4. $\frac{16}{3}$ and $\pm \frac{3}{2}$

Question Type : MCQ Is Question Mandatory : No

Correct Marks : 4 Wrong Marks : 1

ସୂତ୍ର $y = m^2 r^{-4} g^x l^{-\frac{3}{2}}$ ଦ୍ୱାରା ଏକ ଭୌତିକ ରାଶି 'y' କୁ ପ୍ରଦର୍ଶନ କରାଯାଇଛି । ଯଦି y, m, r, l ଏବଂ g ରେ ମିଳୁଥିବା ଶତକଡ଼ା ତ୍ରୁଟିଗୁଡ଼ିକ ଯଥାକ୍ରମେ 18, 1, 0.5, 4 ଏବଂ p , ତେବେ x ଏବଂ p ର ମୂଲ୍ୟ ବାହାର କର ।

Options :

1. 4 ଏବଂ ± 3

2. 5 ଏବଂ ± 2

3. 8 ଏବଂ ± 2

4. $\frac{16}{3}$ ଏବଂ $\pm \frac{3}{2}$

Question Type : MCQ Is Question Mandatory : No

Correct Marks : 4 Wrong Marks : 1

Two Carnot engines A and B operate in series such that engine A absorbs heat at T_1 and rejects heat to a sink at temperature T . Engine B absorbs half of the heat rejected by Engine A and rejects heat to the sink at T_3 . When workdone in both the cases is equal, the value of T is :

Options :

1. $\frac{2}{3}T_1 + \frac{1}{3}T_3$

2. $\frac{3}{2}T_1 + \frac{1}{3}T_3$

3. $\frac{2}{3}T_1 + \frac{3}{2}T_3$

4. $\frac{1}{3}T_1 + \frac{2}{3}T_3$

Question Type : MCQ Is Question Mandatory : No

Correct Marks : 4 Wrong Marks : 1

ଦୁଇଟି କାରନର୍ ଇଞ୍ଜିନ୍ A ଏବଂ B ପଛକୁ ପଛ (ସିରିଜ୍ରେ) କାର୍ଯ୍ୟ କରୁଛନ୍ତି ଯେମିତିକି ଇଞ୍ଜିନ୍ A ତାପମାତ୍ରା T_1 ରେ ତାପ ଶୋଷିତ କରୁଛି ଏବଂ ତାପମାତ୍ରା T ରେ ସିଙ୍କକୁ ଛାଡୁଛି । ଇଞ୍ଜିନ୍ B ଟି ଇଞ୍ଜିନ୍ A ଛାଡ଼ିଥିବା ତାପର ଅଧା ଶୋଷିତ କରୁଛି ଏବଂ T_3 ତାପମାତ୍ରାରେ ସିଙ୍କକୁ ତାପ ଛାଡୁଛି । ଯେତେବେଳେ ଉଭୟ କ୍ଷେତ୍ରରେ ସମାଦିତ କାର୍ଯ୍ୟ ସମାନ ହୁଏ, T ର ମୂଲ୍ୟ ହେବ :

Options :

1. $\frac{2}{3}T_1 + \frac{1}{3}T_3$

2. $\frac{3}{2}T_1 + \frac{1}{3}T_3$

3. $\frac{2}{3}T_1 + \frac{3}{2}T_3$

4.

$$\frac{1}{3}T_1 + \frac{2}{3}T_3$$

Question Type : MCQ Is Question Mandatory : No

Correct Marks : 4 Wrong Marks : 1

The planet Mars has two moons, if one of them has a period 7 hours, 30 minutes and an orbital radius of 9.0×10^3 km. Find the mass of Mars.

$$\left\{ \text{Given } \frac{4\pi^2}{G} = 6 \times 10^{11} \text{ N}^{-1} \text{ m}^{-2} \text{ kg}^2 \right\}$$

Options :

1. $5.96 \times 10^{19} \text{ kg}$
2. $3.25 \times 10^{21} \text{ kg}$
3. $6.00 \times 10^{23} \text{ kg}$
4. $7.02 \times 10^{25} \text{ kg}$

Question Type : MCQ Is Question Mandatory : No

Correct Marks : 4 Wrong Marks : 1

ମଙ୍ଗଳ ଗ୍ରହର ଦୁଇଟି ଚନ୍ଦ୍ର ଅଛି, ଯଦି ସେମାନଙ୍କ ମଧ୍ୟରୁ ଗୋଟିକର ପରିକ୍ରମଣ କାଳ 7 ଘଣ୍ଟା 30 ମିନିଟ୍ ଏବଂ କକ୍ଷପଥର ବ୍ୟାସାର୍ଦ୍ଧ 9.0×10^3 km ହୁଏ, ତେବେ ମଙ୍ଗଳ ଗ୍ରହର ବସ୍ତୁତ୍ୱ ବାହାର କର ।

$$\left\{ \text{ଦତ୍ତ : } \frac{4\pi^2}{G} = 6 \times 10^{11} \text{ N}^{-1} \text{ m}^{-2} \text{ kg}^2 \right\}$$

Options :

1. $5.96 \times 10^{19} \text{ kg}$

2. $3.25 \times 10^{21} \text{ kg}$

3. $6.00 \times 10^{23} \text{ kg}$

4. $7.02 \times 10^{25} \text{ kg}$

Question Type : MCQ Is Question Mandatory : No

Correct Marks : 4 Wrong Marks : 1

An object of mass 0.5 kg is executing simple harmonic motion. Its amplitude is 5 cm and time period (T) is 0.2 s. What will be the potential energy of the object at an instant $t = \frac{T}{4}$ s starting from mean position. Assume that the initial phase of the oscillation is zero.

Options :

1. $6.2 \times 10^{-3} \text{ J}$

2. $1.2 \times 10^3 \text{ J}$

3. 0.62 J

4. $6.2 \times 10^3 \text{ J}$

Question Type : MCQ Is Question Mandatory : No

Correct Marks : 4 Wrong Marks : 1

0.5 kg ବସ୍ତୁ ବିଶିଷ୍ଟ ଏକ ବସ୍ତୁ ସରଳ ହାରମୋନିକ୍ ଗତି ନିର୍ବାହ କରୁଅଛି । ଏହାର ଆୟାମ 5 cm ଏବଂ ଆବର୍ତ୍ତ କାଳ (T)

0.2 s ଅଟେ । ଯେତେବେଳେ ବସ୍ତୁ $t = \frac{T}{4}$ ସମୟରେ ଏହାର ସନ୍ତୁଳନ ସ୍ଥାନ ଠାରୁ 5 cm ଦୂରତାରେ ଥିବ, ଏହାର ସ୍ଥିତିଜ

ଶକ୍ତିର ପରିମାଣ କେତେ ହେବ ? ସନ୍ତୁଳନ ଅବସ୍ଥିତି ଆରମ୍ଭରେ ଦୋଳନର ପ୍ରାରମ୍ଭିକ କଳା (ଫେଜ) ଶୂନ୍ୟ ବୋଲି ବିବେଚନା କର ।

Options :

1. $6.2 \times 10^{-3} \text{ J}$
2. $1.2 \times 10^3 \text{ J}$
3. 0.62 J
4. $6.2 \times 10^3 \text{ J}$

Question Type : MCQ Is Question Mandatory : No

Correct Marks : 4 Wrong Marks : 1

An automobile of mass ' m ' accelerates starting from origin and initially at rest, while the engine supplies constant power P . The position is given as a function of time by :

Options :

1. $\left(\frac{9P}{8m}\right)^{\frac{1}{2}} t^{\frac{3}{2}}$
2. $\left(\frac{8P}{9m}\right)^{\frac{1}{2}} t^{\frac{2}{3}}$
- 3.

$$\left(\frac{8P}{9m}\right)^{\frac{1}{2}} t^{\frac{3}{2}}$$

4. $\left(\frac{9m}{8P}\right)^{\frac{1}{2}} t^{\frac{3}{2}}$

Question Type : MCQ Is Question Mandatory : No

Correct Marks : 4 Wrong Marks : 1

'm' ବସ୍ତୁର ବିଶିଷ୍ଟ ଏକ ସ୍ଵୟଂଚାଳିତ ଯାନ (ଅଟୋମୋବାଇଲ) ସ୍ଥିର ଅବସ୍ଥାରୁ ଆରମ୍ଭ କରି ତ୍ଵରିତ ଗତିରେ ଯାଉଛି, ଯେତେବେଳେ ଇଞ୍ଜିନ୍‌ଟି ସ୍ଥିର କ୍ଷମତା P ଯୋଗାଉଛି । ସମୟ (t) ଅନୁସାରେ ଅବସ୍ଥିତିକୁ କିପରି ବର୍ଣ୍ଣାୟାଇପାରିବ ?

Options :

1. $\left(\frac{9P}{8m}\right)^{\frac{1}{2}} t^{\frac{3}{2}}$

2. $\left(\frac{8P}{9m}\right)^{\frac{1}{2}} t^{\frac{2}{3}}$

3. $\left(\frac{8P}{9m}\right)^{\frac{1}{2}} t^{\frac{3}{2}}$

4. $\left(\frac{9m}{8P}\right)^{\frac{1}{2}} t^{\frac{3}{2}}$

Question Type : MCQ Is Question Mandatory : No

Correct Marks : 4 Wrong Marks : 1

Figure A and B show two long straight wires of circular cross-section (a and b with $a < b$), carrying current I which is uniformly distributed across the cross-section. The magnitude of magnetic field B varies with radius r and can be represented as :

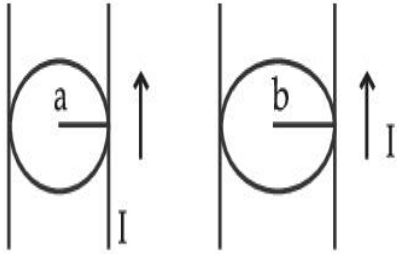
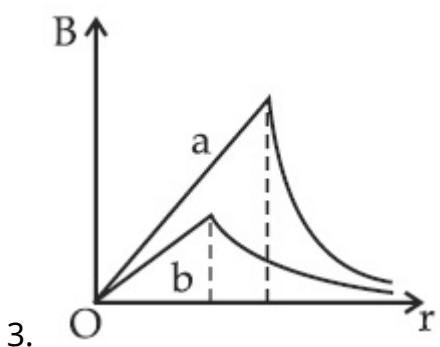
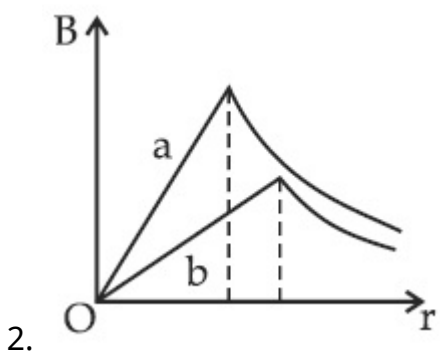
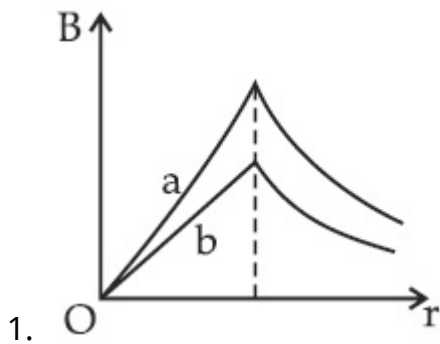
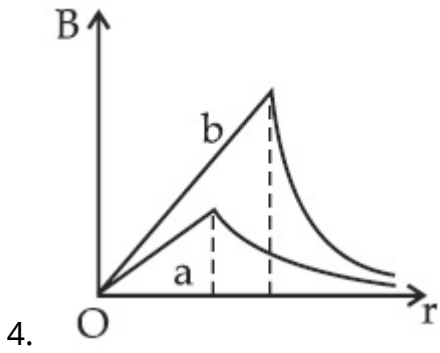

Fig. A

Fig. B

Options :





Question Type : MCQ Is Question Mandatory : No

Correct Marks : 4 Wrong Marks : 1

ଚିତ୍ର A ଏବଂ B ଦୁଇଟି ବୃତ୍ତାକାର ପ୍ରସ୍ଥଲେଦ (a ଏବଂ b ଯେଉଁଠି $a < b$) ଥିବା ଦୁଇଟି ଲମ୍ବା ଓ ସିଧା ତାରକୁ ଦର୍ଶାଉଛି, I ପରିମାଣର ବିଦ୍ୟୁତ୍ ସ୍ରୋତ ପରିବହନ କରୁଛନ୍ତି ଯାହାକି ପ୍ରସ୍ଥଲେଦରେ ସମାନ ଭାବରେ ବଣ୍ଟନ ହୋଇଛି । ଚୁମ୍ବକୀୟ କ୍ଷେତ୍ର B ର ପରିମାଣ ବ୍ୟାସାର୍ଦ୍ଧ r ସହ ପରିବର୍ତ୍ତିତ ହେଉଛି ଏବଂ କିଭଳି ଦର୍ଶାଯିବ ?

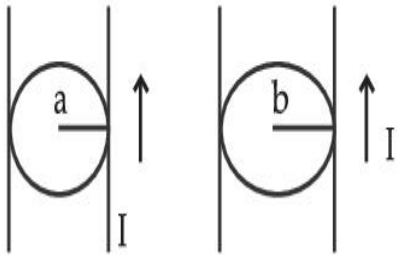
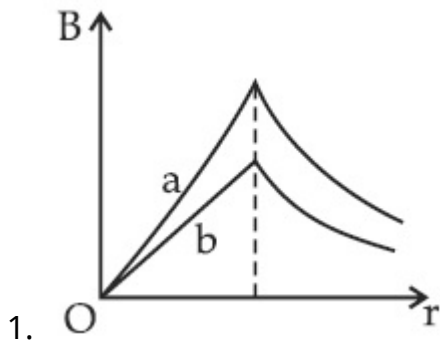

Fig. A

Fig. B

Options :



2.

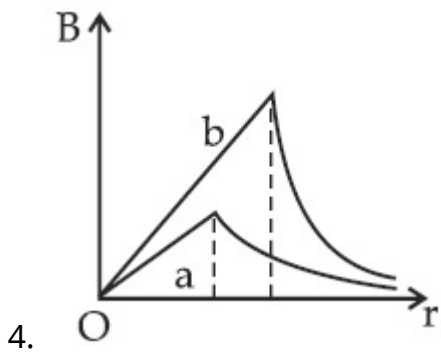
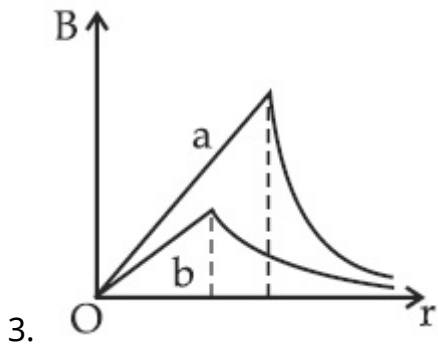
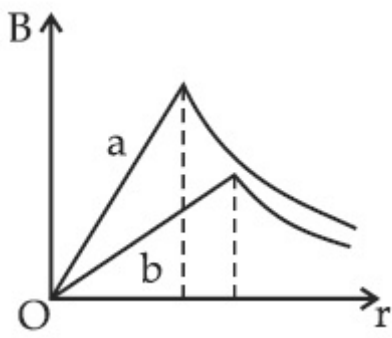

Question Type : MCQ Is Question Mandatory : No

Correct Marks : 4 Wrong Marks : 1

Two identical particles of mass 1 kg each go round a circle of radius R , under the action of their mutual gravitational attraction. The angular speed of each particle is :

Options :

1. $\sqrt{\frac{G}{2R^3}}$

2.

$$\frac{1}{2} \sqrt{\frac{G}{R^3}}$$

3. $\frac{1}{2R} \sqrt{\frac{1}{G}}$

4. $\sqrt{\frac{2G}{R^3}}$

Question Type : MCQ Is Question Mandatory : No

Correct Marks : 4 Wrong Marks : 1

ପରସ୍ପରର ମହାକର୍ଷଣୀୟ ଆକର୍ଷଣ ପ୍ରଭାବରୁ 1 kg ବସ୍ତୁରୁ ବିଶିଷ୍ଟ ଦୁଇଟି କଣିକା R ବ୍ୟାସାର୍ଦ୍ଧ ବିଶିଷ୍ଟ ଏକ ବୃତ୍ତରେ ଗତି କରୁଛନ୍ତି । ପ୍ରତ୍ୟେକ କଣିକାର କୌଣସି ବେଗ ହେବ :

Options :

1. $\sqrt{\frac{G}{2R^3}}$

2. $\frac{1}{2} \sqrt{\frac{G}{R^3}}$

3. $\frac{1}{2R} \sqrt{\frac{1}{G}}$

4. $\sqrt{\frac{2G}{R^3}}$

Question Type : MCQ Is Question Mandatory : No

Correct Marks : 4 Wrong Marks : 1

An electron and proton are separated by a large distance. The electron starts approaching the proton with energy 3 eV. The proton captures the electron and forms a hydrogen atom in second excited state. The resulting photon is incident on a photosensitive metal of threshold wavelength 4000 Å. What is the maximum kinetic energy of the emitted photoelectron?

Options :

1. 3.3 eV
2. No photoelectron would be emitted
3. 7.61 eV
4. 1.41 eV

Question Type : MCQ Is Question Mandatory : No

Correct Marks : 4 Wrong Marks : 1

ଗୋଟିଏ ଇଲେକ୍ଟ୍ରନ୍ ଓ ପ୍ରୋଟନ୍ କୁ ବହୁତ ଦୂରରେ ରଖାଯାଇଛି । ଇଲେକ୍ଟ୍ରନ୍ ଟି ପ୍ରୋଟନ୍ ଆଡ଼କୁ 3 eV ଶକ୍ତି ସହ ନିକଟତର ହେଉଛି । ପ୍ରୋଟନ୍ ଟି ଇଲେକ୍ଟ୍ରନ୍ କୁ ଧରୁଛି ଏବଂ ଦ୍ୱିତୀୟ ଉତ୍ତମ ସ୍ଥରରେ ଥିବା ଗୋଟିଏ ହାଇଡ୍ରୋଜେନ୍ ପରମାଣୁ ତିଆରି କରୁଛି । ପରିଣାମୀ ପ୍ରୋଟନ୍ ଟି 4000 Å ପ୍ରଭାବସୀମା ତରଙ୍ଗ ଦୈର୍ଘ୍ୟ ଥିବା ଗୋଟିଏ ଆଲୋକ ସଂବେଦୀ ଧାତୁରେ ପଡ଼ୁଛି । ଉତ୍ସର୍ଜିତ ଫଟୋଇଲେକ୍ଟ୍ରନ୍ ସର୍ବାଧିକ ଗତିଜ ଶକ୍ତି କେତେ ହେବ ?

Options :

1. 3.3 eV
2. କୌଣସି ଫଟୋଇଲେକ୍ଟ୍ରନ୍ ବାହାରିବ ନାହିଁ
3. 7.61 eV

4. 1.41 eV

Question Type : MCQ Is Question Mandatory : No

Correct Marks : 4 Wrong Marks : 1

The expected graphical representation of the variation of angle of deviation ' δ ' with angle of incidence ' i ' in a prism is :

Options :

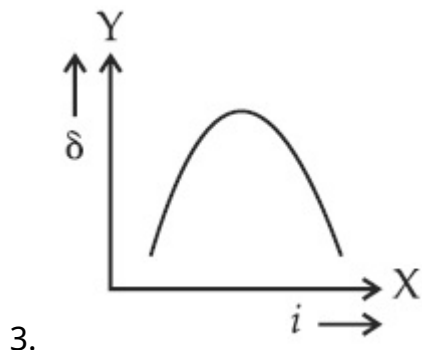
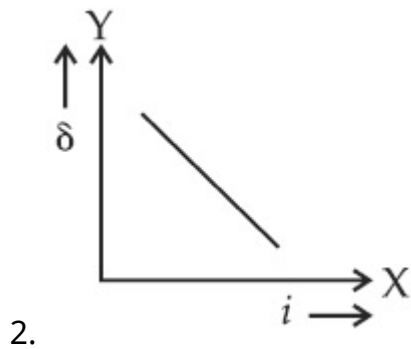
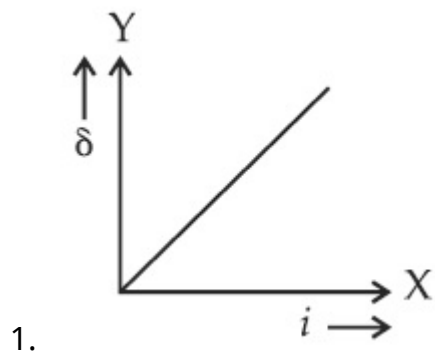

4.

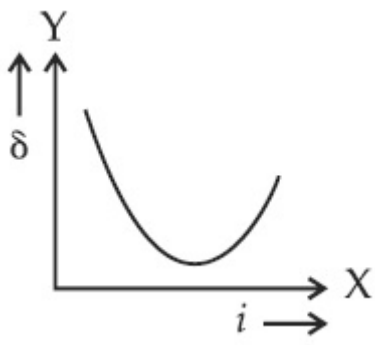

Question Type : MCQ Is Question Mandatory : No

Correct Marks : 4 Wrong Marks : 1

ଗୋଟିଏ ପ୍ରିଜମରେ ଆପତିତ କୋଣ 'i' ସହ ବିଚଳନ କୋଣ 'δ' ର ପରିବର୍ତ୍ତନର ସମ୍ଭାବ୍ୟ ଲେଖାଚିତ୍ରର ପ୍ରଦର୍ଶନ ହେବ :

Options :

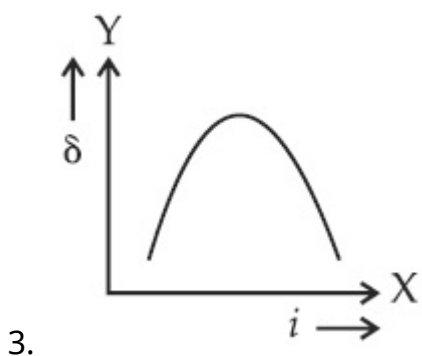
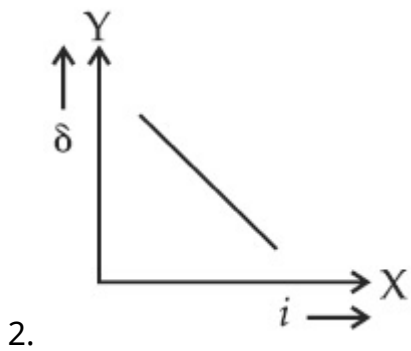
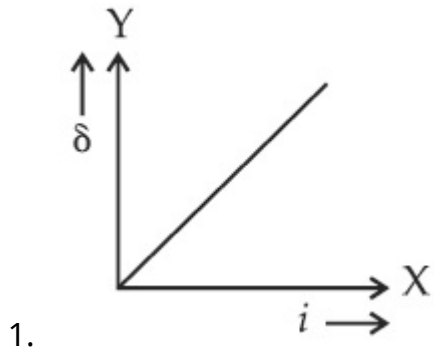

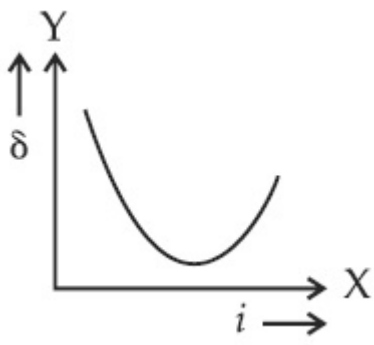

4.

Question Type : MCQ Is Question Mandatory : No

Correct Marks : 4 Wrong Marks : 1

A 100Ω resistance, a $0.1 \mu\text{F}$ capacitor and an inductor are connected in series across a 250 V supply at variable frequency. Calculate the value of inductance of inductor at which resonance will occur. Given that the resonant frequency is 60 Hz .

Options :

1. $7.03 \times 10^{-5} \text{ H}$
2. 70.3 H
3. 0.70 H
4. 70.3 mH

Question Type : MCQ Is Question Mandatory : No

Correct Marks : 4 Wrong Marks : 1

ପରିବର୍ତ୍ତନଶୀଳ ଆବୃତ୍ତିରେ ଥିବା 250 V ର ଏକ ଉତ୍ସର ଦୁଇ ପ୍ରାନ୍ତରେ ଗୋଟିଏ 100Ω ର ପ୍ରତିରୋଧ, ଗୋଟିଏ $0.1 \mu\text{F}$ ର ଧାରିତା ଏବଂ ଏକ ପ୍ରଶୋଦକକୁ ଶ୍ରେଣୀରେ ସଂଯୁକ୍ତ କରାଯାଇଛି । ଅନୁନାଦ ହେଉଥିବା ସ୍ଥଳେ ପ୍ରଶୋଦକଟିର ମୂଲ୍ୟ କଳନା କର । ଅନୁନାଦ ଆବୃତ୍ତି 60 Hz ବୋଲି ଦିଆଯାଇଛି ।

Options :

1. $7.03 \times 10^{-5} \text{ H}$

2. 70.3 H
3. 0.70 H
4. 70.3 mH

Question Type : MCQ Is Question Mandatory : No

Correct Marks : 4 Wrong Marks : 1

The resistance of a conductor at 15°C is $16\ \Omega$ and at 100°C is $20\ \Omega$. What will be the temperature coefficient of resistance of the conductor ?

Options :

1. $0.003^{\circ}\text{C}^{-1}$
2. $0.010^{\circ}\text{C}^{-1}$
3. $0.033^{\circ}\text{C}^{-1}$
4. $0.042^{\circ}\text{C}^{-1}$

Question Type : MCQ Is Question Mandatory : No

Correct Marks : 4 Wrong Marks : 1

ଗୋଟିଏ ପରିବାହୀର ବିଦ୍ୟୁତ୍ ପ୍ରତିରୋଧକ 15°C ତାପମାତ୍ରାରେ $16\ \Omega$ ଏବଂ 100°C ତାପମାତ୍ରାରେ $20\ \Omega$ ଅଟେ । ପରିବାହୀଟିର ବିଦ୍ୟୁତ୍ ପ୍ରତିରୋଧକ ତାପମାତ୍ରା ଧ୍ରୁବାଙ୍କ କେତେ ହେବ ?

Options :

1. $0.003^{\circ}\text{C}^{-1}$

2. $0.010^{\circ}\text{C}^{-1}$

3. $0.033^{\circ}\text{C}^{-1}$

4. $0.042^{\circ}\text{C}^{-1}$

Question Type : MCQ Is Question Mandatory : No

Correct Marks : 4 Wrong Marks : 1

What will be the magnitude of electric field at point O as shown in figure ? Each side of the figure is l and perpendicular to each other ?

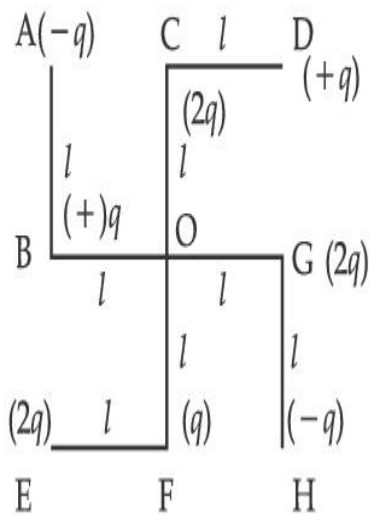

Options :

1. $\frac{1}{4\pi\epsilon_0} \frac{q}{l^2}$

2. $\frac{1}{4\pi\epsilon_0} \frac{2q}{2l^2}(\sqrt{2})$

3. $\frac{1}{4\pi\epsilon_0} \frac{q}{(2l^2)}(2\sqrt{2} - 1)$

4. $\frac{q}{4\pi\epsilon_0(2l)^2}$

Question Type : MCQ Is Question Mandatory : No

Correct Marks : 4 Wrong Marks : 1

ଚିତ୍ରରେ ଦର୍ଶାଯାଇଥିବା O ବିନ୍ଦୁରେ ବିଦ୍ୟୁତ୍ କ୍ଷେତ୍ରର ପରିମାଣ କେତେ ହେବ ? ଚିତ୍ରଟିର ପ୍ରତ୍ୟେକ ପାର୍ଶ୍ୱ l ଏବଂ ପରସ୍ପରକୁ ଲମ୍ବ ଅଟନ୍ତି ।

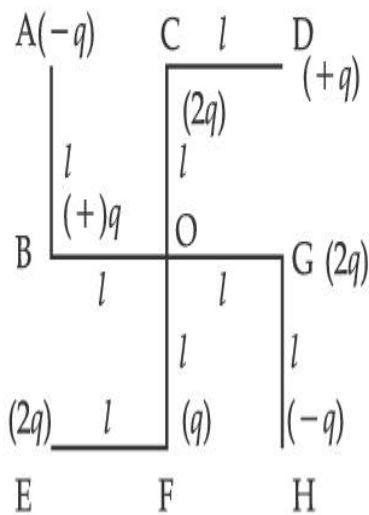

Options :

1. $\frac{1}{4\pi\epsilon_0} \frac{q}{l^2}$

2. $\frac{1}{4\pi\epsilon_0} \frac{2q}{2l^2}(\sqrt{2})$

3. $\frac{1}{4\pi\epsilon_0} \frac{q}{(2l^2)}(2\sqrt{2} - 1)$

4.

$$\frac{q}{4\pi\epsilon_0(2l)^2}$$

Physics Section B

Section Id :	864351849
Section Number :	2
Section type :	Online
Mandatory or Optional :	Mandatory
Number of Questions :	10
Number of Questions to be attempted :	5
Section Marks :	20
Enable Mark as Answered Mark for Review and Clear Response :	Yes
Sub-Section Number :	1
Sub-Section Id :	8643511076
Question Shuffling Allowed :	Yes

Question Type : SA

Correct Marks : 4 Wrong Marks : 0

The maximum amplitude for an amplitude modulated wave is found to be 12 V while the minimum amplitude is found to be 3 V. The modulation index is $0.6x$ where x is _____.

Response Type : Numeric

Evaluation Required For SA : Yes

Show Word Count : Yes

Answers Type : Equal

Text Areas : PlainText

Possible Answers :

1

Question Type : SA

Correct Marks : 4 Wrong Marks : 0

ଗୋଟିଏ ଆକାମ ମତ୍ତୁଲନ୍ ତରଙ୍ଗରେ ସର୍ବାଧିକ ଆକାମ 12 V ହୋଇଥାଏ ଯେତେବେଳେ ସର୍ବନିମ୍ନ ଆକାମ 3 V ମିଳିଥାଏ । ମତ୍ତୁଲେସନ୍ ଇଣ୍ଡେକ୍ସ $0.6x$ ଅଟେ ଯେଉଁଠାରେ x ହେଉଛି _____ ।

Response Type : Numeric

Evaluation Required For SA : Yes

Show Word Count : Yes

Answers Type : Equal

Text Areas : PlainText

Possible Answers :

1

Question Type : SA

Correct Marks : 4 Wrong Marks : 0

For the circuit shown, the value of current at time $t=3.2$ s will be _____ A.

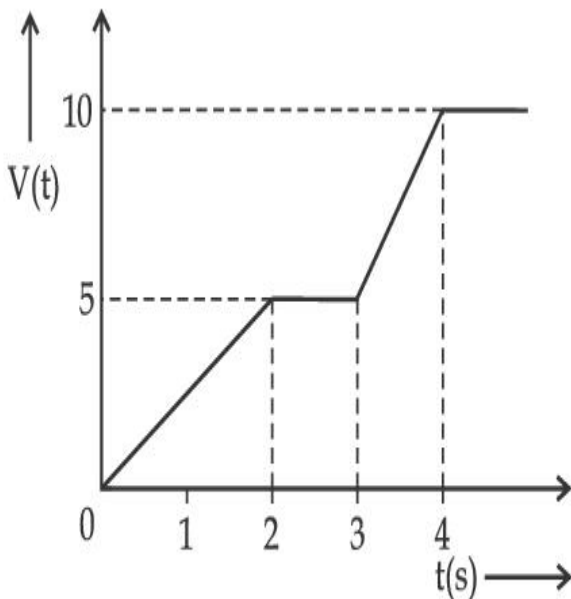

Figure 1

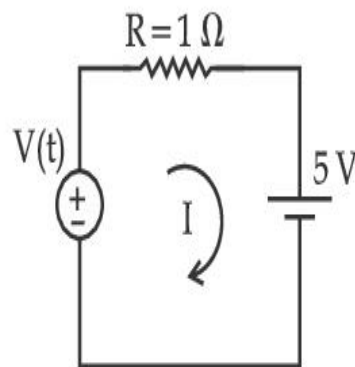

Figure 2

[Voltage distribution $V(t)$ is shown by Fig. (1) and the circuit is shown in Fig. (2)]

Response Type : Numeric

Evaluation Required For SA : Yes

Show Word Count : Yes

Answers Type : Equal

Text Areas : PlainText

Possible Answers :

1

Question Type : SA

Correct Marks : 4 Wrong Marks : 0

ଦର୍ଶାଯାଇଥିବା ପରିପଥଟିରେ, ସମୟ $t=3.2$ s ରେ ବିଦ୍ୟୁତ୍ ସ୍ରୋତର ପରିମାଣ ହେବ _____ A ।

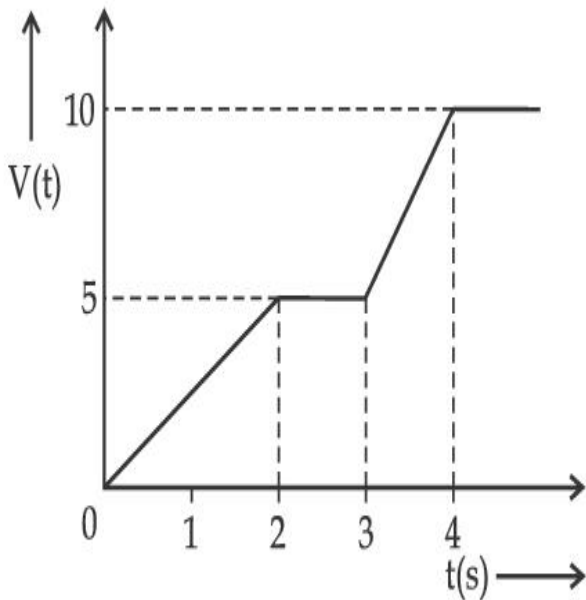

Figure 1

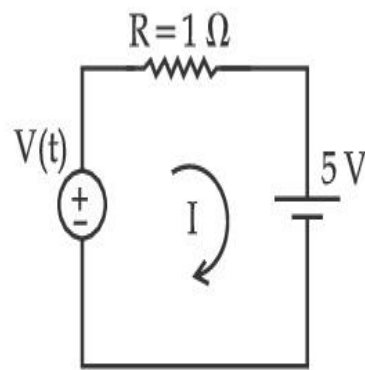

Figure 2

(ଚିତ୍ର (1) ରେ ବିଭବ ବଣ୍ଟନ $V(t)$ କୁ ଦର୍ଶାଯାଇଛି ଏବଂ ଚିତ୍ର (2) ରେ ବିଦ୍ୟୁତ୍ ପରିପଥକୁ ଦର୍ଶାଯାଇଛି)

Response Type : Numeric

Evaluation Required For SA : Yes

Show Word Count : Yes

Answers Type : Equal

Text Areas : PlainText

Possible Answers :

1

Question Type : SA

Correct Marks : 4 Wrong Marks : 0

In the given figure the magnetic flux through the loop increases according to the relation $\phi_B(t) = 10t^2 + 20t$, where ϕ_B is in milliwebers and t is in seconds.

The magnitude of current through $R = 2 \Omega$ resistor at $t = 5$ s is _____ mA.

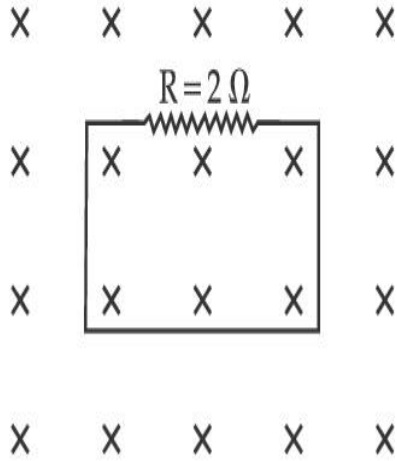

Response Type : Numeric

Evaluation Required For SA : Yes

Show Word Count : Yes

Answers Type : Equal

Text Areas : PlainText

Possible Answers :

1

Question Type : SA

Correct Marks : 4 Wrong Marks : 0

ଦତ୍ତ ଚିତ୍ରରେ, ଗୋଟିଏ ଲୁଚ୍ ମଧ୍ୟରେ ରୁମ୍‌କାନ୍ଥ ଅଭିବାହ $\phi_B(t) = 10t^2 + 20t$ ଅନୁସାରେ ବୃଦ୍ଧି ପାଉଛି, ଯେଉଁଠାରେ ϕ_B ମିଲି ଟେସ୍‌ର ଏବଂ t ସେକେଣ୍ଡରେ ରହିଛି । $t = 5$ s ରେ ପ୍ରତିରୋଧକ $R = 2 \Omega$ ମଧ୍ୟରେ ବିଦ୍ୟୁତ୍ ସ୍ରୋତର ପରିମାଣ ହେଉଛି _____ mA ।

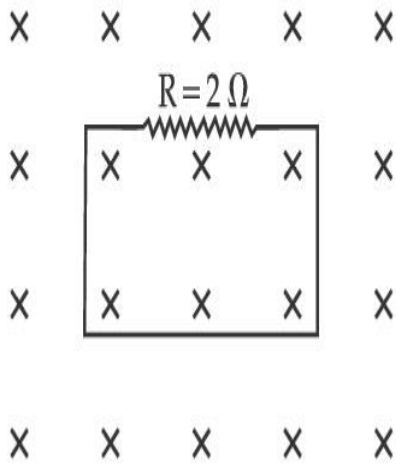

Response Type : Numeric

Evaluation Required For SA : Yes

Show Word Count : Yes

Answers Type : Equal

Text Areas : PlainText

Possible Answers :

1

Question Type : SA

Correct Marks : 4 **Wrong Marks :** 0

The K_α X-ray of molybdenum has wavelength 0.071 nm. If the energy of a molybdenum atom with a K electron knocked out is 27.5 keV, the energy of this atom when an L electron is knocked out will be _____ keV. (Round off to the nearest integer)

[$h = 4.14 \times 10^{-15}$ eVs, $c = 3 \times 10^8$ ms⁻¹]

Response Type : Numeric

Evaluation Required For SA : Yes

Show Word Count : Yes

Answers Type : Equal

Text Areas : PlainText

Possible Answers :

1

Question Type : SA

Correct Marks : 4 Wrong Marks : 0

ମଲିବିଡ଼ିୟମ୍ K_{α} ଏକ୍ସରେର ତରଙ୍ଗ ଦୈର୍ଘ୍ୟ 0.071 nm ଅଟେ । ଯଦି ଗୋଟିଏ K ଇଲେକ୍ଟ୍ରନ୍ ଧକ୍କା ଖାଇ ବାହାରିଲା ବେଳେ ମଲିବିଡ଼ିୟମ୍ ପରମାଣୁର ଶକ୍ତି 27.5 keV ହୁଏ, ତେବେ ଯେତେବେଳେ L ଇଲେକ୍ଟ୍ରନ୍ ଧକ୍କା ଖାଇ ବାହରୁଥିବା ମଲିବିଡ଼ିୟମ୍ ପରମାଣୁର ଶକ୍ତି ହେବ _____ keV । (ନିକଟତମ ପୂର୍ଣ୍ଣସଂଖ୍ୟାରେ ପରିଣତ କର)

[$h = 4.14 \times 10^{-15} \text{ eVs}$, $c = 3 \times 10^8 \text{ ms}^{-1}$]

Response Type : Numeric

Evaluation Required For SA : Yes

Show Word Count : Yes

Answers Type : Equal

Text Areas : PlainText

Possible Answers :

1

Question Type : SA

Correct Marks : 4 Wrong Marks : 0

The water is filled upto height of 12 m in a tank having vertical sidewalls. A hole is made in one of the walls at a depth ' h ' below the water level. The value of ' h ' for which the emerging stream of water strikes the ground at the maximum range is _____ m .

Response Type : Numeric

Evaluation Required For SA : Yes

Show Word Count : Yes

Answers Type : Equal

Text Areas : PlainText

Possible Answers :

1

Question Type : SA

Correct Marks : 4 Wrong Marks : 0

ଭୂଲମ୍ବ ପାର୍ଶ୍ୱ କାନ୍ଥ ଥିବା ଗୋଟିଏ ଚାକିରେ 12 m ଉଚ୍ଚତାର ଜଳ ରହିଅଛି । ଜଳସ୍ତରର 'h' ଗଭୀରତାରେ ଗୋଟିଏ ପଟ କାନ୍ଥରେ ଛିଦ୍ରଟିଏ କରାଗଲା । ଯଦି ବାହାରୁଥିବା ଜଳସ୍ରୋତ ଭୂମି ଉପରେ ସର୍ବାଧିକ ଦୂରତାରେ ପଡ଼ୁଛି, ତେବେ 'h' ମୂଲ୍ୟ ହେବ _____ m ।

Response Type : Numeric

Evaluation Required For SA : Yes

Show Word Count : Yes

Answers Type : Equal

Text Areas : PlainText

Possible Answers :

1

Question Type : SA

Correct Marks : 4 Wrong Marks : 0

In the given figure, two wheels P and Q are connected by a belt B. The radius of P is three times as that of Q. In case of same rotational kinetic energy, the ratio of rotational inertias

$\left(\frac{I_1}{I_2}\right)$ will be $x : 1$. The value of x will be _____.

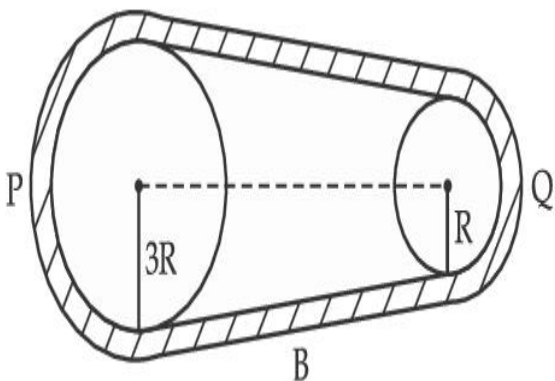

Response Type : Numeric

Evaluation Required For SA : Yes

Show Word Count : Yes

Answers Type : Equal

Text Areas : PlainText

Possible Answers :

1

Question Type : SA

Correct Marks : 4 Wrong Marks : 0

ଦଉଳ ଚିତ୍ରରେ, ଦୁଇଟି ଚକ P ଏବଂ Q ଗୋଟିଏ ବେଲ୍ B ଦ୍ୱାରା ସଂଯୁକ୍ତ ହୋଇଛନ୍ତି । P ର ବ୍ୟାସାର୍ଦ୍ଧ Q ବ୍ୟାସାର୍ଦ୍ଧର ତିନିଗୁଣ ଅଟେ । ସମାନ ଦୂର୍ଣ୍ଣନ ଗତିଜ ଶକ୍ତି କ୍ଷେତ୍ରରେ $\left(\frac{I_1}{I_2}\right)$, ଦୂର୍ଣ୍ଣନ ଜଡ଼ତାର ଅନୁପାତ $x:1$ ହେବ. ଯେଉଁଠାରେ x ର ମୂଲ୍ୟ ହେଉଛି

_____ ।

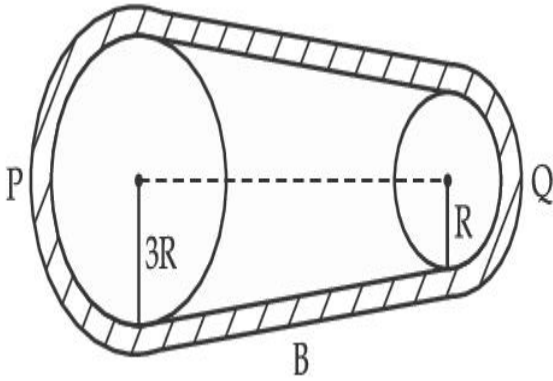

Response Type : Numeric

Evaluation Required For SA : Yes

Show Word Count : Yes

Answers Type : Equal

Text Areas : PlainText

Possible Answers :

1

Question Type : SA

Correct Marks : 4 Wrong Marks : 0

A small block slides down from the top of hemisphere of radius $R=3$ m as shown in the figure. The height 'h' at which the block will lose contact with the surface of the sphere is _____ m.

(Assume there is no friction between the block and the hemisphere)

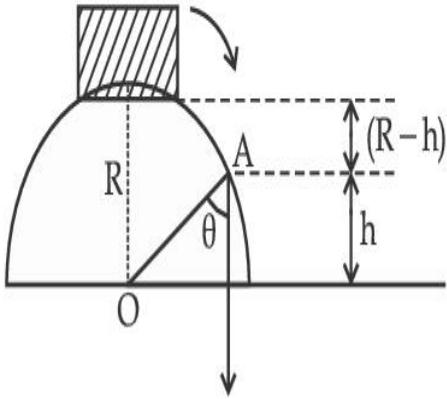

Response Type : Numeric

Evaluation Required For SA : Yes

Show Word Count : Yes

Answers Type : Equal

Text Areas : PlainText

Possible Answers :

1

Question Type : SA

Correct Marks : 4 **Wrong Marks :** 0

ଦର୍ଶାଯାଇଥିବା ଅନୁସାରେ, ଗୋଟିଏ ଛୋଟ ବୁକ୍ଟିଏ ବ୍ୟାସାର୍ଦ୍ଧ $R=3\text{ m}$ ବିଶିଷ୍ଟ ଗୋଟିଏ ଅର୍ଦ୍ଧଗୋଲକର ଶୀର୍ଷରୁ ତଳକୁ ଖସୁଛି । (ଚିତ୍ରରେ ଦର୍ଶାଯାଇଛି) ଯେଉଁଠାରେ ବୁକ୍ଟି ଗୋଲକର ପୃଷ୍ଠତଳ ସହ ସମ୍ପର୍କ ଛିନ୍ନ କରୁଛି, ସେହି ଉଚ୍ଚତା 'h' ର ମୂଲ୍ୟ ହେଉଛି _____ m ।

(ଧରିନିଅ ଯେ, ବୁକ୍ଟି ଏବଂ ଅର୍ଦ୍ଧ ଗୋଲକ ମଧ୍ୟରେ କୌଣସି ଘର୍ଷଣ ହେଉନାହିଁ)

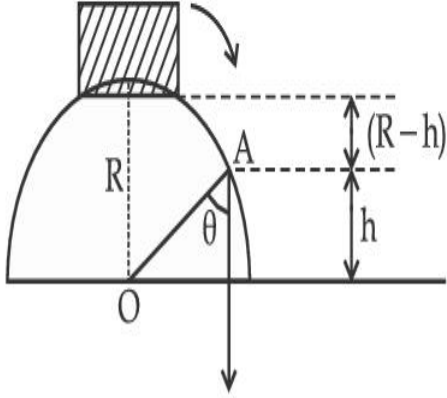

Response Type : Numeric

Evaluation Required For SA : Yes

Show Word Count : Yes

Answers Type : Equal

Text Areas : PlainText

Possible Answers :

1

Question Type : SA

Correct Marks : 4 **Wrong Marks :** 0

A swimmer wants to cross a river from point A to point B. Line AB makes an angle of 30° with the flow of river. Magnitude of velocity of the swimmer is same as that of the river. The angle θ with the line AB should be _____ $^\circ$, so that the swimmer reaches point B.

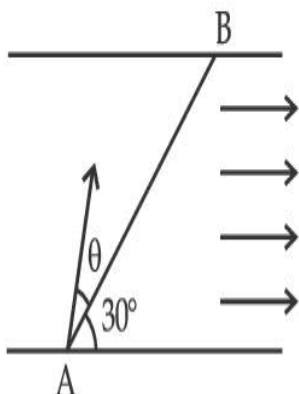

Response Type : Numeric

Evaluation Required For SA : Yes

Show Word Count : Yes

Answers Type : Equal

Text Areas : PlainText

Possible Answers :

1

Question Type : SA

Correct Marks : 4 **Wrong Marks :** 0

ଜଣେ ସତ୍ତରଣକାରୀ ନଦୀକୁ ପାରି ହେବା ପାଇଁ A ବିନ୍ଦୁରୁ B ବିନ୍ଦୁକୁ ଯିବାକୁ ଚାହୁଁଛି । ନଦୀର ସ୍ରୋତ ସହ AB ରେଖାଟି 30° କୋଣ କରୁଛି । ସତ୍ତରଣକାରୀ ଓ ନଦୀର ପରିବେଗର ପରିମାଣ ସମାନ ଅଟେ । AB ରେଖା ସହ ଅଙ୍କିତ θ କୋଣର ମୂଲ୍ୟ _____ $^\circ$ ହେବା ଉଚିତ୍ ଯେମିତିକି ସତ୍ତରଣକାରୀଟି B ବିନ୍ଦୁରେ ପହଞ୍ଚିବ ।

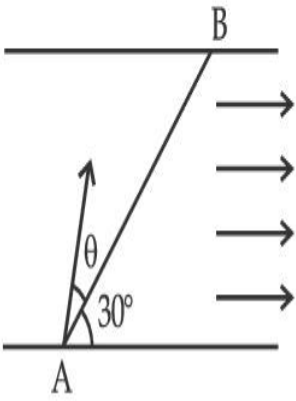

Response Type : Numeric

Evaluation Required For SA : Yes

Show Word Count : Yes

Answers Type : Equal

Text Areas : PlainText

Possible Answers :

1

Question Type : SA

Correct Marks : 4 **Wrong Marks :** 0

A particle executes simple harmonic motion represented by displacement function as

$$x(t) = A \sin(\omega t + \phi)$$

If the position and velocity of the particle at $t=0$ s are 2 cm and 2ω cm s⁻¹ respectively, then its amplitude is $x\sqrt{2}$ cm where the value of x is _____.

Response Type : Numeric

Evaluation Required For SA : Yes

Show Word Count : Yes

Answers Type : Equal

Text Areas : PlainText

Possible Answers :

1

Question Type : SA

Correct Marks : 4 **Wrong Marks :** 0

କଣିକାଟିଏ ବିସ୍ଥାପନ ଫଳନ $x(t) = A \sin(\omega t + \phi)$ ଦ୍ୱାରା ଉପସ୍ଥାପିତ ସରଳ ହାର୍ମୋନିକ୍ ଗତି ନିର୍ବାହ କରୁଅଛି । ଯଦି $t=0$ s ରେ କଣିକାଟିର ଅବସ୍ଥିତି ଓ ପରିବେଗ ଯଥାକ୍ରମେ 2 cm ଏବଂ 2ω cm s⁻¹ ହୁଏ, ତେବେ ଏହାର ଆୟାମ $x\sqrt{2}$ cm ଯେଉଁଠାରେ x ର ମୂଲ୍ୟ ହେଉଛି _____ ।

Response Type : Numeric

Evaluation Required For SA : Yes

Show Word Count : Yes

Answers Type : Equal

Text Areas : PlainText

Possible Answers :

1

Question Type : SA

Correct Marks : 4 **Wrong Marks :** 0

The difference in the number of waves when yellow light propagates through air and vacuum columns of the same thickness is one. The thickness of the air column is _____ mm.

[Refractive index of air = 1.0003, wavelength of yellow light in vacuum = 6000 Å]

Response Type : Numeric

Evaluation Required For SA : Yes

Show Word Count : Yes

Answers Type : Equal

Text Areas : PlainText

Possible Answers :

1

Question Type : SA

Correct Marks : 4 **Wrong Marks :** 0

ଯେତେବେଳେ ହଳଦିଆ ଆଲୋକ ରଶ୍ମି ଏକା ମୋଟେଇର ବାୟୁ ସ୍ତମ୍ଭ ଓ ଶୂନ୍ୟ (ଭାକ୍ୟୁମ୍) ସ୍ତମ୍ଭ ମଧ୍ୟଦେଇ ଗତି କରେ, ତରଙ୍ଗ ସଂଖ୍ୟାର ପାର୍ଥକ୍ୟ ଏକ (1) ହୁଏ । ବାୟୁ ସ୍ତମ୍ଭଟିର ମୋଟେଇ ହେଉଛି _____ mm ।

(ବାୟୁର ପ୍ରତିସରଣାଙ୍କ = 1.0003, ଶୂନ୍ୟରେ ହଳଦିଆ ଆଲୋକର ତରଙ୍ଗ ଦୈର୍ଘ୍ୟ = 6000 Å)

Response Type : Numeric

Evaluation Required For SA : Yes

Show Word Count : Yes

Answers Type : Equal

Text Areas : PlainText

Possible Answers :

1

Chemistry Section A

Section Id : 864351850

Section Number : 3

Section type : Online

Mandatory or Optional :	Mandatory
Number of Questions :	20
Number of Questions to be attempted :	20
Section Marks :	80
Enable Mark as Answered Mark for Review and Clear Response :	Yes
Sub-Section Number :	1
Sub-Section Id :	8643511077
Question Shuffling Allowed :	Yes

Question Type : MCQ Is Question Mandatory : No

Correct Marks : 4 Wrong Marks : 1

Select the correct statements.

- (A) Crystalline solids have long range order.
- (B) Crystalline solids are isotropic.
- (C) Amorphous solids are sometimes called pseudo solids.
- (D) Amorphous solids soften over a range of temperatures.
- (E) Amorphous solids have a definite heat of fusion.

Choose the most appropriate answer from the options given below :

Options :

1. (A), (C), (D) only
2. (A), (B), (E) only
3. (C), (D) only
4. (B), (D) only

Question Type : MCQ Is Question Mandatory : No

Correct Marks : 4 Wrong Marks : 1

ସଠିକ୍ ଉତ୍ତରକୁ ବାଛି :

- (A) ଦାନାଯୁକ୍ତ କଠିନରେ ଲମ୍ବା ଦୂରତାକ୍ରମ ଅଛି ।
- (B) ଦାନାଯୁକ୍ତ କଠିନ ଆଇସୋଟ୍ରପିକ୍ ଅଟନ୍ତି ।
- (C) ଦାନାହୀନ କଠିନକୁ ବେଳେବେଳେ କୁହାଯାଏ ଅବାସ୍ତବ କଠିନ ।
- (D) ଦାନାହୀନ କଠିନ ଏକ ତାପମାତ୍ରା ରେଞ୍ଜରେ ନରମ ହୁଅନ୍ତି ।
- (E) ଦାନାହୀନ କଠିନରେ ଫ୍ୟୁଜନ୍ର ଏକ ନିର୍ଦ୍ଦିଷ୍ଟ ତାପ ଅଛି ।

ନିମ୍ନ ବିକଳ୍ପ ମଧ୍ୟରୁ ସର୍ବାଧିକ ଉପଯୁକ୍ତ ଉତ୍ତରଟିକୁ ବାଛି :

Options :

1. (A), (C), (D) କେବଳ
2. (A), (B), (E) କେବଳ
3. (C), (D) କେବଳ
4. (B), (D) କେବଳ

Question Type : MCQ Is Question Mandatory : No

Correct Marks : 4 Wrong Marks : 1

If the Thompson model of the atom was correct, then the result of Rutherford's gold foil experiment would have been :

Options :

1. All of the α -particles pass through the gold foil without decrease in speed.

2. α -Particles pass through the gold foil deflected by small angles and with reduced speed.
3. α -Particles are deflected over a wide range of angles.
4. All α -particles get bounced back by 180° .

Question Type : MCQ Is Question Mandatory : No

Correct Marks : 4 Wrong Marks : 1

ଯଦି ଅମ୍ଳସମ୍ବଳ ପରମାଣୁ ମଡେଲଟି ଠିକ୍ ଥିଲା, ତାହେଲେ ରଦରଫୋର୍ଡଙ୍କ ସୁନାପାତ ପରୀକ୍ଷାର ଫଳ ହୋଇଥାନ୍ତା :

Options :

1. ସବୁତକ α -କଣିକା ବେଗ ନ ହରାଇ ସୁନାପାତ ମଧ୍ୟ ଦେଇ ଅତିକ୍ରମ କରିଯାଇଥାନ୍ତା ।
2. α -କଣିକା ବେଗ ହ୍ରାସ କରି ଛୋଟ କୋଣରେ ବିଚ୍ୟୁତି ହୋଇ ସୁନାପାତ ମଧ୍ୟ ଦେଇ ଅତିକ୍ରମ କରିଯାଇଥାନ୍ତା ।
3. α -କଣିକା ବଡ଼ କୋଣ ରେଞ୍ଜି(ଅବଧି) ରେ ବିଚ୍ୟୁତି ହୋଇଥାନ୍ତା ।
4. α -କଣିକା 180° କୋଣରେ ଲେଉଟି ଆସିଥାନ୍ତା ।

Question Type : MCQ Is Question Mandatory : No

Correct Marks : 4 Wrong Marks : 1

Given below are two statements : one is labelled as **Assertion A** and the other is labelled as **Reason R**.

Assertion A : $\text{SO}_2(\text{g})$ is adsorbed to a larger extent than $\text{H}_2(\text{g})$ on activated charcoal.

Reason R : $\text{SO}_2(\text{g})$ has a higher critical temperature than $\text{H}_2(\text{g})$.

In the light of the above statements, choose the most appropriate answer from the options given below.

Options :

1. Both **A** and **R** are correct and **R** is the correct explanation of **A**.
2. Both **A** and **R** are correct but **R** is not the correct explanation of **A**.
3. **A** is correct but **R** is not correct.
4. **A** is not correct but **R** is correct.

Question Type : MCQ Is Question Mandatory : No

Correct Marks : 4 Wrong Marks : 1

ନିମ୍ନରେ ଦୁଇଟି ଉକ୍ତି ଦିଆଯାଇଛି । ଗୋଟିଏ ଦୃଢ଼ୋକ୍ତି **A** ଏବଂ ଅନ୍ୟଟି କାରଣ **R** :

ଦୃଢ଼ୋକ୍ତି **A** : ସକ୍ରୀୟ ଚାରକୋଲ ଉପରେ $\text{H}_2(\text{g})$ ଅପେକ୍ଷା $\text{SO}_2(\text{g})$ ଅଧିକ ପରିମାଣରେ ଅବଶୋଷିତ ହୁଏ ।

କାରଣ **R** : H_2 ଅପେକ୍ଷା SO_2 ରେ ଅଧିକ କ୍ରୀଡ଼ାୟ ଚାପମାତ୍ରା ଅଛି ।

ଉପରୋକ୍ତ ଉକ୍ତି ଅନୁସାରେ, ନିମ୍ନ ବିକଳ୍ପ ମଧ୍ୟରୁ ସର୍ବାଧିକ ଉପଯୁକ୍ତ ଉତ୍ତରଟିକୁ ବାଛି ।

Options :

1. ଉଭୟ **A** ଏବଂ **R** ସଠିକ୍ ଏବଂ **A** ର ସଠିକ୍ ବ୍ୟାଖ୍ୟା ହେଉଛି **R** ।
2. ଉଭୟ **A** ଏବଂ **R** ସଠିକ୍ ଏବଂ **A** ର ସଠିକ୍ ବ୍ୟାଖ୍ୟା ନୁହେଁ **R** ।

3. A ସଠିକ୍ କିନ୍ତୁ R ସଠିକ୍ ନୁହେଁ ।

4. A ସଠିକ୍ ନୁହେଁ କିନ୍ତୁ R ସଠିକ୍ ।

Question Type : MCQ Is Question Mandatory : No

Correct Marks : 4 Wrong Marks : 1

The CORRECT order of first ionisation enthalpy is :

Options :

1. $Mg < Al < P < S$

2. $Mg < Al < S < P$

3. $Mg < S < Al < P$

4. $Al < Mg < S < P$

Question Type : MCQ Is Question Mandatory : No

Correct Marks : 4 Wrong Marks : 1

ପ୍ରଥମ ଆୟନୀକରଣ ପୂର୍ଣ୍ଣତାପର ସଠିକ୍ କ୍ରମଟି ହେଉଛି :

Options :

1. $Mg < Al < P < S$

2. $Mg < Al < S < P$

3. $Mg < S < Al < P$

4. $Al < Mg < S < P$

Question Type : MCQ Is Question Mandatory : No

Correct Marks : 4 Wrong Marks : 1

The addition of silica during the extraction of copper from its sulphide ore

Options :

1. converts copper sulphide into copper silicate
2. reduces copper sulphide into metallic copper
3. converts iron oxide into iron silicate
4. reduces the melting point of the reaction mixture

Question Type : MCQ Is Question Mandatory : No

Correct Marks : 4 Wrong Marks : 1

କପର ସଲଫାଇଡ୍ ଧାତୁପିଣ୍ଡରୁ କପର ନିସ୍କାସନ ସମୟରେ ସିଲିକା ଯୋଗ କରାଗଲେ :

Options :

1. କପର ସଲଫାଇଡ୍ କୁ କପର ସିଲିକେଟରେ ପରିଣତ କରେ ।
2. କପର ସଲଫାଇଡ୍ କୁ ମେଟାଲ କପରରେ ବିଜାରଣ କରେ ।
3. ଆଇରନ୍ ଅକ୍ସାଇଡ୍ କୁ ଆଇରନ୍ ସିଲିକେଟ୍ରେ ପରିଣତ କରେ ।
- 4.

ପ୍ରତିକ୍ରିୟା ମିଶ୍ରଣର ଗଠନାଙ୍କ ହ୍ରାସ କରେ ।

Question Type : MCQ Is Question Mandatory : No

Correct Marks : 4 Wrong Marks : 1

The number of neutrons and electrons, respectively, present in the radioactive isotope of hydrogen is :

Options :

1. 2 and 1
2. 3 and 1
3. 2 and 2
4. 1 and 1

Question Type : MCQ Is Question Mandatory : No

Correct Marks : 4 Wrong Marks : 1

ହାଇଡ୍ରୋଜେନ୍‌ର ରେଡିଓ ଆକ୍ଟିଭ୍ ଆଇସୋଟପ୍‌ରେ ନ୍ୟୁଟ୍ରନ୍ ଏବଂ ଇଲେକ୍ଟ୍ରନ୍ ସଂଖ୍ୟା ଯଥାକ୍ରମେ :

Options :

1. 2 ଏବଂ 1
2. 3 ଏବଂ 1
3. 2 ଏବଂ 2
4. 1 ଏବଂ 1

Question Type : MCQ Is Question Mandatory : No

Correct Marks : 4 Wrong Marks : 1

Match List - I with List - II :

List - I	List - II
(a) Li	(i) photoelectric cell
(b) Na	(ii) absorbent of CO ₂
(c) K	(iii) coolant in fast breeder nuclear reactor
(d) Cs	(iv) treatment of cancer
	(v) bearings for motor engines

Choose the **correct** answer from the options given below :

Options :

1. (a) - (iv), (b) - (iii), (c) - (i), (d) - (ii)
2. (a) - (v), (b) - (i), (c) - (ii), (d) - (iv)
3. (a) - (v), (b) - (ii), (c) - (iv), (d) - (i)
4. (a) - (v), (b) - (iii), (c) - (ii), (d) - (i)

Question Type : MCQ Is Question Mandatory : No

Correct Marks : 4 Wrong Marks : 1

ତାଲିକା - I ସହିତ ତାଲିକା - II କୁ ମିଳାଅ :

ତାଲିକା - I

ତାଲିକା - II

- | | |
|--------|---|
| (a) Li | (i) ଫଟୋଇଲେକ୍ଟ୍ରିକ୍ ସେଲ୍ |
| (b) Na | (ii) CO ₂ ର ଅବଶୋଷକ |
| (c) K | (iii) ଫାଷ୍ଟ ବ୍ରିଡର ନ୍ୟୁକ୍ଲିଅର ରିଏକ୍ଟରରେ ଶୀତଳକ |
| (d) Cs | (iv) କେନ୍ଦ୍ରର ଚିକିତ୍ସା |
| | (v) ମଟର ଇଞ୍ଜିନ୍ ପାଇଁ ବିୟରିଙ୍ଗ |

ନିମ୍ନ ବିକଳ୍ପ ମଧ୍ୟରୁ ସଠିକ୍ ଉତ୍ତରଟିକୁ ବାଛ :

Options :

1. (a) - (iv), (b) - (iii), (c) - (i), (d) - (ii)
2. (a) - (v), (b) - (i), (c) - (ii), (d) - (iv)
3. (a) - (v), (b) - (ii), (c) - (iv), (d) - (i)
4. (a) - (v), (b) - (iii), (c) - (ii), (d) - (i)

Question Type : MCQ Is Question Mandatory : No

Correct Marks : 4 Wrong Marks : 1

Number of Cl=O bonds in chlorous acid, chloric acid and perchloric acid respectively are :

Options :

1. 1, 1 and 3
2. 3, 1 and 1
3. 1, 2 and 3

4. 4, 1 and 0

Question Type : MCQ Is Question Mandatory : No

Correct Marks : 4 Wrong Marks : 1

କ୍ଲୋରୋସ୍ ଅମ୍ଳ, କ୍ଲୋରିକ୍ ଅମ୍ଳ ଏବଂ ପରକ୍ଲୋରିକ୍ ଅମ୍ଳରେ $Cl=O$ ବନ୍ଧ ସଂଖ୍ୟା ଯଥାକ୍ରମେ :

Options :

1. 1, 1 ଏବଂ 3

2. 3, 1 ଏବଂ 1

3. 1, 2 ଏବଂ 3

4. 4, 1 ଏବଂ 0

Question Type : MCQ Is Question Mandatory : No

Correct Marks : 4 Wrong Marks : 1

To an aqueous solution containing ions such as Al^{3+} , Zn^{2+} , Ca^{2+} , Fe^{3+} , Ni^{2+} , Ba^{2+} and Cu^{2+} was added conc. HCl, followed by H_2S .

The total number of cations precipitated during this reaction is/are :

Options :

1. 3

2. 2

3. 1

4. 4

Question Type : MCQ Is Question Mandatory : No

Correct Marks : 4 Wrong Marks : 1

Al^{3+} , Zn^{2+} , Ca^{2+} , Fe^{3+} , Ni^{2+} , Ba^{2+} ଏବଂ Cu^{2+} ଆୟନ ଧାରଣ କରୁଥିବା ଏକ ଜଳୀୟ ଦ୍ରବଣରେ ଗାଢ଼ HCl ମିଶାଯିବା ପରେ ପରେ H_2S ପ୍ରବାହିତ କରାଗଲା । ଏହି ପ୍ରତିକ୍ରିୟାରେ ସମସ୍ତ ଅବକ୍ଷେପିତ କେତାୟନ୍ ସଂଖ୍ୟା ହେଉଛି :

Options :

1. 3

2. 2

3. 1

4. 4

Question Type : MCQ Is Question Mandatory : No

Correct Marks : 4 Wrong Marks : 1

Given below are two statements :

Statement I : $[Mn(CN)_6]^{3-}$, $[Fe(CN)_6]^{3-}$ and $[Co(C_2O_4)_3]^{3-}$ are d^2sp^3 hybridised.

Statement II : $[MnCl_6]^{3-}$ and $[FeF_6]^{3-}$ are paramagnetic and have 4 and 5 unpaired electrons, respectively.

In the light of the above statements, choose the **correct** answer from the options given below :

Options :

1. Both **statement I** and **statement II** are true

2. Both statement I and statement II are false
3. Statement I is correct but statement II is false
4. Statement I is incorrect but statement II is true

Question Type : MCQ Is Question Mandatory : No

Correct Marks : 4 Wrong Marks : 1

ନିମ୍ନରେ ଦୁଇଟି ଉକ୍ତି ଦିଆଯାଇଛି :

ଉକ୍ତି I : $[\text{Mn}(\text{CN})_6]^{3-}$, $[\text{Fe}(\text{CN})_6]^{3-}$ ଏବଂ $[\text{Co}(\text{C}_2\text{O}_4)_3]^{3-}$ ଗୁଡ଼ିକ d^2sp^3 ଶଙ୍କରୀକୃତ ।

ଉକ୍ତି II : $[\text{MnCl}_6]^{3-}$ ଏବଂ $[\text{FeF}_6]^{3-}$ ଅନୁରୂପକାୟ ଅଟନ୍ତି ଏବଂ ଏଥିରେ ଯଥାକ୍ରମେ 4 ଏବଂ 5 ଅଯୋଡ଼ା ଇଲେକ୍ଟ୍ରନ୍ ଅଛନ୍ତି ।

ଉପରୋକ୍ତ ଉକ୍ତି ଅନୁସାରେ, ନିମ୍ନ ବିକଳ୍ପ ମଧ୍ୟରୁ ସଠିକ୍ ଉତ୍ତରଟିକୁ ବାଛି :

Options :

1. ଉଭୟ ଉକ୍ତି I ଏବଂ II ସତ୍ୟ ଅଟେ ।
2. ଉଭୟ ଉକ୍ତି I ଏବଂ II ମିଥ୍ୟା ଅଟେ ।
3. ଉକ୍ତି I ସତ୍ୟ କିନ୍ତୁ ଉକ୍ତି II ମିଥ୍ୟା ଅଟେ ।
4. ଉକ୍ତି I ମିଥ୍ୟା କିନ୍ତୁ ଉକ୍ତି II ସତ୍ୟ ଅଟେ ।

Question Type : MCQ Is Question Mandatory : No

Correct Marks : 4 Wrong Marks : 1

Match List - I with List - II :

List - I (compound)	List - II (effect/affected species)
(a) Carbon monoxide	(i) Carcinogenic
(b) Sulphur dioxide	(ii) Metabolized by pyrus plants
(c) Polychlorinated biphenyls	(iii) Haemoglobin
(d) Oxides of nitrogen	(iv) Stiffness of flower buds

Choose the **correct** answer from the options given below :

Options :

1. (a) - (iii), (b) - (iv), (c) - (i), (d) - (ii)
2. (a) - (iii), (b) - (iv), (c) - (ii), (d) - (i)
3. (a) - (iv), (b) - (i), (c) - (iii), (d) - (ii)
4. (a) - (i), (b) - (ii), (c) - (iii), (d) - (iv)

Question Type : MCQ Is Question Mandatory : No

Correct Marks : 4 Wrong Marks : 1

ତାଲିକା - I ସହିତ ତାଲିକା - II କୁ ମିଳାଅ :

ତାଲିକା - I

ଯୌଗିକ

- (a) କାରବନ୍ ମନୋକ୍ସାଇଡ୍
- (b) ସଲଫର ଡାଇଅକ୍ସାଇଡ୍
- (c) ପଲିକ୍ଲୋରିନେଟେଡ୍ ବାଇଫିନାଇଲସ୍
- (d) ନାଇଟ୍ରୋଜେନ୍ ଅକ୍ସାଇଡ୍

ତାଲିକା - II

ପ୍ରଭାବ/ପ୍ରଭାବିତ ପ୍ରକାରି

- (i) କାର୍ବିନୋଜେନିକ୍
- (ii) ପାଇରସ ବୃକ୍ଷ ଦ୍ୱାରା ଉପପଚିତ
- (iii) ହିମୋଗ୍ଲୋବିନ୍
- (iv) ଫୁଲ କଢର ଦୃଢ଼ିକରଣ

ନିମ୍ନ ବିକଳ୍ପ ମଧ୍ୟରୁ ସଠିକ୍ ଉତ୍ତରଟିକୁ ବାଛ :

Options :

1. (a) - (iii), (b) - (iv), (c) - (i), (d) - (ii)
2. (a) - (iii), (b) - (iv), (c) - (ii), (d) - (i)
3. (a) - (iv), (b) - (i), (c) - (iii), (d) - (ii)
4. (a) - (i), (b) - (ii), (c) - (iii), (d) - (iv)

Question Type : MCQ Is Question Mandatory : No

Correct Marks : 4 Wrong Marks : 1

Which one of the following set of elements can be detected using sodium fusion extract ?

Options :

1. Nitrogen, Phosphorous, Carbon, Sulfur
2. Sulfur, Nitrogen, Phosphorous, Halogens
3. Phosphorous, Oxygen, Nitrogen, Halogens

4. Halogens, Nitrogen, Oxygen, Sulfur

Question Type : MCQ Is Question Mandatory : No

Correct Marks : 4 Wrong Marks : 1

ସେଡ଼ିଅମ୍ ଫ୍ଲୁଇନ୍ ଏକ୍ସଟ୍ରାକୁ ବ୍ୟବହାର କରି ମୌଳିକ ମାନକର କେଉଁ ସମାହାରଟି ଚିହ୍ନାୟାଜପାରିବ ?

Options :

1. ନାଇଟ୍ରୋଜେନ, ଫସ୍ଫରସ୍, କାର୍ବନ୍, ସଲ୍ଫର
2. ସଲ୍ଫର, ନାଇଟ୍ରୋଜେନ, ଫସ୍ଫରସ୍, ହାଲୋଜେନ୍ସ୍
3. ଫସ୍ଫରସ୍, ଅକ୍ସିଜେନ, ନାଇଟ୍ରୋଜେନ, ହାଲୋଜେନ୍ସ୍
4. ହାଲୋଜେନ୍ସ୍, ନାଇଟ୍ରୋଜେନ, ଅକ୍ସିଜେନ, ସଲ୍ଫର

Question Type : MCQ Is Question Mandatory : No

Correct Marks : 4 Wrong Marks : 1

Given below are two statements :

Statement I : Hyperconjugation is a permanent effect.

Statement II : Hyperconjugation in ethyl cation $(\text{CH}_3 - \overset{+}{\text{C}}\text{H}_2)$ involves the overlapping of $\text{C}_{\text{sp}^2} - \text{H}_{1s}$ bond with empty 2p orbital of other carbon.

Choose the correct option :

Options :

1. Both **statement I** and **statement II** are true
2. Both **statement I** and **statement II** are false
3. **Statement I** is correct but **statement II** is false
4. **Statement I** is incorrect but **statement II** is true

Question Type : MCQ Is Question Mandatory : No

Correct Marks : 4 Wrong Marks : 1

ନିମ୍ନରେ ଦୁଇଟି ଉକ୍ତି ଦିଆଯାଇଛି ।

ଉକ୍ତି I : ହାଇପର କଞ୍ଜୁରେସନ୍ ଏକ ଚିରସ୍ଥାୟୀ ପ୍ରଭାବ ।

ଉକ୍ତି II : ଇଥାଇଲ୍ କେଟାୟନ୍ ($\text{CH}_3 - \overset{+}{\text{C}}\text{H}_2$) ରେ $\text{C}_{sp^2} - \text{H}_{1s}$ ବନ୍ଧ ସହିତ ଅନ୍ୟ କାରବନ୍ ପରମାଣୁର ଶୂନ୍ୟ 2p ଅରବିଟାଲର ଅଧିକ୍ରମଣ ଅନ୍ତର୍ଭୁକ୍ତ ।

ସଠିକ୍ ବିକଳ୍ପଟିକୁ ବାଛି :

Options :

1. ଉଭୟ **ଉକ୍ତି I** ଏବଂ **ଉକ୍ତି II** ସତ୍ୟ ଅଟେ ।
2. ଉଭୟ **ଉକ୍ତି I** ଏବଂ **ଉକ୍ତି II** ମିଥ୍ୟା ଅଟେ ।
3. **ଉକ୍ତି I** ସତ୍ୟ ଏବଂ **ଉକ୍ତି II** ମିଥ୍ୟା ଅଟେ ।
4. **ଉକ୍ତି I** ମିଥ୍ୟା ଏବଂ **ଉକ୍ତି II** ସତ୍ୟ ଅଟେ ।

Question Type : MCQ Is Question Mandatory : No

Correct Marks : 4 Wrong Marks : 1

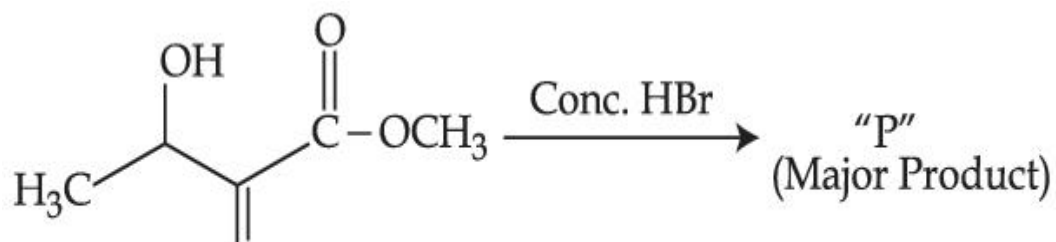

Consider the above reaction, the major product "P" formed is :

Options :

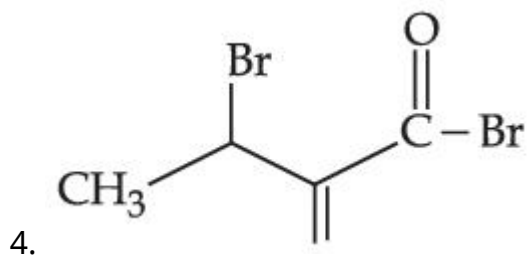
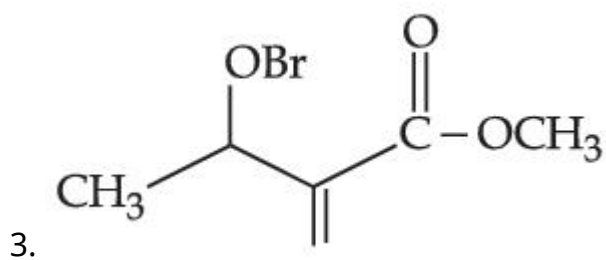
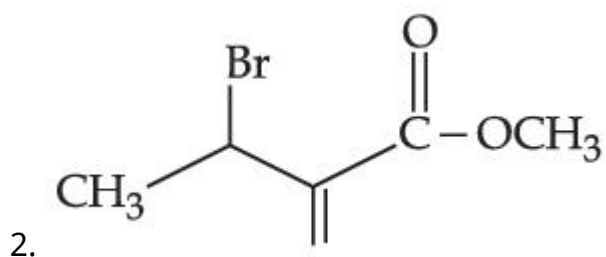
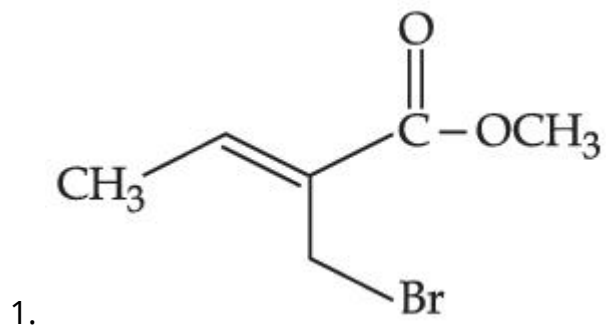

Question Type : MCQ Is Question Mandatory : No

Correct Marks : 4 Wrong Marks : 1

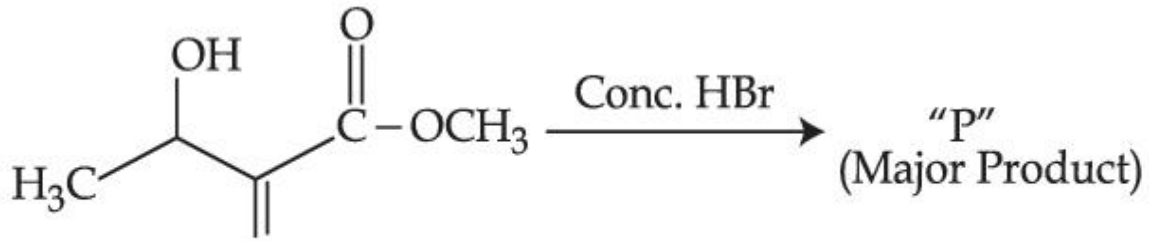

ଉପରୋକ୍ତ ପ୍ରତିକ୍ରିୟାଟିକୁ ବିଚାର କର । ଗଠିତ ମୁଖ୍ୟ ଉତ୍ପାଦଟି “P” ହେଉଛି :

Options :

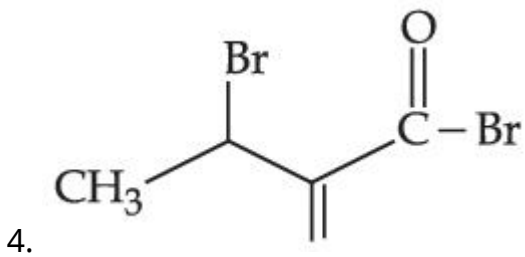
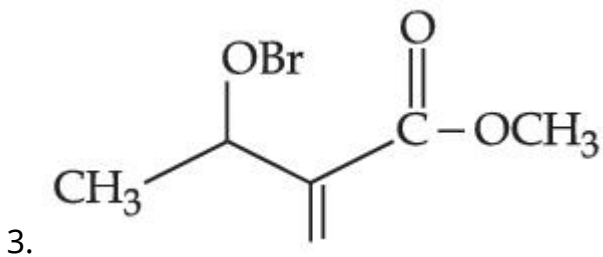
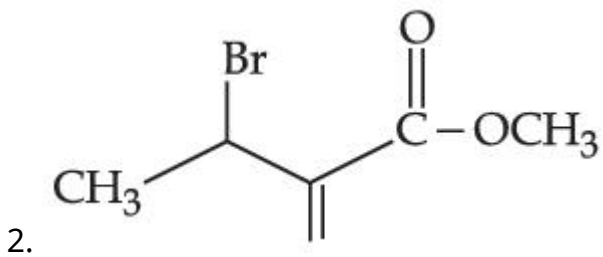
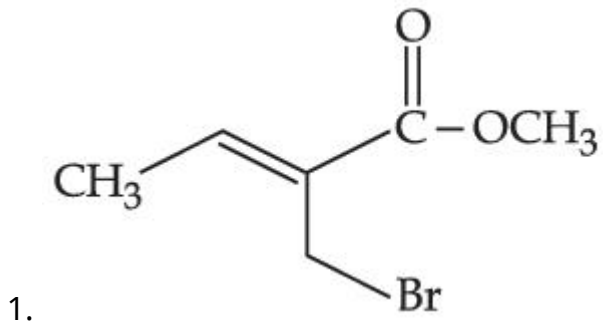

Question Type : MCQ Is Question Mandatory : No

Correct Marks : 4 Wrong Marks : 1

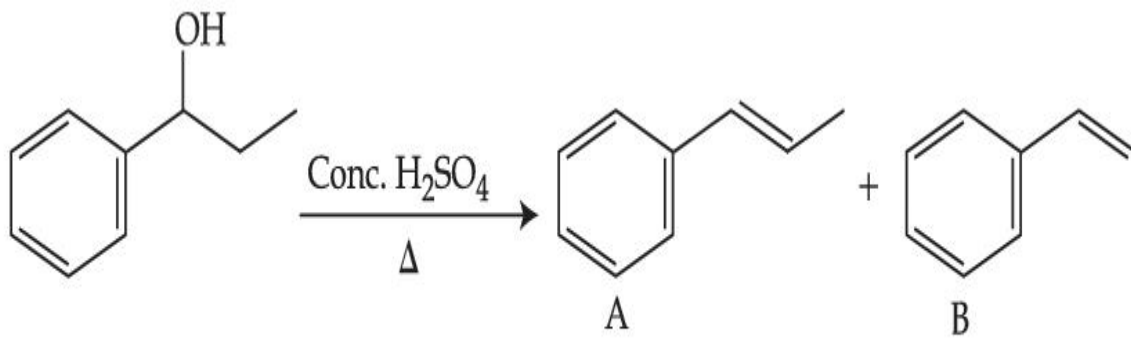

Consider the above reaction, and choose the correct statement :

Options :

1. Compound **A** will be the major product
2. Compound **B** will be the major product
3. Both compounds **A** and **B** are formed equally
4. The reaction is not possible in acidic medium

Question Type : MCQ Is Question Mandatory : No

Correct Marks : 4 Wrong Marks : 1

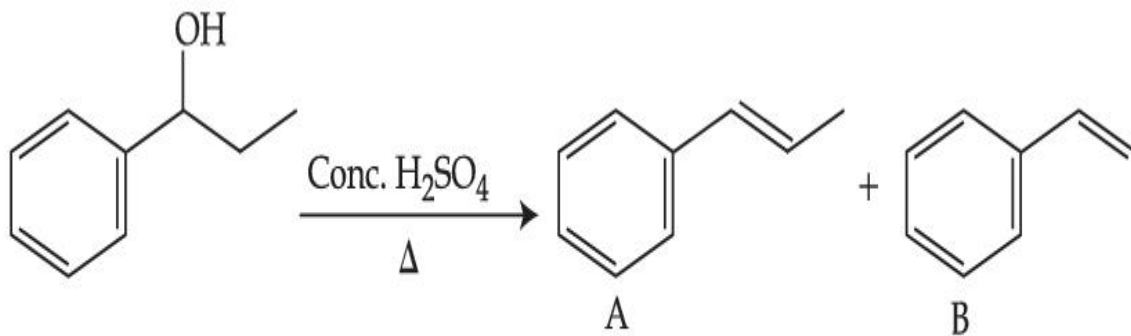

ଉପରୋକ୍ତ ପ୍ରତିକ୍ରିୟାଟିକୁ ବିଚାର କର ଏବଂ ସଠିକ୍ ଉତ୍ତର ଚିହ୍ନଟି ବାଛି :

Options :

1. ଯୌଗିକ **A** ମୁଖ୍ୟ ଉତ୍ପାଦ ହେବ ।
2. ଯୌଗିକ **B** ମୁଖ୍ୟ ଉତ୍ପାଦ ହେବ ।

3. ଉଭୟ A ଏବଂ B ଯୌଗିକ ସମାନ ଭାବେ ଗଠନ ହୁଅନ୍ତି ।
4. ଅମ୍ଳୀୟ ମାଧ୍ୟମରେ ପ୍ରତିକ୍ରିୟାଟି ସମ୍ଭବ ନୁହେଁ ।

Question Type : MCQ Is Question Mandatory : No

Correct Marks : 4 Wrong Marks : 1



Consider the above reaction and identify "Y".

Options :

1. $-\text{COOH}$
2. $-\text{CH}_2\text{NH}_2$
3. $-\text{CHO}$
4. $-\text{CONH}_2$

Question Type : MCQ Is Question Mandatory : No

Correct Marks : 4 Wrong Marks : 1



ଉପରୋକ୍ତ ପ୍ରତିକ୍ରିୟାଟିକୁ ବିଚାର କର ଏବଂ "Y" କୁ ଚିହ୍ନଟାଅ :

Options :

1. $-\text{COOH}$
2. $-\text{CH}_2\text{NH}_2$
3. $-\text{CHO}$
4. $-\text{CONH}_2$

Question Type : MCQ Is Question Mandatory : No

Correct Marks : 4 Wrong Marks : 1

The correct sequence of correct reagents for the following transformation is :

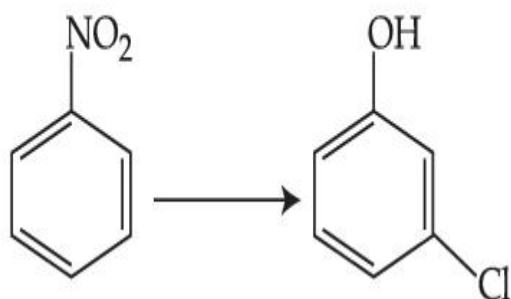

Options :

1. (i) $\text{Cl}_2, \text{FeCl}_3$ (ii) Fe, HCl (iii) $\text{NaNO}_2, \text{HCl}, 0^\circ\text{C}$ (iv) $\text{H}_2\text{O}/\text{H}^+$
2. (i) Fe, HCl (ii) $\text{NaNO}_2, \text{HCl}, 0^\circ\text{C}$ (iii) $\text{H}_2\text{O}/\text{H}^+$ (iv) $\text{Cl}_2, \text{FeCl}_3$
3. (i) Fe, HCl (ii) Cl_2, HCl (iii) $\text{NaNO}_2, \text{HCl}, 0^\circ\text{C}$ (iv) $\text{H}_2\text{O}/\text{H}^+$
4. (i) $\text{Cl}_2, \text{FeCl}_3$ (ii) $\text{NaNO}_2, \text{HCl}, 0^\circ\text{C}$ (iii) Fe, HCl (iv) $\text{H}_2\text{O}/\text{H}^+$

Question Type : MCQ Is Question Mandatory : No

Correct Marks : 4 Wrong Marks : 1

ନିମ୍ନ ରୂପାନ୍ତରରେ ସଠିକ୍ ଅଭିକର୍ଷକ ଗୁଡ଼ିକର ସଠିକ୍ କ୍ରମଟି ହେଉଛି :

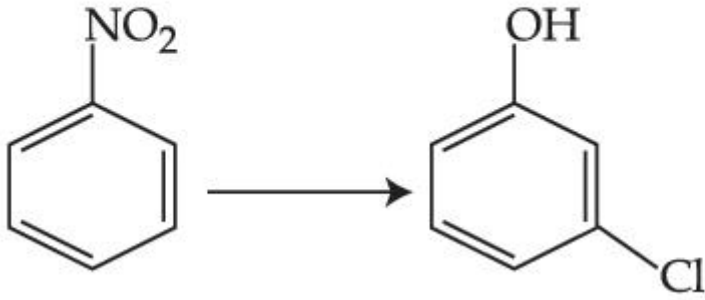

Options :

1. (i) $\text{Cl}_2, \text{FeCl}_3$ (ii) Fe, HCl (iii) $\text{NaNO}_2, \text{HCl}, 0^\circ\text{C}$ (iv) $\text{H}_2\text{O}/\text{H}^+$
2. (i) Fe, HCl (ii) $\text{NaNO}_2, \text{HCl}, 0^\circ\text{C}$ (iii) $\text{H}_2\text{O}/\text{H}^+$ (iv) $\text{Cl}_2, \text{FeCl}_3$
3. (i) Fe, HCl (ii) Cl_2, HCl (iii) $\text{NaNO}_2, \text{HCl}, 0^\circ\text{C}$ (iv) $\text{H}_2\text{O}/\text{H}^+$
4. (i) $\text{Cl}_2, \text{FeCl}_3$ (ii) $\text{NaNO}_2, \text{HCl}, 0^\circ\text{C}$ (iii) Fe, HCl (iv) $\text{H}_2\text{O}/\text{H}^+$

Question Type : MCQ Is Question Mandatory : No

Correct Marks : 4 Wrong Marks : 1

What is A in the following reaction ?

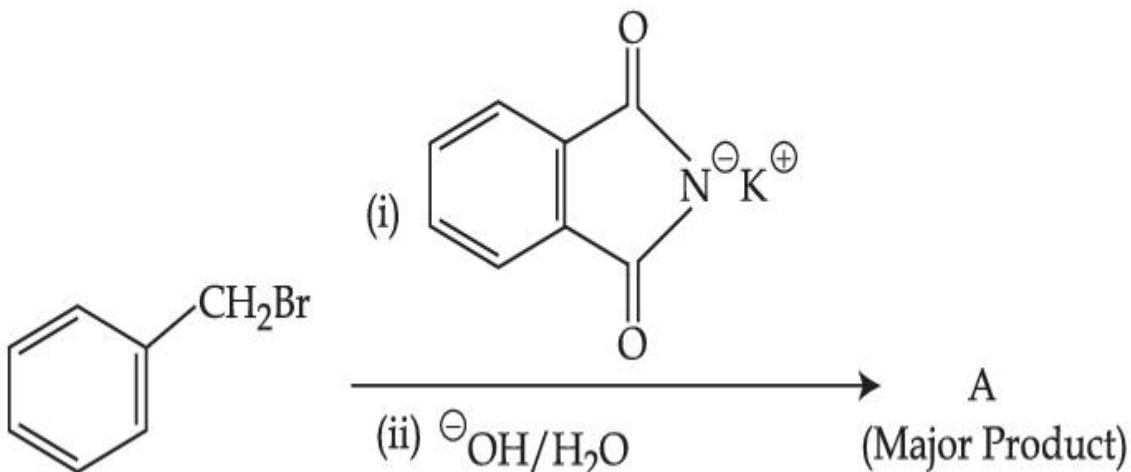

Options :

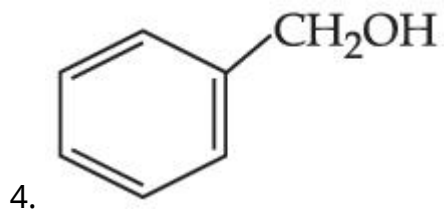
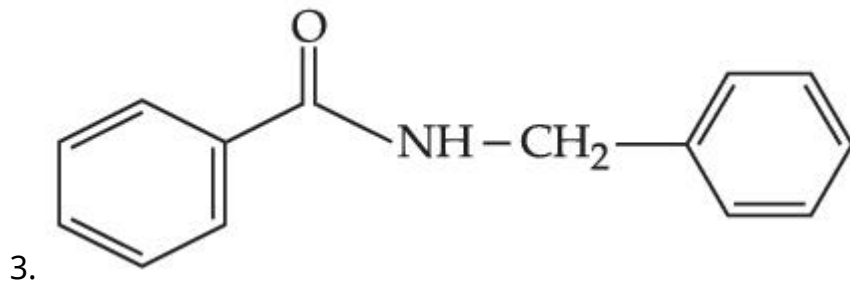
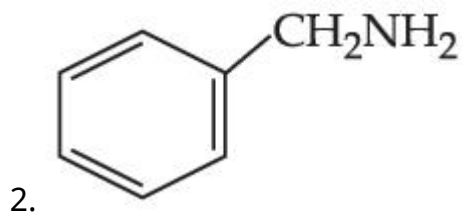
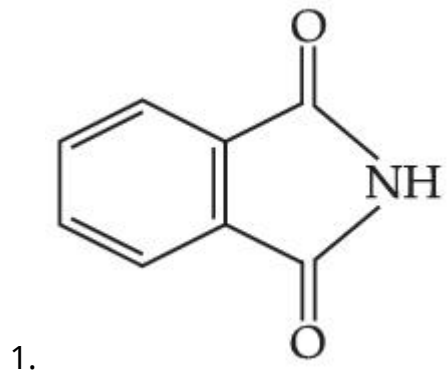

Question Type : MCQ Is Question Mandatory : No

Correct Marks : 4 Wrong Marks : 1

ନିମ୍ନ ପ୍ରତିକ୍ରିୟାଟିରେ 'A' କଣ ?

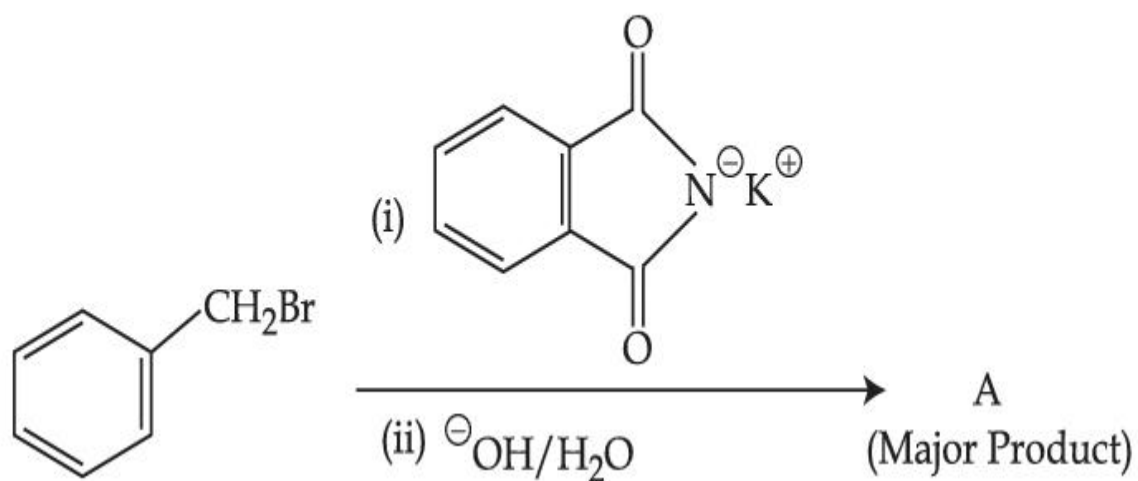

Options :

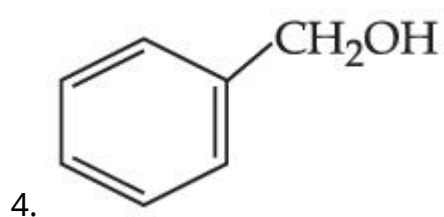
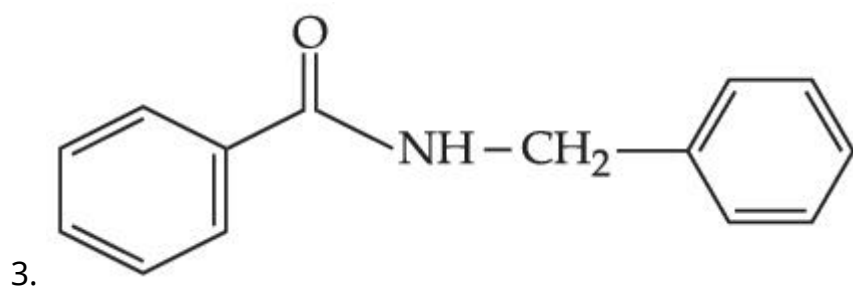
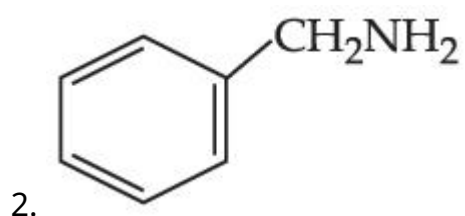
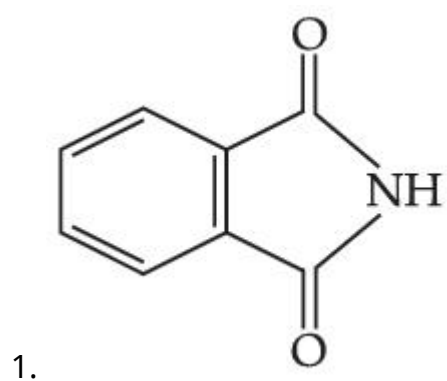

Question Type : MCQ Is Question Mandatory : No

Correct Marks : 4 Wrong Marks : 1

Given below are two statements :

Statement I : Penicillin is a bacteriostatic type antibiotic.

Statement II : The general structure of Penicillin is :

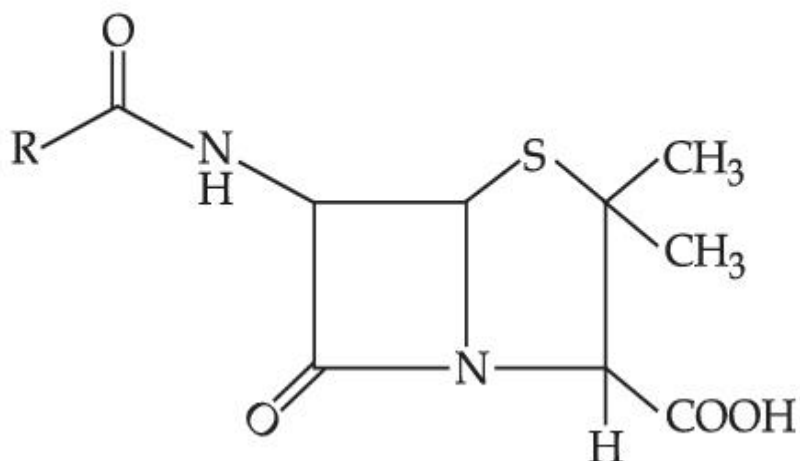

Choose the correct option :

Options :

1. Both **statement I** and **statement II** are true
2. Both **statement I** and **statement II** are false
3. **Statement I** is correct but **statement II** is false
4. **Statement I** is incorrect but **statement II** is true

Question Type : MCQ Is Question Mandatory : No

Correct Marks : 4 Wrong Marks : 1

ନିମ୍ନରେ ଦୁଇଟି ଉକ୍ତି ଦିଆଯାଇଛି :

ଉକ୍ତି I : ପେନ୍‌ସିଲିନ୍ ଏକ ସ୍ଥିର ବୀଜାଣୁ ପ୍ରକାରର ପ୍ରତିଜୈବିକ ।

ଉକ୍ତି II : ପେନ୍‌ସିଲିନ୍‌ର ସଂରଚନା ହେଉଛି :

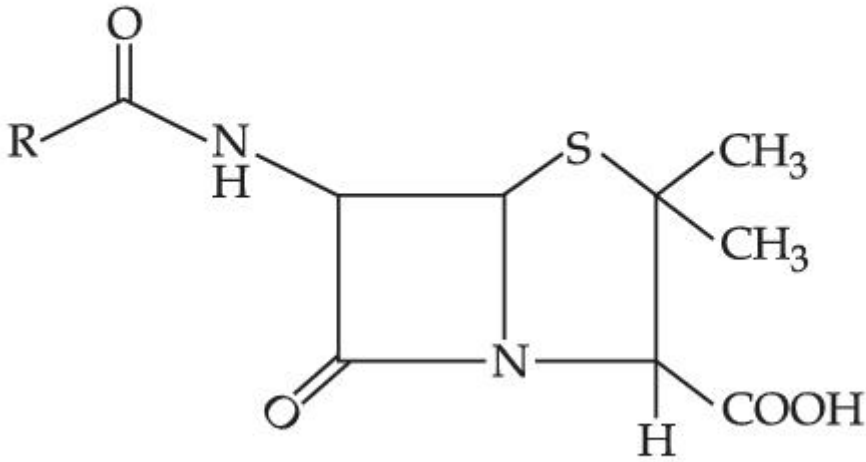

ସଠିକ୍ ବିକଳ୍ପଟିକୁ ବାଛି :

Options :

1. ଉଭୟ ଉକ୍ତି I ଏବଂ ଉକ୍ତି II ସତ୍ୟ ଅଟେ ।
2. ଉଭୟ ଉକ୍ତି I ଏବଂ ଉକ୍ତି II ସତ୍ୟ ଅଟେ ।
3. ଉକ୍ତି I ସତ୍ୟ କିନ୍ତୁ ଉକ୍ତି II ମିଥ୍ୟା ଅଟେ ।
4. ଉକ୍ତି I ମିଥ୍ୟା କିନ୍ତୁ ଉକ୍ତି II ସତ୍ୟ ଅଟେ ।

Question Type : MCQ Is Question Mandatory : No

Correct Marks : 4 Wrong Marks : 1

Compound A gives D-Galactose and D-Glucose on hydrolysis. The compound A is :

Options :

1. Maltose
2. Lactose

3. Sucrose

4. Amylose

Question Type : MCQ Is Question Mandatory : No

Correct Marks : 4 Wrong Marks : 1

ଜଳ ବିଘଟନ ଦ୍ୱାରା ଯୌଗିକ A ଦିଏ D ଗାଲାଇକୋଜ୍ ଏବଂ D ଗ୍ଲୁକୋଜ୍ । ଯୌଗିକ A ଚି ହେଉଛି :

Options :

1. ମାଲଟୋଜ୍

2. ଲାକ୍ଟୋଜ୍

3. ସୁକ୍ରୋଜ୍

4. ଆମାଇଲୋଜ୍

Chemistry Section B

Section Id :	864351851
Section Number :	4
Section type :	Online
Mandatory or Optional :	Mandatory
Number of Questions :	10
Number of Questions to be attempted :	5
Section Marks :	20

Enable Mark as Answered Mark for Review and

Yes

Clear Response :

Sub-Section Number :

1

Sub-Section Id :

8643511078

Question Shuffling Allowed :

Yes

Question Type : SA

Correct Marks : 4 Wrong Marks : 0

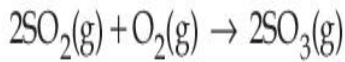

The above reaction is carried out in a vessel starting with partial pressures $P_{\text{SO}_2} = 250$ m bar, $P_{\text{O}_2} = 750$ m bar and $P_{\text{SO}_3} = 0$ bar. When the reaction is complete, the total pressure in the reaction vessel is _____ m bar. (Round off to the Nearest Integer).

Response Type : Numeric

Evaluation Required For SA : Yes

Show Word Count : Yes

Answers Type : Equal

Text Areas : PlainText

Possible Answers :

1

Question Type : SA

Correct Marks : 4 Wrong Marks : 0

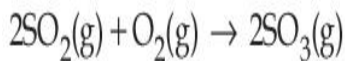

ଆଂଶିକ ଚାପ $P_{\text{SO}_2} = 250$ m bar, $P_{\text{O}_2} = 750$ m bar ଏବଂ $P_{\text{SO}_3} = 0$ bar ସହିତ ଉପର ପ୍ରତିକ୍ରିୟାଟି ଏକ ପାତ୍ରରେ ଆରମ୍ଭ କରାଗଲା । ପ୍ରତିକ୍ରିୟାଟି ଯେତେବେଳେ ସମ୍ପୂର୍ଣ୍ଣ ହୁଏ, ପ୍ରତିକ୍ରିୟା ପାତ୍ରରେ ମୋଟ ଚାପ ହେଉଛି _____ m bar ।

(ନିକଟତମ ପୂର୍ଣ୍ଣସଂଖ୍ୟାରେ ପରିଣତ କର)

Response Type : Numeric

Evaluation Required For SA : Yes

Show Word Count : Yes

Answers Type : Equal

Text Areas : PlainText

Possible Answers :

1

Question Type : SA

Correct Marks : 4 Wrong Marks : 0

The total number of electrons in all bonding molecular orbitals of O_2^{2-} is _____.

(Round off to the Nearest Integer).

Response Type : Numeric

Evaluation Required For SA : Yes

Show Word Count : Yes

Answers Type : Equal

Text Areas : PlainText

Possible Answers :

1

Question Type : SA

Correct Marks : 4 Wrong Marks : 0

O_2^{2-} ର ସମସ୍ତ ବନ୍ଧିତ ଆଣବିକ ଅରବିତାଳରେ ମୋଟ ଇଲେକ୍ଟ୍ରନ୍ ସଂଖ୍ୟା ହେଉଛି _____ ।

(ନିକଟତମ ପୂର୍ଣ୍ଣସଂଖ୍ୟାରେ ପରିଣତ କର)

Response Type : Numeric

Evaluation Required For SA : Yes

Show Word Count : Yes

Answers Type : Equal

Text Areas : PlainText

Possible Answers :

1

Question Type : SA**Correct Marks : 4 Wrong Marks : 0**

When 400 mL of 0.2 M H_2SO_4 solution is mixed with 600 mL of 0.1 M NaOH solution, the increase in temperature of the final solution is _____ $\times 10^{-2}$ K. (Round off to the Nearest Integer).

[Use : $\text{H}^+(\text{aq}) + \text{OH}^-(\text{aq}) \rightarrow \text{H}_2\text{O} : \Delta_r H = -57.1 \text{ kJ mol}^{-1}$

Specific heat of $\text{H}_2\text{O} = 4.18 \text{ J K}^{-1} \text{ g}^{-1}$

density of $\text{H}_2\text{O} = 1.0 \text{ g cm}^{-3}$

Assume no change in volume of solution on mixing.]

Response Type : Numeric**Evaluation Required For SA : Yes****Show Word Count : Yes****Answers Type : Equal****Text Areas : PlainText****Possible Answers :****1****Question Type : SA****Correct Marks : 4 Wrong Marks : 0**

ଯେତେବେଳେ 600 mL ର 0.1 M NaOH ଦ୍ରବଣ ସହିତ 400 mL ର 0.2 M H_2SO_4 ଦ୍ରବଣ ମିଶାଯାଏ, ଅନ୍ତିମ ଦ୍ରବଣର ବର୍ଦ୍ଧିତ ତାପମାତ୍ରା ହେଉଛି _____ $\times 10^{-2}$ K ।

(ନିକଟତମ ପୂର୍ଣ୍ଣସଂଖ୍ୟାରେ ପରିଣତ କର)

ବ୍ୟବହାର କର : $\text{H}^+(\text{aq}) + \text{OH}^-(\text{aq}) \rightarrow \text{H}_2\text{O} : \Delta_r H = -57.1 \text{ kJ mol}^{-1}$

ଜଳର ବିଶିଷ୍ଟ ତାପ $\text{H}_2\text{O} = 4.18 \text{ J K}^{-1} \text{ g}^{-1}$

ଜଳର ସାନ୍ଦ୍ରତା $\text{H}_2\text{O} = 1.0 \text{ g cm}^{-3}$

(ଗ୍ରହଣ କର ମିଶ୍ରଣ ଦ୍ୱାରା ଆୟତନର କୌଣସି ପରିବର୍ତ୍ତନ ହୁଏ ନାହିଁ)

Response Type : Numeric

Evaluation Required For SA : Yes

Show Word Count : Yes

Answers Type : Equal

Text Areas : PlainText

Possible Answers :

1

Question Type : SA

Correct Marks : 4 Wrong Marks : 0

In a solvent 50% of an acid HA dimerizes and the rest dissociates. The van't Hoff factor of the acid is _____ $\times 10^{-2}$. (Round off to the Nearest Integer).

Response Type : Numeric

Evaluation Required For SA : Yes

Show Word Count : Yes

Answers Type : Equal

Text Areas : PlainText

Possible Answers :

1

Question Type : SA

Correct Marks : 4 Wrong Marks : 0

HA ଅମ୍ଳ ଏକ ଦ୍ରାବକରେ 50% ଡାଇମେରାଇଜ୍ କରେ ଏବଂ ଅବଶିଷ୍ଟାଂଶ ଅଣୁ ପୃଥକୀକରଣ କରନ୍ତି । ଅମ୍ଳର ଭେଣ୍ଟହଫ୍ କାରକ ହେଉଛି _____ $\times 10^{-2}$ ।

(ନିକଟତମ ପୂର୍ଣ୍ଣସଂଖ୍ୟାରେ ପରିଣତ କର)

Response Type : Numeric

Evaluation Required For SA : Yes

Show Word Count : Yes

Answers Type : Equal

Text Areas : PlainText

Possible Answers :

1

Question Type : SA

Correct Marks : 4 Wrong Marks : 0

The equilibrium constant for the reaction

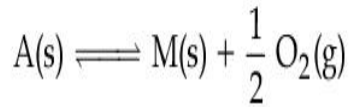

is $K_p = 4$. At equilibrium, the partial pressure of O_2 is _____ atm. (Round off to the Nearest Integer).

Response Type : Numeric

Evaluation Required For SA : Yes

Show Word Count : Yes

Answers Type : Equal

Text Areas : PlainText

Possible Answers :

1

Question Type : SA

Correct Marks : 4 Wrong Marks : 0

ପ୍ରତିକ୍ରିୟା $A(s) \rightleftharpoons M(s) + \frac{1}{2} O_2(g)$ ର ସାମ୍ୟ ସ୍ଥିରାଙ୍କ $K_p = 4$ ସାମ୍ୟାବସ୍ଥାରେ ଅକ୍ସିଜେନ୍‌ର ଆଂଶିକ ଚାପ ହେଉଛି

_____ atm ।

(ନିକଟତମ ପୂର୍ଣ୍ଣସଂଖ୍ୟାରେ ପରିଣତ କର)

Response Type : Numeric

Evaluation Required For SA : Yes

Show Word Count : Yes

Answers Type : Equal

Text Areas : PlainText

Possible Answers :

1

Question Type : SA

Correct Marks : 4 Wrong Marks : 0

For the cell $\text{Cu(s)}|\text{Cu}^{2+}(\text{aq}) (0.1\text{ M})||\text{Ag}^+(\text{aq}) (0.01\text{ M})|\text{Ag(s)}$

the cell potential $E_1 = 0.3095\text{ V}$

For the cell $\text{Cu(s)}|\text{Cu}^{2+}(\text{aq}) (0.01\text{ M})||\text{Ag}^+(\text{aq}) (0.001\text{ M})|\text{Ag(s)}$

the cell potential = _____ $\times 10^{-2}\text{ V}$. (Round off to the Nearest Integer).

[Use : $\frac{2.303\text{ RT}}{\text{F}} = 0.059$]

Response Type : Numeric

Evaluation Required For SA : Yes

Show Word Count : Yes

Answers Type : Equal

Text Areas : PlainText

Possible Answers :

1

Question Type : SA

Correct Marks : 4 Wrong Marks : 0

$\text{Cu(s)}|\text{Cu}^{2+}(\text{aq}) (0.1\text{M})||\text{Ag}^+(\text{aq}) (0.01\text{M})|\text{Ag(s)}$ କୋଷଟି ପାଇଁ

ଇଲେକ୍ଟ୍ରୋଡ୍ ବିଭବ $E_1 = 0.3095\text{ V}$

$\text{Cu(s)}|\text{Cu}^{2+}(\text{aq}) (0.01\text{M})||\text{Ag}^+(\text{aq}) (0.001\text{M})|\text{Ag(s)}$ କୋଷଟି ପାଇଁ

ଇଲେକ୍ଟ୍ରୋଡ୍ ବିଭବ ହେଉଛି = _____ $\times 10^{-2}\text{ V}$ ।

(ନିକଟତମ ପୂର୍ଣ୍ଣସଂଖ୍ୟାରେ ପରିଣତ କର)

(ବ୍ୟବହାର କର : $\frac{2.303 RT}{F} = 0.059$)

Response Type : Numeric

Evaluation Required For SA : Yes

Show Word Count : Yes

Answers Type : Equal

Text Areas : PlainText

Possible Answers :

1

Question Type : SA

Correct Marks : 4 **Wrong Marks :** 0

For the first order reaction $A \rightarrow 2B$, 1 mole of reactant A gives 0.2 moles of B after 100 minutes. The half life of the reaction is _____ min. (Round off to the Nearest Integer).

[Use : $\ln 2 = 0.69$, $\ln 10 = 2.3$

Properties of logarithms : $\ln x^y = y \ln x$;

$$\ln\left(\frac{x}{y}\right) = \ln x - \ln y]$$

Response Type : Numeric

Evaluation Required For SA : Yes

Show Word Count : Yes

Answers Type : Equal

Text Areas : PlainText

Possible Answers :

1

Question Type : SA

Correct Marks : 4 Wrong Marks : 0

ଏକ ପ୍ରଥମ କ୍ରମ ପ୍ରତିକ୍ରିୟା $A \rightarrow 2B$ ର 100 ମିନିଟ୍ ପରେ 1 ମୋଲ୍ ପ୍ରତିକାରକ A, 0.2 ମୋଲ B ଦିଏ । ପ୍ରତିକ୍ରିୟାର ଅର୍ଦ୍ଧ-ଜୀବକାଳ _____ min ।

(ନିକଟତମ ପୂର୍ଣ୍ଣସଂଖ୍ୟାରେ ପରିଣତ କର)

ବ୍ୟବହାର କର : $\ln 2 = 0.69$, $\ln 10 = 2.3$, ଲଗାରିଦମ୍‌ର ଗୁଣ $\ln x^y = y \ln x$;

$$\ln\left(\frac{x}{y}\right) = \ln x - \ln y]$$

Response Type : Numeric

Evaluation Required For SA : Yes

Show Word Count : Yes

Answers Type : Equal

Text Areas : PlainText

Possible Answers :

1

Question Type : SA

Correct Marks : 4 Wrong Marks : 0

3 moles of metal complex with formula $\text{Co(en)}_2\text{Cl}_3$ gives 3 moles of silver chloride on treatment with excess of silver nitrate. The secondary valency of Co in the complex is _____.
(Round off to the Nearest Integer).

Response Type : Numeric

Evaluation Required For SA : Yes

Show Word Count : Yes

Answers Type : Equal

Text Areas : PlainText

Possible Answers :

1

Question Type : SA

Correct Marks : 4 Wrong Marks : 0

3 ମୋଲ୍ ସ୍ଵାତନ୍ତ୍ର କମ୍ପ୍ଲେକ୍ସ $\text{Co(en)}_2\text{Cl}_3$ ସୂତ୍ର ସହିତ ଅତ୍ୟଧିକ ସିଲଭର ନାଇଟ୍ରେଟ୍ ସହିତ ପ୍ରତିକ୍ରିୟା କରି 3 ମୋଲ୍ ସିଲଭର କ୍ଲୋରାଇଡ୍ ଦେଇଥାଏ । Co ର ଦ୍ଵିତୀୟକ ଯୋଜ୍ୟତା କମ୍ପ୍ଲେକ୍ସରେ ହେଉଛି _____ ।

(ନିକଟତମ ପୂର୍ଣ୍ଣସଂଖ୍ୟାରେ ପରିଣତ କର)

Response Type : Numeric

Evaluation Required For SA : Yes

Show Word Count : Yes

Answers Type : Equal

Text Areas : PlainText

Possible Answers :

1

Question Type : SA

Correct Marks : 4 Wrong Marks : 0

The dihedral angle in staggered form of Newman projection of 1,1,1-Trichloro ethane is _____ degree. (Round off to the Nearest Integer).

Response Type : Numeric

Evaluation Required For SA : Yes

Show Word Count : Yes

Answers Type : Equal

Text Areas : PlainText

Possible Answers :

1

Question Type : SA

Correct Marks : 4 Wrong Marks : 0

1,1,1- ଟ୍ରାଇକ୍ଲୋରୋଇଥେନ୍‌ର ନିଉମାନ ପ୍ରୋଜେକ୍ଟନ୍‌ରେ ଷ୍ଟାଗାରତ୍ ପ୍ରକାରରେ ଡାଇହେଡ୍ରାଲ୍ କୋଣଟି ହେଉଛି _____
ଡିଗ୍ରୀ।

(ନିକଟତମ ପୂର୍ଣ୍ଣସଂଖ୍ୟାରେ ପରିଣତ କର)

Response Type : Numeric

Evaluation Required For SA : Yes

Show Word Count : Yes

Answers Type : Equal

Text Areas : PlainText

Possible Answers :

1

Question Type : SA

Correct Marks : 4 Wrong Marks : 0

10.0 mL of 0.05 M KMnO_4 solution was consumed in a titration with 10.0 mL of given oxalic acid dihydrate solution. The strength of given oxalic acid solution is _____ $\times 10^{-2}$ g/L.
(Round off to the Nearest Integer).

Response Type : Numeric

Evaluation Required For SA : Yes

Show Word Count : Yes

Answers Type : Equal

Text Areas : PlainText

Possible Answers :

1

Question Type : SA

Correct Marks : 4 Wrong Marks : 0

10.0 mL of 0.05 M KMnO_4 ଦ୍ରବଣ ଦିଆଯାଇଥିବା 10.0 mL ଅକ୍ଜାଲିକ୍ ଅମ୍ଳ ଡାଇହାଇଡ୍ରେଟ୍ ଦ୍ରବଣର ଅନୁମାପନରେ ଖର୍ଚ୍ଚ ହେଲା । ଦତ୍ତ ଅକ୍ଜାଲିକ୍ ଅମ୍ଳ ଦ୍ରବଣର ଶକ୍ତି ହେଉଛି _____ $\times 10^{-2}$ g/L ।

(ନିକଟତମ ପୂର୍ଣ୍ଣସଂଖ୍ୟାରେ ପରିଣତ କର)

Response Type : Numeric

Evaluation Required For SA : Yes

Show Word Count : Yes

Answers Type : Equal

Text Areas : PlainText

Possible Answers :

1

Mathematics Section A

Section Id :	864351852
Section Number :	5
Section type :	Online
Mandatory or Optional :	Mandatory
Number of Questions :	20
Number of Questions to be attempted :	20
Section Marks :	80
Enable Mark as Answered Mark for Review and Clear Response :	Yes
Sub-Section Number :	1
Sub-Section Id :	8643511079
Question Shuffling Allowed :	Yes

Question Type : MCQ **Is Question Mandatory :** No

Correct Marks : 4 **Wrong Marks :** 1

Let $f: \mathbf{R} \rightarrow \mathbf{R}$ be defined as

$f(x+y) + f(x-y) = 2f(x)f(y)$, $f\left(\frac{1}{2}\right) = -1$. Then, the value of

$\sum_{k=1}^{20} \frac{1}{\sin(k)\sin(k+f(k))}$ is equal to :

Options :

1. $\sec^2(1) \sec(21) \cos(20)$
2. $\operatorname{cosec}^2(21) \cos(20) \cos(2)$
3. $\operatorname{cosec}^2(1) \operatorname{cosec}(21) \sin(20)$
4. $\sec^2(21) \sin(20) \sin(2)$

Question Type : MCQ Is Question Mandatory : No

Correct Marks : 4 Wrong Marks : 1

ମାନିନିଅ ଫଳନ $f: \mathbf{R} \rightarrow \mathbf{R}$ କୁ ଏହିପରି $f(x+y) + f(x-y) = 2f(x)f(y)$, $f\left(\frac{1}{2}\right) = -1$ ପ୍ରକାଶ କରାଯାଇଅଛି, ତେବେ

$\sum_{k=1}^{20} \frac{1}{\sin(k)\sin(k+f(k))}$ ସମାନ :

Options :

1. $\sec^2(1) \sec(21) \cos(20)$
2. $\operatorname{cosec}^2(21) \cos(20) \cos(2)$

3. $\operatorname{cosec}^2(1) \operatorname{cosec}(21) \sin(20)$

4. $\sec^2(21) \sin(20) \sin(2)$

Question Type : MCQ Is Question Mandatory : No

Correct Marks : 4 Wrong Marks : 1

Let the mean and variance of the frequency distribution

$$x: \quad x_1=2 \quad x_2=6 \quad x_3=8 \quad x_4=9$$

$$f: \quad 4 \quad 4 \quad \alpha \quad \beta$$

be 6 and 6.8 respectively. If x_3 is changed from 8 to 7, then the mean for the new data will be :

Options :

1. $\frac{17}{3}$

2. 5

3. $\frac{16}{3}$

4. 4

Question Type : MCQ Is Question Mandatory : No

Correct Marks : 4 Wrong Marks : 1

ମନେକର (ମାନିନିଅ) ବାରମ୍ବାରତା ବଣ୍ଟନ

$$x: x_1=2 \quad x_2=6 \quad x_3=8 \quad x_4=9$$

$$f: 4 \quad 4 \quad \alpha \quad \beta$$

ରେ ମଧ୍ୟମାନ (ମଧ୍ୟକ) ଏବଂ ପ୍ରସରଣ (ଭାରିଆନସ) ଯଥାକ୍ରମେ 6 ଏବଂ 6.8 । ଯଦି x_3 ର ମୂଲ୍ୟ 8 ରୁ ପରିବର୍ତ୍ତିତ ହୋଇ 7 ହୁଏ, ତେବେ ନୂତନ ତଥ୍ୟାବଳୀ ପାଇଁ ମଧ୍ୟମାନ (ମଧ୍ୟକ) ହେବ :

Options :

1. $\frac{17}{3}$

2. 5

3. $\frac{16}{3}$

4. 4

Question Type : MCQ Is Question Mandatory : No

Correct Marks : 4 Wrong Marks : 1

Consider a circle C which touches the y -axis at $(0, 6)$ and cuts off an intercept $6\sqrt{5}$ on the x -axis. Then the radius of the circle C is equal to :

Options :

1. 8

2. $\sqrt{53}$

3. 9

4.

$$\sqrt{82}$$

Question Type : MCQ Is Question Mandatory : No

Correct Marks : 4 Wrong Marks : 1

ଏକ ବୃତ୍ତ C କୁ ବିଚାର କର ଯାହା y -ଅକ୍ଷକୁ ବିନ୍ଦୁ $(0, 6)$ ଠାରେ ସ୍ପର୍ଶ କରେ ଏବଂ x -ଅକ୍ଷରେ $6\sqrt{5}$ ଛେଦାଂଶ ସୃଷ୍ଟି କରେ ।

ତେବେ ବୃତ୍ତ C ର ବ୍ୟାସାର୍ଦ୍ଧ ସମାନ :

Options :

1. 8

2. $\sqrt{53}$

3. 9

4. $\sqrt{82}$

Question Type : MCQ Is Question Mandatory : No

Correct Marks : 4 Wrong Marks : 1

Two sides of a parallelogram are along the lines $4x + 5y = 0$ and $7x + 2y = 0$. If the equation of one of the diagonals of the parallelogram is $11x + 7y = 9$, then other diagonal passes through the point :

Options :

1. $(1, 2)$

2. $(2, 2)$

3. $(2, 1)$

4. (1, 3)

Question Type : MCQ Is Question Mandatory : No

Correct Marks : 4 Wrong Marks : 1

ଗୋଟିଏ ସମାନ୍ତରିକ କ୍ଷେତ୍ରର ପରସ୍ପର ପାଖାପାଖି ବାହୁଗୁଡ଼ିକର ସମୀକରଣ $4x+5y=0$ ଏବଂ $7x+2y=0$ ଅଟେ । ଯଦି ସାମାନ୍ତରିକ କ୍ଷେତ୍ରର ଗୋଟିଏ କର୍ଣ୍ଣର ସମୀକରଣ $11x+7y=9$ ହୁଏ, ତେବେ ଅନ୍ୟ କର୍ଣ୍ଣଟି ଯେଉଁ ବିନ୍ଦୁ ମଧ୍ୟଦେଇ ଗତିକରେ ସେ ବିନ୍ଦୁଟି :

Options :

1. (1, 2)

2. (2, 2)

3. (2, 1)

4. (1, 3)

Question Type : MCQ Is Question Mandatory : No

Correct Marks : 4 Wrong Marks : 1

Let $f : [0, \infty) \rightarrow [0, 3]$ be a function defined by

$$f(x) = \begin{cases} \max \{\sin t : 0 \leq t \leq x\}, & 0 \leq x \leq \pi \\ 2 + \cos x, & x > \pi \end{cases}$$

Then which of the following is true ?

Options :

1. f is not continuous exactly at two points in $(0, \infty)$

2. f is continuous everywhere but not differentiable exactly at two points in $(0, \infty)$
3. f is continuous everywhere but not differentiable exactly at one point in $(0, \infty)$
4. f is differentiable everywhere in $(0, \infty)$

Question Type : MCQ Is Question Mandatory : No

Correct Marks : 4 Wrong Marks : 1

ମାନିନିଅ ଫଳନ $f: [0, \infty) \rightarrow [0, 3]$ କୁ $f(x) = \begin{cases} \max \{ \sin t : 0 \leq t \leq x \}, & 0 \leq x \leq \pi \\ 2 + \cos x, & x > \pi \end{cases}$ ରୂପେ ବର୍ଣ୍ଣନା

କରାଯାଇଅଛି ।

ତେବେ ନିମ୍ନ ମଧ୍ୟରୁ କେଉଁଟି ସତ ଅଟେ ?

Options :

1. $(0, \infty)$ ଅନ୍ତରାଳରେ ଠିକ୍ ଦୁଇଟି ବିନ୍ଦୁରେ f ବିଚ୍ଛିନ୍ନ ।
2. $(0, \infty)$ ଅନ୍ତରାଳରେ ଠିକ୍ ଦୁଇଟି ବିନ୍ଦୁରେ f ଅବକଳନୀୟ ନୁହେଁ କିନ୍ତୁ f ସର୍ବତ୍ର ଅବିଚ୍ଛିନ୍ନ ।
3. $(0, \infty)$ ଅନ୍ତରାଳରେ ଠିକ୍ ଗୋଟିଏ ବିନ୍ଦୁରେ f ଅବକଳନୀୟ ନୁହେଁ କିନ୍ତୁ f ସର୍ବତ୍ର ଅବିଚ୍ଛିନ୍ନ ।
4. $(0, \infty)$ ଅନ୍ତରାଳରେ f ସର୍ବତ୍ର ଅବକଳନୀୟ ।

Question Type : MCQ Is Question Mandatory : No

Correct Marks : 4 Wrong Marks : 1

Which of the following is the negation of the statement "for all $M > 0$, there exists $x \in S$ such that $x \geq M$ " ?

Options :

1. there exists $M > 0$, there exists $x \in S$ such that $x < M$
2. there exists $M > 0$, there exists $x \in S$ such that $x \geq M$
3. there exists $M > 0$, such that $x < M$ for all $x \in S$
4. there exists $M > 0$, such that $x \geq M$ for all $x \in S$

Question Type : MCQ Is Question Mandatory : No

Correct Marks : 4 Wrong Marks : 1

ନିମ୍ନମଧ୍ୟରୁ କେଉଁ ଉକ୍ତି (କଥନ)ଟି ଏହି କଥନ "ସମସ୍ତ $M > 0$ ପାଇଁ, ଗୋଟିଏ $x \in S$ ଅଛି ଯେପରିକି $x \geq M$ " ର, ସର୍ବୋତ୍ତମ ନାସ୍ତିବାଚକ କଥନ (ଉକ୍ତି) ଅଟେ ?

Options :

1. ଏକ $M > 0$ ଅଛି, ଏକ $x \in S$ ଅଛି ଯେପରିକି $x < M$ ।
2. ଏକ $M > 0$ ଅଛି, ଏକ $x \in S$ ଅଛି ଯେପରିକି $x \geq M$ ।
3. ଏକ $M > 0$ ଅଛି, ଯେପରିକି ସମସ୍ତ $x \in S$ ପାଇଁ $x < M$ ।
4. ଏକ $M > 0$ ଅଛି, ଯେପରିକି ସମସ୍ତ $x \in S$ ପାଇଁ $x \geq M$ ।

Question Type : MCQ Is Question Mandatory : No

Correct Marks : 4 Wrong Marks : 1

The area of the region bounded by $y - x = 2$ and $x^2 = y$ is equal to :

Options :

1. $\frac{2}{3}$

2. $\frac{4}{3}$

3. $\frac{9}{2}$

4. $\frac{16}{3}$

Question Type : MCQ Is Question Mandatory : No

Correct Marks : 4 Wrong Marks : 1

$y - x = 2$ ଏବଂ $x^2 = y$ ଦ୍ୱାରା ଆବଦ୍ଧ କ୍ଷେତ୍ରର କ୍ଷେତ୍ରଫଳ ସମାନ :

Options :

1. $\frac{2}{3}$

2. $\frac{4}{3}$

3. $\frac{9}{2}$

4.

$\frac{16}{3}$

Question Type : MCQ Is Question Mandatory : No

Correct Marks : 4 Wrong Marks : 1

Let $y=y(x)$ be the solution of the differential equation $(x-x^3)dy=(y+yx^2-3x^4)dx$, $x > 2$.

If $y(3)=3$, then $y(4)$ is equal to :

Options :

1. 12

2. 8

3. 16

4. 4

Question Type : MCQ Is Question Mandatory : No

Correct Marks : 4 Wrong Marks : 1

ଧରାଯାଉ ଅବକଳ ସମୀକରଣ $(x-x^3)dy=(y+yx^2-3x^4)dx$, $x > 2$ ର $y=y(x)$ ସମାଧାନ । ଯଦି $y(3)=3$,

ତେବେ $y(4)$ ସମାନ :

Options :

1. 12

2. 8

3. 16

4. 4

Question Type : MCQ Is Question Mandatory : No

Correct Marks : 4 Wrong Marks : 1

The point P (a, b) undergoes the following three transformations successively :

- (a) reflection about the line $y=x$.
- (b) translation through 2 units along the positive direction of x -axis.
- (c) rotation through angle $\frac{\pi}{4}$ about the origin in the anti-clockwise direction.

If the co-ordinates of the final position of the point P are $\left(-\frac{1}{\sqrt{2}}, \frac{7}{\sqrt{2}}\right)$, then the value of

$2a+b$ is equal to :

Options :

1. 5

2. 7

3. 9

4. 13

Question Type : MCQ Is Question Mandatory : No

Correct Marks : 4 Wrong Marks : 1

ବିନ୍ଦୁ P (a, b) ନିମ୍ନ ତିନିଗୋଟି ପରିବର୍ତ୍ତନ, ଗୋଟିଏ ପରେ ଗୋଟିଏ ମଧ୍ୟ ଦେଇ ଗଠିକରେ ।

(a) $y=x$ ରେଖା ମଧ୍ୟ ଦେଇ ପ୍ରତିଫଳନ ।

(b) x -ଅକ୍ଷର ଧନାତ୍ମକ ଦିଗରେ 2 ଏକକ ସ୍ଥାନାନ୍ତର ।

(c) ମୂଳବିନ୍ଦୁଠାରେ ଘଣ୍ଟାର ବିପରୀତ ଦିଗରେ $\frac{\pi}{4}$ କୋଣରେ ଘୂର୍ଣ୍ଣନ ।

ଏହାପରେ ଯଦି ଶେଷ ବିନ୍ଦୁ P ର ସ୍ଥାନାଙ୍କ $\left(-\frac{1}{\sqrt{2}}, \frac{7}{\sqrt{2}}\right)$ ହୁଏ, ତେବେ $2a+b$ ର ମୂଲ୍ୟ ସମାନ :

Options :

- 5
- 7
- 9
- 13

Question Type : MCQ Is Question Mandatory : No

Correct Marks : 4 Wrong Marks : 1

A possible value of 'x', for which the ninth term in the expansion of

$$\left\{3^{\log_3 \sqrt{25^{x-1} + 7}} + 3^{\left(-\frac{1}{8}\right) \log_3(5^{x-1}+1)}\right\}^{10} \text{ in the increasing powers of } 3^{\left(-\frac{1}{8}\right) \log_3(5^{x-1}+1)}$$

is equal to 180, is :

Options :

- 0

2. 1

3. -1

4. 2

Question Type : MCQ Is Question Mandatory : No

Correct Marks : 4 Wrong Marks : 1

'x' ର ଏକ ସମ୍ଭବ ମୂଲ୍ୟ ଯାହାପାଇଁ $\left\{ 3^{\log_3 \sqrt{25^x - 1} + 7} + 3^{\left(-\frac{1}{8}\right) \log_3 (5^{x-1} + 1)} \right\}^{10}$ ର ପ୍ରସାରଣରେ ନବମ ପଦଟି

ପ୍ରସାରିତ କ୍ଷମତା $3^{\left(-\frac{1}{8}\right) \log_3 (5^{x-1} + 1)}$ ର 180 ସହ ସମାନ, ତେବେ x ଅଟେ :

Options :

1. 0

2. 1

3. -1

4. 2

Question Type : MCQ Is Question Mandatory : No

Correct Marks : 4 Wrong Marks : 1

Let \mathbb{C} be the set of all complex numbers. Let

$$S_1 = \{z \in \mathbb{C} : |z-2| \leq 1\} \text{ and}$$

$$S_2 = \{z \in \mathbb{C} : z(1+i) + \bar{z}(1-i) \geq 4\}.$$

Then, the maximum value of $\left|z - \frac{5}{2}\right|^2$ for $z \in S_1 \cap S_2$ is equal to :

Options :

1. $\frac{3 + 2\sqrt{2}}{4}$

2. $\frac{3 + 2\sqrt{2}}{2}$

3. $\frac{5 + 2\sqrt{2}}{2}$

4. $\frac{5 + 2\sqrt{2}}{4}$

Question Type : MCQ Is Question Mandatory : No

Correct Marks : 4 Wrong Marks : 1

ମାନିନିଅ \mathbb{C} ସମସ୍ତ ସମ୍ପୂର୍ଣ୍ଣ (କମ୍ପ୍ଲେକ୍ସ) ସଂଖ୍ୟା ମାନଙ୍କର ଏକ ସେଟ୍ ।

ଯଦି $S_1 = \{z \in \mathbb{C} : |z-2| \leq 1\}$ ଏବଂ

$S_2 = \{z \in \mathbb{C} : z(1+i) + \bar{z}(1-i) \geq 4\}$ ହୁଏ, ତେବେ

$z \in S_1 \cap S_2$ ପାଇଁ $\left|z - \frac{5}{2}\right|^2$ ର ସର୍ବାଧିକ ମୂଲ୍ୟ ସମାନ :

Options :

1. $\frac{3 + 2\sqrt{2}}{4}$

2. $\frac{3 + 2\sqrt{2}}{2}$

3. $\frac{5 + 2\sqrt{2}}{2}$

4. $\frac{5 + 2\sqrt{2}}{4}$

Question Type : MCQ Is Question Mandatory : No

Correct Marks : 4 Wrong Marks : 1

Let $f: (a, b) \rightarrow \mathbb{R}$ be twice differentiable function such that $f(x) = \int_a^x g(t)dt$ for a differentiable function $g(x)$. If $f(x)=0$ has exactly five distinct roots in (a, b) , then $g(x)g'(x)=0$ has at least :

Options :

1. three roots in (a, b)

2. five roots in (a, b)

3. seven roots in (a, b)

4. twelve roots in (a, b)

Question Type : MCQ Is Question Mandatory : No

Correct Marks : 4 Wrong Marks : 1

ମାନିନିଅ $f: (a, b) \rightarrow \mathbf{R}$ ଏକ ଦୁଇଥର ଅବକଳନୀୟ ଫଳନ ଯେପରିକି $f(x) = \int_a^x g(t)dt$, (ଏକ ଅବକଳନୀୟ ଫଳନ $g(x)$ ପାଇଁ) । ଯଦି ଫଳନ f ର, (a, b) ମଧ୍ୟରେ ଠିକ୍ ପାଞ୍ଚଗୋଟି ପୃଥକ୍ ବୀଜ (ମୂଳ) ଅଛି, ତେବେ ଫଳନ $g(x)g'(x)=0$ ର ରହିବ ଅତିକମ୍ରେ :

Options :

1. ତିନିଗୋଟି ବୀଜ (a, b) ମଧ୍ୟରେ ।
2. ପାଞ୍ଚଗୋଟି ବୀଜ (a, b) ମଧ୍ୟରେ ।
3. ସାତଗୋଟି ବୀଜ (a, b) ମଧ୍ୟରେ ।
4. ବାରଗୋଟି ବୀଜ (a, b) ମଧ୍ୟରେ ।

Question Type : MCQ Is Question Mandatory : No

Correct Marks : 4 Wrong Marks : 1

Let A and B be two 3×3 real matrices such that $(A^2 - B^2)$ is invertible matrix. If $A^5 = B^5$ and $A^3B^2 = A^2B^3$, then the value of the determinant of the matrix $A^3 + B^3$ is equal to :

Options :

1. 0
2. 1
3. 2
4. 4

Question Type : MCQ Is Question Mandatory : No

Correct Marks : 4 Wrong Marks : 1

ମାନିନିଆ A ଏବଂ B ଦୁଇଗୋଟି 3×3 ବାସ୍ତବ ମାଟ୍ରିକ୍ସ (ସାରଣୀ) ଯେପରିକି $(A^2 - B^2)$ ମାଟ୍ରିକ୍ସର ଇନ୍ଭରସ୍ ବାହାରି ପାରିବ । ଯଦି $A^5 = B^5$ ଏବଂ $A^3 B^2 = A^2 B^3$, ତେବେ ମାଟ୍ରିକ୍ସ $A^3 + B^3$ ର ଡିଟରମିନାଣ୍ଟର ମୂଲ୍ୟ ସମାନ :

Options :

1. 0

2. 1

3. 2

4. 4

Question Type : MCQ Is Question Mandatory : No

Correct Marks : 4 Wrong Marks : 1

Let N be the set of natural numbers and a relation R on N be defined by

$R = \{(x, y) \in N \times N : x^3 - 3x^2y - xy^2 + 3y^3 = 0\}$. Then the relation R is :

Options :

1. reflexive and symmetric, but not transitive

2. reflexive but neither symmetric nor transitive

3. symmetric but neither reflexive nor transitive

4. an equivalence relation

Question Type : MCQ Is Question Mandatory : No

Correct Marks : 4 Wrong Marks : 1

ମାନିନିଅ N ହେଉଛି ସ୍ଵାଭାବିକ ସଂଖ୍ୟାମାନଙ୍କର ସେଟ୍ ଏବଂ N ଉପରେ R ଏକ ସଂପର୍କ (ସମ୍ବନ୍ଧ) ଯାହାକୁ,
 $R = \{(x, y) \in N \times N : x^3 - 3x^2y - xy^2 + 3y^3 = 0\}$ ରୂପେ ବର୍ଣ୍ଣନା କରାଯାଇଅଛି । ତେବେ ସଂପର୍କ R ଅଟେ :

Options :

1. ସ୍ଵାଭିମୂଖୀ ଏବଂ ସମଞ୍ଜସ, କିନ୍ତୁ ସଂକ୍ରମୀ ନୁହେଁ ।
2. ସ୍ଵାଭିମୂଖୀ, କିନ୍ତୁ ସମଞ୍ଜସ ନୁହେଁ ବା ସଂକ୍ରମୀ ନୁହେଁ ।
3. ସମଞ୍ଜସ କିନ୍ତୁ ସ୍ଵାଭିମୂଖୀ ନୁହେଁ ବା ସଂକ୍ରମୀ ନୁହେଁ ।
4. ଏକ ସମତୁଲ୍ୟ ସମ୍ବନ୍ଧ (ସଂପର୍କ) ।

Question Type : MCQ Is Question Mandatory : No

Correct Marks : 4 Wrong Marks : 1

Let $\alpha = \max_{x \in \mathbb{R}} \{8^{2\sin 3x} \cdot 4^{4\cos 3x}\}$ and $\beta = \min_{x \in \mathbb{R}} \{8^{2\sin 3x} \cdot 4^{4\cos 3x}\}$.

If $8x^2 + bx + c = 0$ is a quadratic equation whose roots are $\alpha^{1/5}$ and $\beta^{1/5}$, then the value of $c - b$ is equal to :

Options :

1. 42
2. 43
3. 47
4. 50

Question Type : MCQ Is Question Mandatory : No

Correct Marks : 4 Wrong Marks : 1

ମାନିନିଅ $\alpha = \max_{x \in \mathbb{R}} \{8^{2\sin 3x} \cdot 4^{4\cos 3x}\}$ ଏବଂ $\beta = \min_{x \in \mathbb{R}} \{8^{2\sin 3x} \cdot 4^{4\cos 3x}\}$ । ଯଦି $8x^2 + bx + c = 0$ ଏକ

ଦ୍ଵିଘାତ ସମୀକରଣ ଅଟେ ଯାହାର ମୂଳ(ବାଜ) ମାନେ $\alpha^{1/5}$ ଏବଂ $\beta^{1/5}$ ହୁଅନ୍ତି, ତେବେ $c-b$ ର ମୂଲ୍ୟ ସମାନ :

Options :

1. 42

2. 43

3. 47

4. 50

Question Type : MCQ Is Question Mandatory : No

Correct Marks : 4 Wrong Marks : 1

The value of $\lim_{x \rightarrow 0} \left(\frac{x}{\sqrt[3]{1 - \sin x} - \sqrt[3]{1 + \sin x}} \right)$ is equal to :

Options :

1. 0

2. -1

3. -4

4. 4

Question Type : MCQ Is Question Mandatory : No

Correct Marks : 4 Wrong Marks : 1

$\lim_{x \rightarrow 0} \left(\frac{x}{\sqrt[8]{1 - \sin x} - \sqrt[8]{1 + \sin x}} \right)$ ର ମୂଲ୍ୟ ସମାନ :

Options :

1. 0
2. -1
3. -4
4. 4

Question Type : MCQ Is Question Mandatory : No

Correct Marks : 4 Wrong Marks : 1

A student appeared in an examination consisting of 8 true - false type questions. The student guesses the answers with equal probability. The smallest value of n, so that the probability of

guessing at least 'n' correct answers is less than $\frac{1}{2}$, is :

Options :

1. 3
2. 4
3. 5

4. 6

Question Type : MCQ Is Question Mandatory : No

Correct Marks : 4 Wrong Marks : 1

ଜଣେ ଛାତ୍ର 8 ଗୋଟି ସତ-ମିଛ ପ୍ରକାର ପ୍ରଶ୍ନରୁ ପରୀକ୍ଷା ଦେଲା । ଛାତ୍ରଟି ସମସ୍ତ ଉତ୍ତରଗୁଡ଼ିକୁ ସମାନ ସମ୍ଭାବ୍ୟତା ଥିବା

ଭାବିଲା । ଅତିକମରେ 'n' ଟି ଠିକ୍ ଉତ୍ତର ଭାବିବାର ସମ୍ଭାବ୍ୟତା $\frac{1}{2}$ ଠାରୁ ସାନ ହେଲେ, n ର ନ୍ୟୁନତମ ମୂଲ୍ୟ ଅଟେ :

Options :

1. 3

2. 4

3. 5

4. 6

Question Type : MCQ Is Question Mandatory : No

Correct Marks : 4 Wrong Marks : 1

For real numbers α and $\beta \neq 0$, if the point of intersection of the straight lines

$$\frac{x - \alpha}{1} = \frac{y - 1}{2} = \frac{z - 1}{3} \text{ and } \frac{x - 4}{\beta} = \frac{y - 6}{3} = \frac{z - 7}{3},$$

lies on the plane $x + 2y - z = 8$, then $\alpha - \beta$ is equal to :

Options :

1. 3

2. 5

3. 7

4. 9

Question Type : MCQ Is Question Mandatory : No

Correct Marks : 4 Wrong Marks : 1

ବାସ୍ତବ ସଂଖ୍ୟା $\alpha \neq 0$ ଏବଂ $\beta \neq 0$ ପାଇଁ, ଯଦି ଦୁଇଟି ସରଳରେଖ $\frac{x - \alpha}{1} = \frac{y - 1}{2} = \frac{z - 1}{3}$ ଏବଂ

$\frac{x - 4}{\beta} = \frac{y - 6}{3} = \frac{z - 7}{3}$ ର ଛେଦବିନ୍ଦୁ ସମତଳ $x + 2y - z = 8$ ଉପରେ ଅବସ୍ଥିତ ହୁଏ, ତେବେ $\alpha - \beta$ ସମାନ :

Options :

1. 3

2. 5

3. 7

4. 9

Question Type : MCQ Is Question Mandatory : No

Correct Marks : 4 Wrong Marks : 1

If $\tan\left(\frac{\pi}{9}\right)$, x , $\tan\left(\frac{7\pi}{18}\right)$ are in arithmetic progression and $\tan\left(\frac{\pi}{9}\right)$, y , $\tan\left(\frac{5\pi}{18}\right)$ are also in

arithmetic progression, then $|x - 2y|$ is equal to :

Options :

1. 0

2. 1

3. 3

4. 4

Question Type : MCQ Is Question Mandatory : No

Correct Marks : 4 Wrong Marks : 1

ଯଦି $\tan\left(\frac{\pi}{9}\right)$, x , $\tan\left(\frac{7\pi}{18}\right)$ ଏକ ସମାନ୍ତର ଶ୍ରେଣୀ (ପ୍ରଗତୀ)ରେ ରୁହନ୍ତି ଓ $\tan\left(\frac{\pi}{9}\right)$, y , $\tan\left(\frac{5\pi}{18}\right)$ ମଧ୍ୟ ଏକ

ସମାନ୍ତର ଶ୍ରେଣୀ (ପ୍ରଗତୀ)ରେ ରୁହନ୍ତି, ତେବେ $|x-2y|$ ସମାନ :

Options :

1. 0

2. 1

3. 3

4. 4

Question Type : MCQ Is Question Mandatory : No

Correct Marks : 4 Wrong Marks : 1

Let \vec{a} , \vec{b} and \vec{c} be three vectors such that $\vec{a} = \vec{b} \times (\vec{b} \times \vec{c})$. If magnitudes of the vectors

\vec{a} , \vec{b} and \vec{c} are $\sqrt{2}$, 1 and 2 respectively and the angle between \vec{b} and \vec{c} is θ $\left(0 < \theta < \frac{\pi}{2}\right)$,

then the value of $1 + \tan \theta$ is equal to :

Options :

1. 1

2. 2

3. $\sqrt{3} + 1$

4. $\frac{\sqrt{3} + 1}{\sqrt{3}}$

Question Type : MCQ Is Question Mandatory : No

Correct Marks : 4 Wrong Marks : 1

ମନେକର \vec{a} , \vec{b} ଏବଂ \vec{c} ତିନିଗୋଟି ଦିଶାଙ୍କ ଯେପରିକି $\vec{a} = \vec{b} \times (\vec{b} \times \vec{c})$ । ଯଦି ଦିଶାଙ୍କ \vec{a} , \vec{b} ଏବଂ \vec{c}

ମାନଙ୍କର ଦୈର୍ଘ୍ୟ ଯଥାକ୍ରମେ $\sqrt{2}$, 1 ଏବଂ 2 ହୁଏ ଏବଂ \vec{b} ଓ \vec{c} ର ମଧ୍ୟବର୍ତ୍ତୀ କୋଣ θ ($0 < \theta < \frac{\pi}{2}$) ହୁଏ, ତେବେ

$1 + \tan \theta$ ର ମୂଲ୍ୟ ସମାନ :

Options :

1. 1

2. 2

3. $\sqrt{3} + 1$

4. $\frac{\sqrt{3} + 1}{\sqrt{3}}$

Mathematics Section B

Section Id :	864351853
Section Number :	6
Section type :	Online
Mandatory or Optional :	Mandatory
Number of Questions :	10
Number of Questions to be attempted :	5
Section Marks :	20
Enable Mark as Answered Mark for Review and Clear Response :	Yes
Sub-Section Number :	1
Sub-Section Id :	8643511080
Question Shuffling Allowed :	Yes

Question Type : SA

Correct Marks : 4 Wrong Marks : 0

If the real part of the complex number $z = \frac{3 + 2i \cos \theta}{1 - 3i \cos \theta}$, $\theta \in \left(0, \frac{\pi}{2}\right)$ is zero, then the value of

$\sin^2 3\theta + \cos^2 \theta$ is equal to _____.

Response Type : Numeric

Evaluation Required For SA : Yes

Show Word Count : Yes

Answers Type : Equal

Text Areas : PlainText

Possible Answers :

1

Question Type : SA

Correct Marks : 4 Wrong Marks : 0

$\theta \in \left(0, \frac{\pi}{2}\right)$ ପାଇଁ ଯଦି ସମ୍ପୂର୍ଣ୍ଣ (କମ୍ପ୍ଲେକ୍ସ) ସଂଖ୍ୟା $z = \frac{3 + 2i \cos\theta}{1 - 3i \cos\theta}$ ର ବାସ୍ତବ ଅଂଶ ଶୂନ୍ୟ ହୁଏ, ତେବେ $\sin^2 3\theta + \cos^2 \theta$

ର ମୂଲ୍ୟ ସମାନ _____ ।

Response Type : Numeric

Evaluation Required For SA : Yes

Show Word Count : Yes

Answers Type : Equal

Text Areas : PlainText

Possible Answers :

1

Question Type : SA

Correct Marks : 4 Wrong Marks : 0

If $A = \begin{bmatrix} 1 & 1 & 1 \\ 0 & 1 & 1 \\ 0 & 0 & 1 \end{bmatrix}$ and $M = A + A^2 + A^3 + \dots + A^{20}$, then the sum of all the elements of the

matrix M is equal to _____.

Response Type : Numeric

Evaluation Required For SA : Yes

Show Word Count : Yes

Answers Type : Equal

Text Areas : PlainText

Possible Answers :

1

Question Type : SA

Correct Marks : 4 Wrong Marks : 0

ଯଦି $A = \begin{bmatrix} 1 & 1 & 1 \\ 0 & 1 & 1 \\ 0 & 0 & 1 \end{bmatrix}$ ଏବଂ $M = A + A^2 + A^3 + \dots + A^{20}$, ତେବେ ମାଟ୍ରିକ୍ସ M ର ସମସ୍ତ ଉପାଦାନମାନଙ୍କର

ସମଷ୍ଟି ସମାନ _____ ।

Response Type : Numeric

Evaluation Required For SA : Yes

Show Word Count : Yes

Answers Type : Equal

Text Areas : PlainText

Possible Answers :

1

Question Type : SA

Correct Marks : 4 Wrong Marks : 0

Let n be a non-negative integer. Then the number of divisors of the form " $4n+1$ " of the number $(10)^{10} \cdot (11)^{11} \cdot (13)^{13}$ is equal to _____.

Response Type : Numeric

Evaluation Required For SA : Yes

Show Word Count : Yes

Answers Type : Equal

Text Areas : PlainText

Possible Answers :

1

Question Type : SA

Correct Marks : 4 Wrong Marks : 0

ମନେକର n ଏକ ଅଣ-ରାମ୍ଭକ ପୂର୍ଣ୍ଣସଂଖ୍ୟା । ତେବେ ସଂଖ୍ୟା $(10)^{10} \cdot (11)^{11} \cdot (13)^{13}$ ର " $4n+1$ " ଆକାରର ଭାଜକ ସଂଖ୍ୟା ସମାନ _____ ।

Response Type : Numeric

Evaluation Required For SA : Yes

Show Word Count : Yes

Answers Type : Equal

Text Areas : PlainText

Possible Answers :

1

Question Type : SA

Correct Marks : 4 Wrong Marks : 0

The distance of the point $P(3, 4, 4)$ from the point of intersection of the line joining the points $Q(3, -4, -5)$ and $R(2, -3, 1)$ and the plane $2x + y + z = 7$, is equal to _____.

Response Type : Numeric

Evaluation Required For SA : Yes

Show Word Count : Yes

Answers Type : Equal

Text Areas : PlainText

Possible Answers :

1

Question Type : SA

Correct Marks : 4 Wrong Marks : 0

ବିନ୍ଦୁ $Q(3, -4, -5)$ ଏବଂ ବିନ୍ଦୁ $R(2, -3, 1)$ କୁ ଯୋଗ କରୁଥିବା ରେଖା ଏବଂ ସମତଳ $2x + y + z = 7$ ର ଛେଦବିନ୍ଦୁ ଠାରୁ ବିନ୍ଦୁ $P(3, 4, 4)$ ମଧ୍ୟରେ ଦୂରତା ସମାନ _____ ।

Response Type : Numeric

Evaluation Required For SA : Yes

Show Word Count : Yes

Answers Type : Equal

Text Areas : PlainText

Possible Answers :

1

Question Type : SA

Correct Marks : 4 Wrong Marks : 0

Let $y=y(x)$ be the solution of the differential equation $dy=e^{\alpha x+y}dx$; $\alpha \in \mathbf{N}$.

If $y(\log_e 2)=\log_e 2$ and $y(0)=\log_e\left(\frac{1}{2}\right)$, then the value of α is equal to _____.

Response Type : Numeric

Evaluation Required For SA : Yes

Show Word Count : Yes

Answers Type : Equal

Text Areas : PlainText

Possible Answers :

1

Question Type : SA

Correct Marks : 4 Wrong Marks : 0

ମାନିନିଅ ଅବକଳ ସମୀକରଣ $dy=e^{\alpha x+y}dx$; ($x, \alpha \in \mathbf{N}$ ଏବଂ $\alpha \neq 0$) ର $y=y(x)$ ସମାଧାନ ଅଟେ । ଯଦି

$y(\log_e 2)=\log_e 2$ ଏବଂ $y(0)=\log_e\left(\frac{1}{2}\right)$, ତେବେ α ର ମୂଲ୍ୟ ସମାନ _____ ।

Response Type : Numeric

Evaluation Required For SA : Yes

Show Word Count : Yes

Answers Type : Equal

Text Areas : PlainText

Possible Answers :

1

Question Type : SA

Correct Marks : 4 Wrong Marks : 0

If $\int_0^\pi (\sin^3 x) e^{-\sin^2 x} dx = \alpha - \frac{\beta}{e} \int_0^1 \sqrt{t} e^t dt$, then $\alpha + \beta$ is equal to _____.

Response Type : Numeric

Evaluation Required For SA : Yes

Show Word Count : Yes

Answers Type : Equal

Text Areas : PlainText

Possible Answers :

1

Question Type : SA

Correct Marks : 4 Wrong Marks : 0

ଯଦି $\int_0^\pi (\sin^3 x) e^{-\sin^2 x} dx = \alpha - \frac{\beta}{e} \int_0^1 \sqrt{t} e^t dt$, ତେବେ $\alpha + \beta$ ସମାନ _____ ।

Response Type : Numeric

Evaluation Required For SA : Yes

Show Word Count : Yes

Answers Type : Equal

Text Areas : PlainText

Possible Answers :

1

Question Type : SA

Correct Marks : 4 Wrong Marks : 0

Let $\vec{a} = \hat{i} - \alpha \hat{j} + \beta \hat{k}$, $\vec{b} = 3\hat{i} + \beta \hat{j} - \alpha \hat{k}$ and $\vec{c} = -\alpha \hat{i} - 2\hat{j} + \hat{k}$, where α and β are

integers. If $\vec{a} \cdot \vec{b} = -1$ and $\vec{b} \cdot \vec{c} = 10$, then $(\vec{a} \times \vec{b}) \cdot \vec{c}$ is equal to _____.

Response Type : Numeric

Evaluation Required For SA : Yes

Show Word Count : Yes

Answers Type : Equal

Text Areas : PlainText

Possible Answers :

1

Question Type : SA

Correct Marks : 4 Wrong Marks : 0

ମାନିନିଅ $\vec{a} = \hat{i} - \alpha\hat{j} + \beta\hat{k}$, $\vec{b} = 3\hat{i} + \beta\hat{j} - \alpha\hat{k}$ ଏବଂ $\vec{c} = -\alpha\hat{i} - 2\hat{j} + \hat{k}$, ଯେଉଁଠି α ଏବଂ β

ପୂର୍ଣ୍ଣସଂଖ୍ୟା । ଯଦି $\vec{a} \cdot \vec{b} = -1$ ଏବଂ $\vec{b} \cdot \vec{c} = 10$, ତେବେ $(\vec{a} \times \vec{b}) \cdot \vec{c}$ ସମାନ _____ ।

Response Type : Numeric

Evaluation Required For SA : Yes

Show Word Count : Yes

Answers Type : Equal

Text Areas : PlainText

Possible Answers :

1

Question Type : SA

Correct Marks : 4 Wrong Marks : 0

Let E be an ellipse whose axes are parallel to the co-ordinates axes, having its center at $(3, -4)$, one focus at $(4, -4)$ and one vertex at $(5, -4)$. If $mx - y = 4$, $m > 0$ is a tangent to the ellipse E, then the value of $5m^2$ is equal to _____.

Response Type : Numeric

Evaluation Required For SA : Yes

Show Word Count : Yes

Answers Type : Equal

Text Areas : PlainText

Possible Answers :

1

Question Type : SA

Correct Marks : 4 Wrong Marks : 0

ମନେକର E ଏକ ଦୀର୍ଘବୃତ୍ତ (ଇଲିପ୍ସ) ଯାହାର ଅକ୍ଷଗୁଡ଼ିକ କାର୍ତ୍ତକୀୟ ଅକ୍ଷମାନଙ୍କ ସହ ସମାନ୍ତର, କେନ୍ଦ୍ର $(3, -4)$ ବିନ୍ଦୁରେ, ନୀତି (ଫୋକସ) $(4, -4)$ ବିନ୍ଦୁରେ ଏବଂ ଏକ ଶୀର୍ଷବିନ୍ଦୁ $(5, -4)$ ବିନ୍ଦୁରେ ଅବସ୍ଥିତ । ଯଦି $mx - y = 4$, $m > 0$ ରେଖାଟି ଦୀର୍ଘବୃତ୍ତ (ଇଲିପ୍ସ) E ପ୍ରତି ସ୍ପର୍ଶକ ହୁଏ, ତେବେ $5m^2$ ର ମୂଲ୍ୟ ସମାନ _____ ।

Response Type : Numeric

Evaluation Required For SA : Yes

Show Word Count : Yes

Answers Type : Equal

Text Areas : PlainText

Possible Answers :

1

Question Type : SA

Correct Marks : 4 Wrong Marks : 0

Let $A = \{n \in \mathbb{N} \mid n^2 \leq n + 10,000\}$, $B = \{3k + 1 \mid k \in \mathbb{N}\}$ and $C = \{2k \mid k \in \mathbb{N}\}$, then the sum of all the elements of the set $A \cap (B - C)$ is equal to _____.

Response Type : Numeric

Evaluation Required For SA : Yes

Show Word Count : Yes

Answers Type : Equal

Text Areas : PlainText

Possible Answers :

1

Question Type : SA

Correct Marks : 4 Wrong Marks : 0

ମନେକର $A = \{n \in \mathbb{N} \mid n^2 \leq n + 10,000\}$, $B = \{3k + 1 \mid k \in \mathbb{N}\}$ ଏବଂ $C = \{2k \mid k \in \mathbb{N}\}$, ତେବେ ସେହି $A \cap (B - C)$ ର ସମସ୍ତ ଉପାଦାନ ମାନଙ୍କର ସମଷ୍ଟି ସମାନ _____ ।

Response Type : Numeric

Evaluation Required For SA : Yes

Show Word Count : Yes

Answers Type : Equal

Text Areas : PlainText

Possible Answers :

1

Question Type : SA

Correct Marks : 4 Wrong Marks : 0

The number of real roots of the equation $e^{4x} - e^{3x} - 4e^{2x} - e^x + 1 = 0$ is equal to _____.

Response Type : Numeric

Evaluation Required For SA : Yes

Show Word Count : Yes

Answers Type : Equal

Text Areas : PlainText

Possible Answers :

1

Question Type : SA

Correct Marks : 4 Wrong Marks : 0

ସମୀକରଣ $e^{4x} - e^{3x} - 4e^{2x} - e^x + 1 = 0$ ର ବାସ୍ତବ ମୂଳ (ବୀଜ) ସଂଖ୍ୟା ସମାନ _____ ।

Response Type : Numeric

Evaluation Required For SA : Yes

Show Word Count : Yes

Answers Type : Equal

Text Areas : PlainText

Possible Answers :

1